

## Data Sheet VSC7123

## 10-Bit Transceiver for Fibre Channel and Gigabit Ethernet

### Features

- 802.3z Gigabit Ethernet-Compliant 1.25 Gb/s Transceiver
- ANSI X3T11 Fibre Channel-Compliant 1.0625 Gb/s Transceiver
- 0.98 to 1.36 Gb/s Full-Duplex Operation
- 10-Bit TTL Interface for Transmit and Receive Data
- Automatic Lock-to-Reference
- RX Cable Equalization
- Analog/Digital Signal Detection
- JTAG Access Port for Testability
- Single +3.3V Supply, 650mW Typical
- Packages: 64-Pin 10mm and 14mm PQFP and 10mm TQFP

### General Description

The VSC7123 is a full-speed Fibre Channel and Gigabit Ethernet Transceiver with industry-standard pinouts. The VSC7123 accepts 10-bit 8B/10B encoded transmit data, latches it on the rising edge of REFCLK and serializes the data onto the TX PECL differential outputs at a baud rate which is 10 times the REFCLK frequency. Serial data input on the RX PECL differential inputs is resampled by the Clock Recovery Unit (CRU) and deserialized onto the 10-bit receive data bus synchronously to complementary divide-by-twenty clocks. The VSC7123 receiver detects “Comma” characters for frame alignment. An analog/digital signal detection circuit indicates that a valid signal is present on the RX input. A cable equalizer compensates for InterSymbol Interference (ISI) in order to increase maximum cable distances. The VSC7123 is a higher performance, lower cost replacement for the VSC7125 and VSC7135.

### VSC7123 Block Diagram

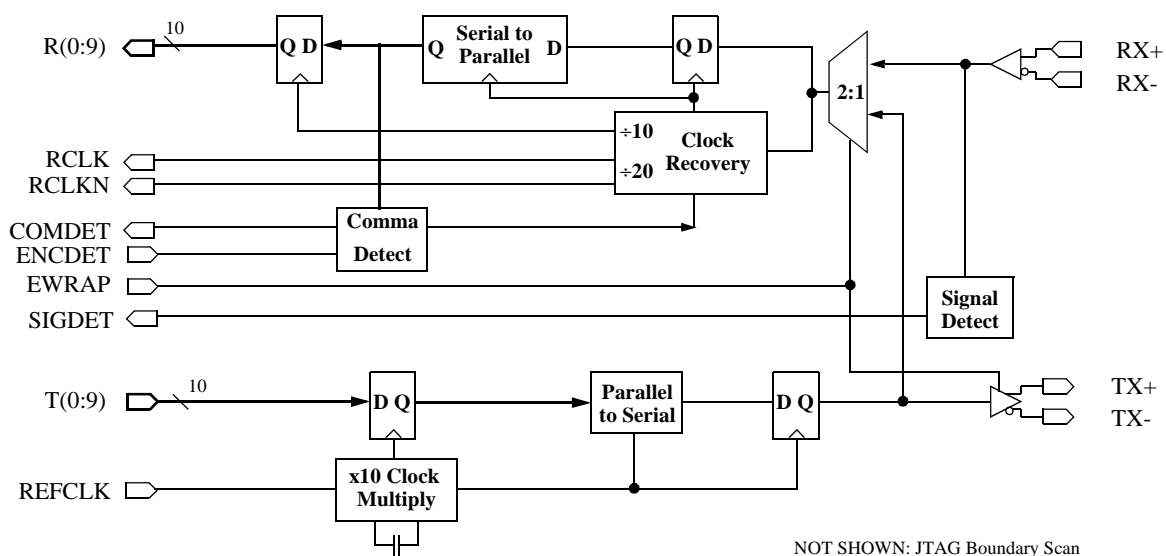

## Functional Description

### Clock Synthesizer

The VSC7123 clock synthesizer multiplies the reference frequency provided on the REFCLK pin by 10 to achieve a baud rate clock between 0.98GHz and 1.36GHz. The on-chip Phase Lock Loop (PLL) uses a single external 0.1 $\mu$ F capacitor to control the Loop Filter.

### Serializer

The VSC7123 accepts TTL input data as a parallel 10-bit character on the T(0:9) bus, which is latched into the input register on the rising edge of REFCLK. This data is serialized and transmitted on the TX PECL differential outputs at a baud rate that is 10 times the frequency of the REFCLK, with bit T0 transmitted first. User data should be encoded using 8B/10B block code or equivalent.

### Transmission Character Interface

An encoded byte is 10 bits and is referred to as a transmission character. The 10 bit interface on the VSC7123 corresponds to a transmission character. This mapping is illustrated in Figure 1.

**Figure 1: Transmission Order and Mapping of an 8B/10B Character**

Parallel Data Bits	T9	T8	T7	T6	T5	T4	T3	T2	T1	T0
8B/10B Bit Position	j	h	g	f	i	e	d	c	b	a
Comma Character	X	X	X	1	1	1	1	1	0	0



### Clock Recovery

The VSC7123 accepts differential high-speed serial inputs on the RX+/RX- pins, extracts the clock and retimes the data. Equalizers are included in the receiver to open the data eye and compensate for InterSymbol Interference which may be present in the incoming data. The serial bit stream should be encoded to provide DC balance and limited run length by an 8B/10B encoding scheme. The Clock Recovery Unit is completely monolithic and requires no external components. For proper operation, the baud rate of the data stream to be recovered should be within  $\pm 200$  ppm of 10 times the REFCLK frequency. For example, Gigabit Ethernet systems would use 125MHz oscillators with a  $\pm 100$ ppm accuracy resulting in  $\pm 200$  ppm between VSC7123 pairs.

### Deserializer

The recovered serial bit stream is converted into a 10-bit parallel output character. The VSC7123 provides complementary TTL recovered clocks, RCLK and RCLKN, which are 1/20<sup>th</sup> of the serial baud rate. The clocks are generated by dividing down the high-speed recovered clock, which is phase-locked to the serial data. The

**Data Sheet**  
**VSC7123***10-Bit Transceiver for Fibre  
Channel and Gigabit Ethernet*

serial data is retimed, deserialized and output on R(0:9). The parallel data will be captured by the adjoining protocol logic on the rising edges of RCLK and RCLKN.

If serial input data is not present or does not meet the required baud rate, the VSC7123 will continue to produce a recovered clock, allowing downstream logic functionality to continue. Under these circumstances, the RCLK/RCLKN output frequency differ from its expected frequency by no more than  $\pm 1\%$ .

**Word Alignment**

The VSC7123 provides 7-bit comma character recognition and data word alignment. Word synchronization is enabled by asserting ENCDDET HIGH. When synchronization is enabled, the receiver examines the recovered serial data for the presence of the "Comma" character. This pattern is "0011111XXX", where the leading zero corresponds to the first bit received. The comma sequence is not contained in any normal 8B/10B coded data character or pair of adjacent characters. It occurs only within special characters, known as K28.1, K28.5 and K28.7, which are defined for synchronization purposes. Improper alignment of the comma character is defined as any of the following conditions:

- 1) The comma is not aligned within the 10-bit transmission character such that R0...R6 = "0011111."
- 2) The comma straddles the boundary between two 10-bit transmission characters.
- 3) The comma is properly aligned but occurs in the received character presented during the rising edge of RCLK rather than RCLKN.

When ENCDDET is HIGH and an improperly aligned comma is encountered, the recovered clock is stretched (never slivered) so that the comma character and recovered clocks are properly aligned to R(0:9). This results in proper character and word alignment. When the parallel data alignment changes in response to a improperly aligned comma pattern, some data which would have been presented on the parallel output port may be lost. Additionally, the first Comma pattern may also be lost or corrupted. Subsequent data will be output correctly and properly aligned. When ENCDDET is LOW, the current alignment of the serial data is maintained indefinitely, regardless of data pattern.

When encountering a comma character, COMDET is driven HIGH. The COMDET pulse is presented simultaneously with the comma character and has a duration equal to the data, or half of an RCLK period. The COMDET signal is timed such that it can be captured by the adjoining protocol logic on the rising edge of RCLKN. Functional waveforms for synchronization are given in Figure 2 and Figure 3. Figure 2 shows the case when a comma character is detected and no phase adjustment is necessary. Figure 2 illustrates the position of the COMDET pulse in relation to the comma character on R(0:9). Figure 3 shows the case where the K28.5 is detected, but it is misaligned so a change in the output data alignment is required. Note that up to three characters prior to the comma character may be corrupted by the realignment process.

**Figure 2: Detection of a Properly Aligned Comma Character**

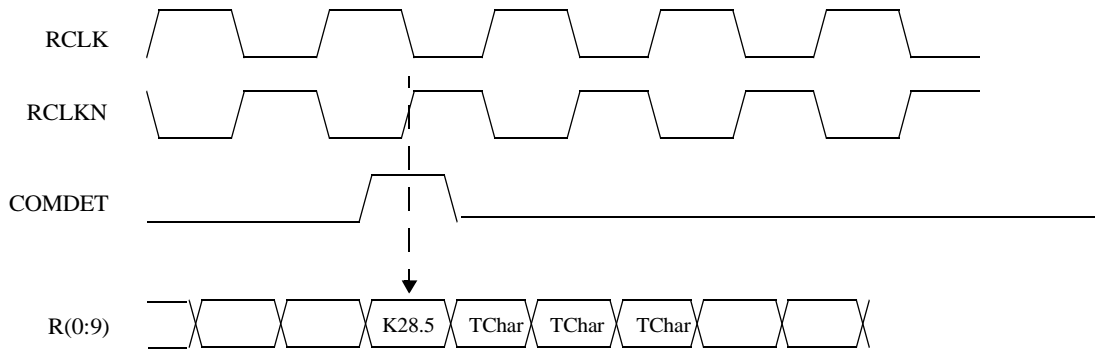

*TChar: 10-bit transmission character*

**Figure 3: Detection**

Receiving Two Consecutive K28.5+TChar Transmission Words

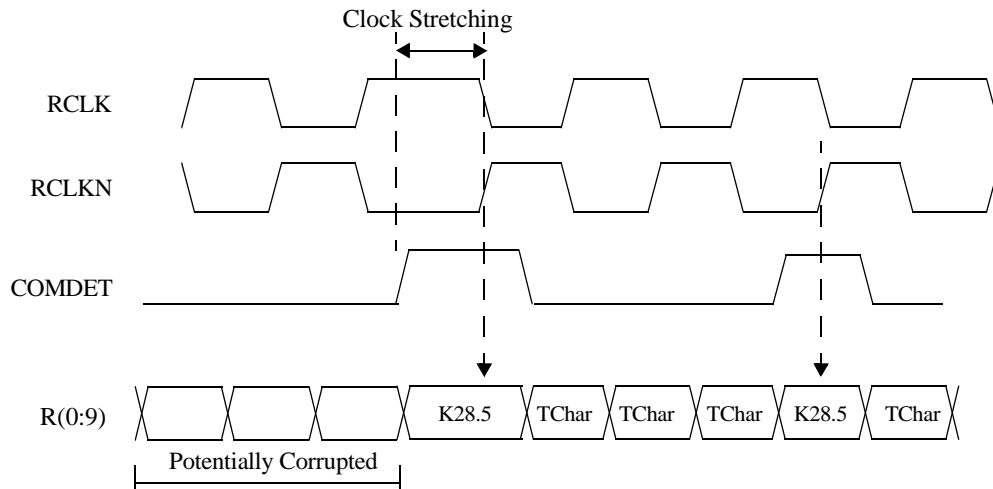

*TChar: 10-bit transmission character*

**Data Sheet**  
**VSC7123**

*10-Bit Transceiver for Fibre Channel and Gigabit Ethernet*

**Signal Detection**

The receiver has an output, SIGDET, indicating, when HIGH, that the RX input contains a valid Fibre Channel or Gigabit Ethernet signal. A combination of one analog and three digital checks are used to determine if the incoming signal contains valid data. SIGDET is updated every four RCLKs. If during the current period, all the four criteria are met, SIGDET will be HIGH during the next 4 RCLK period. If during the current period, any of the four criteria is not met, SIGDET will be LOW during the next 4 RCLK period.

- 1) Analog transition detection is performed on the input to verify that the signal swings are of adequate amplitude. The RX+/- input buffer contains a differential voltage comparator which will go HIGH if the differential peak-to-peak amplitude is greater than 400mV or LOW if under 200mV. If the amplitude is between 200mV and 400mV, the output is indeterminate.
- 2) Data on R(0:9) is monitored for all zeros (0000000000). If this pattern is encountered during the current RCLK interval, the SIGDET output will go LOW during the next four RCLK interval.
- 3) Data on R(0:9) is monitored for all ones (1111111111). If this pattern is encountered during the current RCLK interval, the SIGDET output will go LOW during the next four RCLK interval.
- 4) Data on R(0:9) is monitored for K28.5- (0011111010). Unlike previous patterns, the interval during which a K28.5- must occur is 64K+24 10-bit characters in length. Valid Fibre Channel or Gigabit Ethernet data will contain a K28.5- character during any period of this length. If a K28.5- is not detected during the monitoring period, SIGDET will go LOW during the next period.

The behavior of SIGDET is affected by EWRAP and ENCDDET as shown in Table 1.

**Table 1: Signal Detect Behavior**

<i>EWRAP</i>	<i>ENCDDET</i>	<i>COMDET</i>	<i>Transition Detect</i>	<i>All Zeros/ All Ones</i>	<i>K28.5 Presence</i>	<i>Mode</i>
0	0	Disabled	Enabled	Enabled	Enabled	Normal
0	1	Enabled	Enabled	Enabled	Disabled	SIGDET ignores commas
1	0	Disabled	Enabled	Disabled	Disabled	Rollback
1	1	Enabled	Enabled	Disabled	Disabled	Loopback

*Note: COMDET, RCLK, RCLKN and R(0:9) are unaltered by SIGDET.*

**JTAG Access Port**

A JTAG Access Port is provided to assist in board-level testing. Through this port, most pins can be accessed or controlled and all TTL outputs can be tri-stated. A full description of the JTAG functions on this device is available in “VSC7123/VSC7133 JTAG Access Port Functionality.”

**Figure 4: Transmit Timing Waveforms**

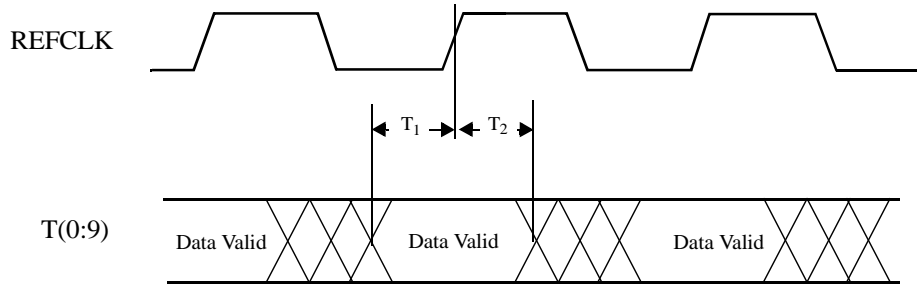

**Table 2: Transmit AC Characteristics**

Parameters	Description	Min	Typ	Max	Units	Conditions
$T_1$	T(0:9) Setup time to the rising edge of REFCLK	1.5	—	—	ns	Measured between the valid data level of T(0:9) to the 1.4V point of REFCLK.
$T_2$	T(0:9) hold time after the rising edge of REFCLK	1.0	—	—	ns	
$T_{SDR}, T_{SDF}$	TX+/TX- rise and fall time	—	—	300	ps	20% to 80%, 50Ω load to $V_{DD}-2.0$ .
$T_{LAT}$	Latency from rising edge of REFCLK to T0 appearing on TX+/TX-	8bc	—	8bc+4ns	ns	bc = Bit clocks ns = Nano second
<b>Transmitter Output Jitter Allocation</b>						
RJ	Random jitter (RMS)	—	5	8	ps.	Measured at SO+/-, 1 sigma deviation of 50% crossing point.
DJ	Serial data output deterministic jitter (pk-pk)	—	30	80	ps.	IEEE 802.3Z Clause 38.68, tested on a sample basis.

## Data Sheet VSC7123

## 10-Bit Transceiver for Fibre Channel and Gigabit Ethernet

**Figure 5: Receive Timing Waveforms**

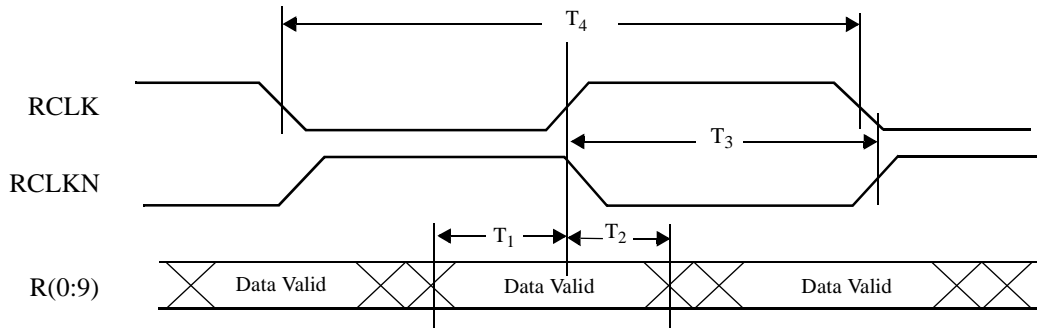
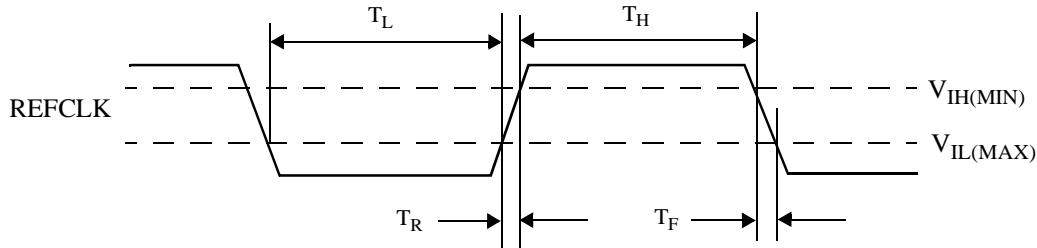

**Table 3: Receive AC Characteristics**

Parameters	Description	Min.	Max.	Units	Conditions
$T_1$	TTL Outputs Valid prior to RCLK/RCLKN rise	4.0 3.0	— —	ns	At 1.0625Gb/s At 1.25Gb/s
$T_2$	TTL Outputs Valid after RCLK or RCLKN rise	3.0 2.0	— —	ns	At 1.0625Gb/s At 1.25Gb/s
$T_3$	Delay between rising edge of RCLK to rising edge of RCLKN	$10 \times T_{RX}$ -500	$10 \times T_{RX}$ +500	ps	$T_{RX}$ is the bit period of the incoming data on Rx.
$T_4$	Period of RCLK and RCLKN	$1.98 \times T_{REFCLK}$	$2.02 \times T_{REFCLK}$	ps	Whether or not locked to serial data.
$T_R, T_F$	R(0:9), COMDET, SIGDET, RCLK and RCLKN rise and fall time	—	2.4	ns	Between $V_{IL(MAX)}$ and $V_{IH(MIN)}$ , into 10pf load.
$R_{LAT}$	Latency from RX to R(0:9)	12 bc + 1 ns	13 bc + 9 ns	bc ns	bc = bit clock ns = nano second
$T_{LOCK}^{(1)}$	Data acquisition lock time	—	1400	bc	8B/10B IDLE pattern. bc = bit clocks

NOTE: (1) Probability of recovery for data acquisition is 95% per Section 5.3 of FC-PH rev. 4.3.

**Figure 6: REFCLK Timing Waveforms**

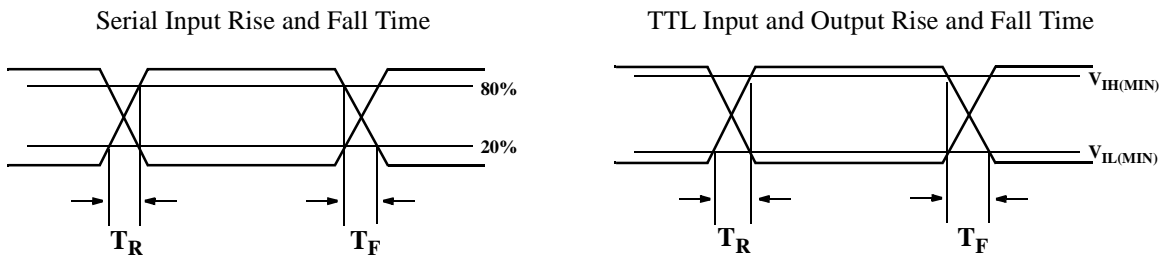

**Table 4: Reference Clock Requirements**

<i>Parameter</i>	<i>Description</i>	<i>Min</i>	<i>Max</i>	<i>Units</i>	<i>Conditions</i>
FR	Frequency Range	98	136	MHz	Range over which both transmit and receive reference clocks on any link may be centered.
FO	Frequency Offset	-200	200	ppm	Maximum frequency offset between transmit and receive reference clocks on one link.
DC	REFCLK duty cycle	35	65	%	Measured at 1.5V
$T_R, T_F$	REFCLK rise and fall time	—	1.5	ns	Between $V_{IL(MAX)}$ and $V_{IH(MIN)}$



**Figure 7: Parametric Measurement Information**



Receiver Input Eye Diagram Jitter Tolerance Mask

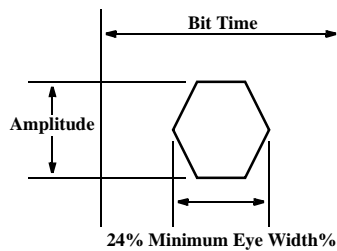

Parametric Test Load Circuit

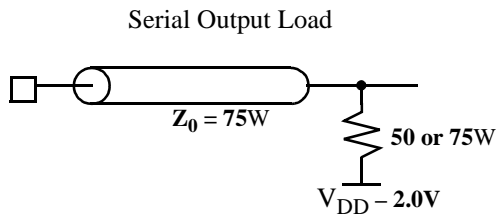

TTL AC Output Load

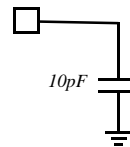

**Figure 8: Input Structures**

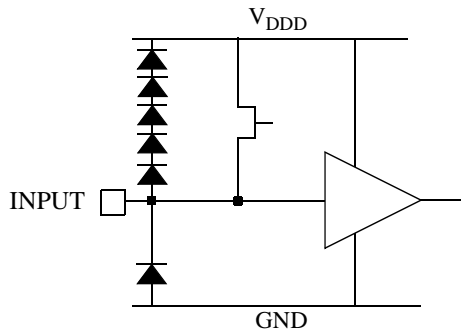

**TTL Inputs (not REFCLK)**

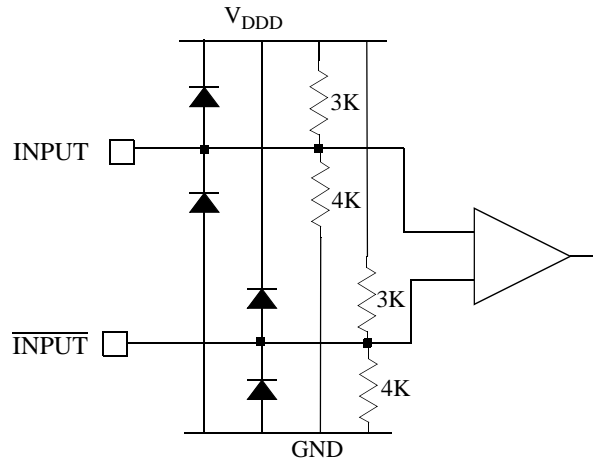

**High-Speed Input (RX+/RX-)**

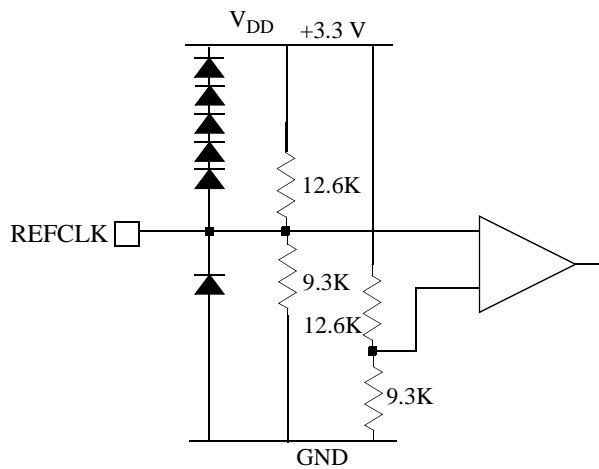

**REFCLK TTL Input**

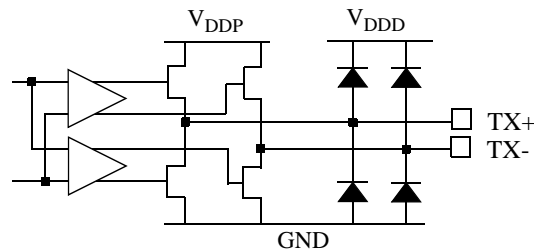

**High-Speed Outputs (TX+/-)**

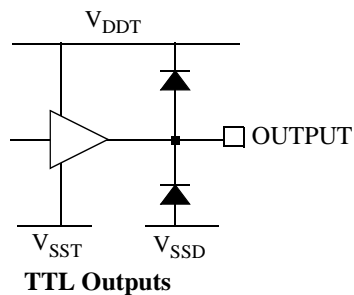

**TTL Outputs**

## Data Sheet VSC7123

10-Bit Transceiver for Fibre  
Channel and Gigabit Ethernet

### DC Characteristics (over recommended operating conditions)

Parameters	Description	Min	Typ	Max	Units	Conditions
$V_{OH}$	Output HIGH voltage (TTL)	2.4	—	—	V	$I_{OH} = -1.0$ mA
$V_{OL}$	Output LOW voltage (TTL)	—	—	0.5	V	$I_{OL} = +1.0$ mA
$V_{IH}$	Input HIGH voltage (TTL)	2.0	—	5.5	V	5V Tolerant Inputs
$V_{IL}$	Input LOW voltage (TTL)	0	—	0.8	V	—
$I_{IH}$	Input HIGH current (TTL)	—	50	500	$\mu$ A	$V_{IN} = 2.4$ V
$I_{IL}$	Input LOW current (TTL)	—	—	-500	$\mu$ A	$V_{IN} = 0.5$ V
$\Delta V_{OUT75}^{(1)}$	TX output differential peak-to-peak voltage swing	1200	—	2200	mVp-p	$75\Omega$ to $V_{DD} - 2.0$ V (TX+) - (TX-)
$\Delta V_{OUT50}^{(1)}$	TX output differential peak-to-peak voltage swing	1000	—	2200	mVp-p	$50\Omega$ to $V_{DD} - 2.0$ V (TX+) - (TX-)
$\Delta V_{IN}^{(1)}$	RX Input differential peak-to-peak input sensitivity	300	—	2600	mVp-p	Internally biased to $V_{DD}/2$ (RX+) - (RX-)
$V_{DD}$	Supply voltage	3.14	—	3.47	V	$3.3V \pm 5\%$
$P_D$	Power dissipation	—	650	900	mW	Outputs open, $V_{DD} = V_{DD}$ max
$I_{DD}$	Supply current (all supplies)	—	190	260	mA	Outputs open, Case temp = $95^\circ\text{C}$ , $V_{DD} = V_{DD}$ max
$I_{DDA}$	Analog supply current	—	—	100	mA	$V_{DDA} = V_{DDA}$ max

NOTE: (1) Refer to Application Note, AN-37, for differential measurement techniques.



**Absolute Maximum Ratings** <sup>(1)</sup>

Power Supply Voltage, (V <sub>DD</sub> ) .....	-0.5V to +4V
DC Input Voltage (PECL inputs).....	-0.5V to V <sub>DD</sub> +0.5V
DC Input Voltage (TTL inputs) .....	-0.5V to +5.5V
DC Output Voltage (TTL outputs) .....	-0.5V to V <sub>DD</sub> + 0.5V
Output Current (TTL outputs).....	±50mA
Output Current (PECL outputs).....	+50mA
Case Temperature Under Bias .....	-55°C to +125°C
Storage Temperature.....	-65°C to +150°C

**Recommended Operating Conditions**

Power Supply Voltage, (V <sub>DD</sub> ) .....	+3.3V±5%
Operating Temperature Range .....	0°C Ambient to +95°C Case Temperature

*Note: (1) CAUTION: Stresses listed under “Absolute Maximum Ratings” may be applied to devices one at a time without causing permanent damage. Functionality at or above the values listed is not implied. Exposure to these values for extended periods may affect device reliability.*

**ESD Ratings**

Proper ESD procedures should be used when handling this product. The VSC7123 is rated to the following ESD voltages based on the human body and charge device models:

1. All pins are rated at or above 1000V (charge device model).
2. All pins are rated at or above 2000V (human body model).

## Package Pin Descriptions

**Figure 9: Pin Diagram**

(Top View)

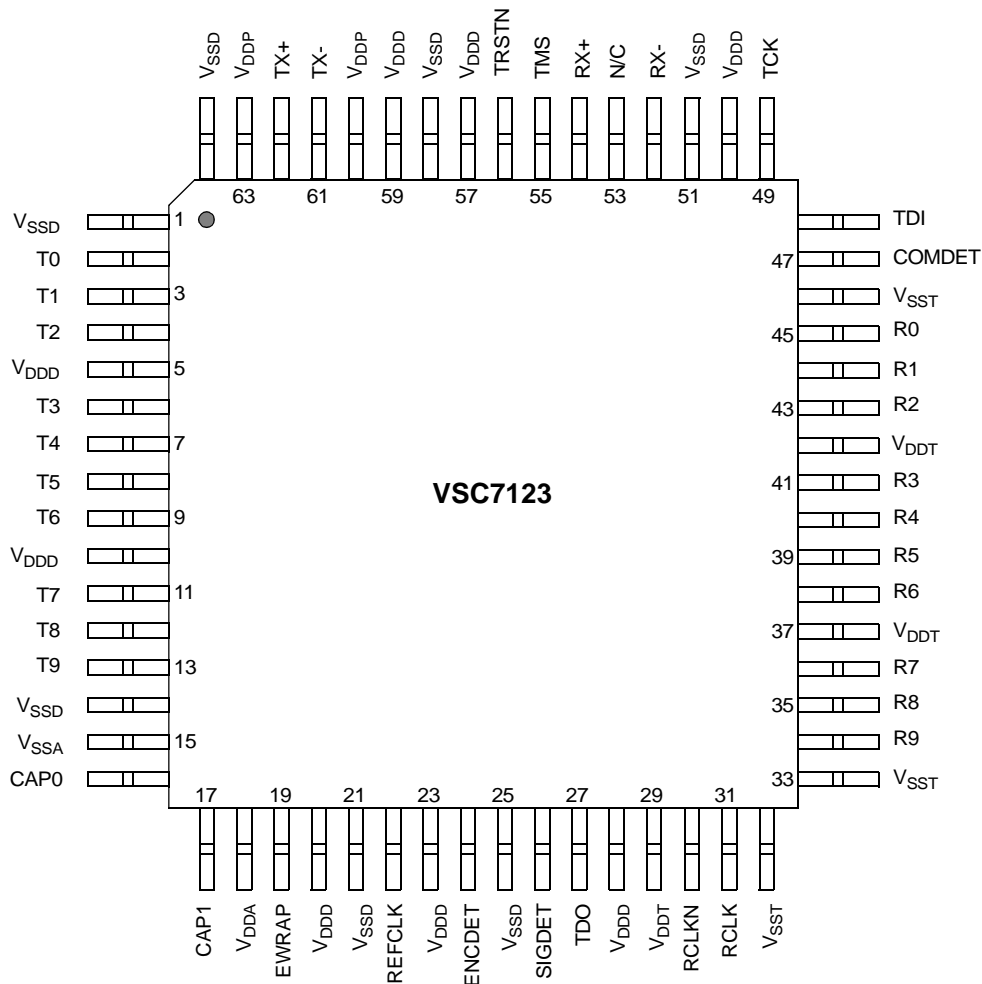

**Table 5: Pin Identifications**

Pin #	Name	Description
2,3,4,6 7,8,9,11 12,13	T0,T1,T2,T3 T4,T5,T6,T7 T8,T9	INPUTS - TTL: 10-bit transmit character. Parallel data on this bus is clocked in on the rising edge of REFCLK. The data bit corresponding to T0 is transmitted first.
22	REFCLK	INPUT - TTL: This rising edge of this clock latches T(0:9) into the input register. It also provides the reference clock, at one tenth the baud rate to the PLL.

10-Bit Transceiver for Fibre  
Channel and Gigabit Ethernet

Data Sheet  
**VSC7123**

Pin #	Name	Description
62, 61	TX+, TX-	OUTPUTS - Differential PECL (AC-coupling recommended): These pins output the serialized transmit data when EWRAP is LOW. When EWRAP is HIGH, TX+ is HIGH and TX- is LOW.
45,44,43,41 40,39,38,36 35,34	R0,R1,R2,R3 R4,R5,R6,R7 R8,R9	OUTPUTS - TTL: 10-bit received character. Parallel data on this bus is clocked out on the rising edges of RCLK and RCLKN. R0 is the first bit received on RX+/RX-.
19	EWRAP	INPUT - TTL: LOW for normal operation. When HIGH, an internal loopback path from the transmitter to the receiver is enabled. TX+ is held HIGH and TX- is held LOW.
54, 52	RX+, RX-	INPUTS - Differential PECL (AC-coupling recommended): The serial receive data inputs selected when EWRAP is LOW. Internally biased to VDD/2, with 3.3KΩ resistors from each input pin to VDD and GND.
31, 30	RCLK, RCLKN	OUTPUT - Complementary TTL: Recovered clocks derived from 1/20 <sup>th</sup> of the RX+/- data stream. Each rising transition of RCLK or RCLKN corresponds to a new word on R(0:9).
24	ENCDET	INPUT - TTL: Enables COMDET and word resynchronization when HIGH. When LOW, keeps current word alignment and disables COMDET.
47	COMDET	OUTPUT - TTL: This output goes HIGH for half of an RCLK period to indicate that R(0:9) contains a comma character ('0011111XXX'). COMDET will go HIGH only during a cycle when RCLKN is rising. COMDET is enabled by ENCDET being HIGH.
26	SIGDET	OUTPUT - TTL SIGnal DETect. This output goes HIGH when the RX input contains a valid Fibre Channel or Gigabit Ethernet signal. A LOW indicates an invalid signal.
16, 17	CAPO, CAPI	ANALOG: Differential capacitor for the CMU's VCO, 0.1 μF nominal.
49	TCK	INPUT - TTL: JTAG clock input. Not normally connected.
48	TDI	INPUT - TTL: JTAG data input. Not normally connected.
55	TMS	INPUT - TTL: JTAG mode select input. Normally tied to V <sub>DDD</sub>
56	TRSTN	INPUT - TTL: JTAG reset input. Tie to V <sub>SSD</sub> for normal operation.
27	TDO	OUTPUT - TTL: JTAG data output. Normally tri-stated.
18	VDDA	Analog Power Supply
15	VSSA	Analog Ground
5,10,20,23 28,50,57,59	VDDD	Digital Logic Power Supply
1,14,21,25 51,58,64	VSSD	Digital Logic Ground
29, 37, 42	VDDT	TTL Output Power Supply
32, 33, 46	VSST	TTL Output Ground
60,63	VDDP	PECL I/O Power Supply
53	N/C	No internal connection

**Data Sheet**  
**VSC7123**

**10-Bit Transceiver for Fibre Channel and Gigabit Ethernet**

**Package Information: 64-pin PQFP**

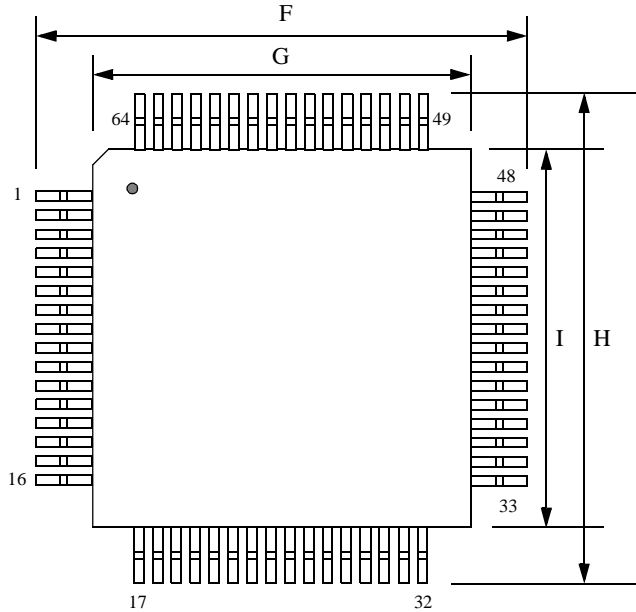

Item	10mm	14mm	Tolerance
A	2.45	2.35	MAX
A2	2.00	2.00	+0.10/-0.05
E	0.22	0.35	±0.05
F	13.20	17.20	±0.25
G	10.00	14.00	±0.10
H	13.20	17.20	±0.25
I	10.00	14.00	±0.10
J	0.88	0.88	+0.15/-0.10
K	0.50	0.80	BASIC

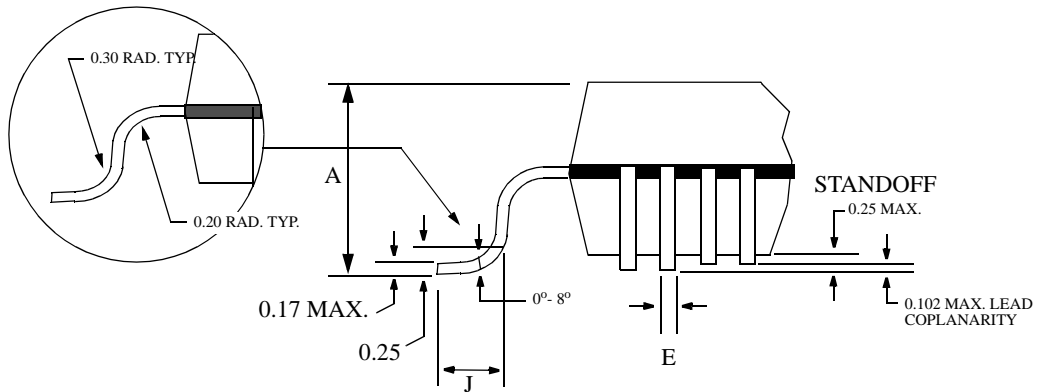
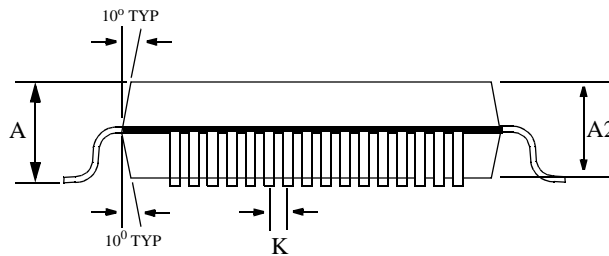

NOTES:  
Drawing not to scale.  
All units in mm unless otherwise noted.

10-Bit Transceiver for Fibre  
Channel and Gigabit Ethernet

Data Sheet  
**VSC7123**

**Package Information: 64-pin TQFP**

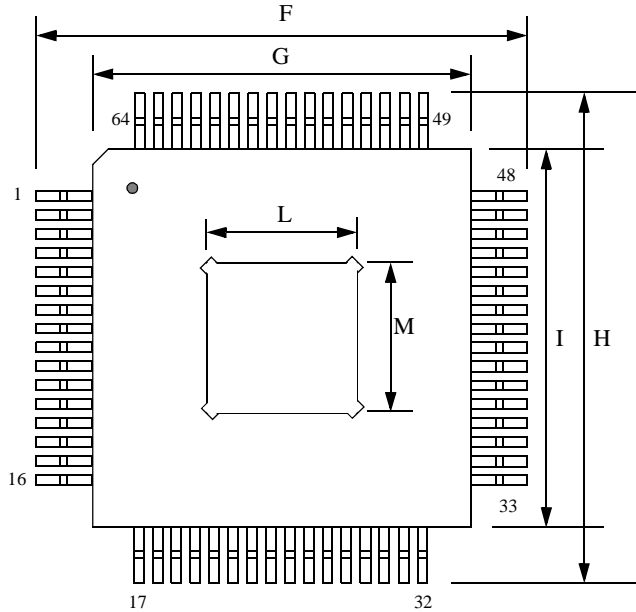

Item	10 mm	Tolerance
A	1.20	MAX
A1	0.10	±0.05
A2	1.00	±0.05
E	0.22	±0.05
F	12.00	BASIC
G	10.00	BASIC
H	12.00	BASIC
I	10.00	BASIC
J	0.60	±0.15
K	0.50	BASIC
L	3.80	BASIC
M	3.80	BASIC

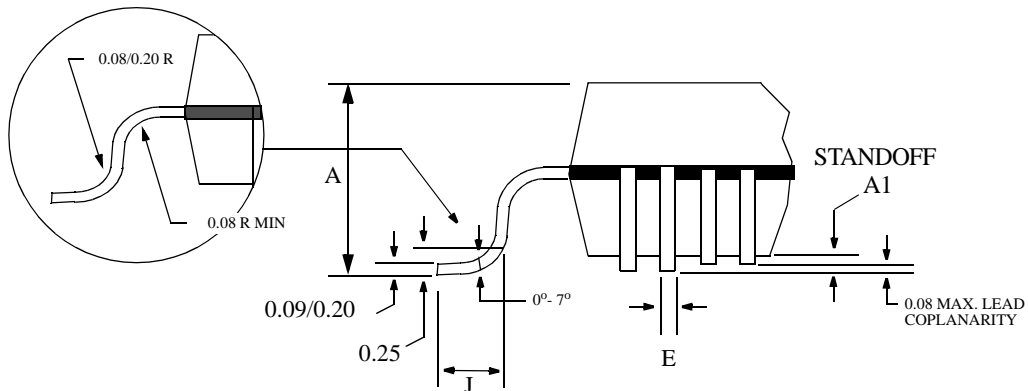
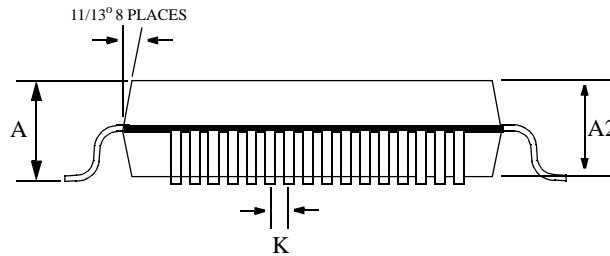

NOTES:  
Drawing not to scale.  
All units in mm unless otherwise noted.



## Data Sheet VSC7123

10-Bit Transceiver for Fibre  
Channel and Gigabit Ethernet

### Package Thermal Considerations

The VSC7123 is packaged in a 14mm, thermally-enhanced PQFP with an internal heat spreader a 10 mm, thermally enhanced PQFP and a 10mm cavity-down, exposed pad TQFP. These packages use industry-standard EIAJ footprints, but have been enhanced to improve thermal dissipation. The construction of the packages is shown in Figure 10.

Figure 10: PQFP Package Cross Section

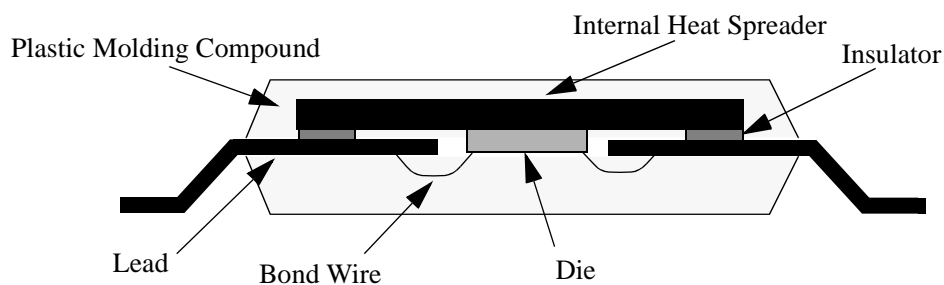

Table 6: Thermal Resistance

Symbol	Description	10mm PQFP	14mm PQFP	10mm TQFP	Units
$\theta_{jc}$	Thermal resistance from junction-to-case	10	9.5	7.0	$^{\circ}\text{C}/\text{W}$
$\theta_{ca}$	Thermal resistance from case-to-ambient in still air including conduction through the leads.	50	29	40	$^{\circ}\text{C}/\text{W}$
$\theta_{ca-100}$	Thermal resistance from case-to-ambient with 100 LFM airflow	41	26	38	$^{\circ}\text{C}/\text{W}$
$\theta_{ca-200}$	Thermal resistance from case-to-ambient with 200 LFM airflow	37	24	35	$^{\circ}\text{C}/\text{W}$
$\theta_{ca-400}$	Thermal resistance from case-to-ambient with 400 LFM airflow	32	21	33	$^{\circ}\text{C}/\text{W}$
$\theta_{ca-600}$	Thermal resistance from case-to-ambient with 600 LFM airflow	28	18	30	$^{\circ}\text{C}/\text{W}$

The VSC7123 is designed to operate with a case temperature up to  $95^{\circ}\text{C}$ . The user must guarantee that the case temperature specification is not violated. With the thermal resistances shown in Table 7, the 10mm thermally-enhanced PQFP package can operate in still air ambient temperatures of  $50^{\circ}\text{C}$  [ $50^{\circ}\text{C} = 95^{\circ}\text{C} - 0.9\text{W} * 50 \text{ C/W}$ ]. The 14mm thermally-enhanced PQFP package can operate in still air ambient temperatures of  $69^{\circ}\text{C}$  [ $69^{\circ}\text{C} = 95^{\circ}\text{C} - 0.9\text{W} * 29 \text{ C/W}$ ]. The TQFP package can operate in a still air ambient temperature of  $59^{\circ}\text{C}$  [ $59^{\circ}\text{C} = 95^{\circ}\text{C} - 0.9\text{W} * 40 \text{ C/W}$ ]. If the ambient air temperature exceeds these limits, a form of cooling through a heatsink or an increase in airflow must be provided.

### Moisture Sensitivity Level

This device is rated at a Moisture Sensitivity Level 3 rating with maximum floor life of 168 hours at  $30^{\circ}\text{C}$ , 60% relative humidity. Please refer to Application Note AN-20 for appropriate handling procedures.

## Ordering Information

The part number for this product is formed by a combination of the device number and the package style.

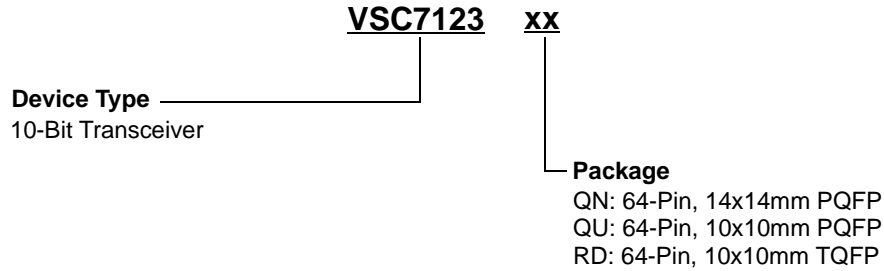

## Marking Information

The package is marked with three lines of text as shown in Figure 11 (QU package shown).

**Figure 11: Package Marking Information**

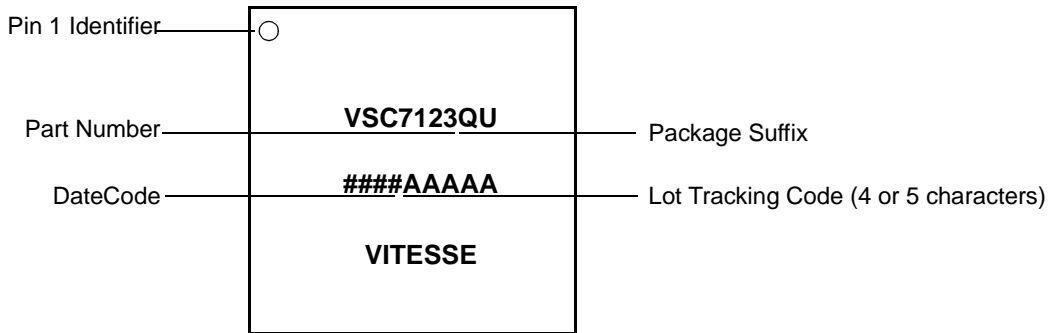

### Notice

Vitesse Semiconductor Corporation (“Vitesse”) provides this document for informational purposes only. All information in this document, including descriptions of features, functions, performance, technical specifications and availability, is subject to change without notice at any time. Nothing contained in this document shall be construed as extending any warranty or promise, express or implied, that any Vitesse product will be available as described or will be suitable for or will accomplish any particular task.

Vitesse products are not intended for use in life support appliances, devices or systems. Use of a Vitesse product in such applications without written consent is prohibited.