

**M65841SP****DIGITAL REVERBE (DIGITAL DELAY)****DESCRIPTION**

The M65841SP is an IC to generate reverberation effect.

With synthesized outputs for five digital delay lines, this IC is capable of producing the same reverberation effect as that in a church and bathroom, and is suitable for application to the reverbe unit of mini-component stereo sets, laser disc players, "karaoke" equipment, electronic musical instruments etc.

Since this IC is a higher-performance and pin-compatible version of the conventional M-50194AP, it can replace the conventional one easily to improve the performance.

**FEATURES**

- Built-in input low-pass filter and memory
- Reverbe, echo or surround mode is selectable.
  - Reverbe mode...short : Five lines for 41.0 to 82.0msec
  - Long : Five for 82.0 to 163.8msec
  - Echo mode ..... Eight steps for 20.5 to 163.8msec
  - Surround mode ..... Eight steps for 4.1 to 41.0msec
 Feedback amount is adjustable for each mode.
- ADM digital delay allows a low-cost delay system with wide dynamic range and low distortion.
  - (Reverbe mode : DR = 88dB as standard, THD = 0.7% as standard, Surround mode : DR = 92dB as standard, THD = 0.3% as standard)
- Operation mode and delay time can be selected in two modes, easy mode in which operation mode and delay time are controlled by 5-bit parallel data, and microcomputer mode in which they are controlled by serial data.

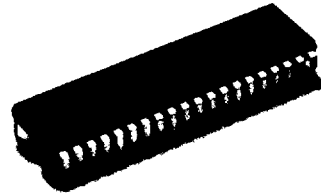

Outline 40P4B

1.778mm pitch 600mil SDIP  
(13.0mm × 36.7mm × 3.8mm)

- Built-in auto mute function prevents noise generation when power is turned ON and when delay time is changed.
- Built-in auto reset circuit

**RECOMMENDED OPERATING CONDITIONS**

Supply voltage range.....  $V_{CC}, V_{DD} = 4.5$  to  $5.5V$   
Rated supply voltage.....  $V_{CC}, V_{DD} = 5V$

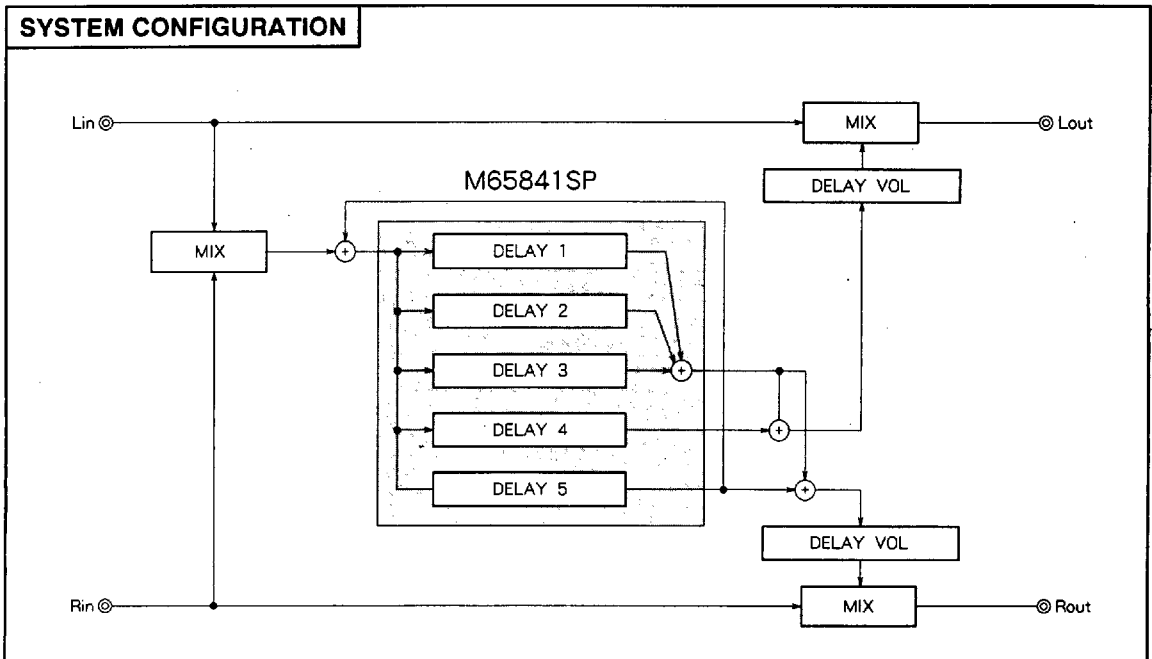
**SYSTEM CONFIGURATION**

6249826 0022079 954

# M65841SP

## DIGITAL REVERBE (DIGITAL DELAY)

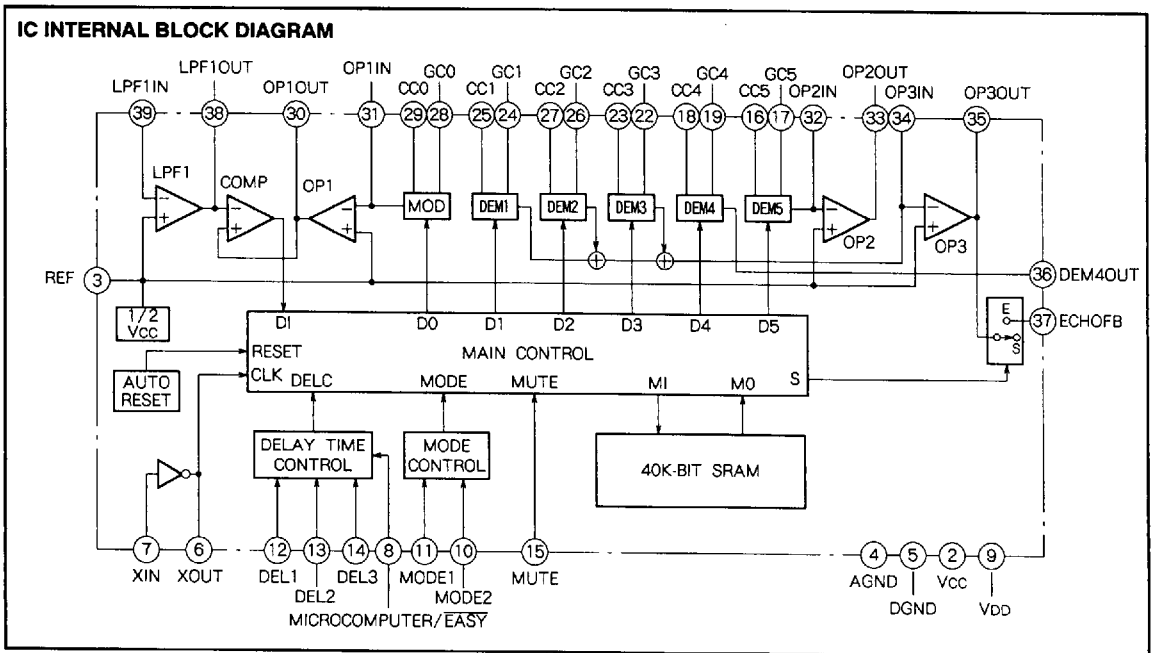
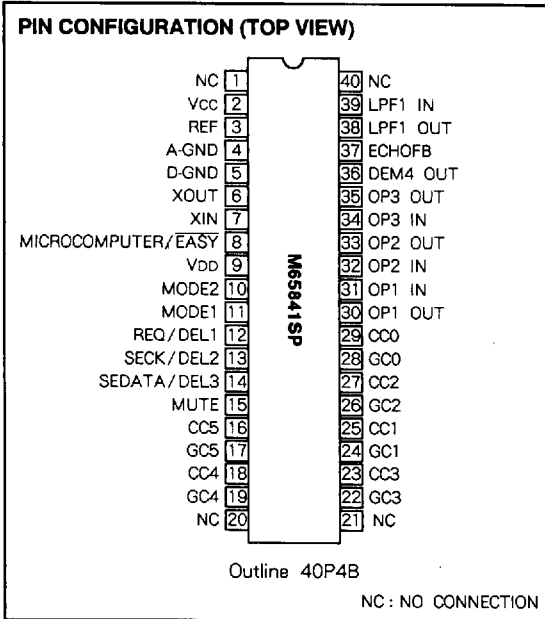

## DIGITAL REVERBE (DIGITAL DELAY)

## PIN DESCRIPTION

Pin No.	Symbol	Name	I/O	Function	Standard output voltage
①	NC		-		-
②	Vcc	Analog power supply	-	To apply 4.5V to 5.5V (rating: 5V)	5V
③	REF	Reference	-	Analog reference voltage $\approx 1/2V_{cc}$	2.5V
④	A GND	Analog GND	-		-
⑤	D GND	Digital GND	-		-
⑥	Xout	Clock generator output	0		-
⑦	XIN	Clock generator input	1		-
⑧	MICROCOMPUTER/ EASY	Microcomputer/EASY	1	H = Microcomputer mode: control by serial data L = Easy mode: control by parallel data	-
⑨	Vdd	Digital power supply	-	To apply 4.5V to 5.5V (rating 5V)	5V
⑩	MODE2	Mode 2	1	Reverb/echo/surround mode selection input Refer to the paragraph of FUNCTIONAL DESCRIPTION, item (1).	-
⑪	MODE1	Mode 1	1	In the microcomputer mode, fix the pin at L (Mode 2) H (Mode 1).	-
⑫	REQ/DEL1	Request/delay 1	1↓	H=Microcomputer mode:data request signal input L=Easy mode:control time setting data 1 input	-
⑬	SECK/DEL2	Serial clock/delay 2	1↓	H=Microcomputer mode:serial data shift clock input L=Easy mode:delay time setting data 2 input	-
⑭	SEDATA/DEL3	Serial clock/delay 3	1↓	H=Microcomputer mode:serial data input L=Easy mode:delay time setting data 3 input	-
⑮	MUTE	Mute	1↓	Mute control, H = mute	-
⑯	CC5	Current control 5	-	ADM control of demodulator 5	0.4V when no signal
⑰	GC5	Gain control 5	-	Gain control of demodulator 5	
⑱	CC4	Current control 5	-	ADM control of demodulator 4	
⑲	GC4	Gain control 4	-	Gain control of demodulator 4	
⑳	NC		-		-
㉑	NC		-		-
㉒	GC3	Gain control 3	-	Gain control of demodulator 3	0.4V when no signal
㉓	CC3	Current control 3	-	ADM control of demodulator 3	
㉔	GC1	Gain control 1	-	Gain control of demodulator 1	
㉕	CC1	Current control 1	-	ADM control of demodulator 1	
㉖	GC2	Gain control 2	-	Gain control of demodulator 2	
㉗	CC2	Current control 2	-	ADM control of demodulator 2	
㉘	GC0	Gain control 0	-	Gain control of modulator 0	
㉙	CC0	Current control 0	-	ADM control of modulator 0	
㉚	OP1 OUT	Operational amplifier 1 output	0	To form modulating integrator by connecting external capacitor and resistor	2.5V
㉛	OP1 IN	Operational amplifier 1 input	1		2.5V
㉜	OP2 IN	Operational amplifier 2 input	1		2.5V
㉝	OP2 OUT	Operational amplifier 2 output	0	To form demodulating integrator by connecting external capacitor and resistor	2.5V
㉞	OP3 IN	Operational amplifier 3 input	1		2.5V
㉟	OP3 OUT	Operational amplifier 3 output	0	To form demodulating integrator by connecting external capacitor and resistor	2.5V
㊱	DEM4 OUT	DEM4 output	0	Demodulator 4 output	-
㊲	ECHOFB	Echo feedback	0	Feedback control for echo mode	2.5V
㊳	LPF1 OUT	Low-pass filter 1 output	0		2.5V
㊴	LPF1 IN	Low-pass filter 1 input	1	To form input low-pass filter by connecting external capacitor and resistor	2.5V
㊵	NC		-		-

## DIGITAL REVERBE (DIGITAL DELAY)

## ABSOLUTE MAXIMUM RATINGS (Ta = 25°C, unless otherwise noted)

Symbol	Parameter	Ratings	Unit
Vcc	Supply voltage	6.5	V
Icc	Circuit current	150	mA
Pd	Power dissipation	1.7	W
Topr	Operating temperature	-20 to 75	°C
Tstg	Storage temperature	-40 to 125	°C

## RECOMMENDED OPERATING CONDITIONS

Symbol	Parameter	Test conditions	Limits			Unit
			Min	Typ	Max	
Vcc	Supply voltage		4.5	5	5.5	V
VDD	Supply voltage		4.5	5	5.5	V
Vcc-VDD	Vcc-VDD potential difference		-0.3	0	0.3	V
fck	Clock frequency		3	4	6	MHz
VIH	Input voltage (H level)		0.7VDD	-	VDD	V
VIL	Input voltage (L level)		0	-	0.3VDD	V
fSECK	Microcomputer mode serial clock		-	-	4	MHz

## ELECTRICAL CHARACTERISTICS (Vcc = 5V, f = 1kHz, Vi = 100mVrms, fck = 4MHz, Ta = 25°C, unless otherwise noted)

Symbol	Parameter	Test conditions	Limits			Unit		
			Min	Typ	Max			
Icc	Circuit current	No signal input	-	30	60	mA		
VREF	Reference voltage		2.0	2.5	3.0	V		
Gv	I-O voltage gain	RL = 47k Ω	-2.5	-0.5	1.5	dB		
Gr	Low level I-O voltage gain	Vi = 2mVrms	-3.5	-0.5	2.5	dB		
Vomax	Maximum output voltage	THD = 10%	0.7	1.0	-	Vrms		
THD	Output distortion	30kHz LPF						
		Reverbe mode	fs = 500kHz	-	0.3	1.0	%	
		Echo mode	fs = 250kHz	-	0.7	1.5	%	
		Surround mode	fs = 1MHz	-	0.3	1.0	%	
No	Output noise voltage	Low sample rate side	Reverbe mode	Average	-	-88	-75	dBv
				± peak	-	200	800	μV
		DIN-AUDIO	Echo mode	Average	-	-92	-80	dBv
				± peak	-	100	400	μV
		Surround mode	Average	-	-92	-85	dBv	
			± peak	-	100	230	μV	
SVRR	Supply voltage reduction ratio	Δ Vcc = -20dBv, f = 100Hz	-	-40	-25	dB		
tMUTE	Mute time	Reverbe/echo mode	515	520	525	msec		
		Surround mode	122	127	132	msec		
tM1	Mute operation time (Internal delay time change)	Reverbe/echo mode	257	260	263	msec		
tM2	Mute operation time (Mute OFF)	At time of (a) changing delay time, and (b) turning on power	257	260	263	msec		
tM1	Mute operation time (Internal delay time change)	Surround mode	61	64	67	msec		
tM2	Mute operation time (Mute OFF)	At time of (a) changing delay time, and (b) turning on power	61	64	67	msec		
IiHA	Input leak current (H level)	Vi = 5V, pins 8, 10, 11	-	-	1	μA		
IiLA	Input leak current (L level)	Vi = 0V, pin 8, 10, 11	-	-	-1	μA		
Rpd	Pulldown resistance	Pins 12, 13, 14, 15	25	50	75	kΩ		

**FUNCTION DESCRIPTION**

**(1) Operation mode**

MODE1 (Pin ①)	MODE2 (Pin ⑩)	Mode	ECHOFB Output
L	H	Surround mode	OFF
H	H	Echo mode	ON
H	L	Reverbe mode	OFF
L	L	Test mode	-

**(2) Delay time**

DEL1	DEL2	DEL3	Surround mode		Echo mode		Reverbe mode	
			fs	Td	fs	Td	fs	Td
L	L	L	1M	4.1	500k	500k	500k	81.9
H	H	10.2		41.0				49.2
H	L	14.3		61.4				69.6
L	H	20.5		81.9				41.0
H	L	H	1M	24.6	250k	250k	250k	163.8
L	L	30.7		122.9				98.3
L	H	34.8		139.3				98.3
H	H	41.0		163.8				81.9

fs = Sampling frequency (Hz)  
Td = Delay time (msec)

Note 1. In the reverbe mode, delay time changes according to the polarity at DEL3 (and independent of the polarity at DEL 1 or DEL2).

**(3) Easy mode**

When microcomputer/ $\overline{\text{EASY}} = \text{L}$ , operation mode and delay time can be controlled by parallel data input to each terminal

pin MODE1 ) Operation mode...Refer to (1) Operation mode.  
MODE2 )

DEL1 ) Delay time...Refer to (2) Delay time.  
DEL2 )  
DEL3 )

**(4) Microcomputer mode**

When microcomputer/ $\overline{\text{EASY}} = \text{H}$ , operation mode and delay time can be controlled by serial data input at the following timing.

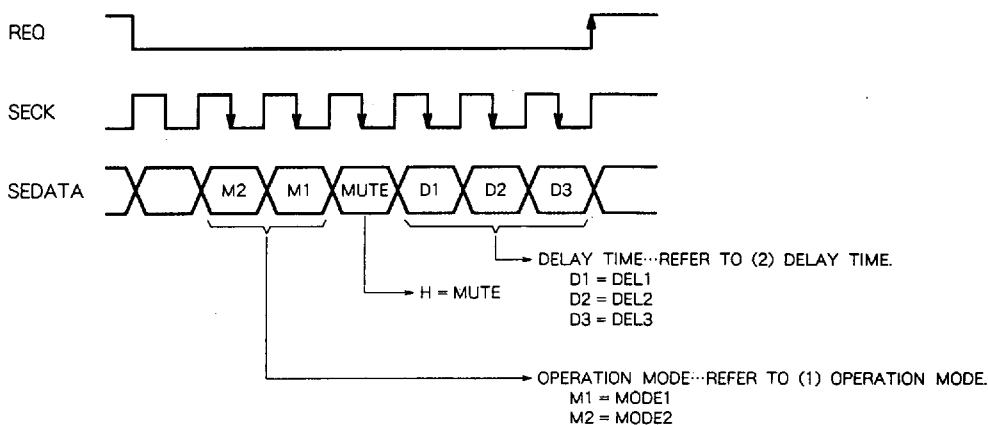

SEDATA is read at each fall of SECK, with the last six bits loaded at rise of REQ.

DIGITAL REVERBE (DIGITAL DELAY)

Input timing of REQ, SECK and SEDATA in the micro-computer mode is shown below :

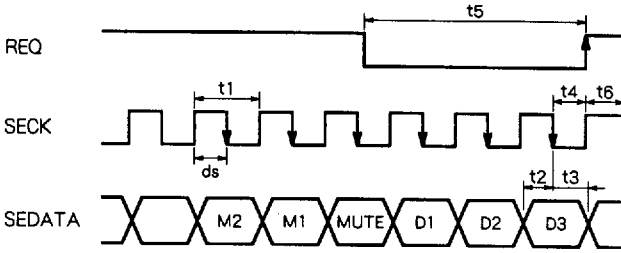

Symbol	Name	min	typ	max	Unit
t1	SECK clock duration	250	-	-	nsec
ds	SECK pulse duty	-	50	-	%
t2	SEDATA setup time	100	t1/2	-	nsec
t3	SEDATA hold time	100	t1/2	-	nsec
t4	REQ hold time	100	-	-	nsec
t5	REQ pulse duration	100	-	-	nsec

Note. No specification for t6

(5) Reverbe construction

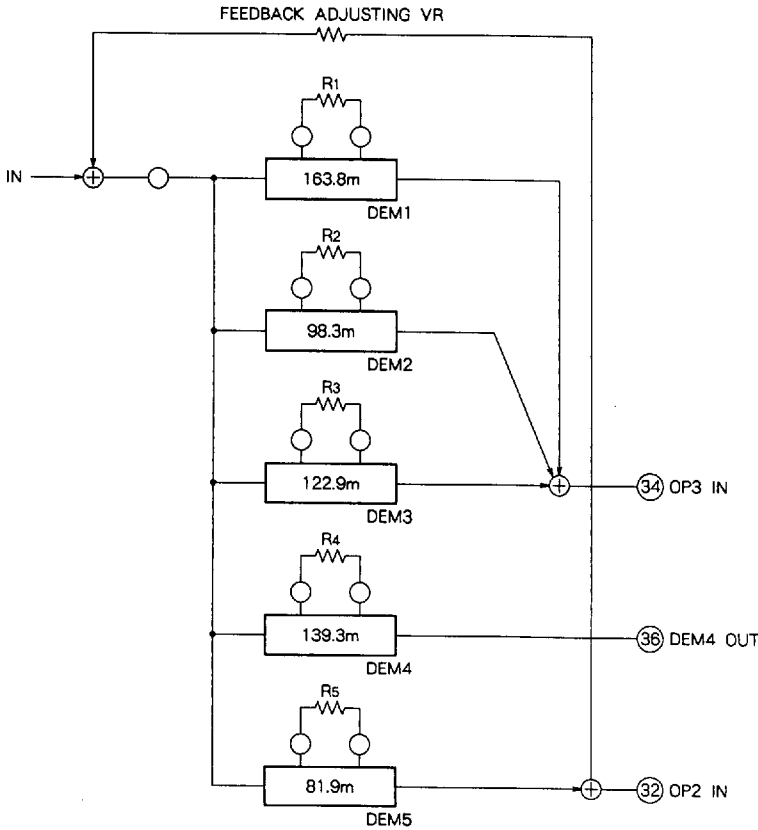

R1~R5 : Delay gain adjusting resistors  
(Each delay time value is at fs = 250kHz)

DIGITAL REVERBE (DIGITAL DELAY)

(6) Selection of demodulator

Allocation of demodulator and delay time (msec)

Demodulator	Surround mode	Echo mode	Reverbe mode	
			fs=500kHz	fs=250kHz
DEM1	-	-	81.9	163.8
DEM2	4.1~41.0	20.5~163.8	49.2	98.3
DEM3	-	-	61.4	122.9
DEM4	-	-	69.6	139.3
DEM5	-	-	41.0	81.9

Each modulator is turned OFF when connected as follows in the reverbe mode, so that unnecessary delay time can be eliminated.

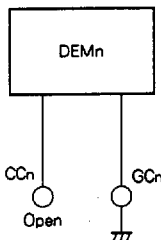

However, demodulator 2 is used in the surround/echo mode. Therefore, demodulator 2 cannot be turned OFF if operation mode is switched over from the surround/echo mode to reverbe mode.

(7) Gain setting

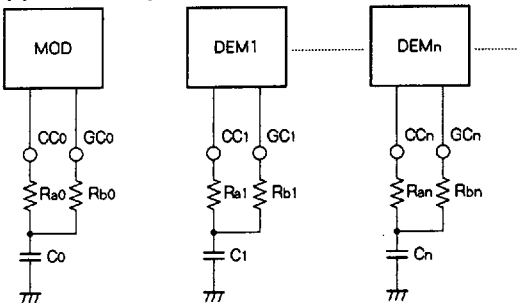

The gain of DEMn (demodulator n) is determined by the ratio to Rb0 connected to the modulator.

$$A_n = \frac{R_{b0}}{R_{bn}}$$

$$R_{an} = \frac{R_{bn}}{10}$$

$$C_n = A_n \cdot C_0$$

Typical constants on the modulator side :

$$R_{a0} = 7.5k \Omega$$

$$R_{b0} = 75k \Omega$$

$$C_0 = 0.33 \mu F$$

However, the gain in the surround/echo mode is determined by Rb2 because demodulator 2 is used.

(8) Feedback output

In the echo mode, signal is output from ECHOFB. Therefore, optimum multiple delay can automatically be obtained by feeding back the signal through appropriate feedback resistance from ECHOFB to the input side.

There is no feedback output in the surround or reverbe mode.

(9) Muting

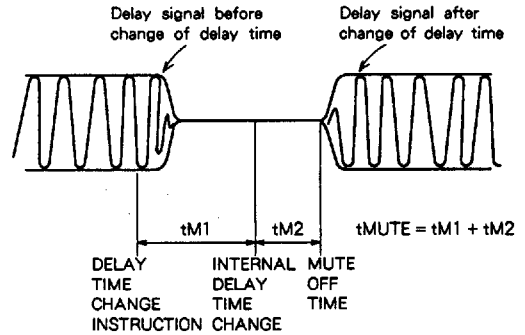

(a) When delay time is changed

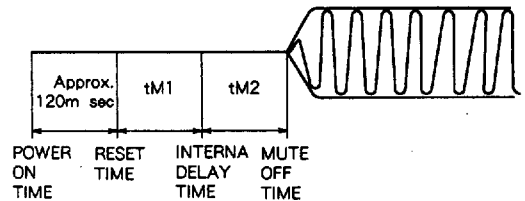

(b) When power is turned ON

(10) Reset

When reset circuit is activated, operation mode is switched to the echo mode, and Td is set to 163.8msec.

$$\begin{pmatrix} \text{MODE1} = \text{H} \\ \text{MODE2} = \text{H} \end{pmatrix}$$

$$\begin{pmatrix} \text{DEL1} = \text{H} \\ \text{DEL2} = \text{H} \\ \text{DEL3} = \text{H} \\ \text{MUTE} = \text{L} \end{pmatrix}$$

TEST CIRCUIT

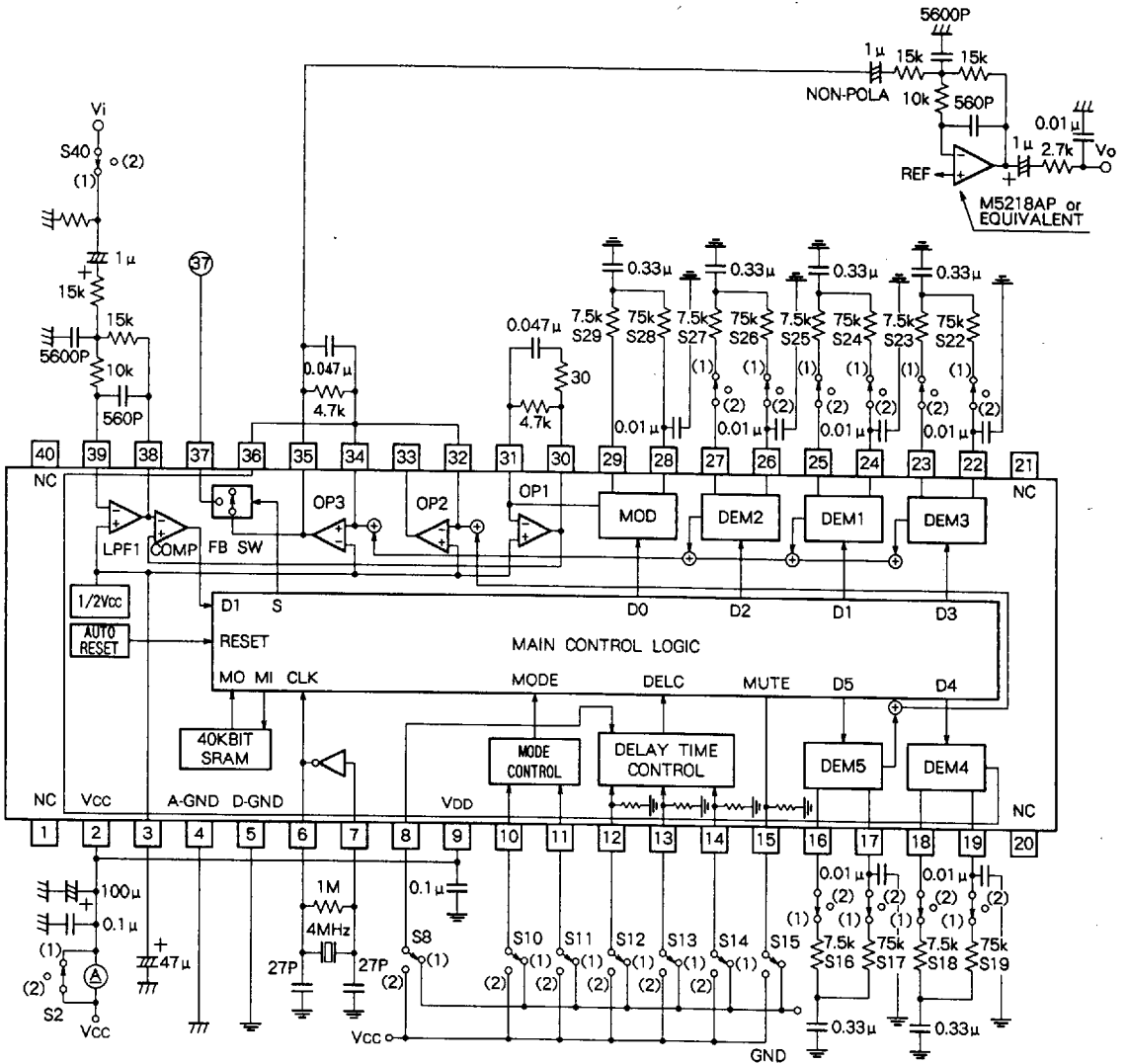

⏏ DIGITAL GND  
 ⏏ ANALOG GND

Units Resistance : Ω  
 Capacitance : F



DIGITAL REVERBE (DIGITAL DELAY)

TEST CONDITIONS

Switch setting

※...See the note under the table. \*...1 or 2

Symbol	Parameter	Mode	Sampling frequency	S02	S08	S10	S11	S12	S13	S14	S15	S16	S17	S18	S19	S22	S23	S24	S25	S26	S27	S40	Remark		
Icco	Circuit current	Surround/echo/reverbe		2	1	*	*	1	1	1	1	1	1	1	1	1	1	1	1	1	1	2	No signal		
Gvs	Voltage gain	Surround	1MHz	1	↓	2	1	*	*	*	↓	↓	↓	↓	↓	↓	↓	↓	↓	↓	↓	1	Gv = 20log (Vo/Vi) In the reverbe mode, measurement is made for individual demodulators.		
Gve1		Echo	500kHz	↓	↓	2	2	*	*	1	↓	↓	↓	↓	↓	↓	↓	↓	↓	↓	↓	↓			
Gve2		Echo	250kHz	↓	↓	2	2	*	*	2	↓	↓	↓	↓	↓	↓	1	1	1	1	1	↓			
Gvr1		Reverbe	500kHz	↓	↓	1	2	1	1	1	↓	↓	↓	↓	↓	↓	※	※	※	※	※	※		↓	
Gvr2	Reverbe	250kHz	↓	↓	1	2	1	1	2	↓	↓	↓	↓	↓	↓	※	※	※	※	※	※	↓			
Tdsa	Delay time	Surround	1MHz	↓	↓	2	1	1	1	1	↓	↓	↓	↓	↓	↓	1	1	1	1	1	↓	Refer to FUNCTIONAL DESCRIPTION. In the reverbe mode, measurement is made for individual demodulators.		
Tdsb				↓	↓	↓	2	2	1	↓	↓	↓	↓	↓	↓	↓	↓	↓	↓	↓	↓	↓		↓	
Tdsc				↓	↓	↓	2	1	1	↓	↓	↓	↓	↓	↓	↓	↓	↓	↓	↓	↓	↓		↓	↓
Tdscd				↓	↓	↓	1	2	1	↓	↓	↓	↓	↓	↓	↓	↓	↓	↓	↓	↓	↓		↓	↓
Tdse				↓	↓	↓	2	1	2	↓	↓	↓	↓	↓	↓	↓	↓	↓	↓	↓	↓	↓		↓	↓
Tdsf				↓	↓	↓	1	1	2	↓	↓	↓	↓	↓	↓	↓	↓	↓	↓	↓	↓	↓		↓	↓
Tdsg				↓	↓	↓	1	2	2	↓	↓	↓	↓	↓	↓	↓	↓	↓	↓	↓	↓	↓		↓	↓
Tdsh				↓	↓	↓	1	2	2	2	↓	↓	↓	↓	↓	↓	↓	↓	↓	↓	↓	↓		↓	↓
Tdea		Echo	500kHz	↓	↓	↓	2	1	1	1	↓	↓	↓	↓	↓	↓	↓	↓	↓	↓	↓	↓		↓	
Tdeb				↓	↓	↓	2	2	1	↓	↓	↓	↓	↓	↓	↓	↓	↓	↓	↓	↓	↓		↓	
Tdec				1	1	2	2	1	2	1	1	1	1	1	1	1	1	1	1	1	1	1		1	
Tdee				1	1	2	2	2	1	2	1	1	1	1	1	1	1	1	1	1	1	1		1	
Tdef		250kHz	↓	↓	2	↓	1	1	↓	↓	↓	↓	↓	↓	↓	↓	↓	↓	↓	↓	↓	↓			
Tdeg			↓	↓	2	↓	1	2	↓	↓	↓	↓	↓	↓	↓	↓	↓	↓	↓	↓	↓	↓			
Tdeh			↓	↓	2	↓	2	2	2	↓	1	1	1	1	1	1	1	1	1	1	1	↓			
Tdra			Reverbe	500kHz	↓	↓	1	↓	1	1	1	↓	2	2	2	2	2	2	1	1	2	2		↓	
Tdrb		↓			↓	↓	↓	↓	↓	↓	↓	↓	↓	↓	↓	↓	2	2	2	2	1	1		↓	
Tdrc		↓			↓	↓	↓	↓	↓	↓	↓	↓	↓	↓	↓	↓	2	2	1	1	↓	2		2	
Tdrd		↓			↓	↓	↓	↓	↓	↓	↓	↓	2	2	1	2	2	↓	↓	↓	↓	↓		↓	
Tdre		↓		↓	↓	↓	↓	↓	↓	1	↓	1	1	2	↓	↓	2	2	↓	↓	↓	↓			
Tdrf		↓		↓	↓	↓	↓	↓	↓	2	↓	2	2	↓	↓	↓	↓	1	1	2	2	↓			
Tdrg		↓		↓	↓	↓	↓	↓	↓	↓	↓	↓	↓	↓	↓	2	2	2	2	1	1	↓			
Tdrh		↓		↓	↓	↓	↓	↓	↓	↓	↓	↓	2	2	1	1	↓	↓	2	2	↓	↓			
Tdri		↓	↓	↓	↓	↓	↓	↓	↓	↓	2	2	1	2	2	↓	↓	↓	↓	↓	↓				
Tdrj	↓	↓	1	2	1	1	2	↓	1	1	2	2	2	2	2	2	2	2	2	↓					



DIGITAL REVERBE (DIGITAL DELAY)

Switching setting (Cont.)

※...See the under the table. \*...1 or 2

Symbol	Parameter	Mode	Sampling frequency	S02	S08	S10	S11	S12	S13	S14	S15	S16	S17	S18	S19	S22	S23	S24	S25	S26	S27	S40	Remark		
V <sub>omaxs</sub>	Maximum output voltage	Surround	1MHz	↓	↓	2	1	*	*	*	↓	↓	↓	↓	1	1	1	1	1	1	1	1	↓	30kHz L.P.F THD = 10 % In the reverbe mode, measurement is made for individual demodulators.	
V <sub>omaxe1</sub>		Echo	500kHz	↓	↓	2	2	*	*	1	↓	↓	↓	↓	↓	↓	↓	↓	↓	↓	↓	↓	↓		
V <sub>omaxe2</sub>		Echo	250kHz	↓	↓	2	2	*	*	2	1	1	1	1	1	1	1	1	1	1	1	1	↓		
V <sub>omaxr1</sub>		Reverbe	500kHz	↓	↓	1	2	1	1	1	↓	※	※	※	※	※	※	※	※	※	※	※	※		↓
V <sub>omaxr2</sub>			250kHz	1	1	1	2	1	1	2	1	※	※	※	※	※	※	※	※	※	※	※	※		1
THDs	Higher harmonic distortion	Surround	1MHz	1	1	2	1	*	*	*	1	1	1	1	1	1	1	1	1	1	1	1	↓	30kHz L.P.F In the reverbe mode, measurement is made for individual demodulators.	
THDe1		Echo	500kHz	↓	↓	2	2	*	*	1	↓	↓	↓	↓	↓	↓	↓	↓	↓	↓	↓	↓	↓		
THDe2		Echo	250kHz	↓	↓	2	2	*	*	2	↓	↓	↓	1	1	1	1	1	1	1	1	1	↓		
THDr1		Reverbe	500kHz	↓	↓	1	2	1	1	1	↓	↓	↓	※	※	※	※	※	※	※	※	※	※		↓
THDr2			250kHz	↓	↓	1	2	1	1	2	↓	↓	↓	※	※	※	※	※	※	※	※	※	※		1
Nos	Output noise voltage	Surround	1MHz	↓	↓	2	1	*	*	*	↓	↓	↓	↓	1	1	1	1	1	1	1	1	2	DIN AUDIO V <sub>i</sub> = 0mVrms	
Noe1		Echo	500kHz	↓	↓	2	2	*	*	1	↓	↓	↓	↓	↓	↓	↓	↓	↓	↓	↓	↓	↓		
Noe2		Echo	250kHz	↓	↓	2	2	*	*	2	↓	↓	↓	↓	↓	↓	↓	↓	↓	↓	↓	↓	↓		
Nor1		Reverbe	500kHz	↓	↓	1	2	1	1	1	↓	↓	↓	↓	↓	↓	↓	↓	↓	↓	↓	↓	↓		↓
Nor2			250kHz	↓	↓	1	2	1	1	2	↓	↓	↓	↓	↓	↓	↓	↓	↓	↓	↓	↓	↓		2
SVRR	Supply voltage reduction ratio	Surround/echo/reverbe		↓	↓	*	*	*	*	↓	↓	↓	↓	↓	↓	↓	↓	↓	↓	↓	↓	↓	1	ΔV <sub>cc</sub> =-20dBV, f=100Hz	
MUTEs	Muting time	Surround	1MHz	↓	↓	2	1	2	2	↓	1	↓	↓	↓	↓	↓	↓	↓	↓	↓	↓	↓	↓		
MUTEe		Echo	500kHz	↓	↓	2	2	2	2	↓	2	↓	↓	↓	↓	↓	↓	↓	↓	↓	↓	↓	↓		↓
		Echo	250kHz	↓	↓	2	2	2	2	↓	2	↓	↓	↓	↓	↓	↓	↓	↓	↓	↓	↓	↓		↓
MUTEr		Reverbe	500kHz	1	1	1	2	1	1	2	↓	1	1	1	1	1	1	1	1	1	1	1	1		↓
		Reverbe	250kHz	1	1	1	2	1	1	2	↓	1	1	1	1	1	1	1	1	1	1	1	1	↓	

Note. ※ indicates that measurement is made for individual demodulators in the reverbe mode.

For demodulator 2 (DEM2), measurement is made with the following switch setting. Use equivalent switch setting for measuring each of other demodulators 1 through 5.

S	S	S	S	S	S	S	S	S	S
16	17	18	19	22	23	24	25	26	27
2	2	2	2	2	2	2	2	1	1

DIGITAL REVERBE (DIGITAL DELAY)

TYPICAL CHARACTERISTICS

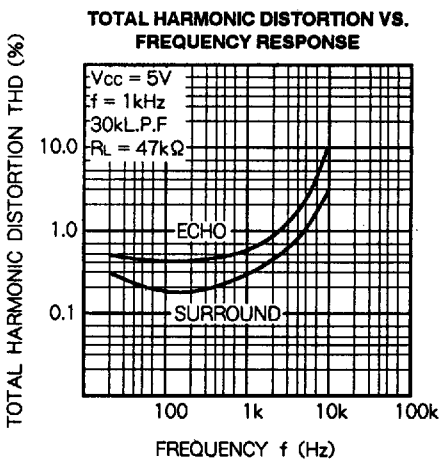
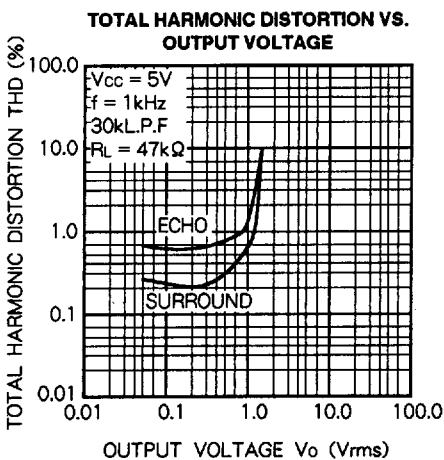
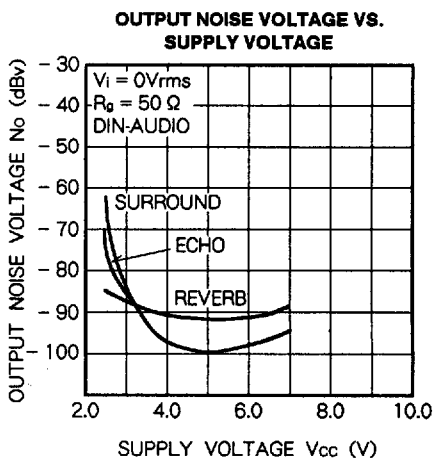
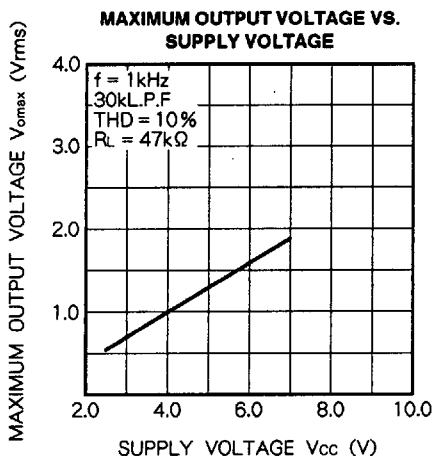
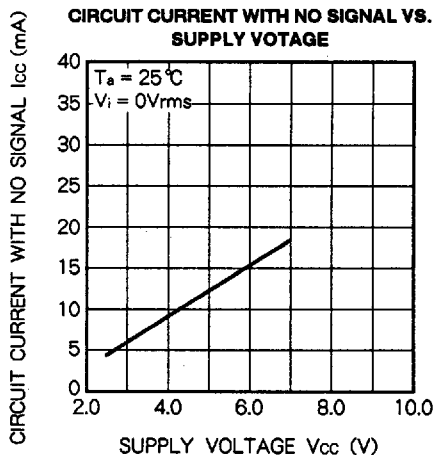
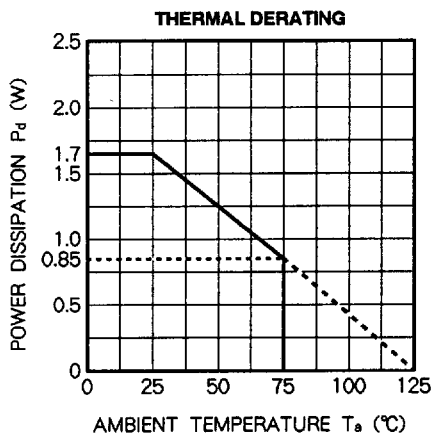

DIGITAL REVERBE (DIGITAL DELAY)

APPLICATION EXAMPLE

Easy mode 1ch. OUT

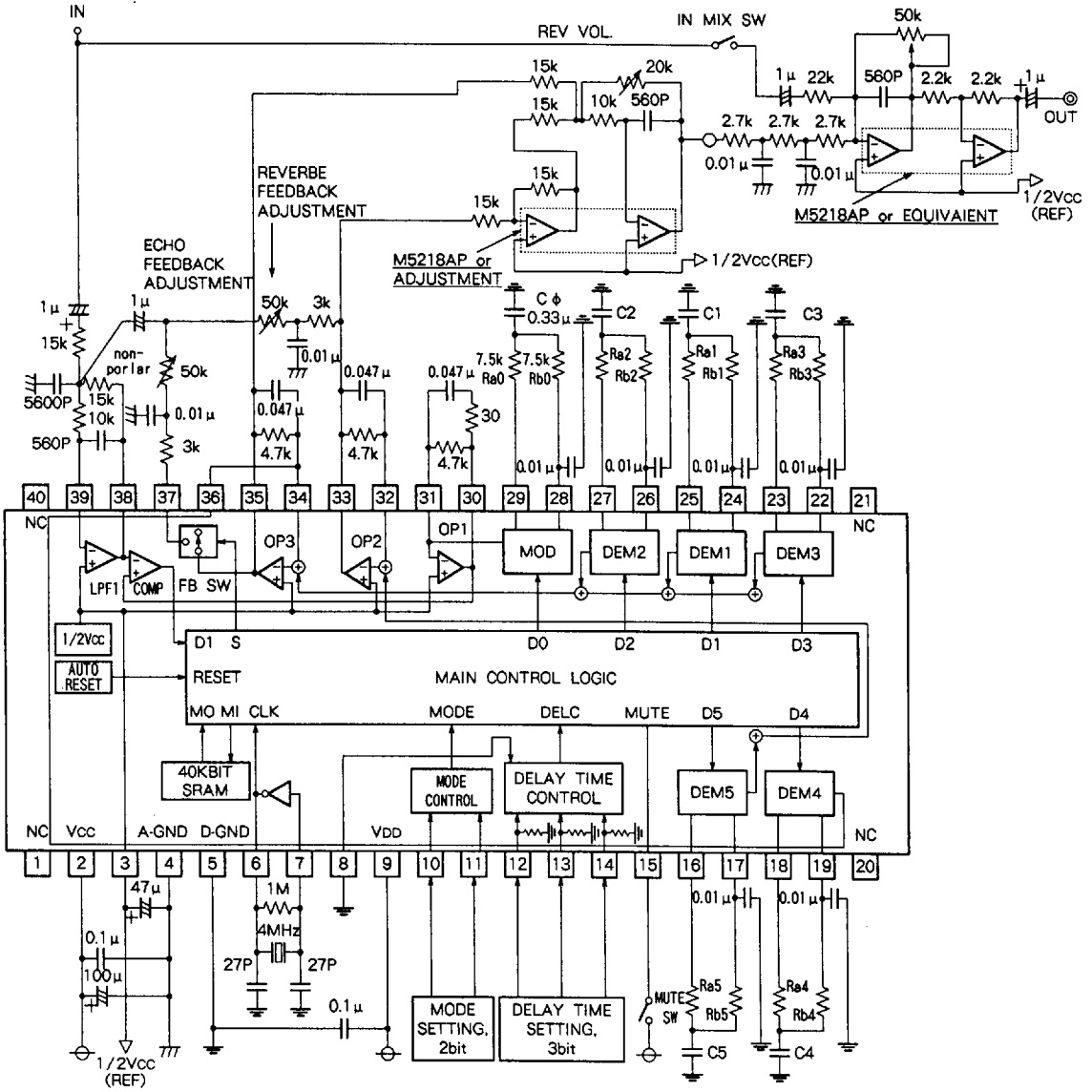

⏏ DIGITAL GND  
 ⏏ ANALOG GND

Units Resistance : Ω  
 Capacitance : F

APPLICATION EXAMPLE

Easy mode 2ch. OUT

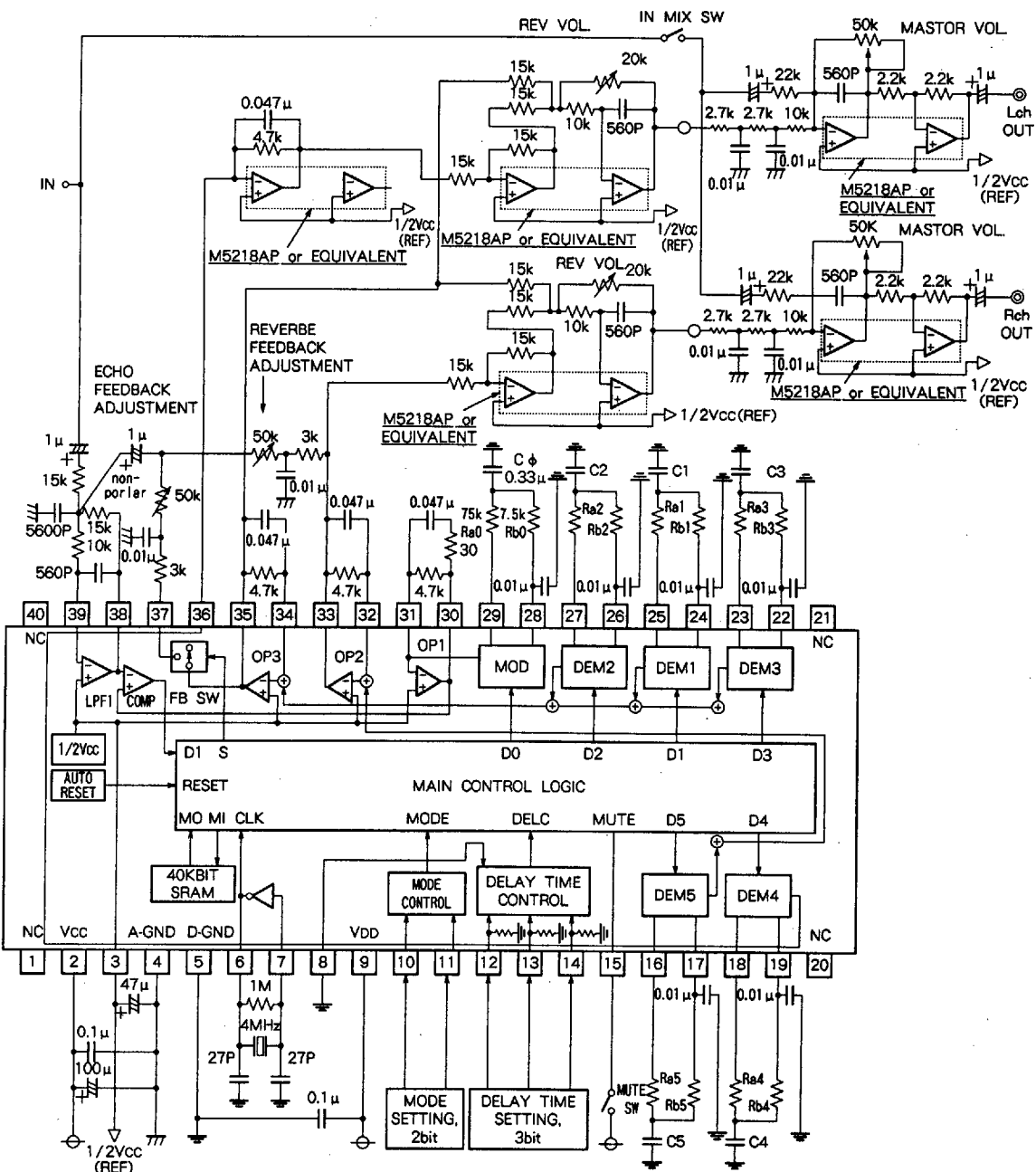

DIGITAL GND  
 ANALOG GND  
 Units Resistance : Ω  
 Capacitance : F

6249826 0022091 451

