

Battery Disconnect Switch

FEATURES

- 6- to 18-V Operation
- Separate Logic Voltage Input
- Undervoltage Lockout (UVL) @ $V_L = 3\text{ V}$
- Shutdown Control Capability
- Safe Power Down

DESCRIPTION

The Si9717 is a reverse blocking switch for battery disconnect applications. It is an integrated solution for multiple battery technology designs or designs that require isolation from the power bus during charging. The Si9717 is available in a 16-pin SOIC package and is rated for the commercial temperature range of 0 to 70°C.

The Si9717 is available in both standard and lead (Pb)-free packages.

FUNCTIONAL BLOCK DIAGRAM

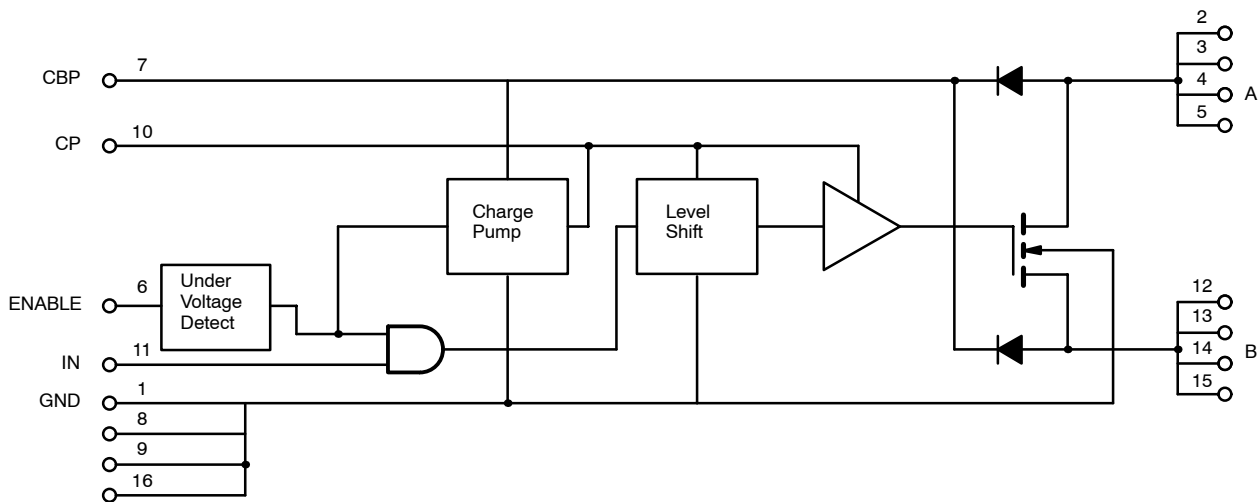

ABSOLUTE MAXIMUM RATINGS

Voltage Referenced to GND

V_A, V_B	-0.3 to 20 V
V_{IN}	-0.3 to 10 V
V_{ENABLE}	-0.3 to 10 V

Storage Temperature	-65 to 125°C
Power Dissipation	2 W

Notes: Device mounted with all leads soldered to PC board.

RECOMMENDED OPERATING RANGE

V_A, V_B (see note)	6 to 18 V
V_{IN}	0 to 5 V
I_{AB} (continuous)	0 to 4 A
$I_{AB} \times V_A$ (continuous)	0 to 40 W
Minimum Cycle Time (turn-on to turn-on)	10 ms
V_{ENABLE}	0 to 5 V

Operating Temperature	0 to 70°C
Junction Temperature	0 to 150°C

Notes:

- a. is functional at $V_A, V_B = 5$ to 6 V with higher supply current. See $I_{A(on)}$ specification.

SPECIFICATIONS							
Parameter	Symbol	Test Conditions Unless Otherwise Specified $6\text{ V} \leq V_A \leq 18\text{ V}$ $C_{VDD} = 0.1\ \mu\text{F}$, $C_P = 0.02\ \mu\text{F}$	Temp ^a	Limits ^d			Unit
				Min ^b	Typ ^c	Max ^b	
On-Resistance	R_{AB}	$V_A = 10\text{ V}$, $I_A = 1\text{ A}$	Room			0.06	Ω
Leakage Current	$I_{AB(\text{off})}$	$V_A = 16\text{ V}$, $V_B = 0\text{ V}$	Room			10	μA
IN Low Threshold	$V_{IN(L)}$		Full			1	V
IN High Threshold	$V_{IN(H)}$		Full	4.0			
IN Input Current	$I_{IN(H)}$	$V_{IN} = 5.0\text{ V}$	Full			1	μA
Turn-On Delay IN to A or B	$t_{ON(IN)}$	ENABLE = 5 V, $V_A = 10\text{ V}$, $R_L = 5\ \Omega$ Test Circuit 1	Full			10	μs
Turn-Off Delay IN to A or B	$t_{OFF(IN)}$		Full			10	
ENABLE Low Threshold	$V_{ENABLE(L)}$		Full			3.0	V
ENABLE High Threshold	$V_{ENABLE(H)}$		Full	4.4			
ENABLE Input Current	$I_{ENABLE(H)}$	$V_{ENABLE} = 5\text{ V}$	Full			50	μA
Setup Time from ENABLE to Switch	$t_{ENABLE(H)}$	$V_A = 10\text{ V}$, $V_{IN} = 0\text{ V}$, Test Circuit 2	Room			2.0	ms
		$V_A = 6\text{ V}$, $V_{IN} = 0\text{ V}$, Test Circuit 2	Full			10	
On-State Drain	$I_{A(\text{on})}$	AB Shorted, $V_A = 10\text{ V}$, $V_{ENABLE} = 5\text{ V}$	Full			60	μA
		AB Shorted, $V_A = 5\text{ V}$, $V_{ENABLE} = 5\text{ V}$	Full			300	
Off-State Drain	$I_{A(\text{off})}$	AB Shorted, $V_A = 10\text{ V}$, $V_{ENABLE} = 0\text{ V}$	Full			10	

Notes:

- Room = 25°C, Full = as determined by the operating temperature suffix.
- The algebraic convention whereby the most negative value is a minimum and the most positive a maximum, is used in this data sheet.
- Typical values are for DESIGN AID ONLY, not guaranteed nor subject to production testing.
- Tested at room temperature, high temperature guaranteed by statistical data correlation techniques.

TEST CIRCUITS

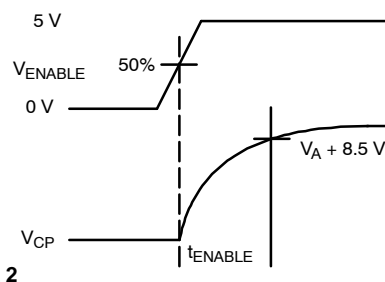
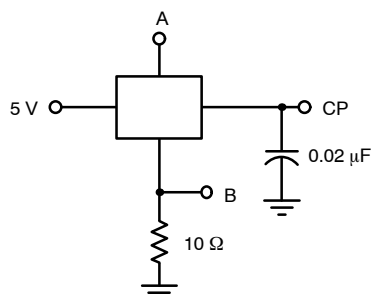
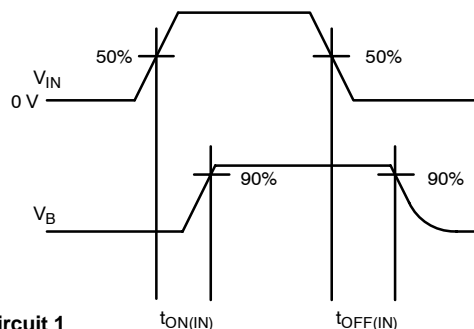
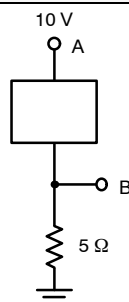

PIN CONFIGURATION, TRUTH TABLE AND ORDERING INFORMATION

TRUTH TABLE			
ENABLE	IN	Switch Controller State	Switch
0	0	Inactive	X
0	1	Inactive	X
1	0	Set-Up	Off
1	1	Active	On

ORDERING INFORMATION		
Part Number	Temperature Range	Package
Si9717CY	0 to 70°C	SOIC-16
Si9717CY-T1		
Si9717CY-T1—E3		

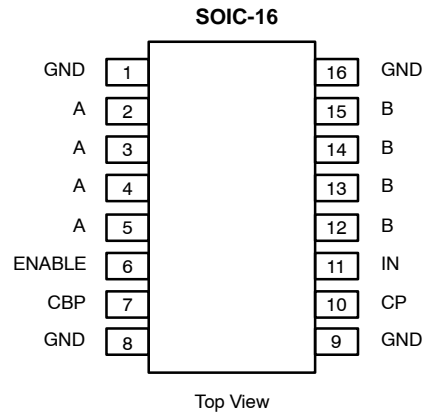

PIN DESCRIPTION

Pin Number	Symbol	Description
1, 8, 9, 16	GND	Common connection for negative battery terminals.
2, 3, 4, 5	A	A-terminal of the battery switch, bidirectional.
6	ENABLE	Logic input, ENABLE. Activates charge pump and switch drive logic.
7	CBP	Internally generated logic power supply, V_{DD} . Requires external bypass capacitor connected to pin 8.
10	CP	Charge pump output terminal. Requires external capacitor connected to pin 9.
11	IN	Logic input, IN. A high level turns on the switch.
12, 13, 14, 15	B	B-terminal of the battery switch, bidirectional.

APPLICATION DIAGRAM

