

50mA CMOS LDO WITH SHUTDOWN AND ERROR OUTPUT

FEATURES

- Zero Ground Current for Longer Battery Life
- Very Low Dropout Voltage
- Guaranteed 50mA Output
- High Output Voltage Accuracy
- Standard or Custom Output Voltages
- Power-Saving Shutdown Mode
- ERROR Output can be Used as a Low Battery Detector, or Processor Reset Generator
- Over-Current and Over-Temperature Protection
- Space-Saving SOT-23A-5 Package
- Pin Compatible Upgrades for Bipolar Regulators

APPLICATIONS

- Battery Operated Systems
- Portable Computers
- Medical Instruments
- Instrumentation
- Cellular/GSMS/PHS Phones
- Linear Post-Regulators for SMPS
- Pagers

ORDERING INFORMATION

Part No.	Output Voltage ^{**} (V)	Package	Junction Temp. Range
TC1054-2.5VCT	2.5	SOT-23A-5*	-40°C to +125°C
TC1054-2.7VCT	2.7	SOT-23A-5*	-40°C to +125°C
TC1054-3.0VCT	3.0	SOT-23A-5*	-40°C to +125°C
TC1054-3.3VCT	3.3	SOT-23A-5*	-40°C to +125°C
TC1054-5.0VCT	5.0	SOT-23A-5*	-40°C to +125°C

NOTE: *SOT-23A-5 is equivalent to the EIAJ (SC-74A)

** Other output voltages available. Please contact TelCom Semiconductor for details

PIN CONFIGURATION

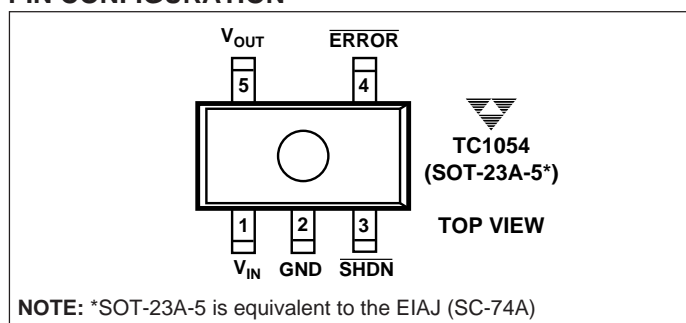

GENERAL DESCRIPTION

The TC1054 is a high accuracy (typically $\pm 0.5\%$) CMOS upgrade for older (bipolar) low dropout regulators. Designed specifically for battery-operated systems, the TC1054's CMOS construction eliminates wasted ground current, significantly extending battery life. Total supply current is typically $50\mu\text{A}$ at full load (*20 to 60 times lower than in bipolar regulators!*).

TC1054 key features include ultra low noise operation, very low dropout voltage (typically 100mV at full load) and internal feed-forward compensation for fast response to step changes in load. An error output (ERROR) is asserted when the TC1054 is out-of-regulation (due to a low input voltage or excessive output current). ERROR can be used as a low battery warning or as a processor RESET signal (with the addition of an external RC network). Supply current is reduced to less than $1\mu\text{A}$, and both V_{OUT} and ERROR are disabled when the shutdown input is low. The TC1054 incorporates both over-temperature and over-current protection.

The TC1054 is stable with an output capacitor of only $1\mu\text{F}$ and has a maximum output current of 50mA . For higher output current regulators, please see the TC1055 ($I_{\text{OUT}} = 100\text{mA}$) regulator and TC1107, TC1108 ($I_{\text{OUT}} = 300\text{mA}$) data sheets.

TYPICAL APPLICATION

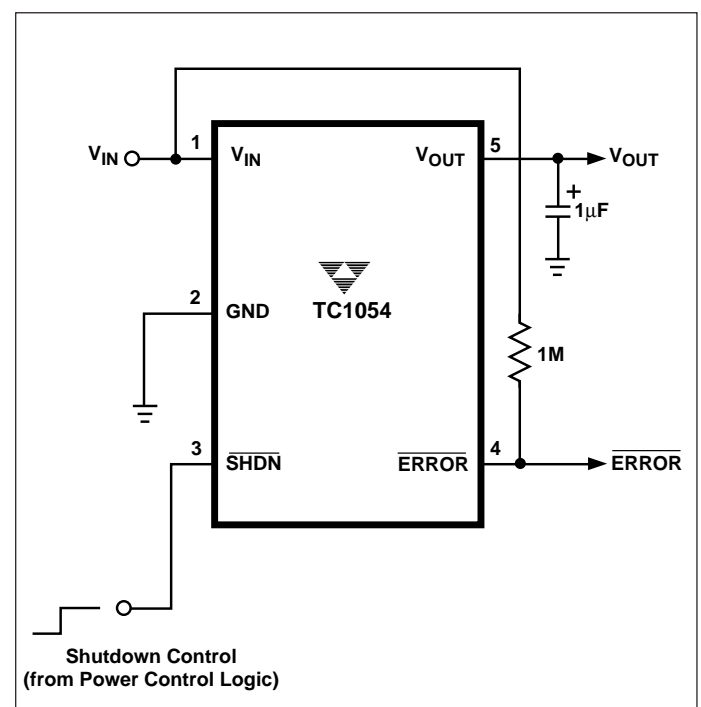

TC1054

ABSOLUTE MAXIMUM RATINGS*

Input Voltage	7V
Output Voltage	(- 0.3V) to (V _{IN} + 0.3V)
Power Dissipation	Internally Limited (Note 7)
Operating Temperature Range	- 40°C < T _J < 125°C
Storage Temperature	- 65°C to +150°C
Maximum Voltage on Any Pin	V _{IN} +0.3V to - 0.3V
Lead Temperature (Soldering, 10 Sec.)	+260°C

*Stresses above those listed under "Absolute Maximum Ratings" may cause permanent damage to the device. These are stress ratings only and functional operation of the device at these or any other conditions above those indicated in the operation sections of the specifications is not implied. Exposure to Absolute Maximum Rating conditions for extended periods may affect device reliability.

ELECTRICAL CHARACTERISTICS: V_{IN} = V_{OUT} + 1V, I_L = 0.1mA, C_L = 3.3μF, $\overline{\text{SHDN}} > V_{IH}$, T_A = 25°C, unless otherwise noted.
BOLDFACE type specifications apply for junction temperatures of - 40°C to +125°C.

Symbol	Parameter	Test Conditions	Min	Typ	Max	Units
V _{IN}	Input Operating Voltage		—	—	6.5	V
I _{OUTMAX}	Maximum Output Current		50	—	—	mA
V _{OUT}	Output Voltage	Note 1	V_R - 2.5%	V _R ±0.5%	V_R + 2.5%	V
TC V _{OUT}	V _{OUT} Temperature Coefficient	Note 2	—	40	—	ppm/°C
ΔV _{OUT} /ΔV _{IN}	Line Regulation	(V _R + 1V) ≤ V _{IN} ≤ 6V	—	0.01	0.05	%/V
ΔV _{OUT} /V _{OUT}	Load Regulation	I _L = 0.1mA to I _{OUTMAX} (Note 3)	—	0.5	—	%
V _{IN} - V _{OUT}	Dropout Voltage	I _L = 0.1mA I _L = 20mA I _L = 50mA (Note 4)	— — —	5 65 95	—	mV
I _{GND}	Ground Pin Current	I _L = I _{OUTMAX} , (Note 5)	—	0	—	μA
I _{IN}	Supply Current	$\overline{\text{SHDN}} = V_{IH}$, I _L = 0	—	50	—	μA
I _{INSD}	Shutdown Supply Current	$\overline{\text{SHDN}} = 0V$	—	—	0.05	μA
R _{OUT}	Output Resistance during Shutdown	$\overline{\text{SHDN}} < V_{IL}$	100 x V _R	160 x V _R	—	kΩ
PSRR	Power Supply Rejection Ratio	F _{RE} ≤ 1kHz	—	64	—	dB
I _{OUTSC}	Output Short Circuit Current	V _{OUT} = 0V	—	200	450	mA
ΔV _{OUT} /ΔP _D	Thermal Regulation	Note 6	—	0.04	—	%/W
T _{SD}	Thermal Shutdown Die Temperature		—	160	—	°C
ΔT _{SD}	Thermal Shutdown Hysteresis		—	10	—	°C
eN	Output Noise	I _L = I _{OUTMAX}	—	160	—	μV
SHDN Input						
V _{IH}	$\overline{\text{SHDN}}$ Input High Threshold	V _{IN} = 2.5V to 6.5V	45	—	—	%V _{IN}
V _{IL}	$\overline{\text{SHDN}}$ Input Low Threshold	V _{IN} = 2.5V to 6.5V	—	—	15	%V _{IN}

ELECTRICAL CHARACTERISTICS: $V_{IN} = V_{OUT} + 1V$, $I_L = 0.1mA$, $C_L = 3.3\mu F$, $\overline{SHDN} > V_{IH}$, $T_A = 25^\circ C$, unless otherwise noted.

Symbol	Parameter	Test Conditions	Min	Typ	Max	Units
ERROR Output						
V_{MIN}	Minimum Operating Voltage		1.0	—	—	V
V_{OL}	Output Logic Low Voltage	1mA Flows to \overline{ERROR}	—	—	400	mV
V_{TH}	\overline{ERROR} Threshold Voltage	See Figure 2	—	$0.95 \times V_R$	—	V
V_{HYS}	\overline{ERROR} Positive Hysteresis	Note 8	—	50	—	mV

NOTES: 1. V_R is the regulator output voltage setting. $V_R = 2.5V, 2.7V, 3.0V, 3.3V, 5.0V$.

2. TC $V_{OUT} = \frac{V_{OUTMAX} - V_{OUTMIN}}{V_{OUT} \times \Delta T} \times 10^6$

- Regulation is measured at a constant junction temperature using low duty cycle pulse testing. Load regulation is tested over a load range from 0.1mA to the maximum specified output current. Changes in output voltage due to heating effects are covered by the thermal regulation specification.
- Dropout voltage is defined as the input to output differential at which the output voltage drops 2% below its nominal value.
- Ground pin current is the regulator pass transistor gate current. The total current drawn from the input supply is the sum of the load current, ground current and supply current (i.e. $I_{IN} = I_{SUPPLY} + I_{GND} + I_{LOAD}$).
- Thermal Regulation is defined as the change in output voltage at a time T after a change in power dissipation is applied, excluding load or line regulation effects. Specifications are for a current pulse equal to I_{LMAX} at $V_{IN} = 6V$ for $T = 10msec$.
- The maximum allowable power dissipation is a function of ambient temperature, the maximum allowable junction temperature and the thermal resistance from junction-to-air (i.e. T_A, T_J, q_{JA}). Exceeding the maximum allowable power dissipation causes the device to initiate thermal shutdown. Please see *Thermal Considerations* section of this data sheet for more details.
- Hysteresis voltage is referenced by V_R .

PIN DESCRIPTION

Pin No. (SOT-23A-5)	Symbol	Description
1	V_{IN}	Unregulated supply input.
2	GND	Ground terminal.
3	\overline{SHDN}	Shutdown control input. The regulator is fully enabled when a logic high is applied to this input. The regulator enters shutdown when a logic low is applied to this input. During shutdown, output voltage falls to zero, \overline{ERROR} is open circuited and supply current is reduced to 0.05 microamp (typical).
4	\overline{ERROR}	Out-of-Regulation Flag. (Open drain output). This output goes low when V_{OUT} is out-of-tolerance by approximately – 5%.
5	V_{OUT}	Regulated voltage output.

TC1054

DETAILED DESCRIPTION

The TC1054 is a precision fixed output voltage regulator. (If an adjustable version is desired, please see the TC1070 or TC1071 data sheets.) Unlike the bipolar regulators, the TC1054 supply current does not increase with load current. In addition, V_{OUT} remains stable and within regulation at very low load currents (an important consideration in RTC and CMOS RAM battery back-up applications).

Figure 1 shows a typical application circuit. The regulator is enabled any time the shutdown input (SHDN) is at or above V_{IH} , and shutdown (disabled) when SHDN is at or below V_{IL} . SHDN may be controlled by a CMOS logic gate, or I/O port of a microcontroller. If the SHDN input is not required, it should be connected directly to the input supply. While in shutdown, supply current decreases to $0.05\mu\text{A}$ (typical) and V_{OUT} falls to zero volts and ERROR is open circuited.

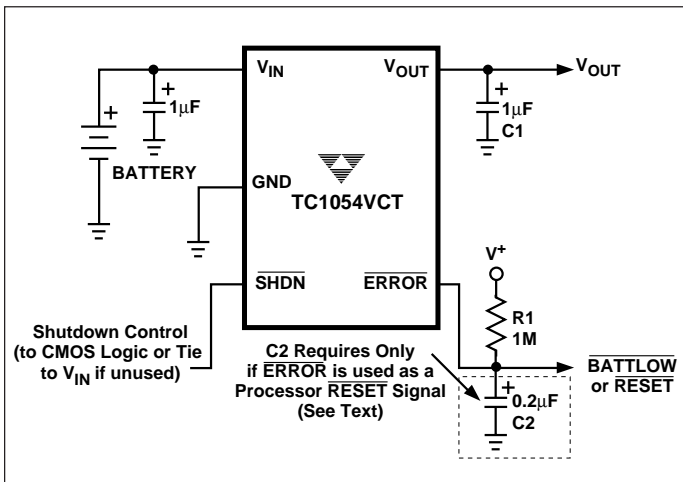

Figure 1. Typical Application Circuit

ERROR Open Drain Output

ERROR is driven low whenever V_{OUT} falls out of regulation by more than -5% (typical). This condition may be caused by low input voltage, output current limiting, or thermal limiting. The ERROR threshold is 5% below rated V_{OUT} regardless of the programmed output voltage value (e.g. ERROR = V_{OL} at 4.75 (typ.) for a 5.0V regulator and 2.85V (typ.) for a 3.0V regulator). ERROR output operation is shown in Figure 2.

Note that ERROR is active when V_{OUT} falls to V_{TH} , and inactive when V_{OUT} rises above $V_{TH} + V_{HYS}$.

As shown in Figure 1, ERROR can be used as a battery low flag, or as a processor RESET signal (with the addition of timing capacitor C2). $R1 \times C2$ should be chosen to maintain ERROR below V_{IH} of the processor RESET input for at least 200msec to allow time for the system to stabilize.

Pull-up resistor R1 can be tied to V_{OUT} , V_{IN} or any other voltage less than ($V_{IN} = 0.3V$).

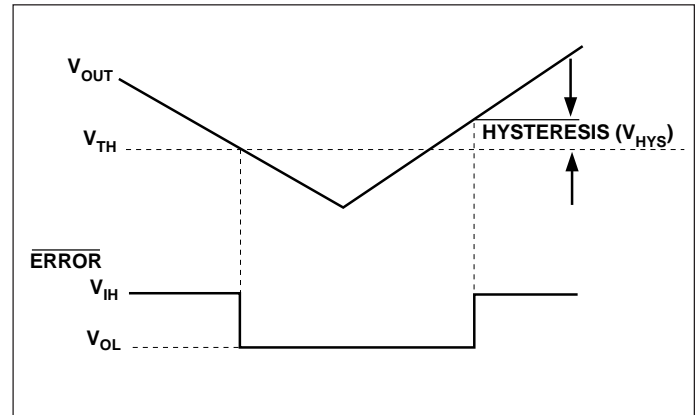

Figure 2. ERROR Output Operation

Output Capacitor

A $1\mu\text{F}$ (min) capacitor from V_{OUT} to ground is recommended. The output capacitor should have an effective series resistance of 5Ω or less, and a resonant frequency above 1MHz. A $1\mu\text{F}$ capacitor should be connected from V_{IN} to GND if there is more than 10 inches of wire between the regulator and the AC filter capacitor, or if a battery is used as the power source. Aluminum electrolytic or tantalum capacitor types can be used. (Since many aluminum electrolytic capacitors freeze at approximately -30°C , solid tantalums are recommended for applications operating below -25°C .) When operating from sources other than batteries, supply-noise rejection and transient response can be improved by increasing the value of the input and output capacitors and employing passive filtering techniques.

Thermal Considerations

Thermal Shutdown

Integrated thermal protection circuitry shuts the regulator off when die temperature exceeds 160°C . The regulator remains off until the die temperature drops to approximately 150°C .

Power Dissipation

The amount of power the regulator dissipates is primarily a function of input and output voltage, and output current. The following equation is used to calculate worst case actual power dissipation:

$$P_D \approx (V_{IN_{MAX}} - V_{OUT_{MIN}})I_{LOAD_{MAX}}$$

Where:

P_D = Worst case actual power dissipation

$V_{IN_{MAX}}$ = Maximum voltage on V_{IN}

$V_{OUT_{MIN}}$ = Minimum regulator output voltage

$I_{LOAD_{MAX}}$ = Maximum output (load) current

Equation 1.

The maximum *allowable* power dissipation (Equation 2) is a function of the maximum ambient temperature (T_{AMAX}), the maximum allowable die temperature (125°C) and the thermal resistance from junction-to-air (θ_{JA}). SOT-23A-5 package has a θ_{JA} of approximately 220°C/Watt when mounted on a single layer FR4 dielectric copper clad PC board.

$$P_{D_{MAX}} = \frac{(T_{J_{MAX}} - T_{A_{MAX}})}{\theta_{JA}}$$

Where all terms are previously defined.

Equation 2.

Equation 1 can be used in conjunction with Equation 2 to ensure regulator thermal operation is within limits. For example:

Given:

$$V_{IN_{MAX}} = 3.0V \pm 5\%$$

$$V_{OUT_{MIN}} = 2.7V \pm 0.5V$$

$$I_{LOAD} = 40mA$$

$$T_{AMAX} = 55^\circ C$$

- Find:
1. Actual power dissipation
 2. Maximum allowable dissipation

Actual power dissipation:

$$\begin{aligned} P_D &\approx (V_{IN_{MAX}} - V_{OUT_{MIN}})I_{LOAD_{MAX}} \\ &= [(3.0 \times 1.05) - (2.7 \times .995)]40 \times 10^{-3} \\ &= 18.5mW \end{aligned}$$

Maximum allowable power dissipation:

$$\begin{aligned} P_{D_{MAX}} &= \frac{(T_{J_{MAX}} - T_{A_{MAX}})}{\theta_{JA}} \\ &= \frac{(125 - 55)}{220} \\ &= 318mW \end{aligned}$$

In this example, the TC1054 dissipates a maximum of only 18.5mW; far below the allowable limit of 318mW. In a similar manner, Equation 1 and Equation 2 can be used to calculate maximum current and/or input voltage limits.

Layout Considerations

The primary path of heat conduction out of the package is via the package leads. Therefore, layouts having a ground plane, wide traces at the pads, and wide power supply bus lines combine to lower θ_{JA} and therefore increase the maximum allowable power dissipation limit.

TC1054

MARKINGS

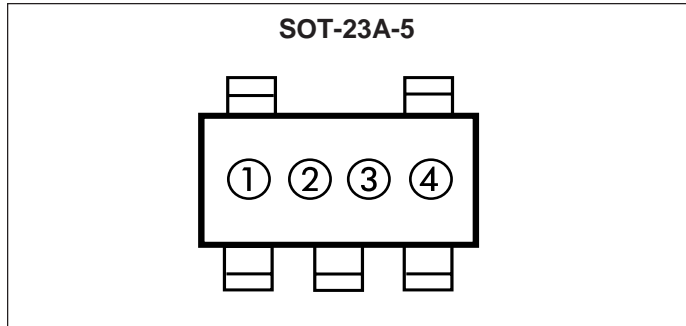

① & ② = part number code + temperature range and voltage

TC1054 (V)	Code
2.5	C1
2.7	C2
3.0	C3
3.3	C4
5.0	C6

③ represents year and quarter code

④ represents lot ID number

PACKAGE DIMENSIONS

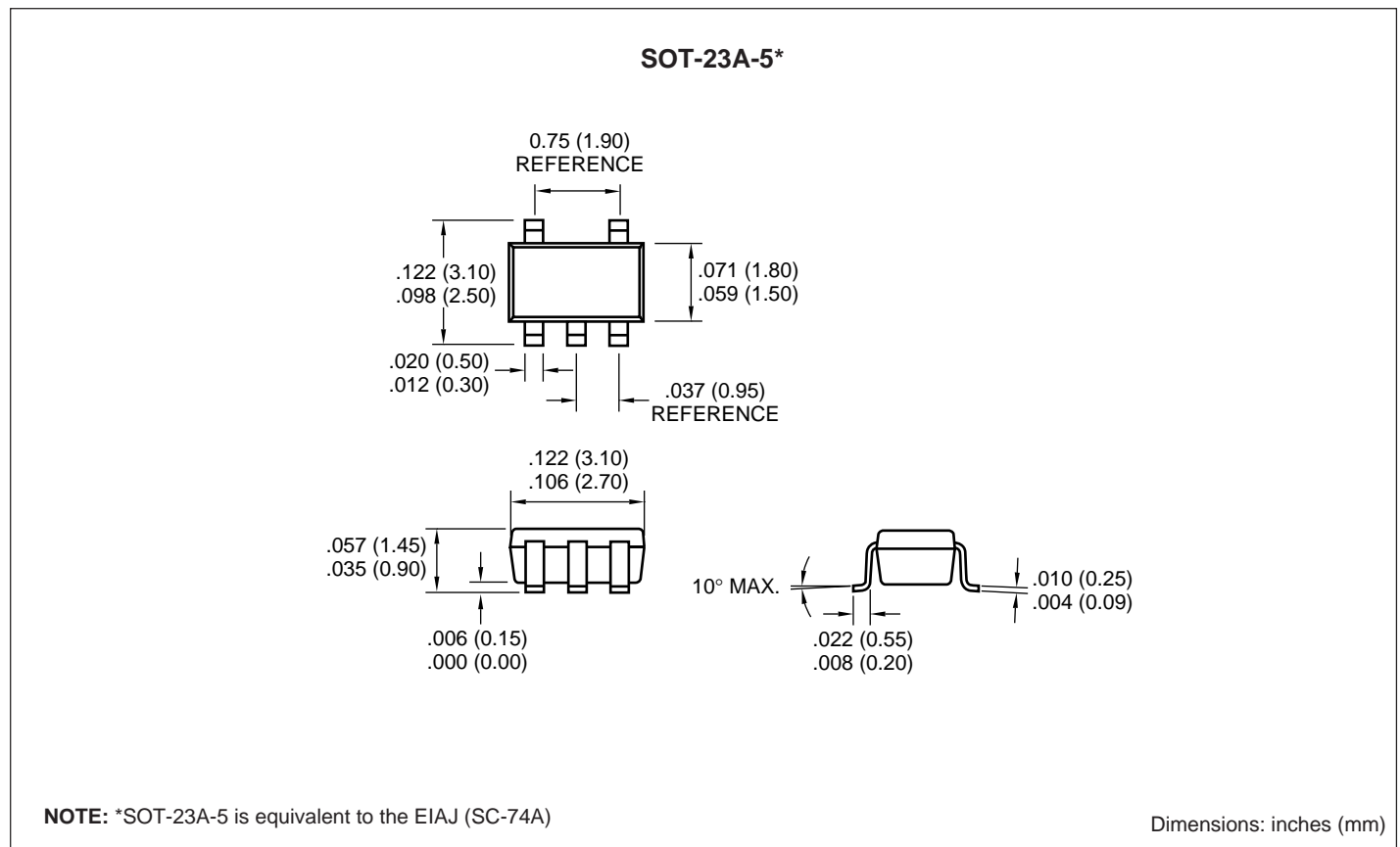

Sales Offices

TelCom Semiconductor
1300 Terra Bella Avenue
P.O. Box 7267
Mountain View, CA 94039-7267
TEL: 415-968-9241
FAX: 415-967-1590
E-Mail: liter@c2smtp.telcom-semi.com

TelCom Semiconductor
Austin Product Center
9101 Burnet Rd. Suite 214
Austin, TX 78758
TEL: 512-873-7100
FAX: 512-873-8236

TelCom Semiconductor H.K. Ltd.
10 Sam Chuk Street, Ground Floor
San Po Kong, Kowloon
Hong Kong
TEL: 852-2324-0122
FAX: 852-2354-9957

100mA CMOS LDO WITH SHUTDOWN AND ERROR OUTPUT

FEATURES

- Zero Ground Current for Longer Battery Life
- Very Low Dropout Voltage
- Guaranteed 100mA Output
- High Output Voltage Accuracy
- Standard or Custom Output Voltages
- Power-Saving Shutdown Mode
- ERROR Output can be Used as a Low Battery Detector, or Processor Reset Generator
- Over-Current and Over-Temperature Protection
- Space-Saving SOT-23A-5 Package
- Pin Compatible Upgrades for Bipolar Regulators

APPLICATIONS

- Battery Operated Systems
- Portable Computers
- Medical Instruments
- Instrumentation
- Cellular/GSMS/PHS Phones
- Linear Post-Regulators for SMPS
- Pagers

ORDERING INFORMATION

Part No.	Output Voltage ** (V)	Package	Junction Temp. Range
TC1055-2.5VCT	2.5	SOT-23A-5*	-40°C to +125°C
TC1055-2.7VCT	2.7	SOT-23A-5*	-40°C to +125°C
TC1055-3.0VCT	3.0	SOT-23A-5*	-40°C to +125°C
TC1055-3.3VCT	3.3	SOT-23A-5*	-40°C to +125°C
TC1055-5.0VCT	5.0	SOT-23A-5*	-40°C to +125°C

NOTE: *SOT-23A-5 is equivalent to the EIAJ (SC-74A)
 ** Other output voltages available. Please contact TelCom Semiconductor for details

PIN CONFIGURATION

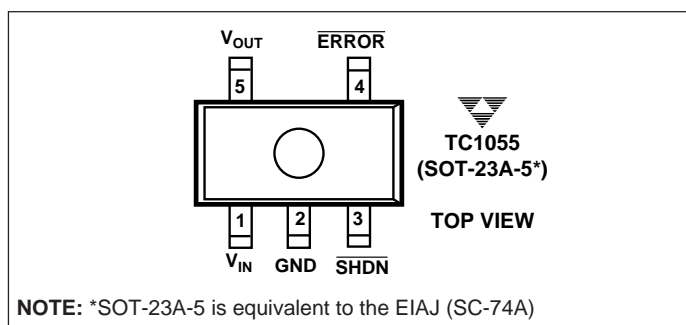

GENERAL DESCRIPTION

The TC1055 is a high accuracy (typically $\pm 0.5\%$) CMOS upgrade for older (bipolar) low dropout regulators. Designed specifically for battery-operated systems, the TC1055's CMOS construction eliminates wasted ground current, significantly extending battery life. Total supply current is typically $50\mu\text{A}$ at full load (*20 to 60 times lower than in bipolar regulators!*).

TC1055 key features include ultra low noise operation, very low dropout voltage (typically 200mV at full load) and internal feed-forward compensation for fast response to step changes in load. An error output (ERROR) is asserted when the TC1055 is out-of-regulation (due to a low input voltage or excessive output current). ERROR can be used as a low battery warning or as a processor RESET signal (with the addition of an external RC network). Supply current is reduced to less than $1\mu\text{A}$, and both V_{OUT} and ERROR are disabled when the shutdown input is low. The TC1055 incorporates both over-temperature and over-current protection.

The TC1055 is stable with an output capacitor of only $1\mu\text{F}$ and has a maximum output current of 100mA. For higher output current regulators, please see the TC1107, TC1108 ($I_{\text{OUT}} = 300\text{mA}$) data sheets.

TYPICAL APPLICATION

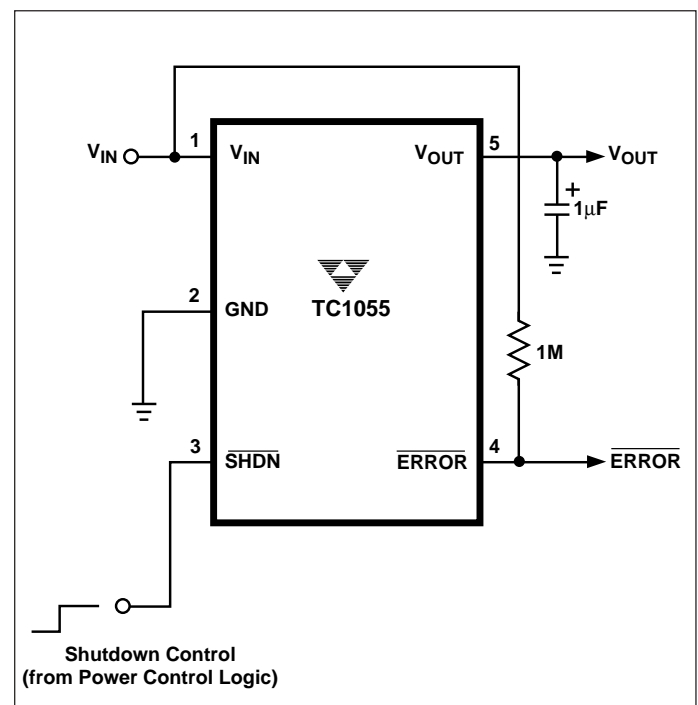

TC1055

ABSOLUTE MAXIMUM RATINGS*

Input Voltage	7V
Output Voltage	(- 0.3V) to (V _{IN} + 0.3V)
Power Dissipation	Internally Limited (Note 7)
Operating Temperature Range	- 40°C < T _J < 125°C
Storage Temperature	- 65°C to +150°C
Maximum Voltage on Any Pin	V _{IN} + 0.3V to - 0.3V

*Stresses above those listed under "Absolute Maximum Ratings" may cause permanent damage to the device. These are stress ratings only and functional operation of the device at these or any other conditions above those indicated in the operation sections of the specifications is not implied. Exposure to Absolute Maximum Rating conditions for extended periods may affect device reliability.

ELECTRICAL CHARACTERISTICS: V_{IN} = V_{OUT} + 1V, I_L = 0.1mA, C_L = 3.3μF, $\overline{\text{SHDN}} > V_{IH}$, T_A = 25°C, unless otherwise noted.

Symbol	Parameter	Test Conditions	Min	Typ	Max	Units
V _{IN}	Input Operating Voltage	Note 9	—	—	6.5	V
I _{OUTMAX}	Maximum Output Current	Note 9	100	—	—	mA
V _{OUT}	Output Voltage	Notes 1, 9	V _R - 2.5%	V _R ± 0.5%	V _R + 2.5%	V
TC V _{OUT}	V _{OUT} Temperature Coefficient	Note 2, 9	—	20 40	—	ppm/°C
ΔV _{OUT} /ΔV _{IN}	Line Regulation	(V _R + 1V) ≤ V _{IN} ≤ 6V	—	0.05	—	%
ΔV _{OUT} /V _{OUT}	Load Regulation	I _L = 0.1mA to I _{OUTMAX} (Note 3)	—	0.5	—	%
V _{IN} - V _{OUT}	Dropout Voltage	I _L = 0.1mA I _L = 20mA I _L = 50mA I _L = 100mA (Note 4)	— — — —	20 70 100 200	—	mV
I _{GND}	Ground Pin Current	I _L = I _{OUTMAX} , (Note 5, 9)	—	0	—	μA
I _{IN}	Supply Current	$\overline{\text{SHDN}} = V_{IH}$, I _L = 0	—	50	80	μA
I _{INSD}	Shutdown Supply Current	$\overline{\text{SHDN}} = 0V$	—	—	0.05	μA
R _{OUT}	Output Resistance during Shutdown	$\overline{\text{SHDN}} < V_{IL}$	100 x V _R	160 x V _R	—	kΩ
PSRR	Power Supply Rejection Ratio	F _{RE} ≤ 1kHz	—	64	—	dB
I _{OUTSC}	Output Short Circuit Current	V _{OUT} = 0V	—	300	500	mA
ΔV _{OUT} /ΔP _D	Thermal Regulation	Note 6	—	0.04	—	%W
eN	Output Noise	I _L = I _{OUTMAX}	—	160	—	nV/√Hz

SHDN Input

V _{IH}	$\overline{\text{SHDN}}$ Input High Threshold	V _{IN} = 2.5V to 6.5V	45	—	—	%V _{IN}
V _{IL}	$\overline{\text{SHDN}}$ Input Low Threshold	V _{IN} = 2.5V to 6.5V	—	—	15	%V _{IN}

ELECTRICAL CHARACTERISTICS: $V_{IN} = V_{OUT} + 1V$, $I_L = 0.1\mu A$, $C_L = 3.3\mu F$, $\overline{SHDN} > V_{IH}$, $T_A = 25^\circ C$, unless otherwise noted.

Symbol	Parameter	Test Conditions	Min	Typ	Max	Units
ERROR Open Drain Output						
V_{MIN}	Minimum Operating Voltage		1.0	—	—	V
V_{OL}	Output Logic Low Voltage	1mA Flows to \overline{ERROR}	—	—	400	mV
V_{TH}	\overline{ERROR} Threshold Voltage	See Figure 2	—	$0.95 \times V_R$	—	V
V_{HYS}	\overline{ERROR} Positive Hysteresis	Note 8	—	50	—	mV

NOTES: 1. V_R is the regulator output voltage setting. $V_R = 2.5V, 2.7V, 3.0V, 3.3V, 5.0V$.

2. $TC V_{OUT} = \frac{(V_{OUTMAX} - V_{OUTMIN}) \times 10^6}{V_{OUT} \times \Delta T}$

- Regulation is measured at a constant junction temperature using low duty cycle pulse testing. Load regulation is tested over a load range from 0.1mA to the maximum specified output current. Changes in output voltage due to heating effects are covered by the thermal regulation specification.
- Dropout voltage is defined as the input to output differential at which the output voltage drops 2% below its nominal value.
- Ground pin current is the regulator pass transistor gate current. The total current drawn from the input supply is the sum of the load current, ground current and supply current (i.e. $I_{IN} = I_{SUPPLY} + I_{GND} + I_{LOAD}$).
- Thermal Regulation is defined as the change in output voltage at a time T after a change in power dissipation is applied, excluding load or line regulation effects. Specifications are for a current pulse equal to I_{LMAX} at $V_{IN} = 6V$ for $T = 10msec$.
- The maximum allowable power dissipation is a function of ambient temperature, the maximum allowable junction temperature and the thermal resistance from junction-to-air (i.e. T_A, T_J, q_{JA}). Exceeding the maximum allowable power dissipation causes the device to initiate thermal shutdown. Please see *Thermal Considerations* section of this data sheet for more details.
- Hysteresis voltage is referenced by V_R .
- Boldface type specifications apply for junction temperatures of $-40^\circ C$ to $+125^\circ C$.

PIN DESCRIPTION

Pin No. (SOT-23A-5)	Symbol	Description
1	V_{IN}	Unregulated supply input.
2	GND	Ground terminal.
3	\overline{SHDN}	Shutdown control input. The regulator is fully enabled when a logic high is applied to this input. The regulator enters shutdown when a logic low is applied to this input. During shutdown, output voltage falls to zero, \overline{ERROR} is open circuited and supply current is reduced to 0.05 microamp (typical).
4	\overline{ERROR}	Out-of-Regulation Flag. (Open drain output). This output goes low when V_{OUT} is out-of-tolerance by approximately -5% .
5	V_{OUT}	Regulated voltage output.

TC1055

DETAILED DESCRIPTION

The TC1055 is a precision fixed output voltage regulator. (If an adjustable version is desired, please see the TC1070 or TC1071 data sheets.) Unlike the bipolar regulators, the TC1055 supply current does not increase with load current. In addition, V_{OUT} remains stable and within regulation at very low load currents (an important consideration in RTC and CMOS RAM battery back-up applications).

Figure 1 shows a typical application circuit. The regulator is enabled any time the shutdown input (SHDN) is at or above V_{IH} , and shutdown (disabled) when SHDN is at or below V_{IL} . SHDN may be controlled by a CMOS logic gate, or I/O port of a microcontroller. If the SHDN input is not required, it should be connected directly to the input supply. While in shutdown, supply current decreases to $0.05\mu\text{A}$ (typical) and V_{OUT} falls to zero volts and ERROR is open circuited.

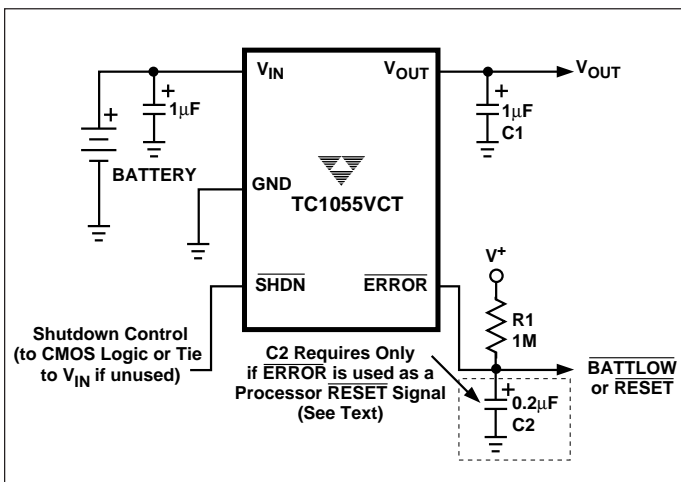

Figure 1. Typical Application Circuit

ERROR Open Drain Output

ERROR is driven low whenever V_{OUT} falls out of regulation by more than -5% (typical). This condition may be caused by low input voltage, output current limiting, or thermal limiting. The ERROR threshold is 5% below rated V_{OUT} regardless of the programmed output voltage value (e.g. $\text{ERROR} = V_{OL}$ at 4.75 (typ.) for a 5.0V regulator and 2.85V (typ.) for a 3.0V regulator). ERROR output operation is shown in Figure 2.

Note that ERROR is active when V_{OUT} falls to V_{TH} , and inactive when V_{OUT} rises above V_{TH} by V_{HYS} .

As shown in Figure 1, ERROR can be used as a battery low flag, or as a processor RESET signal (with the addition of timing capacitor C2). $R1 \times C2$ should be chosen to maintain ERROR below V_{IH} of the processor RESET input for at least 200msec to allow time for the system to stabilize.

Pull-up resistor R1 can be tied to V_{OUT} , V_{IN} or any other voltage less than $(V_{IN} + 0.3V)$.

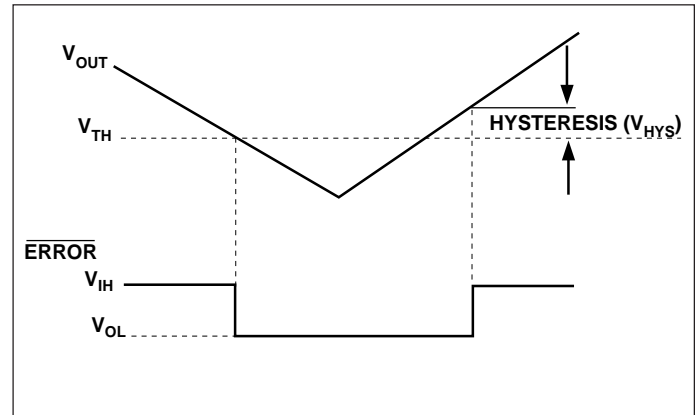

Figure 2. ERROR Output Operation

Output Capacitor

A $1\mu\text{F}$ (min) capacitor from V_{OUT} to ground is recommended. The output capacitor should have an effective series resistance of 5Ω or less, and a resonant frequency above 1MHz. A $1\mu\text{F}$ capacitor should be connected from V_{IN} to GND if there is more than 10 inches of wire between the regulator and the AC filter capacitor, or if a battery is used as the power source. Aluminum electrolytic or tantalum capacitor types can be used. (Since many aluminum electrolytic capacitors freeze at approximately -30°C , solid tantalums are recommended for applications operating below -25°C .) When operating from sources other than batteries, supply-noise rejection and transient response can be improved by increasing the value of the input and output capacitors and employing passive filtering techniques.

Thermal Considerations

Thermal Shutdown

Integrated thermal protection circuitry shuts the regulator off when die temperature exceeds 160°C . The regulator remains off until the die temperature drops to approximately 150°C .

Power Dissipation

The amount of power the regulator dissipates is primarily a function of input and output voltage, and output current. The following equation is used to calculate worst case actual power dissipation:

$$P_D \approx (V_{IN_{MAX}} - V_{OUT_{MIN}})I_{LOAD_{MAX}}$$

Where:

P_D = Worst case actual power dissipation

$V_{IN_{MAX}}$ = Maximum voltage on V_{IN}

$V_{OUT_{MIN}}$ = Minimum regulator output voltage

$I_{LOAD_{MAX}}$ = Maximum output (load) current

Equation 1.

The maximum *allowable* power dissipation (Equation 2) is a function of the maximum ambient temperature (T_{AMAX}), the maximum allowable die temperature (125°C) and the thermal resistance from junction-to-air (θ_{JA}). SOT-23A-5 package has a θ_{JA} of approximately 220°C/Watt when mounted on a single layer FR4 dielectric copper clad PC board.

$$P_{D_{MAX}} = \frac{(T_{J_{MAX}} - T_{A_{MAX}})}{\theta_{JA}}$$

Where all terms are previously defined.

Equation 2.

Equation 1 can be used in conjunction with Equation 2 to ensure regulator thermal operation is within limits. For example:

Given:

$$V_{IN_{MAX}} = 3.0V \pm 5\%$$

$$V_{OUT_{MIN}} = 2.7V \pm 0.5V$$

$$I_{LOAD} = 40mA$$

$$T_{AMAX} = 55^\circ C$$

- Find:
1. Actual power dissipation
 2. Maximum allowable dissipation

Actual power dissipation:

$$\begin{aligned} P_D &\approx (V_{IN_{MAX}} - V_{OUT_{MIN}})I_{LOAD_{MAX}} \\ &= [(3.0 \times 1.05) - (2.7 \times .995)]40 \times 10^{-3} \\ &= 18.5mW \end{aligned}$$

Maximum allowable power dissipation:

$$\begin{aligned} P_{D_{MAX}} &= \frac{(T_{J_{MAX}} - T_{A_{MAX}})}{\theta_{JA}} \\ &= \frac{(125 - 55)}{220} \\ &= 318mW \end{aligned}$$

In this example, the TC1055 dissipates a maximum of only 60mW; far below the allowable limit of 318mW. In a similar manner, Equation 1 and Equation 2 can be used to calculate maximum current and/or input voltage limits. For example, the maximum allowable V_{IN} is found by substituting the maximum allowable power dissipation of 318mW into Equation 1, from which $V_{IN_{MAX}} = 5.9V$.

Layout Considerations

The primary path of heat conduction out of the package is via the package leads. Therefore, layouts having a ground plane, wide traces at the pads, and wide power supply bus lines combine to lower θ_{JA} and therefore increase the maximum allowable power dissipation limit.

TC1055

MARKINGS

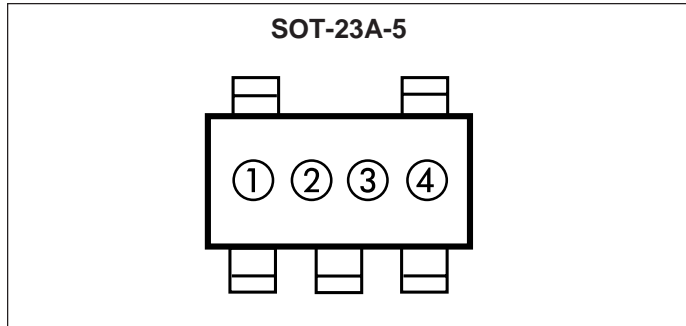

① & ② = part number code + temperature range and voltage

TC1055 (V)	Code
2.5	D1
2.7	D2
3.0	D3
3.3	D4
5.0	D6

③ represents year and quarter code

④ represents lot ID number

PACKAGE DIMENSIONS

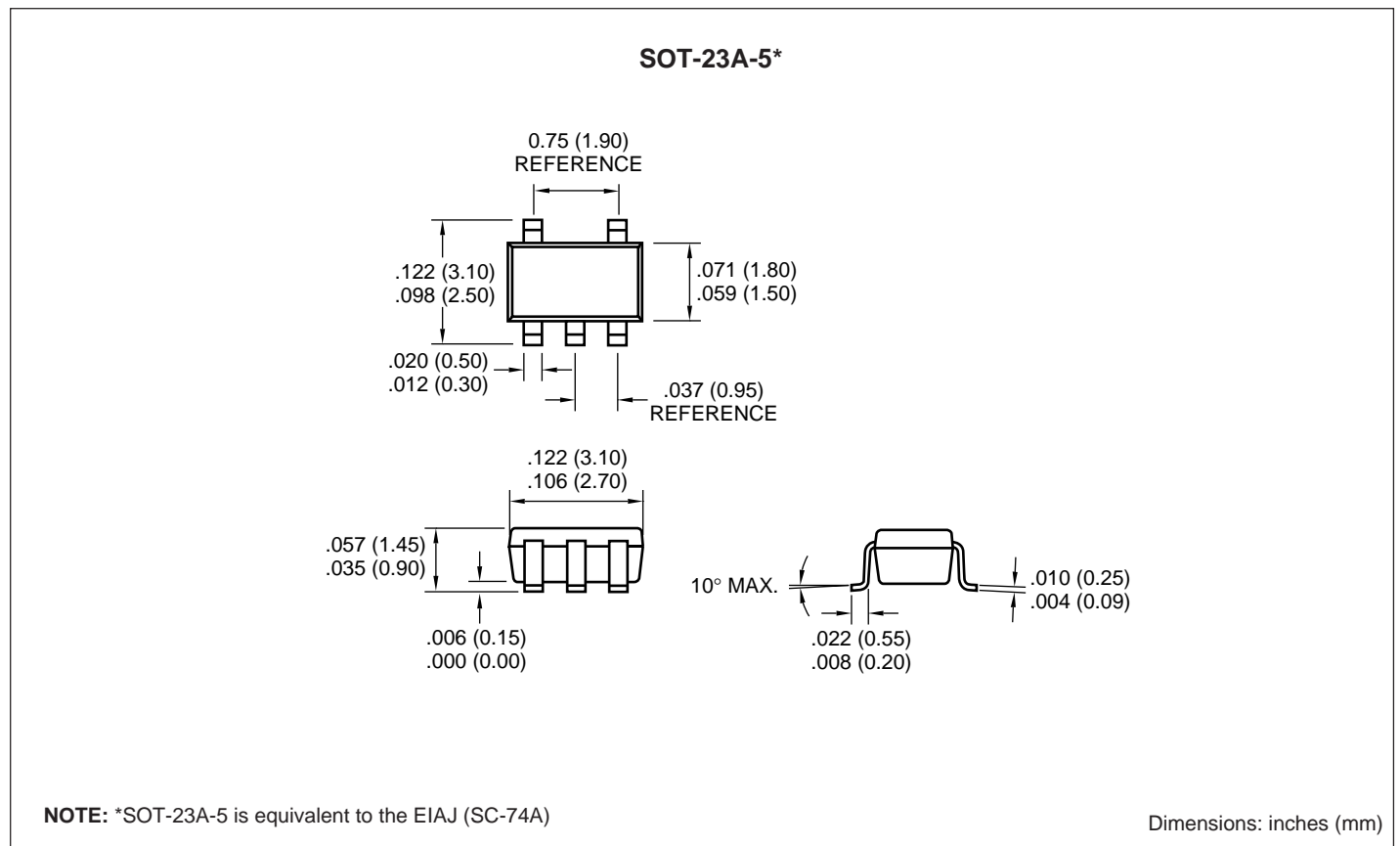

Sales Offices

TelCom Semiconductor
1300 Terra Bella Avenue
P.O. Box 7267
Mountain View, CA 94039-7267
TEL: 415-968-9241
FAX: 415-967-1590
E-Mail: liter@c2smtp.telcom-semi.com

TelCom Semiconductor
Austin Product Center
9101 Burnet Rd. Suite 214
Austin, TX 78758
TEL: 512-873-7100
FAX: 512-873-8236

TelCom Semiconductor H.K. Ltd.
10 Sam Chuk Street, Ground Floor
San Po Kong, Kowloon
Hong Kong
TEL: 852-2324-0122
FAX: 852-2354-9957