

PIN photodiode amplifier C4890

Wide bandwidth amplifier (1.5 GHz, 20 dB)



C4890 wide-band amplifier, when connected to a high-speed PIN photodiode (S5791, S5972, S5973, etc.) converts optical signals at a maximum of 1.5 GHz into voltage outputs with exceptionally low distortion and 20 dB gain.

C4890 can also be combined with other types of PIN photodiodes and APDs (avalanche photodiodes) to serve as a high-frequency amplifier for optical measurements in a wide range of fields including industry and research applications.

Features

- Wide bandwidth, high gain, flat gain spectrum
- Flat, low group delay characteristics and low noise
- Input/output impedance: 50 Ω
- Small size, light weight, low price
- Single power supply operation (+12 V)

Applications

- High frequency amplifier for measurement
- PIN photodiode evaluation

■ Absolute maximum ratings

| Parameter | Condition | Value | Unit |
|-----------------------|-----------------------|------------|--------------------|
| Supply voltage | | +13.5 | V |
| Input voltage | Continuation RF input | +15 | dBm |
| | DC | +1.25 | V |
| Operating temperature | | 0 to +60 | $^{\circ}\text{C}$ |
| Storage temperature | | -10 to +70 | $^{\circ}\text{C}$ |

■ Electrical characteristics (Ta=25 $^{\circ}\text{C}$, Vcc=12 V, Input/output is terminated with 50 Ω load.)

| Parameter | Condition | Min. | Typ. | Max. | Unit |
|---------------------------------|---------------------|------|-----------|------|------|
| Cut-off frequency (-3 dB) | High band | 1.0 | 1.5 | - | GHz |
| | Low band | - | 5 | 10 | MHz |
| Gain | f=1.0 GHz | 18 | 20 | - | dB |
| Gain deviation within bandwidth | f=10 MHz to 1.0 GHz | - | ± 1.0 | - | dB |
| Group delay time | | - | 700 | - | ps |
| VSWR | Input | - | 1.1 | - | dB |
| | Output | - | 1.5 | - | dB |
| 1 dB compression point | | - | 7 | - | dBm |
| Rise time | | - | 240 | - | ps |
| Noise figure | | - | 8 | - | dB |
| Current consumption | | - | 45 | - | mA |

■ Gain vs. frequency

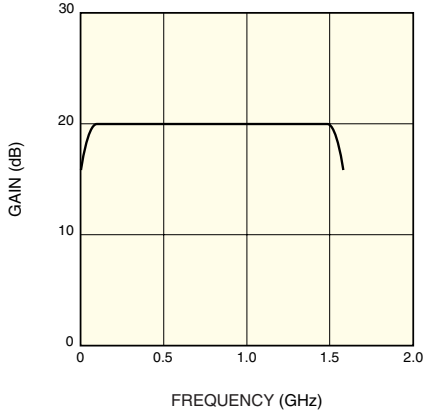

KACCB0038EA

■ Group delay time vs. frequency

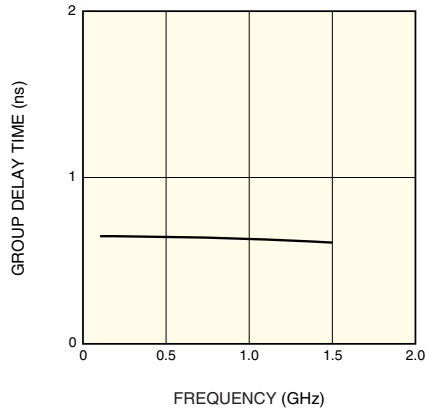

KACCB0039EA

■ Dimensional outline (unit: mm)

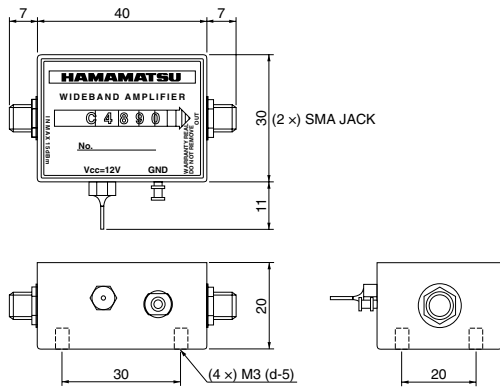

KACCA0034EA

■ Application example: High-speed O/E converter module

A high-sensitivity O/E converter can be easily configured by using C4890 in conjunction with a high-speed PIN photodiode (S5973, etc). The following is an example when C4890 is used with S5973 to amplify the output signal after receiving an attenuator. Major performance items are shown below.

Effective bandwidth: 5 MHz to 1.5 GHz

The lower limit is determined by the amplifier (C4890) and the upper limit by the photodiode.

$$\text{Conversion sensitivity (V/W)} = 0.5 \text{ A/W} \times 50 \times (100 - \alpha) / 100 \times 10 \text{ } (\lambda=850 \text{ nm})$$

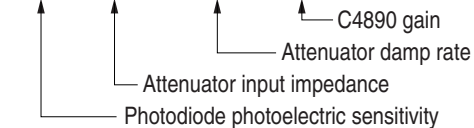

Detection limit: 4.4 μWrms (λ=850 nm, BW=1.5 GHz)

Depends on the amplifier NF (NF=8 dB Typ.).

■ Connection example

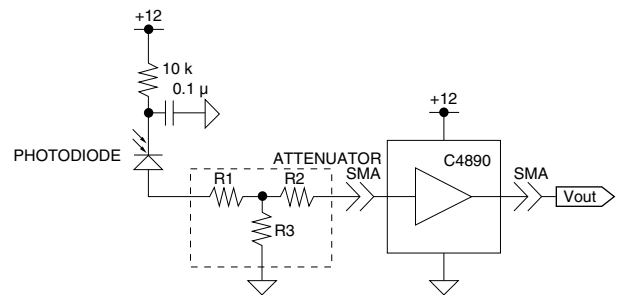

Resistance value according to the attenuator damp quantity

| Damp quantity (dB) | Damp rate (%) | R1, R2 (Ω) | R3 (Ω) |
|--------------------|---------------|------------|--------|
| 0 | 0 | 0 | 50 |
| 3 | 30 | 8.2 | 150 |
| 6 | 50 | 16 | 68 |
| 10 | 70 | 27 | 36 |

KPIN0003EB

The above specifications are typical values and not guaranteed.