

4K x 8/9 Dual-Port Static RAM

Features

- True Dual-Ported memory cells which allow simultaneous reads of the same memory location
- 4K x 8 organization (CY7C138)
- 4K x 9 organization (CY7C139)
- 0.65-micron CMOS for optimum speed/power
- High-speed access: 15 ns
- Low operating power: $I_{CC} = 160$ mA (max.)
- Fully asynchronous operation
- Automatic power-down
- TTL compatible
- Expandable data bus to 32/36 bits or more using Master/Slave chip select when using more than one device
- On-chip arbitration logic
- Semaphores included to permit software handshaking between ports
- \overline{INT} flag for port-to-port communication
- Available in 68-pin PLCC

Functional Description

The CY7C138 and CY7C139 are high-speed CMOS 4K x 8 and 4K x 9 dual-port static RAMs. Various arbitration schemes

are included on the CY7C138/9 to handle situations when multiple processors access the same piece of data. Two ports are provided permitting independent, asynchronous access for reads and writes to any location in memory. The CY7C138/9 can be utilized as a standalone 8/9-bit dual-port static RAM or multiple devices can be combined in order to function as a 16/18-bit or wider master/slave dual-port static RAM. An M/S pin is provided for implementing 16/18-bit or wider memory applications without the need for separate master and slave devices or additional discrete logic. Application areas include interprocessor/multiprocessor designs, communications status buffering, and dual-port video/graphics memory.

Each port has independent control pins: chip enable (\overline{CE}), read or write enable (\overline{RW}), and output enable (\overline{OE}). Two flags are provided on each port (\overline{BUSY} and \overline{INT}). \overline{BUSY} signals that the port is trying to access the same location currently being accessed by the other port. The interrupt flag (\overline{INT}) permits communication between ports or systems by means of a mail box. The semaphores are used to pass a flag, or token, from one port to the other to indicate that a shared resource is in use. The semaphore logic is comprised of eight shared latches. Only one side can control the latch (semaphore) at any time. Control of a semaphore indicates that a shared resource is in use. An automatic power-down feature is controlled independently on each port by a chip enable (\overline{CE}) pin or \overline{SEM} pin.

The CY7C138 and CY7C139 are available in a 68-pin PLCC.

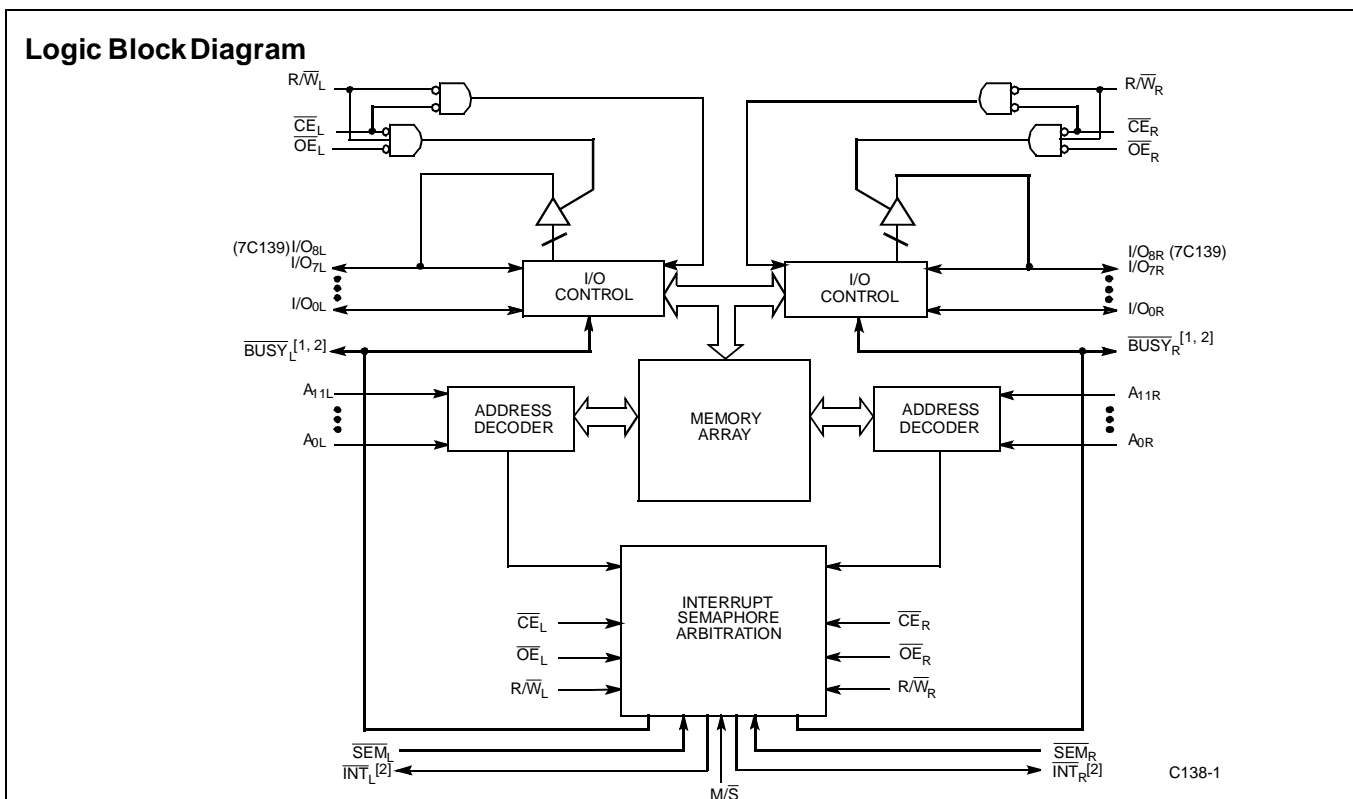

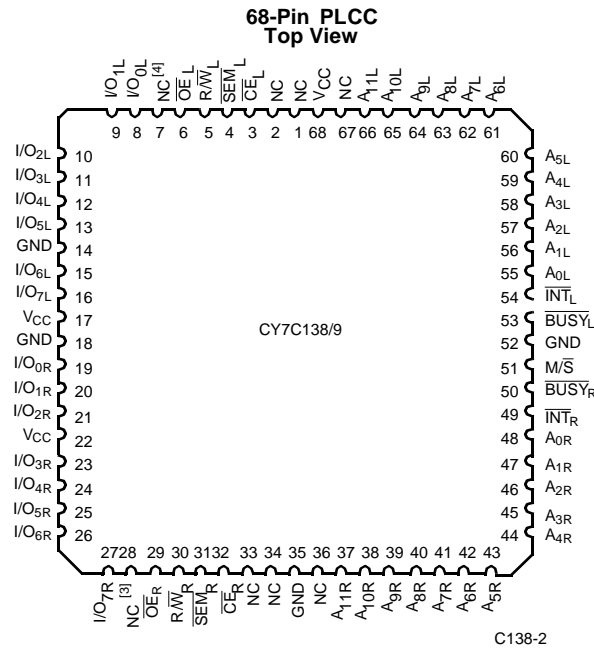
Pin Configurations

Notes:

3. I/O_{8R} on the CY7C139.
4. I/O_{8L} on the CY7C139.

Pin Definitions

Left Port	Right Port	Description
I/O _{0L-7L} (8L)	I/O _{0R-7R} (8R)	Data Bus Input/Output
A _{0L-11L}	A _{0R-11R}	Address Lines
\overline{CE}_L	\overline{CE}_R	Chip Enable
\overline{OE}_L	\overline{OE}_R	Output Enable
R/ \overline{W}_L	R/ \overline{W}_R	Read/Write Enable
\overline{SEM}_L	\overline{SEM}_R	Semaphore Enable. When asserted LOW, allows access to eight semaphores. The three least significant bits of the address lines will determine which semaphore to write or read. The I/O ₀ pin is used when writing to a semaphore. Semaphores are requested by writing a 0 into the respective location.
\overline{INT}_L	\overline{INT}_R	Interrupt Flag. \overline{INT}_L is set when right port writes location FFE and is cleared when left port reads location FFE. \overline{INT}_R is set when left port writes location FFF and is cleared when right port reads location FFF.
\overline{BUSY}_L	\overline{BUSY}_R	Busy Flag
M/S		Master or Slave Select
V _{CC}		Power
GND		Ground

Selection Guide

		7C138-15 7C139-15	7C138-25 7C139-25	7C138-35 7C139-35	7C138-55 7C139-55
Maximum Access Time (ns)		15	25	35	55
Maximum Operating Current (mA)	Commercial	220	180	160	160
Maximum Standby Current for I _{SB1} (mA)	Commercial	60	40	30	30

Maximum Ratings

(Above which the useful life may be impaired. For user guidelines, not tested.)

Storage Temperature -65°C to +150°C

Ambient Temperature with Power Applied -55°C to +125°C

Supply Voltage to Ground Potential -0.5V to +7.0V

DC Voltage Applied to Outputs in High Z State -0.5V to +7.0V

DC Input Voltage^[5] -0.5V to +7.0V

Output Current into Outputs (LOW) 20 mA

Static Discharge Voltage >2001V (per MIL-STD-883, Method 3015)

Latch-Up Current >200 mA

Operating Range

Range	Ambient Temperature	V _{CC}
Commercial	0°C to +70°C	5V ± 10%
Industrial	-40°C to +85°C	5V ± 10%

Electrical Characteristics Over the Operating Range

Parameter	Description	Test Conditions	7C138-15 7C139-15		7C138-25 7C139-25		Unit
			Min.	Max.	Min.	Max.	
V _{OH}	Output HIGH Voltage	V _{CC} = Min., I _{OH} = -4.0 mA	2.4		2.4		V
V _{OL}	Output LOW Voltage	V _{CC} = Min., I _{OL} = 4.0 mA		0.4		0.4	V
V _{IH}			2.2		2.2		V
V _{IL}	Input LOW Voltage			0.8		0.8	V
I _{Ix}	Input Leakage Current	GND ≤ V _I ≤ V _{CC}	-10	+10	-10	+10	μA
I _{OZ}	Output Leakage Current	Output Disabled, GND ≤ V _O ≤ V _{CC}	-10	+10	-10	+10	μA
I _{CC}	Operating Current	V _{CC} = Max., I _{OUT} = 0 mA, Outputs Disabled	Com'l	220	180		mA
			Ind		190		
I _{SB1}	Standby Current (Both Ports TTL Levels)	\overline{CE}_L and $\overline{CE}_R \geq V_{IH}$, f = f _{MAX} ^[6]	Com'l	60	40		mA
			Ind		50		
I _{SB2}	Standby Current (One Port TTL Level)	\overline{CE}_L and $\overline{CE}_R \geq V_{IH}$, f = f _{MAX} ^[6]	Com'l	130	110		mA
			Ind		120		
I _{SB3}	Standby Current (Both Ports CMOS Levels)	Both Ports CE and $\overline{CE}_R \geq V_{CC} - 0.2V$, V _{IN} ≥ V _{CC} - 0.2V or V _{IN} ≤ 0.2V, f = 0 ^[6]	Com'l	15	15		mA
			Ind		30		
I _{SB4}	Standby Current (One Port CMOS Level)	One Port \overline{CE}_L or $\overline{CE}_R \geq V_{CC} - 0.2V$, V _{IN} ≥ V _{CC} - 0.2V or V _{IN} ≤ 0.2V, Active Port Outputs, f = f _{MAX} ^[6]	Com'l	125	100		mA
			Ind		115		

Notes:

- Pulse width < 20 ns.
- f_{MAX} = 1/t_{RC} = All inputs cycling at f = 1/t_{RC} (except output enable). f = 0 means no address or control lines change. This applies only to inputs at CMOS level standby I_{SB3}.

Electrical Characteristics Over the Operating Range (continued)

Parameter	Description	Test Conditions	7C138-35 7C139-35		7C138-55 7C139-55		Unit	
			Min.	Max.	Min.	Max.		
V_{OH}	Output HIGH Voltage	$V_{CC} = \text{Min.}, I_{OH} = -4.0 \text{ mA}$	2.4		2.4		V	
V_{OL}	Output LOW Voltage	$V_{CC} = \text{Min.}, I_{OL} = 4.0 \text{ mA}$		0.4		0.4	V	
V_{IH}			2.2		2.2		V	
V_{IL}	Input LOW Voltage			0.8		0.8	V	
I_{IX}	Input Leakage Current	$GND \leq V_I \leq V_{CC}$	-10	+10	-10	+10	μA	
I_{OZ}	Output Leakage Current	Output Disabled, $GND \leq V_O \leq V_{CC}$	-10	+10	-10	+10	μA	
I_{CC}	Operating Current	$V_{CC} = \text{Max.},$ $I_{OUT} = 0 \text{ mA},$ Outputs Disabled	Com'l		160		160	mA
			Ind		180		180	
I_{SB1}	Standby Current (Both Ports TTL Levels)	\overline{CE}_L and $\overline{CE}_R \geq V_{IH},$ $f = f_{MAX}^{[6]}$	Com'l		30		30	mA
			Ind		40		40	
I_{SB2}	Standby Current (One Port TTL Level)	\overline{CE}_L and $\overline{CE}_R \geq V_{IH},$ $f = f_{MAX}^{[6]}$	Com'l		100		100	mA
			Ind		110		110	
I_{SB3}	Standby Current (Both Ports CMOS Levels)	Both Ports \overline{CE} and $\overline{CE}_R \geq V_{CC} - 0.2\text{V},$ $V_{IN} \geq V_{CC} - 0.2\text{V}$ or $V_{IN} \leq 0.2\text{V}, f = 0^{[6]}$	Com'l		15		15	mA
			Ind		30		30	
I_{SB4}	Standby Current (One Port CMOS Level)	One Port \overline{CE}_L or $\overline{CE}_R \geq V_{CC} - 0.2\text{V},$ $V_{IN} \geq V_{CC} - 0.2\text{V}$ or $V_{IN} \leq 0.2\text{V},$ Active Port Outputs, $f = f_{MAX}^{[6]}$	Com'l		90		90	mA
			Ind		100		100	

Capacitance^[7]

Parameter	Description	Test Conditions	Max.	Unit
C_{IN}	Input Capacitance	$T_A = 25^\circ\text{C}, f = 1 \text{ MHz},$ $V_{CC} = 5.0\text{V}$	10	pF
C_{OUT}	Output Capacitance		15	pF

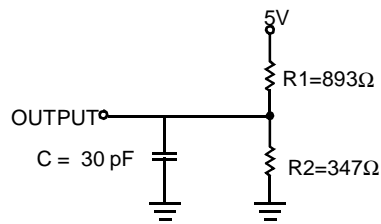
AC Test Loads and Waveforms

(a) Normal Load (Load 1)

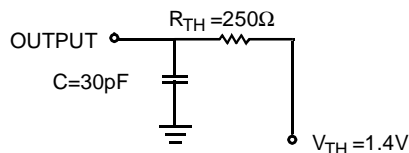
C138-3

(b) Thévenin Equivalent (Load 2)

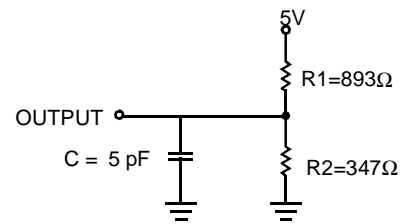
C138-4

(c) Three-State Delay (Load 3)

C138-5

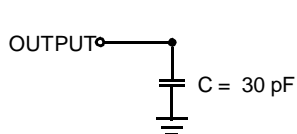
Load (Load 2)

C138-6

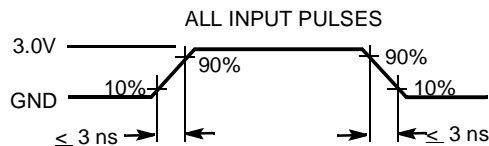

C138-7

Note:

7. Tested initially and after any design or process changes that may affect these parameters.

Switching Characteristics Over the Operating Range^[8]

Parameter	Description	7C138-15 7C139-15		7C138-25 7C139-25		7C138-35 7C139-35		7C138-55 7C139-55		Unit
		Min.	Max.	Min.	Max.	Min.	Max.	Min.	Max.	
READ CYCLE										
t_{RC}	Read Cycle Time	15		25		35		55		ns
t_{AA}	Address to Data Valid		15		25		35		55	ns
t_{OHA}	Output Hold From Address Change	3		3		3		3		ns
t_{ACE}	\overline{CE} LOW to Data Valid		15		25		35		55	ns
t_{DOE}	\overline{OE} LOW to Data Valid		10		15		20		25	ns
$t_{LZOE}^{[9,10,11]}$	\overline{OE} Low to Low Z	3		3		3		3		ns
$t_{HZOE}^{[9,10,11]}$	\overline{OE} HIGH to High Z		10		15		20		25	ns
$t_{LZCE}^{[9,10,11]}$	\overline{CE} LOW to Low Z	3		3		3		3		ns
$t_{HZCE}^{[9,10,11]}$	\overline{CE} HIGH to High Z		10		15		20		25	ns
$t_{PU}^{[11]}$	\overline{CE} LOW to Power-Up	0		0		0		0		ns
$t_{PD}^{[11]}$	\overline{CE} HIGH to Power-Down		15		25		35		55	ns
WRITE CYCLE										
t_{WC}	Write Cycle Time	15		25		35		55		ns
t_{SCE}	\overline{CE} LOW to Write End	12		20		30		40		ns
t_{AW}	Address Set-Up to Write End	12		20		30		40		ns
t_{HA}	Address Hold From Write End	2		2		2		2		ns
t_{SA}	Address Set-Up to Write Start	0		0		0		0		ns
t_{PWE}	Write Pulse Width	12		20		25		30		ns
t_{SD}	Data Set-Up to Write End	10		15		15		20		ns
t_{HD}	Data Hold From Write End	0		0		0		0		ns
$t_{HZWE}^{[10,11]}$	R/\overline{W} LOW to High Z		10		15		20		25	ns
$t_{LZWE}^{[10,11]}$	R/\overline{W} HIGH to Low Z	3		3		3		3		ns
$t_{WDD}^{[12]}$	Write Pulse to Data Delay		30		50		60		70	ns
$t_{DDD}^{[12]}$	Write Data Valid to Read Data Valid		25		30		35		40	ns
BUSY TIMING^[13]										
t_{BLA}	\overline{BUSY} LOW from Address Match		15		20		20		45	ns
t_{BHA}	\overline{BUSY} HIGH from Address Mismatch		15		20		20		40	ns
t_{BLC}	\overline{BUSY} LOW from \overline{CE} LOW		15		20		20		40	ns
t_{BHC}	\overline{BUSY} HIGH from \overline{CE} HIGH		15		20		20		35	ns
t_{PS}	Port Set-Up for Priority	5		5		5		5		ns
t_{WB}	R/\overline{W} LOW after \overline{BUSY} LOW	0		0		0		0		ns
t_{WH}	R/\overline{W} HIGH after \overline{BUSY} HIGH	13		20		30		40		ns
$t_{BDD}^{[14]}$	\overline{BUSY} HIGH to Data Valid		Note 14		Note 14		Note 14		Note 14	ns

8. Test conditions assume signal transition time of 3 ns or less, timing reference levels of 1.5V, input pulse levels of 0 to 3.0V, and output loading of the specified I_{OH}/I_{OH} and 30-pF load capacitance.

9. At any given temperature and voltage condition for any given device, t_{HZCE} is less than t_{LZCE} and t_{HZOE} is less than t_{LZOE} .

10. Test conditions used are Load 3.

11. This parameter is guaranteed but not tested.

12. For information on part-to-part delay through RAM cells from writing port to reading port, refer to Read Timing with Port-to-Port Delay waveform.

13. Test conditions used are Load 2.

14. t_{BDD} is a calculated parameter and is the greater of $t_{WDD} - t_{PWE}$ (actual) or $t_{DDD} - t_{SD}$ (actual).

Switching Characteristics Over the Operating Range^[8] (continued)

Parameter	Description	7C138-15 7C139-15		7C138-25 7C139-25		7C138-35 7C139-35		7C138-55 7C139-55		Unit
		Min.	Max.	Min.	Max.	Min.	Max.	Min.	Max.	
INTERRUPT TIMING^[13]										
t_{INS}	\overline{INT} Set Time		15		25		25		30	ns
t_{INR}	\overline{INT} Reset Time		15		25		25		30	ns
SEMAPHORE TIMING										
t_{SOP}	SEM Flag Update Pulse (\overline{OE} or \overline{SEM})	10		10		15		20		ns
t_{SWRD}	SEM Flag Write to Read Time	5		5		5		5		ns
t_{SPS}	SEM Flag Contention Window	5		5		5		5		ns

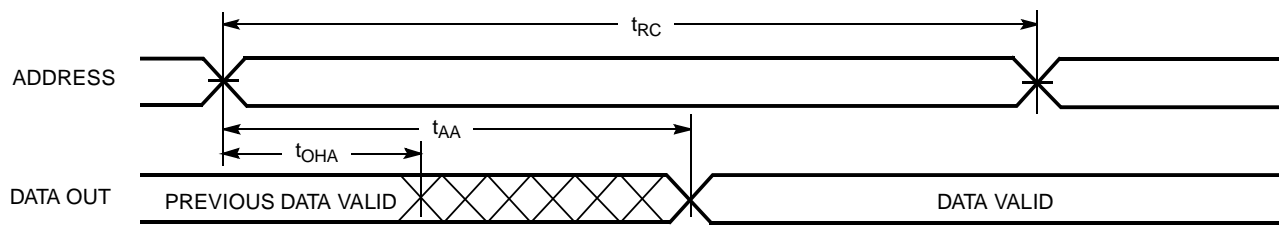
Switching Waveforms
Read Cycle No. 1 (Either Port Address Access)^[15, 16]

C138-8

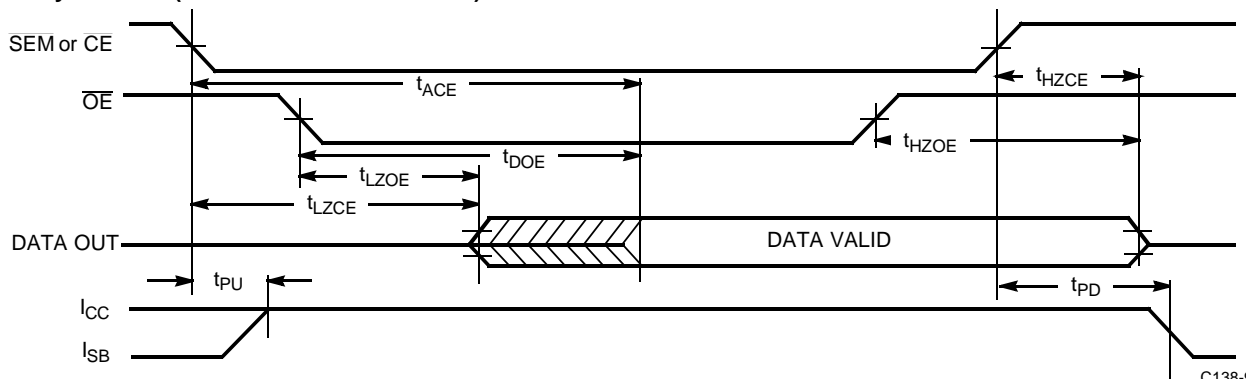
Read Cycle No. 2 (Either Port $\overline{CE}/\overline{OE}$ Access)^[15, 17, 18]

C138-9

Notes:

15. R/W is HIGH for read cycle.
16. Device is continuously selected $\overline{CE} = \text{LOW}$ and $\overline{OE} = \text{LOW}$. This waveform cannot be used for semaphore reads.
17. Address valid prior to or coincident with \overline{CE} transition LOW.
18. $\overline{CE}_L = \text{L}$, $\overline{SEM} = \text{H}$ when accessing RAM. $\overline{CE} = \text{H}$, $\overline{SEM} = \text{L}$ when accessing semaphores.

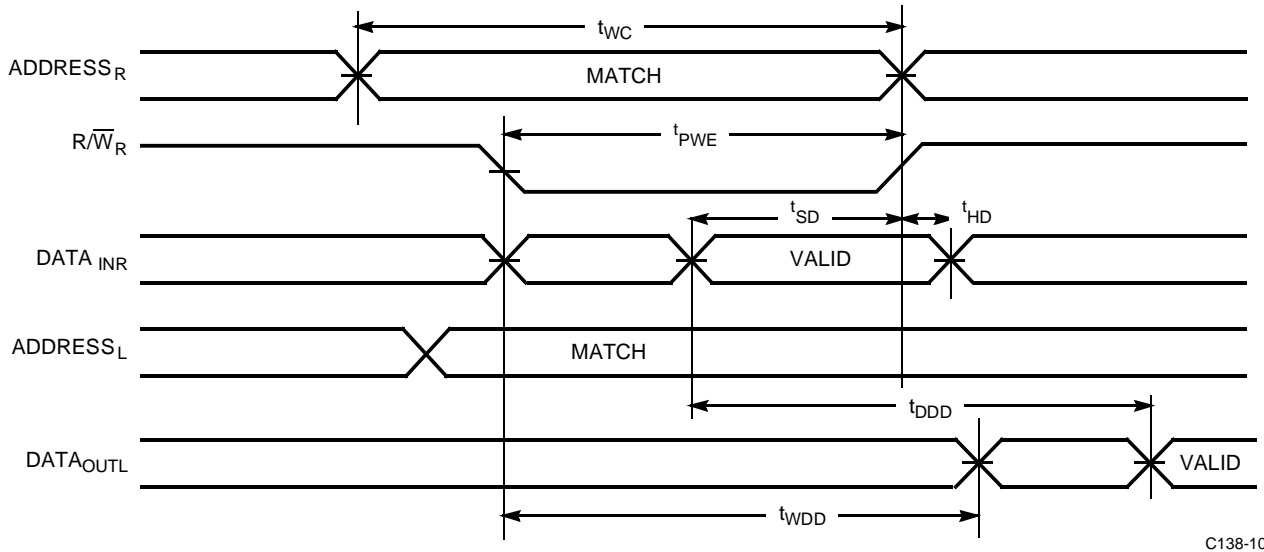
Switching Waveforms (continued)
Read Timing with Port-to-Port Delay ($M/\bar{S} = L$)^[19, 20]

C138-10

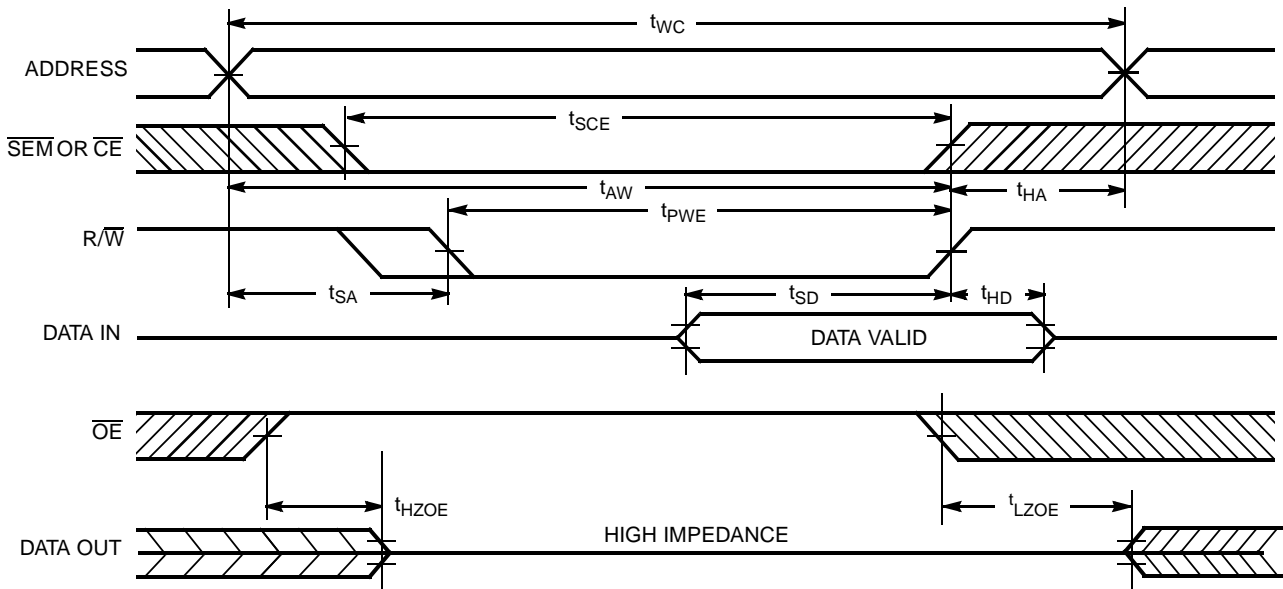
Write Cycle No. 1: OE Three-States Data I/Os (Either Port)^[21, 22, 23]

C138-11

Notes:

19. $\overline{BUSY} = \text{HIGH}$ for the writing port.
20. $\overline{CE}_L = \overline{CE}_R = \text{LOW}$.
21. The internal write time of the memory is defined by the overlap of \overline{CE} or \overline{SEM} LOW and R/ \bar{W} LOW. Both signals must be LOW to initiate a write, and either signal can terminate a write by going HIGH. The data input set-up and hold timing should be referenced to the rising edge of the signal that terminates the write.
22. If \overline{OE} is LOW during a R/ \bar{W} controlled write cycle, the write pulse width must be the larger of t_{PWE} or $(t_{HZWE} + t_{SD})$ to allow the I/O drivers to turn off and data to be placed on the bus for the required t_{SD} . If \overline{OE} is HIGH during a R/ \bar{W} controlled write cycle (as in this example), this requirement does not apply and the write pulse can be as short as the specified t_{PWE} .
23. R/ \bar{W} must be HIGH during all address transitions.

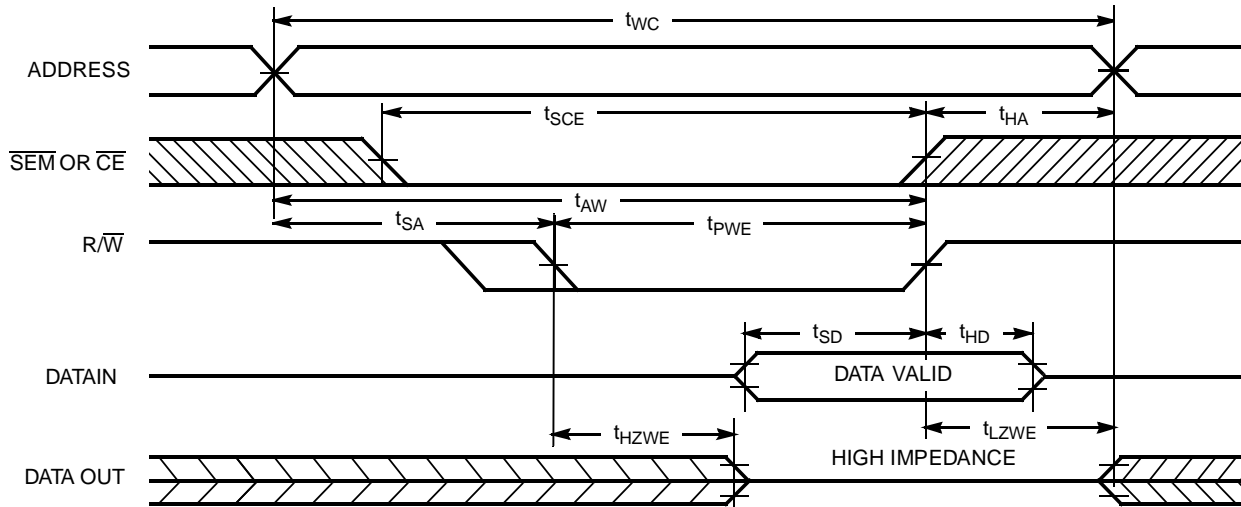
Switching Waveforms (continued)
Write Cycle No. 2: R/W Three-States Data I/Os (Either Port) ^[21, 23, 24]

C138-12

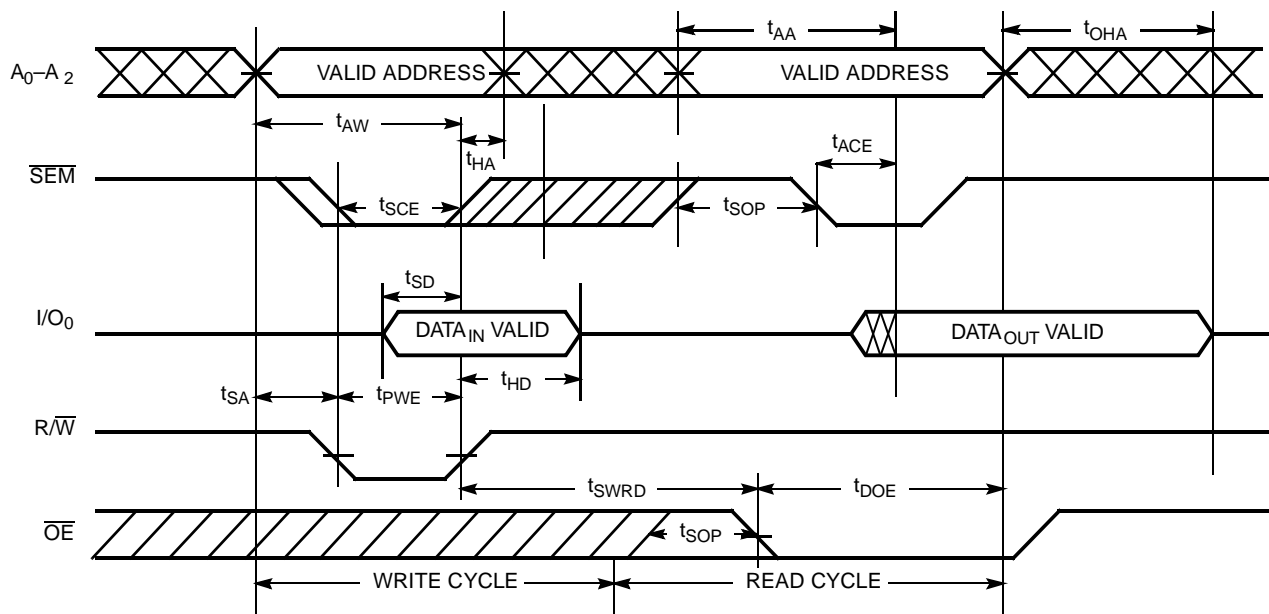
Semaphore Read After Write Timing, Either Side ^[25]

C138-13

Notes:

24. Data I/O pins enter high impedance when \overline{OE} is held LOW during write.
25. \overline{CE} = HIGH for the duration of the above timing (both write and read cycle).

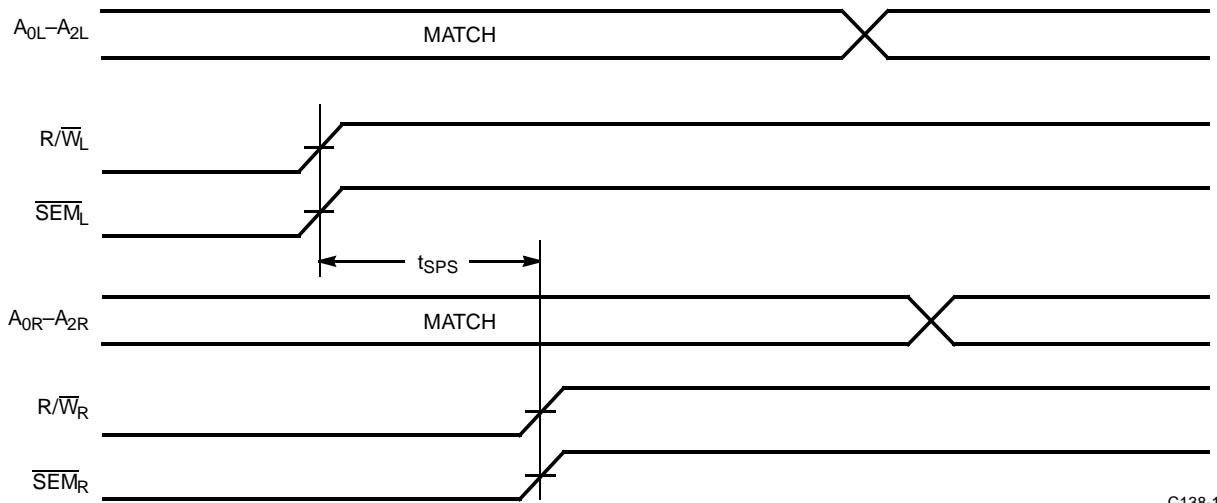
Switching Waveforms (continued)
Timing Diagram of Semaphore Contention [26, 27, 28]

C138-14

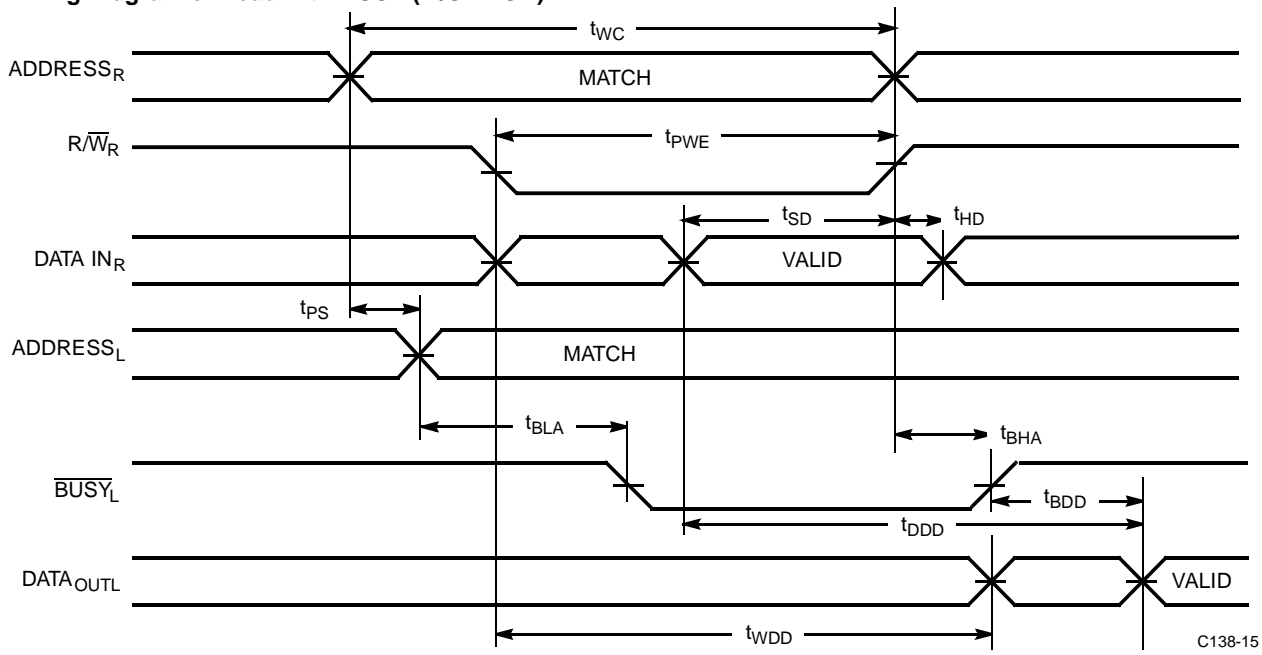
Timing Diagram of Read with \overline{BUSY} ($M/\overline{S}=\text{HIGH}$) [20]

C138-15

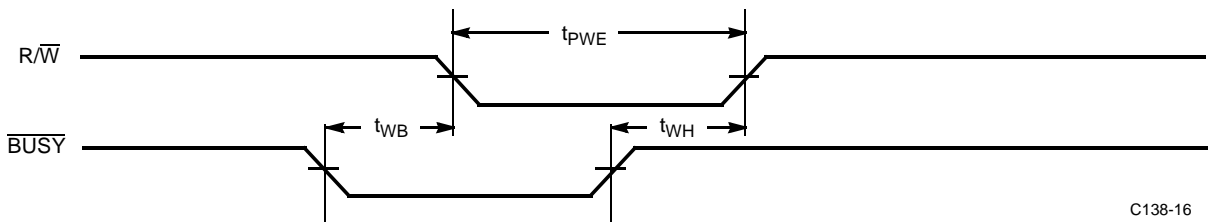
Write Timing with Busy Input ($M/\overline{S}=\text{LOW}$)

C138-16

Notes:

26. $I/O_{0R} = I/O_{0L} = \text{LOW}$ (request semaphore); $\overline{CE}_R = \overline{CE}_L = \text{HIGH}$
27. Semaphores are reset (available to both ports) at cycle start.
28. If t_{SPS} is violated, the semaphore will definitely be obtained by one side or the other, but there is no guarantee which side will control the semaphore.

Switching Waveforms (continued)

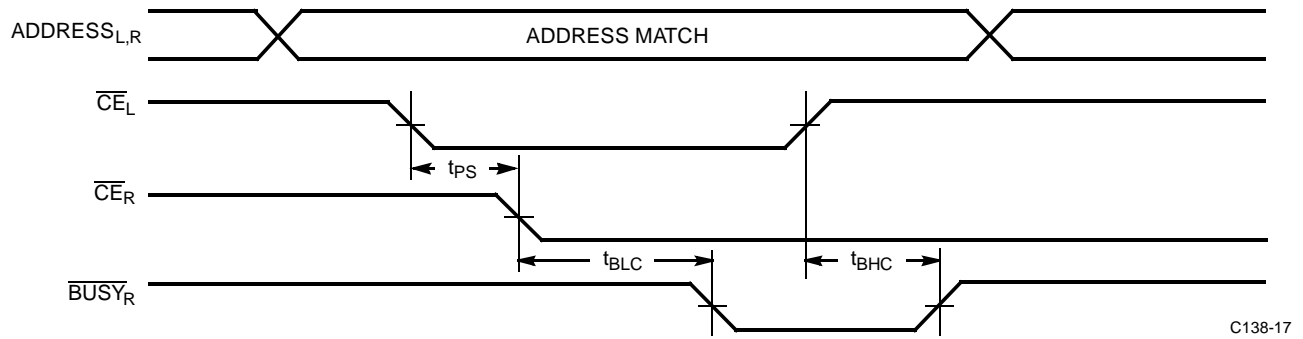
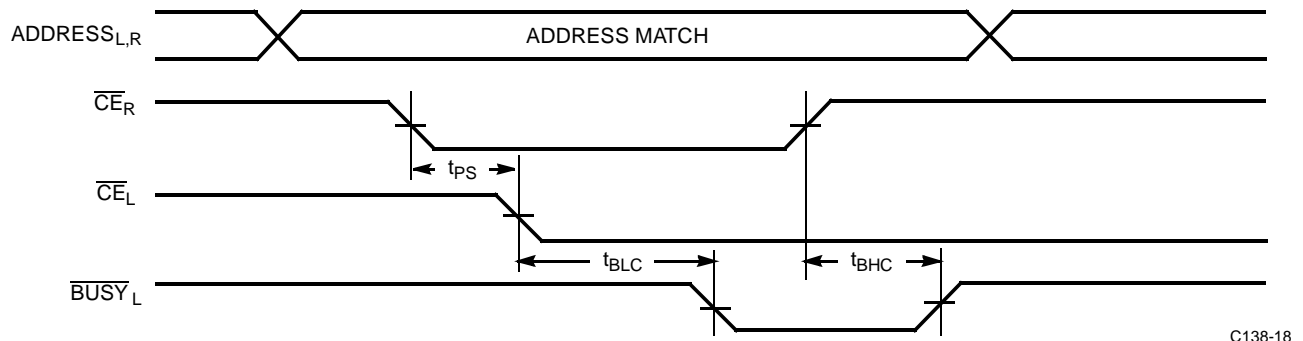
Busy Timing Diagram No. 1 (\overline{CE} Arbitration) ^[29]
 \overline{CE}_L Valid First:

 \overline{CE}_R Valid First:

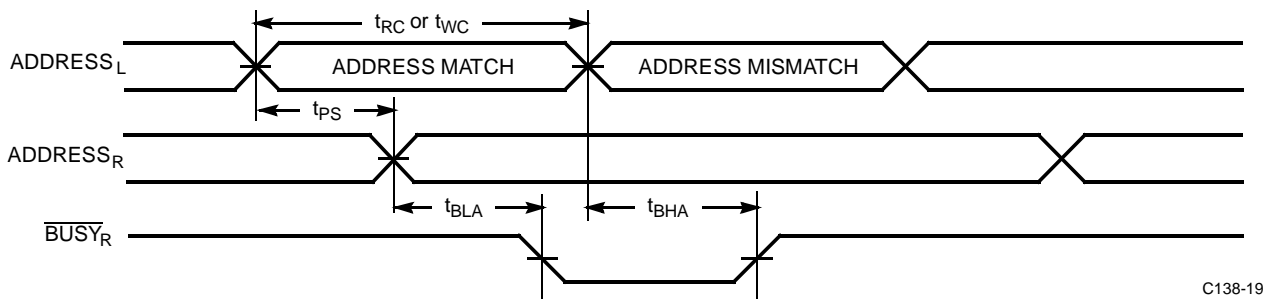
Busy Timing Diagram No. 2 (Address Arbitration) ^[29]

Left Address Valid First:

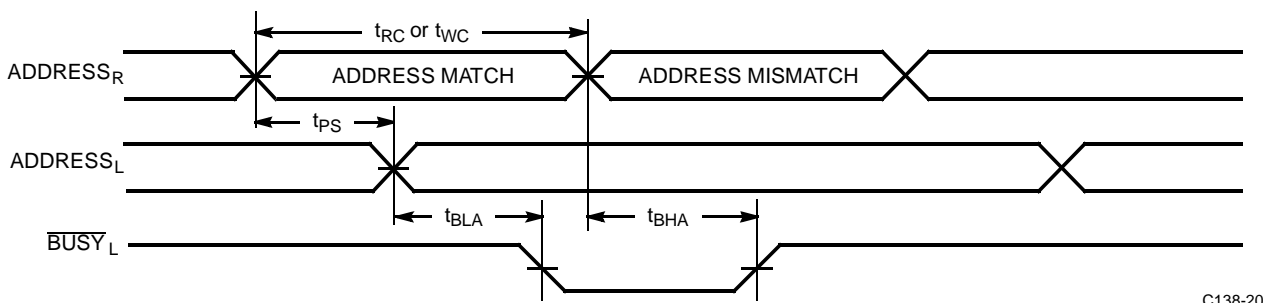

Right Address Valid First:



Note:

 29. If t_{PS} is violated, the busy signal will be asserted on one side or the other, but there is no guarantee on which side \overline{BUSY} will be asserted.

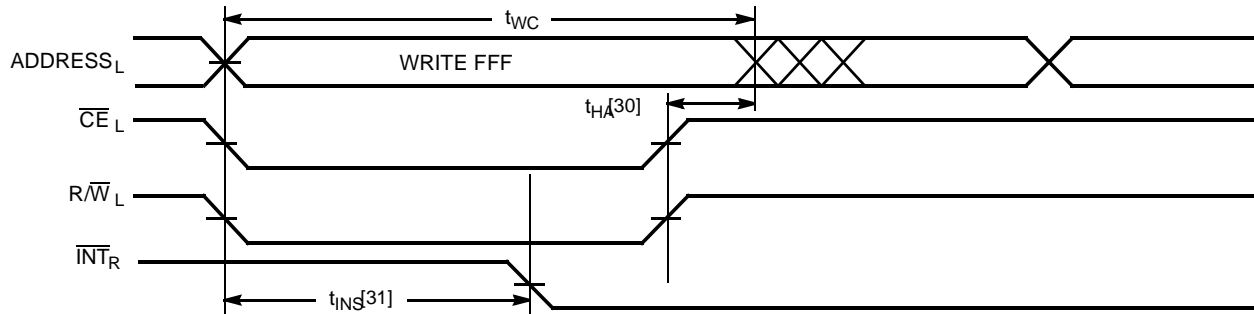
Switching Waveforms (continued)
Interrupt Timing Diagrams

 Left Side Sets $\overline{\text{INT}}_R$:

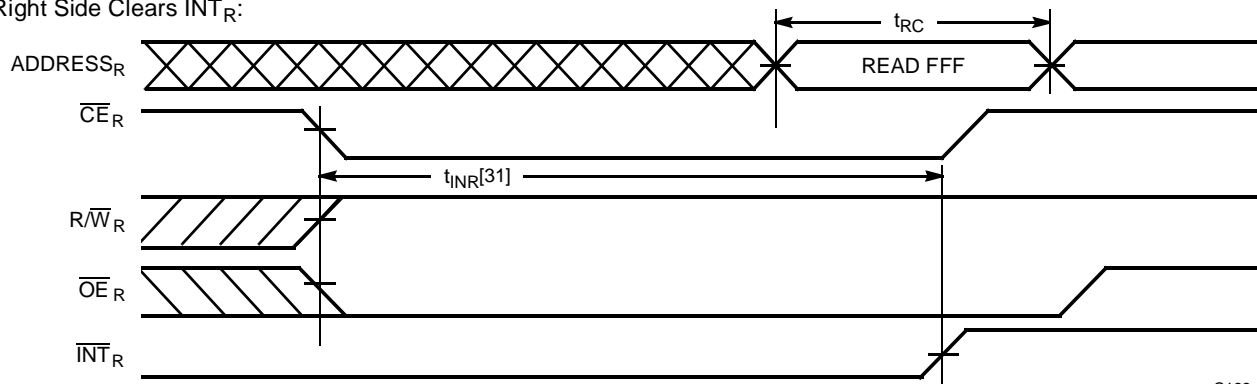
C138-21

 Right Side Clears $\overline{\text{INT}}_R$:

C138-22

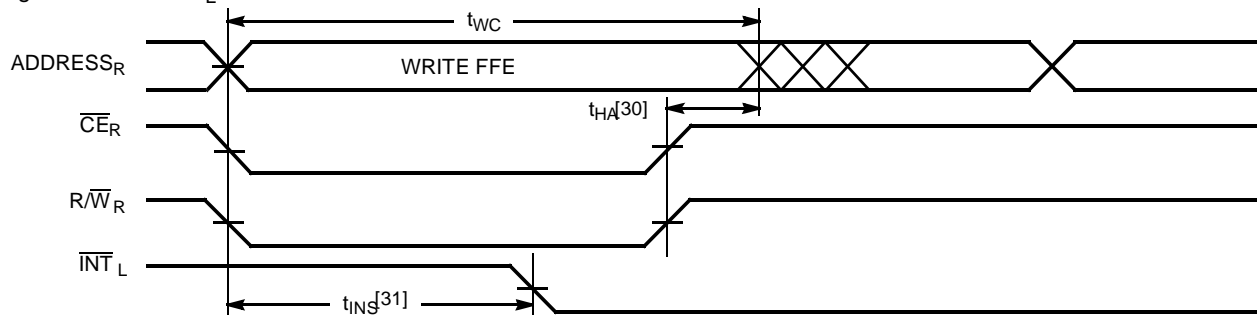
 Right Side Sets $\overline{\text{INT}}_L$:

C138-23

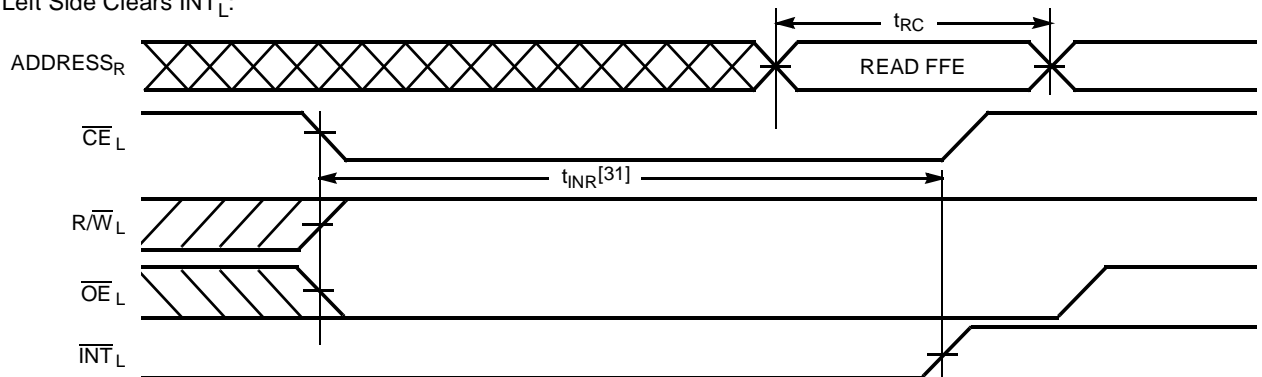
 Left Side Clears $\overline{\text{INT}}_L$:

C138-24

Notes:

30. t_{HA} depends on which enable pin ($\overline{\text{CE}}_L$ or $\overline{\text{R}}\overline{\text{W}}_L$) is deasserted first.
31. t_{INS} or t_{INR} depends on which enable pin ($\overline{\text{CE}}_L$ or $\overline{\text{R}}\overline{\text{W}}_L$) is asserted last.

Architecture

The CY7C138/9 consists of an array of 4K words of 8/9 bits each of dual-port RAM cells, I/O and address lines, and control signals (\overline{CE} , \overline{OE} , R/\overline{W}). These control pins permit independent access for reads or writes to any location in memory. To handle simultaneous writes/reads to the same location, a \overline{BUSY} pin is provided on each port. Two interrupt (\overline{INT}) pins can be utilized for port-to-port communication. Two semaphore (\overline{SEM}) control pins are used for allocating shared resources. With the M/\overline{S} pin, the CY7C138/9 can function as a master (\overline{BUSY} pins are outputs) or as a slave (\overline{BUSY} pins are inputs). The CY7C138/9 has an automatic power-down feature controlled by \overline{CE} . Each port is provided with its own output enable control (\overline{OE}), which allows data to be read from the device.

Functional Description

Write Operation

Data must be set up for a duration of t_{SD} before the rising edge of R/\overline{W} in order to guarantee a valid write. A write operation is controlled by either the \overline{OE} pin (see Write Cycle No. 1 waveform) or the R/\overline{W} pin (see Write Cycle No. 2 waveform). Data can be written to the device t_{HZOE} after the \overline{OE} is deasserted or t_{HZWE} after the falling edge of R/\overline{W} . Required inputs for non-contention operations are summarized in Table 1.

If a location is being written to by one port and the opposite port attempts to read that location, a port-to-port flowthrough delay must be met before the data is read on the output; otherwise the data read is not deterministic. Data will be valid on the port t_{DDD} after the data is presented on the other port.

Read Operation

When reading the device, the user must assert both the \overline{OE} and \overline{CE} pins. Data will be available t_{ACE} after \overline{CE} or t_{DOE} after \overline{OE} is asserted. If the user of the CY7C138/9 wishes to access a semaphore flag, then the \overline{SEM} pin must be asserted instead of the \overline{CE} pin.

Interrupts

The interrupt flag (\overline{INT}) permits communications between ports. When the left port writes to location FFF, the right port's interrupt flag (\overline{INT}_R) is set. This flag is cleared when the right port reads that same location. Setting the left port's interrupt flag (\overline{INT}_L) is accomplished when the right port writes to location FFE. This flag is cleared when the left port reads location FFE. The message at FFF or FFE is user-defined. See Table 2 for input requirements for \overline{INT} . \overline{INT}_R and \overline{INT}_L are push-pull outputs and do not require pull-up resistors to operate. \overline{BUSY}_L and \overline{BUSY}_R in master mode are push-pull outputs and do not require pull-up resistors to operate.

Busy

The CY7C138/9 provides on-chip arbitration to alleviate simultaneous memory location access (contention). If both ports' \overline{CE} s are asserted and an address match occurs within t_{PS} of each other the Busy logic will determine which port has access. If t_{PS} is violated, one port will definitely gain permission to the location, but it is not guaranteed which one. \overline{BUSY} will be asserted t_{BLA} after an address match or t_{BLC} after \overline{CE} is taken LOW.

Master/Slave

A M/\overline{S} pin is provided in order to expand the word width by configuring the device as either a master or a slave. The \overline{BUSY}

output of the master is connected to the \overline{BUSY} input of the slave. This will allow the device to interface to a master device with no external components. Writing of slave devices must be delayed until after the \overline{BUSY} input has settled. Otherwise, the slave chip may begin a write cycle during a contention situation. When presented as a HIGH input, the M/\overline{S} pin allows the device to be used as a master and therefore the \overline{BUSY} line is an output. \overline{BUSY} can then be used to send the arbitration outcome to a slave.

Semaphore Operation

The CY7C138/9 provides eight semaphore latches, which are separate from the dual-port memory locations. Semaphores are used to reserve resources that are shared between the two ports. The state of the semaphore indicates that a resource is in use. For example, if the left port wants to request a given resource, it sets a latch by writing a zero to a semaphore location. The left port then verifies its success in setting the latch by reading it. After writing to the semaphore, \overline{SEM} or \overline{OE} must be deasserted for t_{SOP} before attempting to read the semaphore. The semaphore value will be available $t_{SWRD} + t_{DOE}$ after the rising edge of the semaphore write. If the left port was successful (reads a zero), it assumes control over the shared resource, otherwise (reads a one) it assumes the right port has control and continues to poll the semaphore. When the right side has relinquished control of the semaphore (by writing a one), the left side will succeed in gaining control of the semaphore. If the left side no longer requires the semaphore, a one is written to cancel its request.

Semaphores are accessed by asserting \overline{SEM} LOW. The \overline{SEM} pin functions as a chip enable for the semaphore latches (\overline{CE} must remain HIGH during \overline{SEM} LOW). A_{0-2} represents the semaphore address. \overline{OE} and R/\overline{W} are used in the same manner as a normal memory access. When writing or reading a semaphore, the other address pins have no effect.

When writing to the semaphore, only I/O_0 is used. If a zero is written to the left port of an unused semaphore, a one will appear at the same semaphore address on the right port. That semaphore can now only be modified by the side showing zero (the left port in this case). If the left port now relinquishes control by writing a one to the semaphore, the semaphore will be set to one for both sides. However, if the right port had requested the semaphore (written a zero) while the left port had control, the right port would immediately own the semaphore as soon as the left port released it. Table 3 shows sample semaphore operations.

When reading a semaphore, all eight/nine data lines output the semaphore value. The read value is latched in an output register to prevent the semaphore from changing state during a write from the other port. If both ports attempt to access the semaphore within t_{SPS} of each other, the semaphore will definitely be obtained by one side or the other, but there is no guarantee which side will control the semaphore.

Initialization of the semaphore is not automatic and must be reset during initialization program at power-up. All semaphores on both sides should have a one written into them at initialization from both sides to assure that they will be free when needed.

Table 1. Non-Contending Read/Write

Inputs				Outputs	Operation
CE	R/W	OE	SEM	I/O _{0-7/8}	
H	X	X	H	High Z	Power-Down
H	H	L	L	Data Out	Read Data in Semaphore
X	X	H	X	High Z	I/O Lines Disabled
H		X	L	Data In	Write to Semaphore
L	H	L	H	Data Out	Read
L	L	X	H	Data In	Write
L	X	X	L		Illegal Condition

Table 2. Interrupt Operation Example (assumes $\overline{BUSY}_L = \overline{BUSY}_R = \text{HIGH}$)

Function	Left Port					Right Port				
	R/W	CE	OE	A ₀₋₁₁	INT	R/W	CE	OE	A ₀₋₁₁	INT
Set Left $\overline{\text{INT}}$	X	X	X	X	L	L	L	X	FFE	X
Reset Left $\overline{\text{INT}}$	X	L	L	FFE	H	X	X	X	X	X
Set Right $\overline{\text{INT}}$	L	L	X	FFF	X	X	X	X	X	L
Reset Right $\overline{\text{INT}}$	X	X	X	X	X	X	L	L	FFF	H

Table 3. Semaphore Operation Example

Function	I/O _{0-7/8} Left	I/O _{0-7/8} Right	Status
No action	1	1	Semaphore free
Left port writes semaphore	0	1	Left port obtains semaphore
Right port writes 0 to semaphore	0	1	Right side is denied access
Left port writes 1 to semaphore	1	0	Right port is granted access to semaphore
Left port writes 0 to semaphore	1	0	No change. Left port is denied access
Right port writes 1 to semaphore	0	1	Left port obtains semaphore
Left port writes 1 to semaphore	1	1	No port accessing semaphore address
Right port writes 0 to semaphore	1	0	Right port obtains semaphore
Right port writes 1 to semaphore	1	1	No port accessing semaphore
Left port writes 0 to semaphore	0	1	Left port obtains semaphore
Left port writes 1 to semaphore	1	1	No port accessing semaphore

Typical DC and AC Characteristics

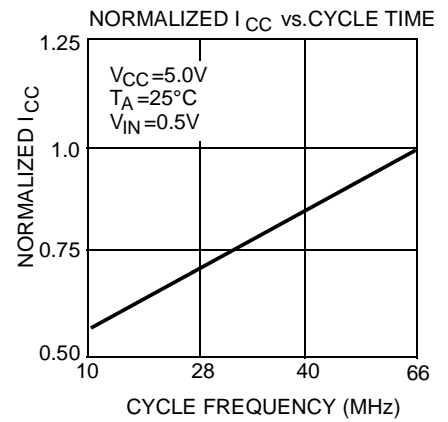
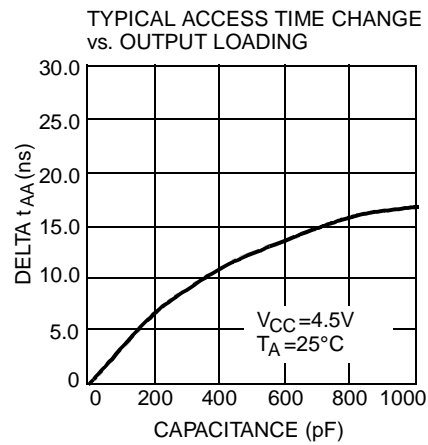
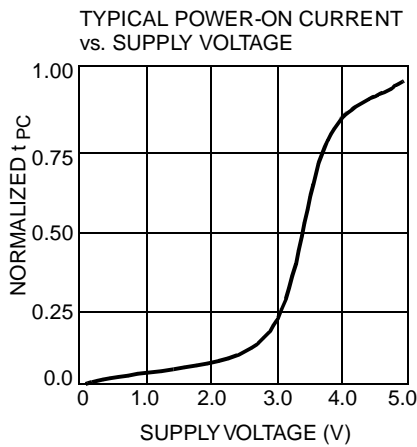
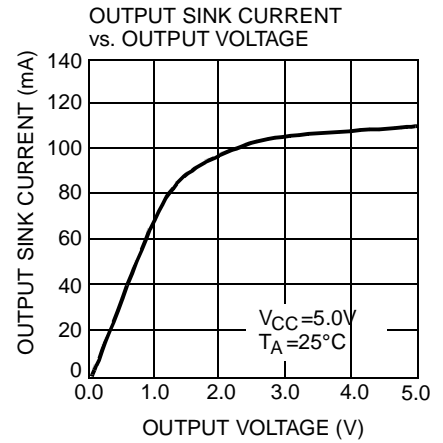
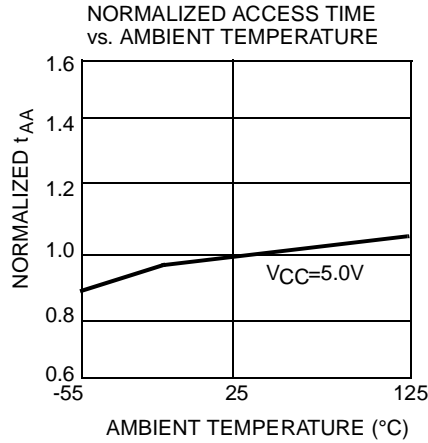
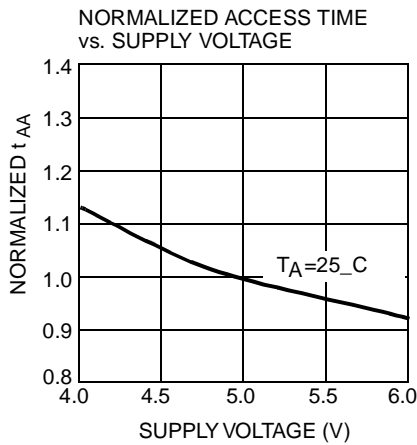
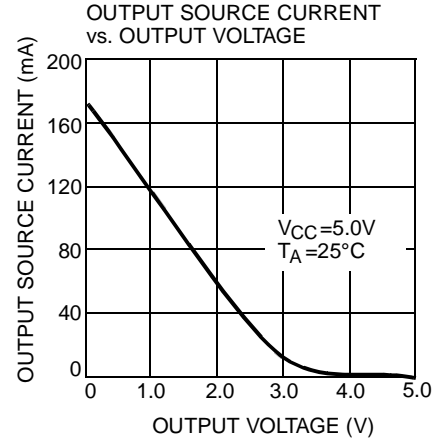
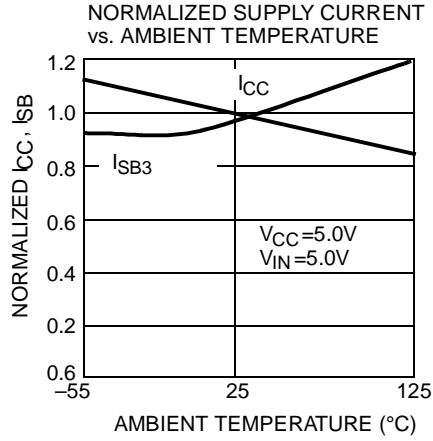
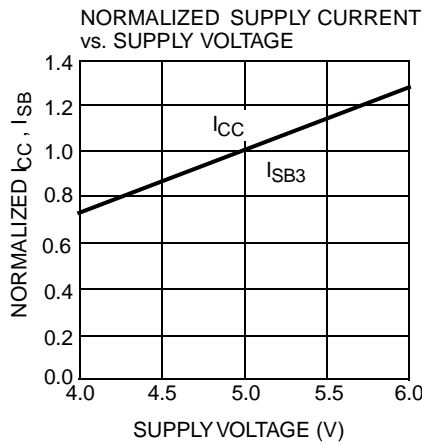

Ordering Information

4K x8 Dual-Port SRAM

Speed (ns)	Ordering Code	Package Name	Package Type	Operating Range
15	CY7C138-15JC	J81	68-Lead Plastic Leaded Chip Carrier	Commercial
25	CY7C138-25JC	J81	68-Lead Plastic Leaded Chip Carrier	Commercial
	CY7C138-25JI	J81	68-Lead Plastic Leaded Chip Carrier	Industrial
35	CY7C138-35JC	J81	68-Lead Plastic Leaded Chip Carrier	Commercial
	CY7C138-35JI	J81	68-Lead Plastic Leaded Chip Carrier	Industrial
55	CY7C138-55JC	J81	68-Lead Plastic Leaded Chip Carrier	Commercial
	CY7C138-55JI	J81	68-Lead Plastic Leaded Chip Carrier	Industrial

4K x9 Dual-Port SRAM

Speed (ns)	Ordering Code	Package Type	Package Type	Operating Range
15	CY7C139-15JC	J81	68-Lead Plastic Leaded Chip Carrier	Commercial
25	CY7C139-25JC	J81	68-Lead Plastic Leaded Chip Carrier	Commercial
	CY7C139-25JI	J81	68-Lead Plastic Leaded Chip Carrier	Industrial
35	CY7C139-35JC	J81	68-Lead Plastic Leaded Chip Carrier	Commercial
	CY7C139-35JI	J81	68-Lead Plastic Leaded Chip Carrier	Industrial
55	CY7C139-55JC	J81	68-Lead Plastic Leaded Chip Carrier	Commercial
	CY7C139-55JI	J81	68-Lead Plastic Leaded Chip Carrier	Industrial

Document #: 38-00536

Package Diagram

68-Lead Plastic Leaded Chip Carrier J81

