



### Description

The ICS411 is a cost-effective clock synthesizer developed to optimize component count for PC motherboard and peripheral applications. The device supports a common, low cost 14.31818 MHz crystal. The device locks all output frequencies to enhance system performance. By supporting common PC peripheral interface frequencies including 25 MHz for Ethernet and 24.576 MHz for audio and other applications, the device lowers chip count enhancing system cost and reliability.

The ICS411 utilizes a low pin count 8-pin SOIC package to optimize board space.

ICS is a leader in low jitter and power consumer application clock sources. These devices are capable of supporting CCD, video, audio, USB, CPU, and other peripherals.

### Features

- Low operating voltage of 3.3 V
- Accepts 14.31818 MHz clock input to lower jitter
- Fixed dual 25 MHz clocks for Ethernet
- Fixed 24.576 MHz clock
- Power consumption of 15 mA (typ) extends battery life
- Duty cycle of 45 to 55% (24.576M)
- Packaged in 8-pin SOIC
- Available in Pb (lead) free package
- Contact ICS for custom frequency requirements

### Block Diagram

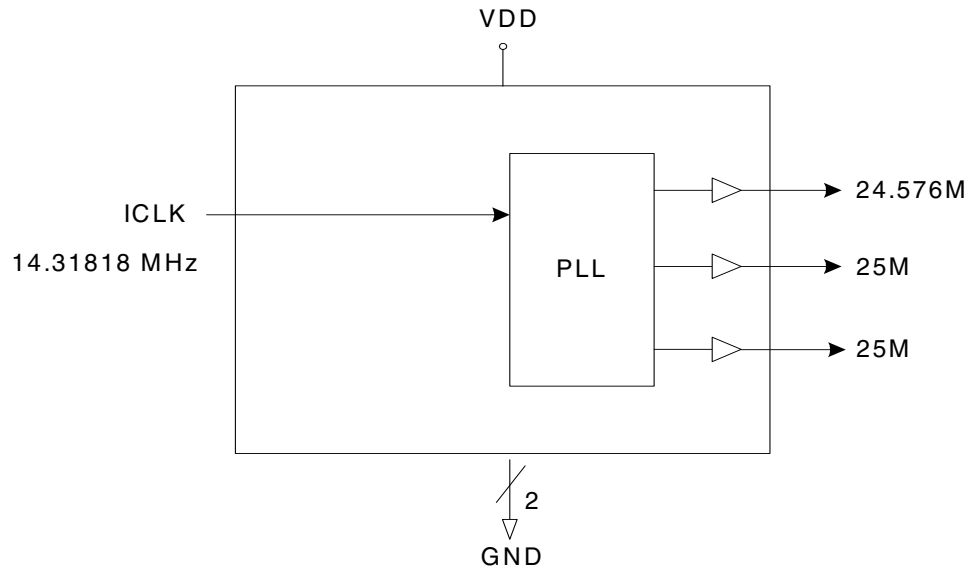



## Pin Assignment

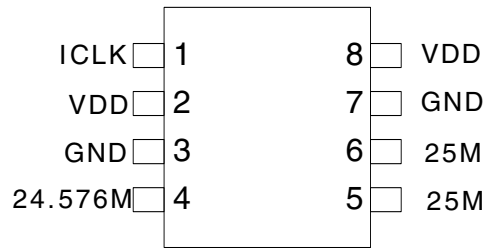

8 Pin (150 mil) SOIC

## Pin Descriptions

Pin Number	Pin Name	Pin Type	Pin Description
1	ICLK	Input	Clock connection. Connect to 14.31818 MHz clock.
2	VDD	Power	Connect to voltage supply.
3	GND	Power	Connect to ground.
4	24.576M	Output	24.576 MHz clock output.
5	25M	Output	25 MHz clock output.
6	25M	Output	25 MHz clock output.
7	GND	Power	Connect to ground.
8	VDD	Power	Connect to voltage supply.



## External Components

### Series Termination Resistor

Clock output traces over one inch should use series termination. To series terminate a 50Ω trace (a commonly used trace impedance), place a 33Ω resistor in series with the clock line, as close to the clock output pin as possible. The nominal impedance of the clock output is 20Ω.

### Decoupling Capacitor

As with any high performance mixed-signal IC, the ICS411 must be isolated from system power supply noise to perform optimally.

Decoupling capacitors of 0.01μF must be connected between each VDD pin and the PCB ground plane.

## PCB Layout Recommendations

For optimum device performance and lowest output phase noise, the following guidelines should be observed.

- 1) 0.01μF decoupling capacitors should be mounted on the component side of the board as close to the VDD pin as possible. No vias should be used between decoupling capacitor and VDD pin. The PCB trace to VDD pin should be kept as short as possible, as should the PCB trace to the ground via.
- 2) To minimize EMI the 33Ω series termination resistor, if needed, should be placed close to the clock output.
- 3) An optimum layout is one with all components on the same side of the board, minimizing vias through other signal layers. Other signal traces should be routed away from the ICS411. This includes signal traces just underneath the device, or on layers adjacent to the ground plane layer used by the device.

## Absolute Maximum Ratings

Stresses above the ratings listed below can cause permanent damage to the ICS411. These ratings, which are standard values for ICS commercially rated parts, are stress ratings only. Functional operation of the device at these or any other conditions above those indicated in the operational sections of the specifications is not implied. Exposure to absolute maximum rating conditions for extended periods can affect product reliability. Electrical parameters are guaranteed only over the recommended operating temperature range.

Item	Rating
Supply Voltage, VDD	7 V
All Inputs and Outputs	-0.5 V to VDD+0.5 V
Ambient Operating Temperature	0 to +70 °C
Storage Temperature	-65 to +150 °C
Junction Temperature	125°C
Soldering Temperature	260°C

## Recommended Operation Conditions

Parameter	Min.	Typ.	Max.	Units
Ambient Operating Temperature	0	–	+70	°C
Power Supply Voltage (measured in respect to GND)	+3.00		+3.60	V



## DC Electrical Characteristics

VDD=3.3 V ±10% Notes: 1. Nominal switching threshold is VDD/2

Parameter	Symbol	Conditions	Min.	Typ.	Max.	Units
Operating Voltage	VDD		3.0		3.6	V
Input High Voltage	V <sub>IH</sub>	Note 1	2.0			V
Input Low Voltage	V <sub>IL</sub>	Note 1			0.8	V
Output High Voltage	V <sub>OH</sub>	I <sub>OH</sub> = -25 mA	2.4			V
Output Low Voltage	V <sub>OL</sub>	I <sub>OL</sub> = 25 mA			0.8	V
Operating Supply Current	IDD	No load		8		mA
Short Circuit Current	I <sub>OS</sub>	Each output		80		mA

## AC Electrical Characteristics

VDD = 3.3 V ±10%, Ambient Temperature 0 to +70° C

Parameter	Symbol	Conditions	Min.	Typ.	Max.	Units
Input Frequency				14.318		MHz
Output Rise Time	t <sub>OR</sub>	0.8 to 2.0 V, C <sub>L</sub> =15 pF		0.60		ns
Output Fall Time	t <sub>OF</sub>	2.0 to 0.8 V, C <sub>L</sub> =15 pF		0.60		ns
Output Clock Duty Cycle		At VDD/2, 24.576M	45	50	55	%
Absolute Jitter, Short Term		Variation from mean, 24.576M		150		ps
Absolute Jitter, Short Term		Variation from mean, 25M		115		ps



## Package Outline and Package Dimensions (8-pin SOIC, 150 Mil. Narrow Body)

Package dimensions are kept current with JEDEC Publication No. 95

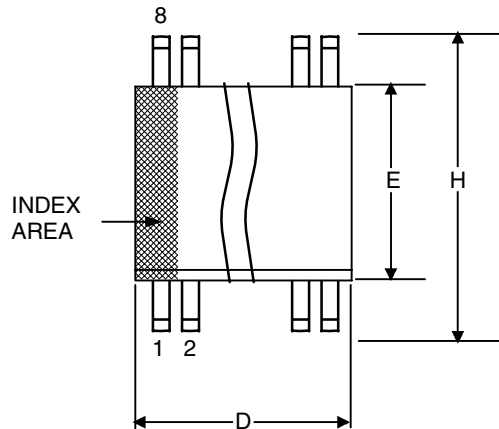

Symbol	Millimeters		Inches*	
	Min	Max	Min	Max
A	1.35	1.75	.0532	.0688
A1	0.10	0.25	.0040	.0098
B	0.33	0.51	.013	.020
C	0.19	0.25	.0075	.0098
D	4.80	5.00	.1890	.1968
E	3.80	4.00	.1497	.1574
e	1.27 BASIC		0.050 BASIC	
H	5.80	6.20	.2284	.2440
h	0.25	0.50	.010	.020
L	0.40	1.27	.016	.050
$\alpha$	0°	8°	0°	8°

\*For reference only. Controlling dimensions in mm.

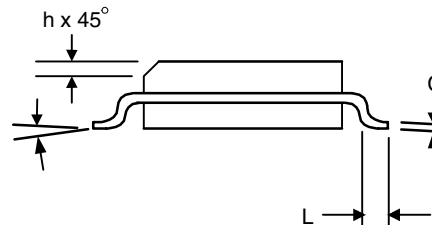
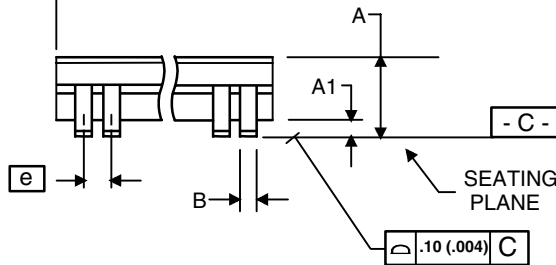

## Ordering Information

Part / Order Number	Marking	Shipping Packaging	Package	Temperature
ICS411M	ICS411	Tubes	8-pin SOIC	0 to +70°C
ICS411MT	ICS411	Tape and Reel	8-pin SOIC	0 to +70°C
ICS411MLF	ICS411LF	Tubes	8-pin SOIC	0 to +70°C
ICS411MLFT	ICS411LF	Tape and Reel	8-pin SOIC	0 to +70°C

Parts that are ordered with a "LF" suffix to the part number are the Pb-Free configuration and are RoHS compliant.

While the information presented herein has been checked for both accuracy and reliability, Integrated Circuit Systems (ICS) assumes no responsibility for either its use or for the infringement of any patents or other rights of third parties, which would result from its use. No other circuits, patents, or licenses are implied. This product is intended for use in normal commercial applications. Any other applications such as those requiring extended temperature range, high reliability, or other extraordinary environmental requirements are not recommended without additional processing by ICS. ICS reserves the right to change any circuitry or specifications without notice. ICS does not authorize or warrant any ICS product for use in life support devices or critical medical instruments.