

MAXIM

MAX3274 Evaluation Kit

Evaluates: MAX3274

General Description

The MAX3274 evaluation kit (EV kit) simplifies evaluation of the MAX3274 limiting amplifier. The EV kit allows quick threshold level selections, provides appropriate impedance matching circuitry, and includes calibration circuits. The MAX3274 EV kit is fully assembled and tested.

Features

- ◆ Test Points for Easy Monitoring of LOS and $\overline{\text{LOS}}$
- ◆ Separate Pullup Supply (VLOS) Pin for LOS and $\overline{\text{LOS}}$ Outputs
- ◆ Jumpers Allow Quick Selection for Loss-of-Signal Threshold Level, Squelch, and Bandwidth

Component List

DESIGNATION	QTY	DESCRIPTION
C1, C4	2	33 μ F \pm 10%, 10V min tantalum capacitors (case B)
C2, C5–C15	12	0.1 μ F \pm 10%, 10V min ceramic capacitors (0402)
C3	1	0.1 μ F \pm 10%, 10V min ceramic capacitor (0603)
J1–J8	8	SMA connectors, edge mount, tab centers EFJohnson 142-0701-851
JU1–JU4, JU6, JU7	6	2-pin headers, 0.1in centers
JU1–JU4, JU6, JU7	6	Shunts
L1	1	4.7 μ H inductor Coilcraft 1008CT-040XKBC (1008)
R1, R2, R6, R8	4	4.7k Ω \pm 5% resistors (0402)
R3	1	1.5k Ω \pm 1% resistor (0402)
R4	1	681 Ω \pm 1% resistor (0402)
R5	2	401 Ω \pm 1% resistor (0402)
R9, R10	2	Open
TP1, TP2, GND, VCC, VLOS	5	Test points Digi-Key 5000K-ND
U1	1	MAX3274UGE (MAX3274EVKIT)
None	1	MAX3274, rev B, EV kit circuit board
None	1	MAX3274 data sheet

Ordering Information

PART	TEMP RANGE	IC PACKAGE
MAX3274EVKIT	0°C to +85°C	16 QFN

Component Suppliers

SUPPLIER	PHONE	FAX
AVX	803-946-0690	803-626-3123
Coilcraft	847-639-6400	847-639-1469
Murata	770-436-1300	770-436-3030
Venkel	800-950-8365	512-794-0087

MAX3274 Evaluation Kit

Quick Start

- 1) Connect OUT+ and OUT- to a 50 Ω terminated oscilloscope.
- 2) Connect IN+ and IN- to a 500mV_{P-P}, 2.125Gbps differential data stream.
- 3) Remove jumper JU6 to disable squelch.
- 4) Connect shunt at jumper JU7 to use VCC as the pullup supply for LOS and $\overline{\text{LOS}}$ outputs.
- 5) Connect shunt at jumper JU4 for 2.125Gbps operation.
- 6) Connect a +3.3V power supply to the VCC pad, and then connect the power-supply ground to the GND pad.
- 7) Observe a limited signal at the output ($\sim 1.1\text{V}_{P-P}$ differential for the MAX3274).

Detailed Description

The MAX3274 dual-rate limiting amplifier is designed to accept a differential signal from a 100 Ω differential output transimpedance preamplifier. In order for output data to be valid, incoming data must be above the threshold voltage set by placing a shunt at jumper JU1, JU2, or JU3. LOS and $\overline{\text{LOS}}$ are open-collector outputs and indicate whether the input data stream voltage is below the threshold voltage. The EV kit supplies the required pullup resistors for LOS and $\overline{\text{LOS}}$. Placing a shunt at jumper JU6 enables squelch and disables output if incoming data voltage is below the threshold level. The shunt can be removed from jumper JU7 if the user wants to interface the LOS and $\overline{\text{LOS}}$ pins with a voltage different from VCC. With a shunt at jumper JU4, the input filter is disabled and the chip is ready to accept data at 2.125Gbps. To evaluate the chip at 1.0625Gbps, remove the shunt at jumper JU4.

Calibration Strip

The calibration strip can be used to calibrate out the effects of the circuit board, such as connectors, in critical measurements such as deterministic jitter and rise/fall times.

Table 1. Jumpers

NAME	FUNCTION
JU1, JU2, JU3	Select loss-of-signal threshold level
JU4	Selects input bandwidth, open for 1.0625Gbps and closed for 2.125Gbps
JU6	Closed to enable squelch, opened to disable squelch
JU7	When using an external pullup supply for LOS and $\overline{\text{LOS}}$ other than VCC, remove jumper

MAX3274 Evaluation Kit

Evaluates: MAX3274

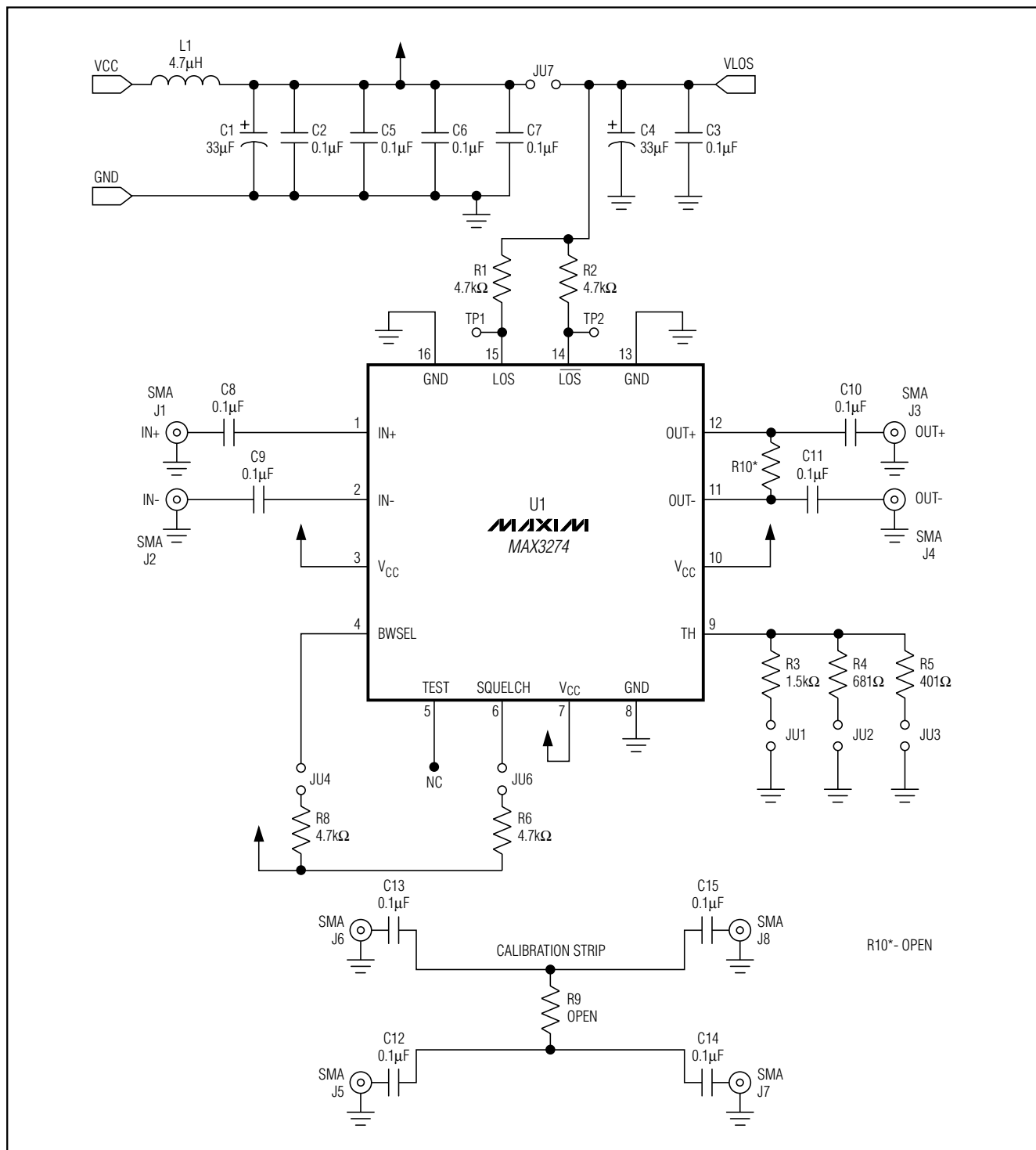

Figure 1. MAX3274 EV Kit Schematic

MAX3274 Evaluation Kit

Evaluates: MAX3274

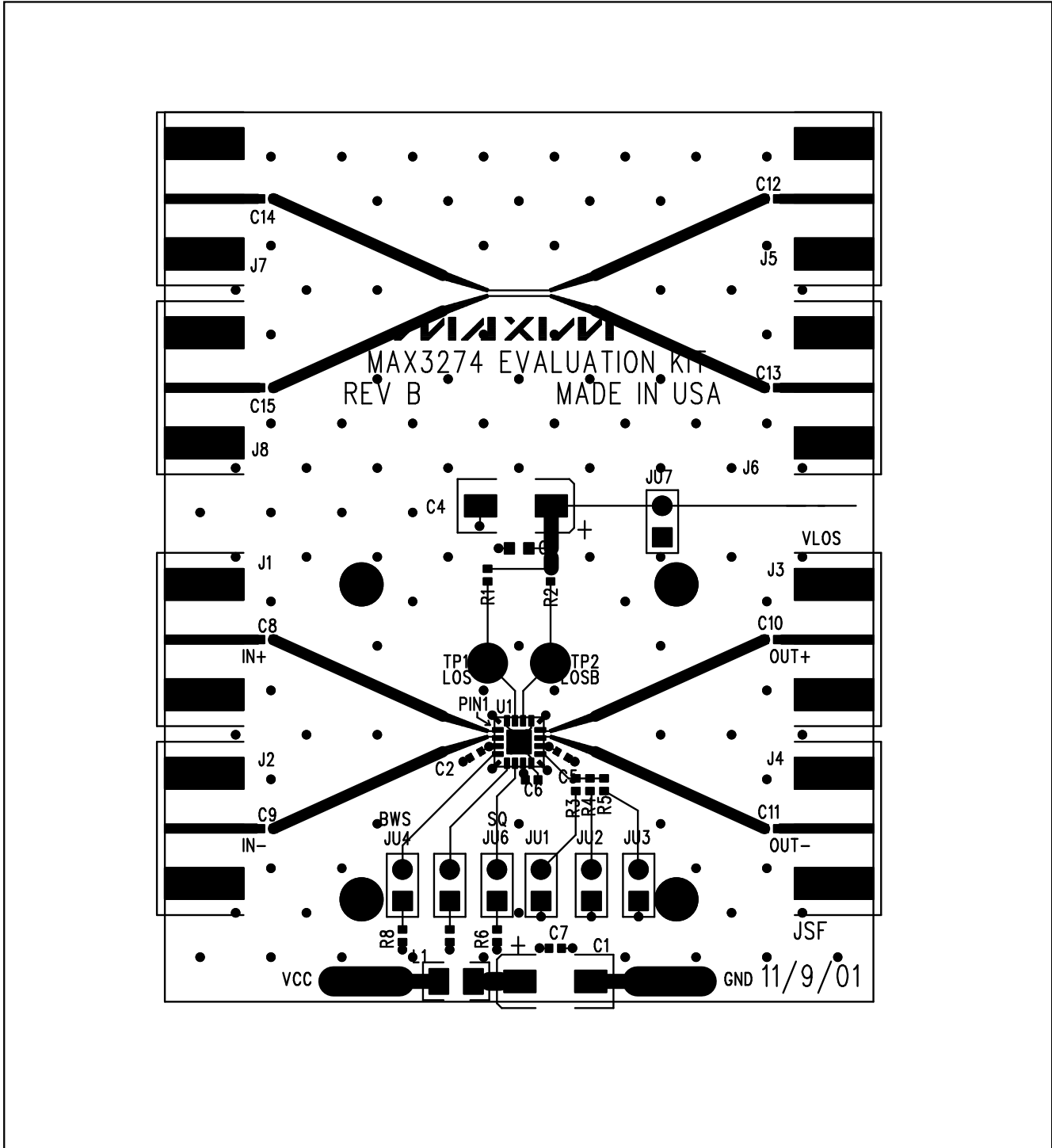

Figure 2. MAX3274 EV Kit Component Placement Guide—Component Side

MAX3274 Evaluation Kit

Evaluates: MAX3274

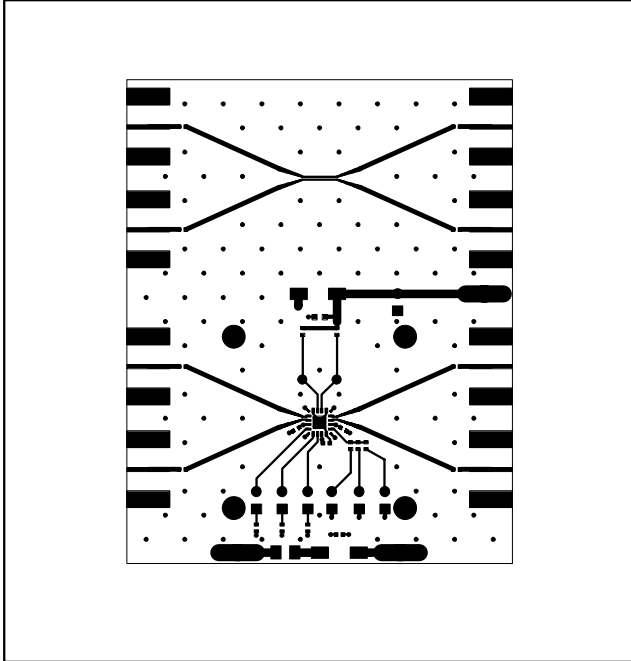

Figure 3. MAX3274 EV Kit PC Board Layout—Component Side

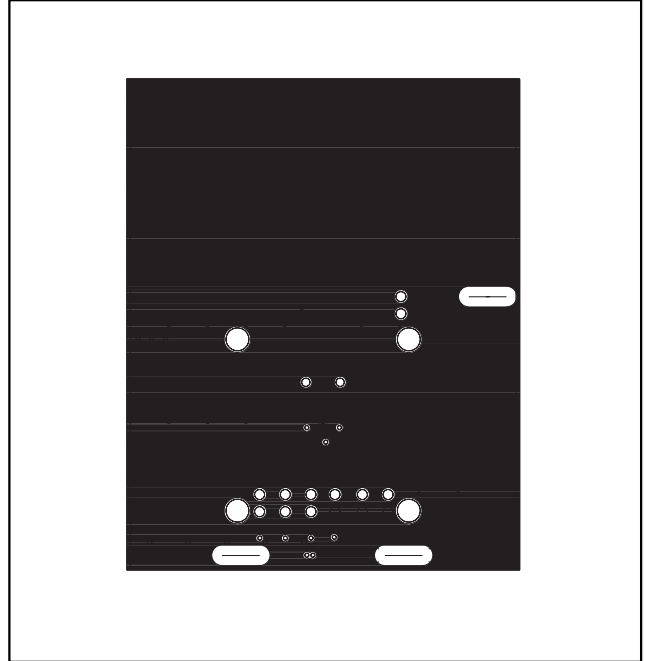

Figure 4. MAX3274 EV Kit PC Board Layout—Ground Plane

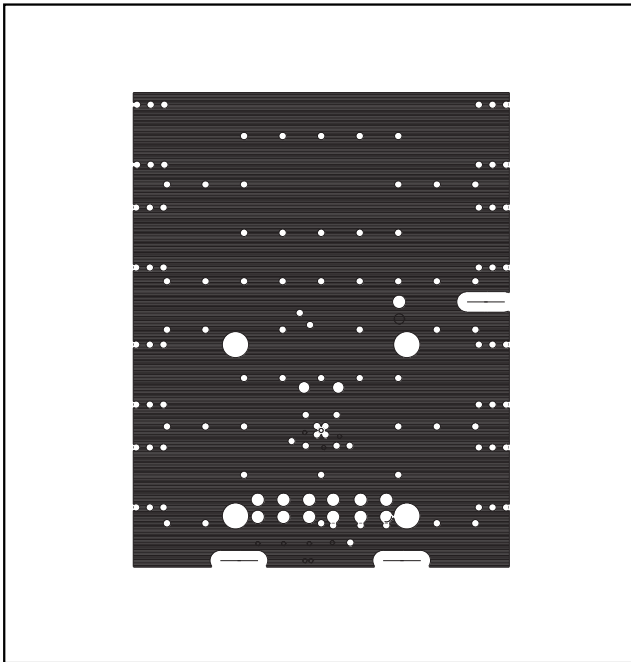

Figure 5. MAX3274 EV Kit PC Board Layout—Power Plane

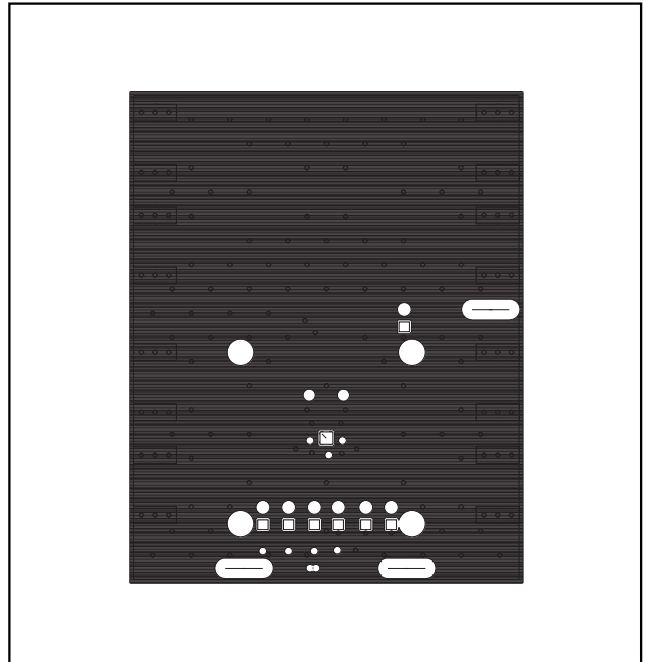

Figure 6. MAX3274 EV Kit PC Board Layout—Solder Side

Maxim cannot assume responsibility for use of any circuitry other than circuitry entirely embodied in a Maxim product. No circuit patent licenses are implied. Maxim reserves the right to change the circuitry and specifications without notice at any time.

Maxim Integrated Products, 120 San Gabriel Drive, Sunnyvale, CA 94086 408-737-7600 _____ 5