



# TEA5764HN

FM radio + RDS

Rev. 02 — 9 August 2005

Product data sheet

## 1. General description

The TEA5764HN is a single chip electronically tuned FM stereo radio with Radio Data System (RDS) and Radio Broadcast Data System (RBDS) demodulator and RDS/RBDS decoder for portable application with fully integrated IF selectivity and demodulation.

The radio is completely adjustment free and only requires a minimum of small and low cost external components.

The radio can tune to the European, US and Japanese FM bands. It has a low power consumption and can operate at a low supply voltage.

## 2. Features

- High sensitivity due to integrated low noise RF input amplifier
- FM mixer for conversion of the US/Europe (87.5 MHz to 108 MHz) and Japanese FM band (76 MHz to 90 MHz) to IF
- Preset tuning to receive Japanese TV audio up to 108 MHz
- Auto search tuning, raster 100 kHz
- RF automatic gain control circuit
- LC tuner oscillator operating with low cost fixed chip inductors
- Fully integrated FM IF selectivity
- Fully integrated FM demodulator;
- no external discriminator
- Crystal oscillator at 32768 Hz, or external reference frequency at 32768 Hz
- PLL synthesizer tuning system
- IF counter; 7-bit output via the I<sup>2</sup>C-bus
- Level detector; 4-bit level information output via the I<sup>2</sup>C-bus
- Soft mute: signal dependent mute function
- Mono/stereo blend: gradual change from mono to stereo, depending on signal
- Adjustment-free stereo decoder
- Autonomous search tuning function
- Standby mode
- MPX output
- One software programmable port
- Fully integrated RDS/RBDS demodulator in accordance with EN50067
- RDS/RBDS decoder with memory for two RDS data blocks provides block synchronization and error correction; block data and status information are available via the I<sup>2</sup>C-bus
- Audio pause detector

# PHILIPS

- Interrupt flag

### 3. Applications

- FM stereo radio

### 4. Quick reference data

**Table 1: Electrical parameters general**

The listed parameters are valid when a crystal is used that meets the requirements as stated in [Table 47](#); All RF input values are defined in potential difference, except when EMF is explicitly stated.

Symbol	Parameter	Conditions	Min	Typ	Max	Unit
<b>Supplies</b>						
$V_{CCA}$	analog supply voltage		2.5	2.7	3.3	V
$I_{CCA}$	analog supply current	$V_{CCA} = 2.5\text{ V to }3.3\text{ V}$				
		operating mode	12	13.7	16	mA
		Standby mode	0	0.1	1	$\mu\text{A}$
$V_{CCD}$	digital supply voltage		2.5	2.7	3.3	V
$I_{CCD}$	digital supply current	$V_{CCD} = 2.5\text{ V to }3.3\text{ V}$				
		operating mode	0.3	0.7	1.5	mA
		Standby mode	1	15	22.5	$\mu\text{A}$
<b>Reference voltage</b>						
$V_{VREFDIG}$	digital reference voltage for I <sup>2</sup> C-bus interface		1.65	1.8	$V_{CCD}$	V
$I_{VREFDIG}$	digital reference supply current	operating mode; $V_{VREFDIG} = 1.65\text{ V to }V_{CCD}$	0	0.5	1	$\mu\text{A}$
<b>General</b>						
$f_{i(\text{FM})}$	FM input frequency		76	-	108	MHz
$T_{\text{amb}}$	ambient temperature		-40	-	+85	$^{\circ}\text{C}$
<b>FM and RDS overall system parameters</b>						
$V_{\text{sens(EMF)}}$	sensitivity EMF value voltage	$f_{\text{RF}} = 76\text{ MHz to }108\text{ MHz};$ $\Delta f = 22.5\text{ kHz}; f_{\text{mod}} = 1\text{ kHz};$ $(\text{S}+\text{N})/\text{N} = 26\text{ dB}; \text{TC}_{\text{deem}} = 75\text{ }\mu\text{s};$ A-weighting filter; $B_{\text{aud}} = 300\text{ Hz to }15\text{ kHz}$	-	2.3	3.5	$\mu\text{V}$
$\text{IP3}_{\text{in}}$	in-band 3rd-order intercept point	$\Delta f_1 = 200\text{ kHz}; \Delta f_2 = 400\text{ kHz};$ $f_{\text{tune}} = 76\text{ MHz to }108\text{ MHz};$ $\text{RF}_{\text{agc}} = \text{off}$	78	87	-	$\text{dB}\mu\text{V}$
$\text{IP3}_{\text{out}}$	out-of-band 3rd-order intercept point	$\Delta f_1 = 4\text{ MHz}; \Delta f_2 = 8\text{ MHz};$ $f_{\text{tune}} = 76\text{ MHz to }108\text{ MHz};$ $\text{RF}_{\text{agc}} = \text{off}$	87	93	-	$\text{dB}\mu\text{V}$
S	selectivity	$f_{\text{tune}} = 76\text{ MHz to }108\text{ MHz}$	<a href="#">[1]</a>			
		high-side; $\Delta f = +200\text{ kHz}$	39	43	-	dB
		low-side; $\Delta f = -200\text{ kHz}$	32	36	-	dB
$V_{\text{VAFL}}$	left audio output voltage on pin VAFL	$V_{\text{RF}} = 1\text{ mV}; L = R; \Delta f = 22.5\text{ kHz};$ $f_{\text{mod}} = 1\text{ kHz};$ no pre-emphasis; $\text{TC}_{\text{deem}} = 75\text{ }\mu\text{s}$	55	66	75	mV

**Table 1: Electrical parameters general**

The listed parameters are valid when a crystal is used that meets the requirements as stated in [Table 47](#); All RF input values are defined in potential difference, except when EMF is explicitly stated.

Symbol	Parameter	Conditions	Min	Typ	Max	Unit
$V_{\text{VAFR}}$	right audio output voltage on pin VAFR	$V_{\text{RF}} = 1 \text{ mV}$ ; $L = R$ ; $\Delta f = 22.5 \text{ kHz}$ ; $f_{\text{mod}} = 1 \text{ kHz}$ ; no pre-emphasis; $TC_{\text{deem}} = 75 \mu\text{s}$	55	66	75	mV
(S+N)/N(m)	maximum signal-to-noise ratio, mono	$V_{\text{RF}} = 1 \text{ mV}$ ; $\Delta f = 22.5 \text{ kHz}$ ; $L = R$ ; $f_{\text{mod}} = 1 \text{ kHz}$ ; de-emphasis = $75 \mu\text{s}$ ; $B_{\text{AF}} = 300 \text{ Hz}$ to $15 \text{ kHz}$ ; A-weighting filter	54	57	-	dB
(S+N)/N(s)	maximum signal-to-noise ratio, stereo	$V_{\text{RF}} = 1 \text{ mV}$ ; $\Delta f = 67.5 \text{ kHz}$ ; $L = R$ ; $f_{\text{mod}} = 1 \text{ kHz}$ ; $\Delta f_{\text{pilot}} = 6.75 \text{ kHz}$ ; de-emphasis = $75 \mu\text{s}$ ; $B_{\text{AF}} = 300 \text{ Hz}$ to $15 \text{ kHz}$ ; A-weighting filter	50	54	-	dB
$\alpha_{\text{cs}}$	channel separation	$MST = 0$ ; $R = 1$ and $L = 0$ or $R = 0$ and $L = 1$ ; $V_{\text{RF}} = 30 \mu\text{V}$ ; increasing RF input level	27	33	-	dB
THD	total harmonic distortion	$V_{\text{RF}} = 1 \text{ mV}$ ; $\Delta f = 75 \text{ kHz}$ ; $f_{\text{mod}} = 1 \text{ kHz}$ ; $DTC = 0$ ; $B_{\text{aud}} = 300 \text{ Hz}$ to $15 \text{ kHz}$ ; A-weighting filter; mono; $L = R$ ; no pilot deviation	-	0.4	0.9	%
$V_{\text{sens}}$	RDS sensitivity EMF value	$\Delta f = 22.5 \text{ kHz}$ ; $f_{\text{AF}} = 1 \text{ kHz}$ ; $L = R$ ; $SYM1 = 0$ and $SYM0 = 0$ ; average over 2000 blocks; block quality rate $\geq 95 \%$ ; $\Delta f_{\text{RDS}} = 2 \text{ kHz}$	-	15	26	$\mu\text{V}$

[1] Low-side and high-side selectivity can be measured by changing the mixer LO injection from high-side to low-side.

## 5. Ordering information

**Table 2: Ordering information**

Type number	Package		
	Name	Description	Version
TEA5764HN	HVQFN40	plastic thermal enhanced very thin quad flat package; body $6 \times 6 \times 0.9 \text{ mm}$	SOT618-1

6. Block diagram

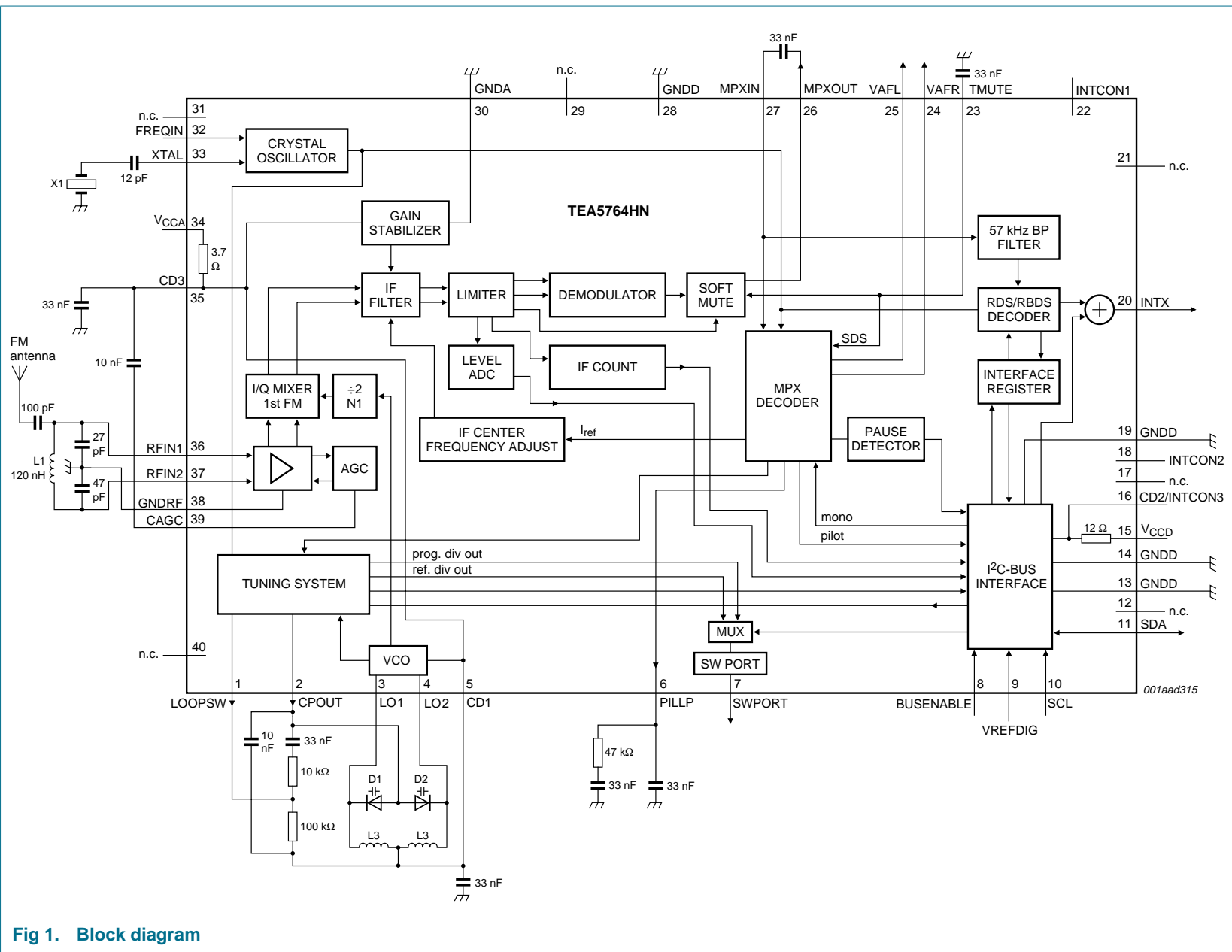
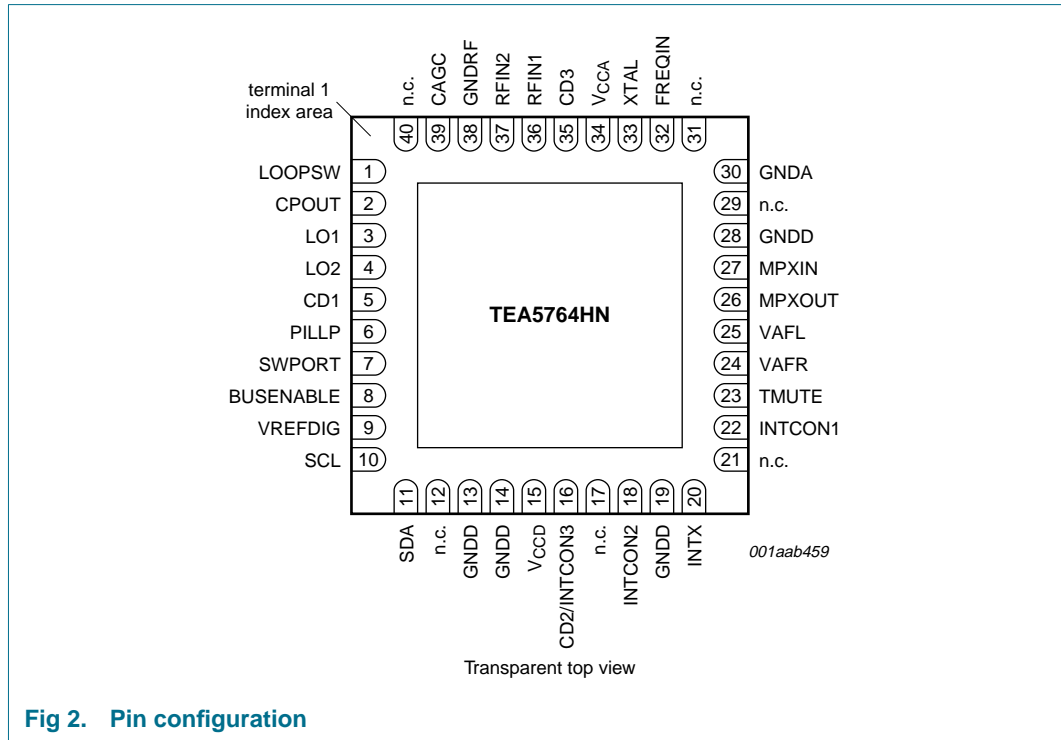

Fig 1. Block diagram

## 7. Pinning information

### 7.1 Pinning



### 7.2 Pin description

Table 3: Pin description

Symbol	Pin	Description
LOOPSW	1	synthesizer PLL loop filter switch output
CPOUT	2	charge pump output of synthesizer PLL
LO1	3	local oscillator coil connection 1
LO2	4	local oscillator coil connection 2
CD1	5	VCO supply decoupling capacitor
PILLP	6	pilot PLL loop filter
SWPORT	7	software programmable port output
BUSENABLE	8	I <sup>2</sup> C-bus enable input
VREFDIG	9	digital reference voltage for I <sup>2</sup> C-bus signals
SCL	10	I <sup>2</sup> C-bus clock line input
SDA	11	I <sup>2</sup> C-bus data line input and output
n.c.	12	not connected
GNDD	13	digital ground
GNDD	14	digital ground
V <sub>CCD</sub>	15	digital supply voltage
CD2/INTCON3	16	internally connected

Table 3: Pin description ...continued

Symbol	Pin	Description
n.c.	17	not connected
INTCON2	18	internally connected; leave open
GNDD	19	digital ground
INTX	20	interrupt flag output
n.c.	21	not connected
INTCON1	22	internally connected; leave open
TMUTE	23	soft mute time-constant capacitor
VAFR	24	right audio output
VAFL	25	left audio output
MPXOUT	26	FM demodulator MPX output
MPXIN	27	MPX decoder and RDS decoder MPX input
GNDD	28	digital ground; this pin has an internal pull-down resistor of 10 k $\Omega$ to ground
n.c.	29	not connected
GNDA	30	analog ground
n.c.	31	not connected
FREQIN	32	32.768 kHz reference frequency input
XTAL	33	crystal oscillator input
V <sub>CCA</sub>	34	analog supply voltage
CD3	35	V <sub>CCA</sub> decoupling capacitor
RFIN1	36	RF input 1
RFIN2	37	RF input 2
GNDRF	38	RF ground
CAGC	39	RF AGC time-constant capacitor
n.c.	40	not connected

## 8. Functional description

### 8.1 Low noise RF amplifier

The LNA input impedance together with the LC RF input circuit defines an FM band filter. The gain of the LNA is controlled by the RF AGC circuit.

### 8.2 FM I/Q mixer

FM quadrature mixer converts FM RF (76 MHz to 108 MHz) to IF.

### 8.3 VCO

The varactor tuned LC VCO provides the Local Oscillator (LO) signal for the FM quadrature mixer. The VCO frequency range is 150 MHz to 217 MHz.

## 8.4 Crystal oscillator

The crystal oscillator can operate with a 32.768 kHz clock crystal. The oscillator can be overridden via the FREFIN pin. When the FREFIN pin is used the oscillator is clocked externally by a 32.768 kHz signal. Selection between a reference clock or a reference crystal can be done via the I<sup>2</sup>C-bus. When a crystal is connected the FREFIN pin must be left open-circuit, and when pin FREFIN is used a crystal may not be connected. It is not possible to connect a crystal and apply a frequency via the FREFIN pin in the same application.

The crystal oscillator generates the reference frequency for the following:

- Reference frequency divider for synthesizer PLL
- Timing for the IF counter
- Timing for the pause detector
- Free running frequency adjustment of the stereo decoder VCO
- Centre frequency for adjustment of the IF filters
- Clock frequency of the RDS/RBDS decoder

## 8.5 PLL tuning system

The PLL synthesizer tuning system is suitable to operate with a 32.768 kHz reference frequency generated by the crystal oscillator or a reference clock of 32.768 kHz fed into the TEA5764HN. To tune the radio to the required frequency requires the PLL word to be calculated and then programmed to the register. The PLL word is 14 bits long; see [Table 20](#) and [Table 21](#). Calculation of this 14-bit word can be done as follows.

Formula for high-side injection:

$$N_{DEC} = \frac{4 \times (f_{RF} + f_{IF})}{f_{ref}} \quad (1)$$

Formula for low-side injection:

$$N_{DEC} = \frac{4 \times (f_{RF} - f_{IF})}{f_{ref}} \quad (2)$$

where:

$N_{DEC}$  = decimal value of PLL word

$f_{RF}$  = wanted tuning frequency (Hz)

$f_{IF}$  = intermediate frequency of 225 kHz

$f_{ref}$  = the reference frequency of 32.768 kHz

Example for receiving a channel at 100.1 MHz:

$$N_{DEC} = \frac{4 \times (100.1 \times 10^6 + 225 \times 10^3)}{32768} = 12246.704 \quad (3)$$

The result found using [Equation 1](#) or [Equation 2](#) must always be rounded to the lowest integer value. If rounded down to the lowest integer value of  $N_{DEC} = 12246$ , the PLL word becomes 2FD6h.

This value can be written to register FRQSETLSB or FRQSETMSB via the I<sup>2</sup>C-bus and the IC will then either start an autonomous search at this frequency or go to a preset channel at this frequency. When the application is built according to the block diagram shown in [Figure 1](#), and with the preferred components, the PLL will settle to the new frequency within 5 ms. The most accurate tuning is accomplished when a search is followed by a preset to the same frequency.

The PLL is triggered by writing to any one of the bytes FRQSETMSB, FRQSETLSB, TNCTRL1, TNCTRL2, TESTBITS, TESTMODE.

Accurate validation of the PLL locking on the new frequency can take 2 ms to 10 ms. When a lock is detected, bit LD is set.

## 8.6 Band limits

The TEA5764HN can be switched either to the Japanese FM-band or to the US/Europe FM-band. Setting bit BLIM to logic 0 the band range is 87.5 MHz to 108 MHz; setting bit BLIM to logic 1 selects the Japanese band range of 76 MHz to 90 MHz.

## 8.7 RF AGC

The RF AGC (or wideband AGC) prevents overloading and limits the amount of intermodulation products created by strong adjacent channels. The RF AGC is on by default and can be turned off via the I<sup>2</sup>C-bus.

The TEA5764HN also has an in-band AGC to prevent overloading by the wanted channel. The in-band AGC is always turned on.

## 8.8 Local or long distance receive

If bit LDX = 1, the LNA gain is reduced by 6 dB to prevent distortion when a transmitter is very near. If bit LDX = 0, the LNA gain is normal to receive long distance (DX) stations.

## 8.9 IF filter

A fully integrated IF filter is built-in.

## 8.10 FM demodulator

The FM quadrature demodulator has an integrated resonator to perform the phase shift of the IF signal.

## 8.11 IF counter

The received signal is mixed to produce an IF of 225 kHz. The result of the mixing is counted. A good IF count result indicates that the radio is tuned to a valid channel instead of an image or a channel with much interference. The IF counter outputs a 7-bit count result via the I<sup>2</sup>C-bus. The IF counter is continuously active and can be read at any time via the I<sup>2</sup>C-bus. It also activates a flag when the IF count result is outside the IF count valid result window; see [Section 9.1.4.4](#).



Before a tuning cycle is initiated the IF count period can be set to 2 ms or to 15.6 ms by bit IFCTC. When the IF count period is set to 2 ms, initiating the tuning algorithm with a preset (bit SM = 0) will always give an RDS update as shown in [Section 8.22.1](#). In case the IF count time is set to 15.6 ms, the tuning flowchart illustrated in [Figure 3](#) is used. Once tuned, the IF count period is always 15.6 ms.

## 8.12 Voltage level generator and analog-to-digital converter

The voltage level indicates the field strength received by the antenna. The voltage level is analog-to-digital converted to a 4-bit word and output via the I<sup>2</sup>C-bus. The ADC level is continuously active and can be read at any time via the I<sup>2</sup>C-bus. It also activates a flag when the voltage level falls below a predefined selectable threshold. Bit LHSW allows either large or small hysteresis steps to be chosen; see [Table 24](#) and [Section 9.1.4.5](#).

When the ADC level is set to 3, its minimum value, the search algorithm will only stop at channels having a RF level higher than, or equal to, ADC level 3. After completing the search algorithm and being tuned to a station, due to hysteresis the effective limit will be set to 0. This means that the continuous ADC level check will never set the LEVFLAG.

## 8.13 Mute

### 8.13.1 Soft mute

The low-pass filtered voltage level drives the soft mute attenuator at low RF input levels: the audio output is faded and hence also the noise (see [Figure note 1](#) in [Figure 15](#) and [Figure 17](#)).

The soft mute function can also be switched off via the I<sup>2</sup>C-bus, using bit SMUTE.

### 8.13.2 Hard mute

The audio outputs VAFL and VAFR can be hard-muted by bit MU in byte TNCTRL2, which means that they are put into 3-state. This can also be done by setting bits Left Hard Mute (LHM) or Right Hard Mute (RHM) in byte TESTBITS, which allows either one or both channels to be muted and forces the TEA5764HN to mono mode. When the TEA5764HN is in Standby mode the audio outputs are hard-muted.

### 8.13.3 Audio frequency mute

The audio signal is muted by setting bit AFM of the TNCTRL1 register to logic 1. In the soft mute attenuator the audio signal is blocked and so pins VAFL and VAFR will be at their DC biasing point with no signal.

The audio is automatically muted during an RDS update as shown in the flowchart of [Figure 3](#). When the audio must be muted during Search mode, it is done by setting bit AFM to logic 1 before the search action and resetting it to logic 0 afterwards.

Setting bit AFM to logic 0 stops the RDS data.

## 8.14 MPX decoder

The PLL stereo decoder is adjustment free. It can be switched to mono via the I<sup>2</sup>C-bus.

### 8.15 Signal dependent mono/stereo blend (stereo noise cancellation)

If the RF input level decreases, the MPX decoder blends from stereo to mono to limit the output noise. The continuous mono-to-stereo blend can also be programmed via the I<sup>2</sup>C-bus to an RF level dependent switched mono-to-stereo transition. Stereo noise cancellation can be switched off via the I<sup>2</sup>C-bus by bit SNC.

### 8.16 Software programmable port

One software programmable port (CMOS output) can be addressed via the I<sup>2</sup>C-bus:

Bit SWPM = 1, the software port functions as the output for the FRRFLAG.

Bit SWPM = 0, the software port outputs bit SWP of the registers.

In Test mode the software port outputs signals according to [Table 27](#). Test mode is selected, setting bit TM of byte TESTMODE to logic 1.

The software port cannot be disabled by the PUPD bits; see [Section 8.17](#).

### 8.17 Standby mode

The radio can be put into Standby mode by the Power-Up / Power-Down (PUPD) bits. The RDS part can be turned off separately or both the RDS and the FM part can be turned off. The TEA5764HN is still accessible via the I<sup>2</sup>C-bus but takes only a low power from the supply, in Standby mode, the audio outputs are hard-muted.

### 8.18 Power-on reset

After startup of  $V_{CCA}$  and  $V_{CCD}$  a power-on reset circuit will generate a reset pulse and the registers will be set to their default values. The power-on reset is effectively generated by  $V_{CCD}$ .

After a power-on reset the TEA5764HN is in Standby mode and the PUPD bits are set to logic 0. After a power-on reset the registers are reset to their default value, except for byte12R to byte19R and flags DAVFLAG, LSYNCFLAG and PDFLAG. To reset these, the RDS part must be turned on by setting PUPD. After setting PUPD to logic 1, it will take 0.9 ms to start-up the TEA5764HN and set these registers to their default value.

The power supplies can be switched on in any order.

When the supply voltage  $V_{CCA}$  and  $V_{CCD}$  are at 0 V, all I/Os, the audio outputs and the reference clock input are high-ohmic.

### 8.19 RDS/RBDS

#### 8.19.1 RDS/RBDS demodulator

A fully integrated RDS/RBDS demodulator which uses the reference frequency (32.678 Hz) of the PLL synthesizer tuning system. The RDS demodulator recovers and regenerates the continuously transmitted RDS or RBDS data stream of the multiplex signal (MPXRDS) and provides the signals clock (RDCL), data (RDDA) for further processing by the integrated RDS decoder.

## 8.19.2 RDS data and clock direct

The RDS demodulator retrieves the RDS data and clock signals, this data can be put directly onto pins VAFL and VAFR by setting bit RDSCDA to logic 1.

### 8.19.2.1 RDS/RBDS decoder

The RDS decoder provides block synchronization, error correction and flywheel function for reliable extraction of RDS or RBDS block data. Different modes of operation can be selected to fit different application requirements. Availability of new data is signalled by bit DAVFLG and output pin INTX which generates an interrupt. Up to two blocks of data and status information are available via the I<sup>2</sup>C-bus in a single transmission.

The behavior of the DAVFLG is described in [Section 10](#).

## 8.20 Audio pause detector

The audio pause detector monitors the audio modulation for pauses and responds to low levels. The modulation threshold can be adjusted in 4 steps of 4 dB by control bits PL[1:0]. The minimum time for detecting a pause can be adjusted by control bits PT[1:0] as shown in [Table 38](#). When a pause occurs, flag PDFLAG is set to logic 1 and a hardware interrupt is generated; see [Section 9.1.4.6](#).

## 8.21 Auto search and Preset mode

In Search mode the TEA5764HN can search channels automatically; see [Figure 3](#).

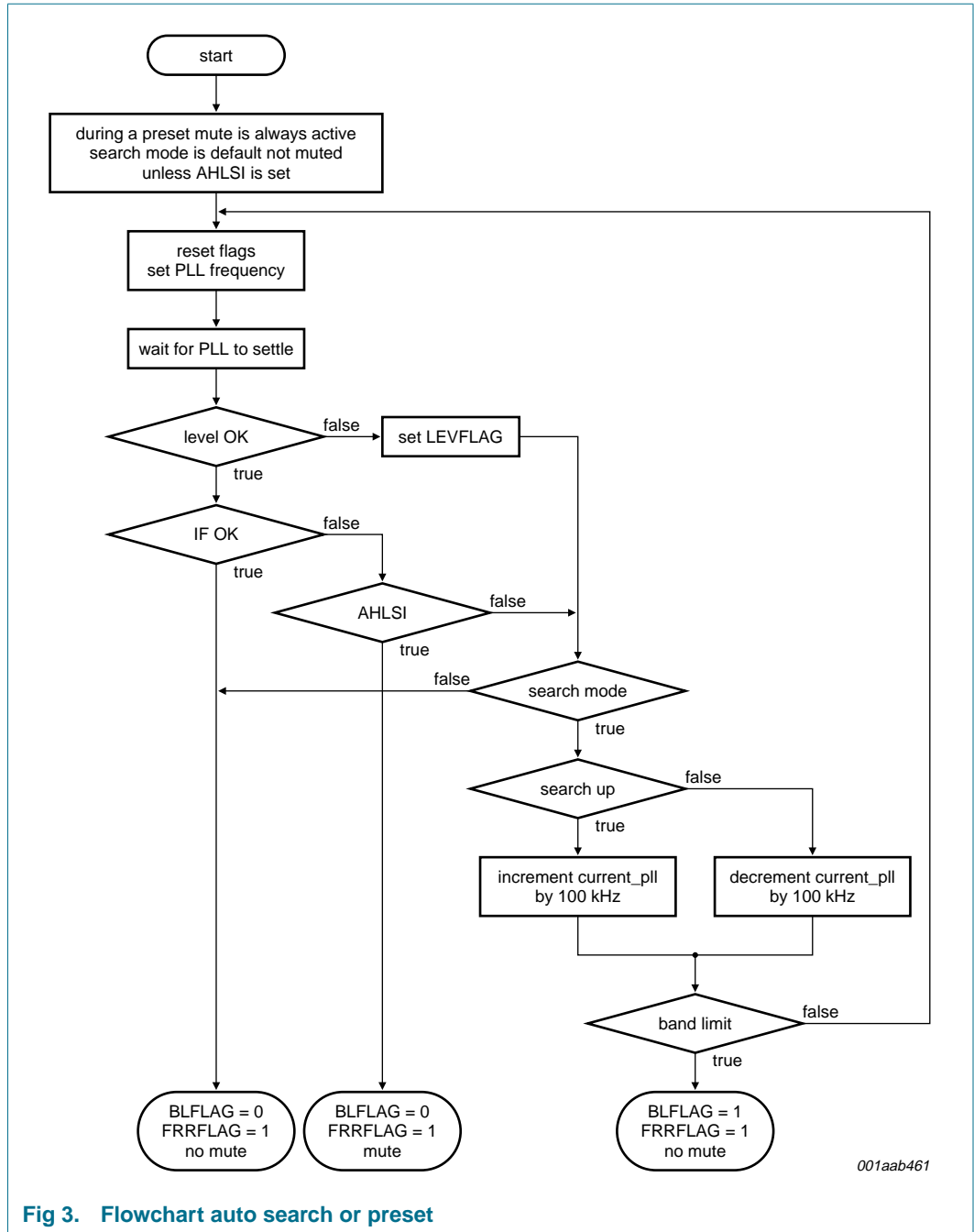

**Fig 3. Flowchart auto search or preset**

Before starting a search or a preset, the INTMSK register must be reset and only the FRRMSK must be set. This allows the microprocessor to be interrupted only when the search or preset algorithm is ready.

### 8.21.1 Search mode

Search mode is initiated by setting bit SM in byte FRQSETMSB to logic 1. The search direction is set by bit SUD; SUD = 0 (search down), bit SUD = 1 (search up). The tuner starts searching at the frequency set in bytes FRQSETLSB and FRQSETMSB. The Search Stop Level (SSL) bits define the field strength level at which a desired channel is detected. The tuner will stop on a channel with a field strength equal to or higher than this reference level and then checks the IF frequency; when both are valid, the search stops (Note that this depends on bit AHLSI described in [Figure 3](#)). If the level check or the IF count fails, the search continues. If no channels are found, the TEA5764HN stops searching when it has reached the band limit, setting the BLFLAG HIGH. A search always stops when the FRRFLAG is set and on the occurrence of a hardware interrupt, this procedure is shown in [Figure 3](#).

The search algorithm can stop at a frequency that is offset from the IF by up to a maximum of 12 kHz. The maximum offset can be limited to 8 kHz by applying a preset. For optimum tuning, it is recommended that a preset is applied after a search and when the found frequency has an offset that is above 8 kHz.

After this interrupt the TEA5764HN will not update the tuner registers for a period of 15 ms. The state of the TEA5764HN can be checked by reading the bytes of INTFLAG, FRQCHKMSB, FRQCHKLSB, TNCTRL1 and TNCTRL2. [Table 4](#) shows the possible states of these registers after an auto search.

**Table 4:** Tuner truth table [\[1\]](#)

IFFLAG	BLFLAG	FRRFLAG	Comment
0	0	0	if pin INTX has gone LOW and only IFMSK, FRRMSK and BLMSK were set then this cannot occur
0	0	1	channel found during search / preset; FRRMSK set
0	1	0	not a valid state
0	1	1	a valid channel found and the band limit has been reached during a search; BLMSK or FRRMSK set
1	0	0	not a valid state
1	0	1	a preset or search has occurred but the wanted channel has a valid RSSI level but fails the IF count when AHLSI was set to logic 1; HLSI must be toggled and a new PLL value must be programmed; FRRMSK set
1	1	0	not a valid state
1	1	1	band limit is reached during search; no valid channel found; BLMSK or FRRMSK set

[1] This table is valid until 30.6 ms after the tuning cycle has completed. It shows the outcome of the flag register when a read is done after pin INTX goes LOW on condition that no mask bit other than FRRMSK is set.

### 8.21.2 Preset mode

A preset occurs by setting bit SM to logic 0 and writing a frequency to byte FRQSETMSB. The tuner jumps to the selected frequency and sets the FRRFLAG when it is ready.

After this interrupt the TEA5764HN will not update the tuner registers for a period of 15 ms. The state of the TEA5764HN can be checked by reading registers: INTFLAG, FRQCHKLSB, FRQCHKMSB, TNCTRL1 and TNCTRL2. [Table 4](#) shows the possible states after a preset.

### 8.21.3 Auto high-side and low-side injection stop switch

When a channel is searched or a preset is done, reception can sometimes improve when injection is done at the other side of the wanted channel.

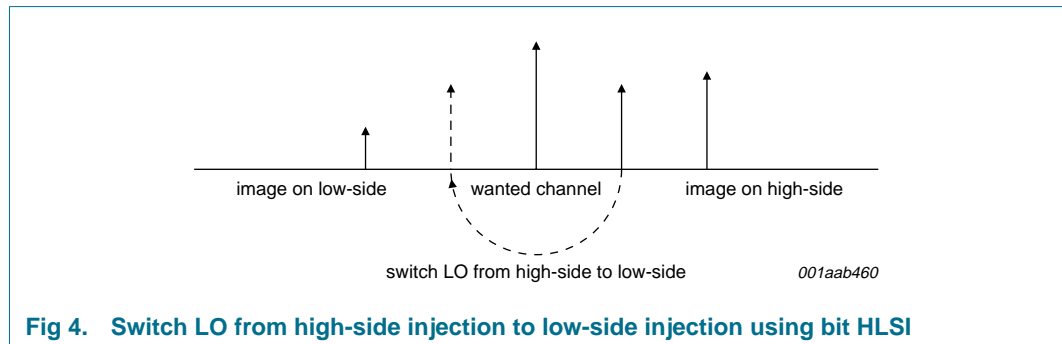

Fig 4. Switch LO from high-side injection to low-side injection using bit HLSI

The TEA5764HN has bit HLSI which toggles the injection of the local oscillator from high-side (bit HLSI = 1) to low-side (bit HLSI = 0). When bit HLSI is toggled, a new PLL setting must be sent to the TEA5764HN.

When bit AHLSI is set to logic 1, the search / preset algorithm will stop after a channel has a valid RSSI level check but fails the IF count. The microprocessor can now respond by toggling the HLSI switch and sending a new PLL value to the tuner.

### 8.21.4 Muting during search or preset

During a preset the tuner is always muted and this is implemented by the algorithm.

A search is not muted by default unless bit AFM = 1 or bit AHLSI = 1.

When bit AHLSI = 1 and the tuner stopped during a preset or a search because of a wrong IF count, the tuner stays muted; this allows the microprocessor to switch from the high to low setting quietly and wait for the new result.

The tuner is always muted if bit AFM = 1 and is independent of a search or a preset. A search can be muted by setting bit AFM to logic 1 before a search is initiated and resetting it to logic 0 when the tuner is ready (only set bit FRRMSK when initiating a search or preset).

All these mute actions are done by blocking the audio signal inside the soft mute attenuator, the audio output will keep its DC level and stay low-ohmic i.e. 50  $\Omega$  (a hard mute set by bit MU will cause a pop).

## 8.22 RDS update/alternative frequency jump

A channel which transmits RDS data can have alternative channels which have the same information. These alternative channel frequencies are in the RDS data, so the microprocessor can read the alternative frequencies and store them in a memory.

The tuner can perform an RDS update. This is very similar to a preset, but with a 2 ms IF count time. The tuner will jump to the alternative frequency and check the level and the IF count using a 2 ms count time. When the RSSI level check is above the specified level and the IF count result is within the limits, then the tuner will stay at the alternative frequency and stay muted, the microprocessor can now decide what to do. If the alternative frequency is not valid it will jump back to the frequency it came from.

The algorithm will finish with the FRRFLAG being set and an interrupt is generated. After this interrupt the TEA5764HN will not measure the IF count for a period of 15 ms. 15 ms after completing a RDS jump, a measurement of the IF count will start and hence the IF count result and the IFFLAG will be updated 30.6 ms after completing the algorithm. The level measurement will start immediately after the tuning algorithm, so the LEVFLAG will be updated 500  $\mu$ s after the algorithm. The state of the TEA5764HN can be checked by reading registers INTFLAG, FRQCHKLSB, FRQCHKMSB, IFCHK and LEVCHK. [Table 5](#) shows the possible states after an auto search, [Figure 5](#) shows how the RDS is updated.

### 8.22.1 Muting during RDS update

An RDS update (AF jump) is always muted. There are two possibilities for leaving the algorithm:

- The tuner jumps to an alternative frequency which is not valid (according to the specified SSL limit and fixed IF counter limits) and jumps back, then it will automatically unmute
- Or the tuner jumps to a valid alternative frequency and stays there. Now it does not unmute. The microprocessor can unmute or it keeps the tuner muted and can check for the presence of RDS data. The valid way to unmute is to apply a preset to the current frequency (an IF count time of 15.6 ms is used at preset, which gives a more accurate IF count result than the result obtained by the AF jump, where 2 ms is used)

**Table 5:** RDS update truth table<sup>[1]</sup>

IFFLAG	BLFLAG	FRRFLAG	Comment
0	0	0	if pin INTX is LOW and only IFMSK, FRRMSK and BLMSK were set then this cannot occur
0	0	1	alternative frequency jump successful; radio is tuned to the alternative frequency and stays muted
0	1	0	not a valid state
0	1	1	not a valid state
1	0	0	not a valid state
1	0	1	AF jump has occurred but the wanted channel fails the IF count; the PLL will be set back to the old value
1	1	0	not a valid state
1	1	1	if pin INTX is LOW and only IFMSK, FRRMSK and BLMSK were set then this cannot occur

[1] This table is valid until 30.6 ms after an RDS update has completed. It shows the outcome of the flag register when a read is done after pin INTX has gone LOW and on condition that only mask bit FRRMSK is set.

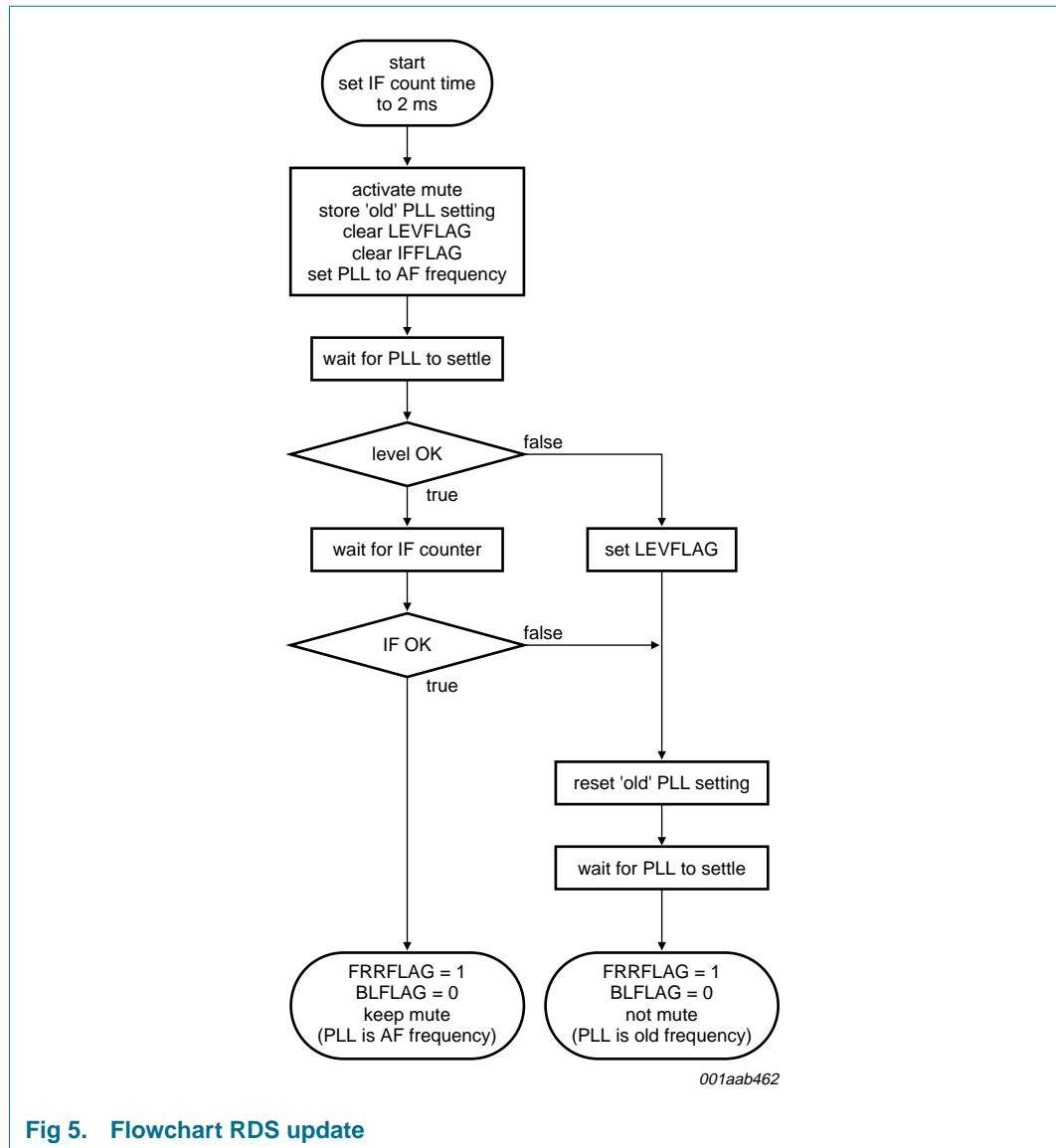

Fig 5. Flowchart RDS update

## 9. Interrupt handling

### 9.1 Interrupt register

The first two bytes of the I<sup>2</sup>C-bus register contain the interrupt masks and the interrupt flags. A flag is set when it is a logic 1.

Table 6: INTFLAG - byte0R

Bit	7	6	5	4	3	2	1	0
Symbol	DAVFLG	TESTBIT	LSYNCF LG	IFFLAG	LEVFLAG	PDFLAG	FRRFLAG	BLFLAG

Table 7: INTMSK - byte0W / byte1R

Bit	7	6	5	4	3	2	1	0
Symbol	DAVMSK	-	LSYNCMSK	IFMSK	LEVMSK	PDMSK	FRRMSK	BLMSK



The interrupt flag register contains the flags set according to the behavior outlined in [Section 9.1.4](#). When these flags are set they can also cause the INTX to go active (hardware interrupt line) depending on the status of the corresponding mask bit in [Table 7](#). A logic 1 in the mask register enables the hardware interrupt for that flag.

Hence, it is conceivable that, with all the mask bits cleared, the software could operate in a continuous polling mode that reads the interrupt flag register for any bits that maybe set.

Interrupt mask bits are always cleared after reading the first two bytes of the interrupt register. This is to control multiple hardware interrupts (see [Figure 6](#)). Bit LSYNCMSK has a different function and is not cleared after reading the interrupt register bytes; see also [Section 9.1.4.3](#).

### 9.1.1 Interrupt clearing

The interrupt flag and mask bits are always cleared after:

- They have been read via the I<sup>2</sup>C-bus
- A power-on reset

### 9.1.2 Timing

The timing sequence for the general operation interrupts is shown in [Figure 6](#) and shows a read access of the interrupt bytes INTFLAG and INTMSK and a subsequent (though not necessarily immediate) write to the mask register. It also indicates the two key timing points A and B.

If an interrupt event occurs while the register is being accessed (after point A) it must be held until after the mask register is cleared at the end of the read operation (point B).

Point A is after the R/W bit has been decoded and point B is where the acknowledge has been received from the master after the first two bytes have been sent.

The LOW time for the INTX line ( $t_{LOW}$ ) has a maximum value specified in [Section 15](#). However it can be shorter if the read of the INTMSK and INTFLAG bytes occurs within  $t_{LOW}$ .

### 9.1.3 Reset

A reset can be performed at any time by a simple read of the interrupt bytes, byte0R and byte0W, which automatically clears the interrupt flags and masks.

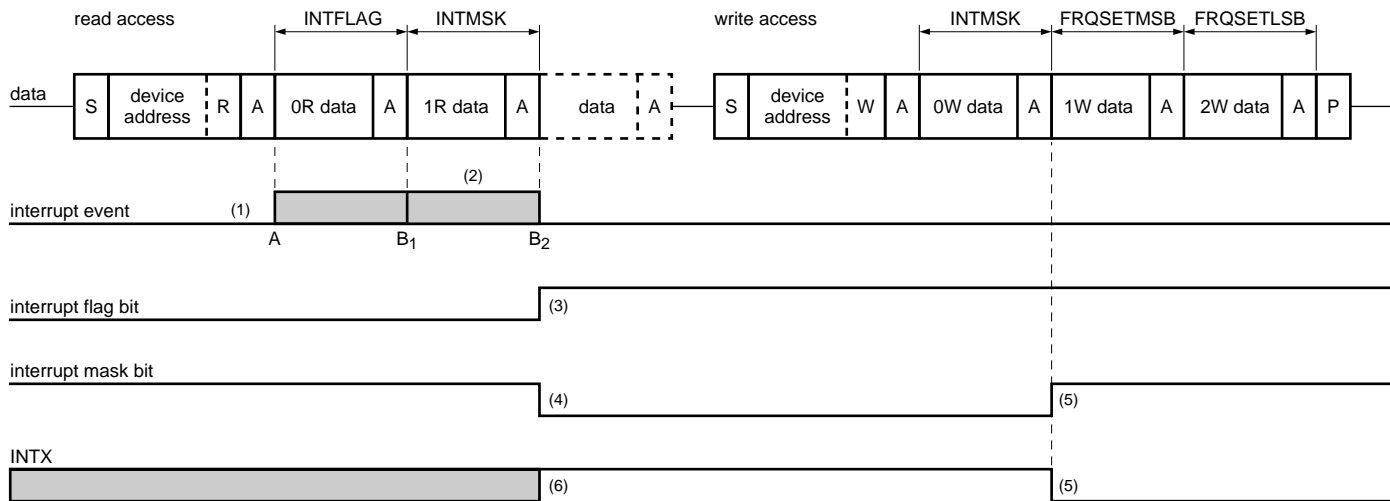

001aab464

- (1) Interrupt events that occur outside of the region A-B set their respective flag bits in the normal way immediately and can thus trigger a hardware interrupt if the mask bits are set.
- (2) The blocking of interrupts is marked by the region A-B<sub>1</sub> / B<sub>2</sub> depending on the actual read cycle.  
B<sub>1</sub> is when only the INTFLAG is read and a stop condition is received (only INTFLAG is read so only this will be cleared).  
B<sub>2</sub> is when both registers are read and hence cleared and this is terminated by either an acknowledge or stop bit.
- (3) Interrupt events that occur between A and B set their respective flags after the mask bits are cleared. Which means that in this diagram an interrupt event occurred in period A-B, so after A-B the flag goes to logic 1.
- (4) All interrupt mask bits are cleared after the interrupt flag and mask bytes are read.
- (5) Software writes to the mask byte and enables the required mask bits. Any flags currently set will then trigger a hardware interrupt.
- (6) INTX is set HIGH (inactive) after the interrupt mask bytes are read.

Fig 6. I<sup>2</sup>C-bus interrupt sequence, read and write operation

## 9.1.4 Interrupt flags and behavior

### 9.1.4.1 Multiple interrupt events

If the interrupt mask register bit is set then the setting of an interrupt flag for that bit causes a hardware interrupt (pin INTX goes LOW). If the event occurs again, before the flag is cleared, then this does not trigger any further hardware interrupts until that specific flag is cleared. However, two different events can occur in sequence and generate a sequence of hardware interrupts. A second interrupt can be generated only after the INTMSK byte is read, followed by a write as the first interrupt blocks the input of the INTX one-shot generator.

If subsequent interrupts occur within the INTX LOW period then these do not cause the INTX period to extend beyond its specified maximum period (see [Section 9.2](#)).

### 9.1.4.2 Data available flag

The DAVFLG is set when a new block of data is received according to [Figure 9](#) to [Figure 12](#), where the different DAV modes are described. Once synchronized, this continues for all subsequent received blocks (dependent on DAV mode) and in the following situations:

- During sync search, in any DAV mode: two valid blocks in the correct sequence received with BBC < BBL (synchronized).
- During synchronization search in DAVB mode if a valid A(C')-block has been detected. This mode can be used for fast search tuning (detection and comparison of the PI code contained in the A or C' block).
- If the pre-processor is synchronized and in mode DAVA and DAVB a new block has been processed. This mode is the standard data processing mode if the decoder is synchronized.
- If the pre-processor is synchronized and in DAVC mode, two new blocks have been processed.
- If the decoder is synchronized and in any DAV mode, with LSYNCMSK = 0, loss of synchronization is detected (flywheel loss of synchronization, resulting in a restart of synchronization search).

The DAVFLG is reset by a read of RDSLBSB (byte15R) or RDSPBSB (byte17R). An interrupt is asserted each time a new block of data is decoded and when bit DAVMSK is set; see [Section 10](#).

### 9.1.4.3 RDS synchronization flag

Bit SYNC, [Table 29](#), shows the status of the RDS decoder. If it is a logic 1 then the decoder is synchronized, if it is a logic 0 it is not.

The action of the TEA5764HN depends on the status of bit LSYNCMSK in [Table 7](#). If this is set then the loss of synchronization causes bit LSYNCFL to go to logic 1 when synchronization is lost, and a hardware interrupt is asserted. The RDS part of the TEA5764HN is set to idle and waits for the microprocessor to initiate a new synchronization search by setting bit NWSY as described in [Table 36](#).

If bit LSYNCMSK is 0 and synchronization is lost, the ASIC automatically starts a new synchronization search. It will not generate a hardware interrupt. The microprocessor can wait until the RDS decoder is synchronized again, this will be indicated by the DAVFLG and the SYNC status bit (this requires bit DAVMSK being set).

Bit LSYNCFL is reset by a read of the INTMSK byte1R.

Bit LSYNCMSK is not reset by a read of byte INTMSK, it must be set or reset by the microprocessor. Resetting it automatically would change the status of the ASIC and cause an automatic synchronization search as described above.

How the synchronization is defined is explained in brief in [Section 10](#).

#### 9.1.4.4 IF frequency flag

During an automatic frequency search, preset or AF update, the FM part of the TEA5764HN performs a check of the received IF frequency as a measure of the level of interference in the channel received. If an incorrect IF frequency is received, it indicates the presence of either strong interferers or tuning to an image which sets bit IFFLAG in the INTFLAG register. Also a preset to a channel with no signal will result in a wrong IF count value and hence the setting of bit IFFLAG.

When a search, preset or AF update is finished, bit FRRFLAG will be set to indicate this and will generate an interrupt. The microprocessor can now read the outcome of the registers which will contain the IF count value and the IFFLAG status of the channel it is tuned to. In the case of an AF update, the IF count value of the alternative frequency will be in the registers and also when it jumps back, because it will then not start a new IF count.

15 ms after the tuning algorithm has completed the IF counter will start a new count. So 30.6 ms after a failed AF update the IF count result will be equal again to that of the channel from where the jump was initiated.

15 ms after the FRRFLAG has been set the IF counter will start to run continuously on the tuned frequency and if the conditions for correct frequency are not met then this sets bit IFFLAG in the interrupt register. When bit IFMSK is set this will also cause an interrupt.

Bit IFFLAG is cleared by a read of byte1R, or by starting the tuning algorithm.

#### 9.1.4.5 RSSI threshold flag

The voltage level reflects the field strength received by the antenna. The voltage level is analog to digital converted to a 4-bit value and output via the I<sup>2</sup>C-bus, this 4-bit level value can be compared to a threshold level set by the SSL bits in [Table 19](#) or the LH bits in [Table 26](#).

The ADC level (which converts the analog value to digital) can be triggered to convert in either of two ways:

1. During a tuning step, a search, a preset or an AF update, it is triggered by these algorithms and compares the level with the threshold set by bits SSL[1:0]. Bit LEVFLAG is set if the RSSI level drops below the threshold level set by bits SSL[1:0]; see [Table 19](#). The hardware interrupt is only generated if the corresponding mask bit is set.

- After a search, a preset or an AF update, the threshold for comparison is switched to the hysteresis level. The hysteresis level is set by the combination of bits SSL[1:0] and bit LHSW; see [Table 24](#). The result is a hysteresis as shown in [Table 26](#). Then the ADC level starts to run automatically and compares the level every 500  $\mu\text{s}$  with the hysteresis level. Bit LEVFLAG is set if the RSSI level drops below the threshold level set by bits SSL[1:0] in combination with bit LHSW (see [Table 26](#)); the hardware interrupt is only generated if the corresponding mask bit is set. Bit LHSW allows either a small or a large hysteresis to be selected which results in the levels of the left RSSI hysteresis threshold column for bit LHSW = 0 and the right RSSI hysteresis threshold column; see [Table 26](#). When a search or preset is done with the ADC level set to 3 then when the algorithm has finished, the threshold level is set to 0. Hence the LEVFLAG will never be set.

Bit LEVFLAG is cleared by a read of the INTMSK byte1R, or by starting the tuning algorithm.

#### 9.1.4.6 Pause detection flag

The pause detector monitors the amplitude of the audio signal and starts counting if it drops below the reference level. When the counter reaches the specified count time, a pause is detected and the PDFLAG is set and will generate an interrupt if bit PDMSK is set to logic 1. The PDFLAG operates independently of bit PDMSK and is only active when the RDS decoder is switched on when bit PUPD is set to logic 1 and when the RDS decoder is not idle if synchronization is lost.

See [Figure 7](#). When the peak audio level of the (L+R) drops below the threshold level at  $t_1$  it counts the duration of the pause. If the pause lasts longer than the value set by the PT bits, bit PDFLAG is set which in turn generates a hardware interrupt (bit PDMSK set to logic 1). The threshold level at  $t_1$  is set by the PL bits shown in [Table 38](#).

Bit PDFLAG is cleared by a read of byte1R on condition that the read action occurs more than 500  $\mu\text{s}$  after receiving the pause interrupt on the INTX line.

The circuit should ignore short transients where the audio level momentarily rises above the threshold (at  $t_2$ ).

A pause is detected by comparing the amplitude of the audio signal with the reference level selected by the PL bits. The resultant signal PSCO produced by this comparison is sampled at a frequency of 2341 Hz resulting in signal PSCOn. A pause is detected under the conditions given by [Equation 4](#) and [Equation 5](#).

$$\{SUM(0toN - 1)[PSCOn = 0] - 8 \times SUM(0toN - 1)[PSCOn = 1]\} > PT \times 2341 \quad (4)$$

$$t_{pause} - 8 \times t_{audio} > PT \quad (5)$$

where N is the number of samples taken over time and PT is the pause time selected by bus bits PT. When a pause is detected, the integrator will be reset. The integrator value cannot be less than zero; therefore if in [Equation 4](#), the value of the second SUM becomes larger than the first SUM, the output of the integrator remains at zero.

Suppose that PT = 20 ms,  $t_{pause} = 16$  ms and  $t_{audio} = 1.5$  ms. The pause detector will count according to [Equation 5](#) as shown in [Equation 6](#):

$$2 \times t_{pause} - 8 \times t_{audio} = 20 \text{ ms} \geq 2 \times 16 \text{ ms} - 8 \times 1.5 \text{ ms} = 20 \text{ ms} \quad (6)$$

In [Equation 6](#), the pause detector has measured  $1 \times 16$  ms 'pause',  $8 \times 1.5$  ms 'no pause' and  $1 \times 16$  ms pause. Therefore on average the pause detector has measured  $16$  ms –  $12$  ms +  $16$  ms =  $20$  ms pause time and hence a pause will be detected.

The PSCOn signal goes directly to the software port. The PDFLAG is set by the integrator and goes to the bus. The interrupt line is triggered by the PDFLAG.

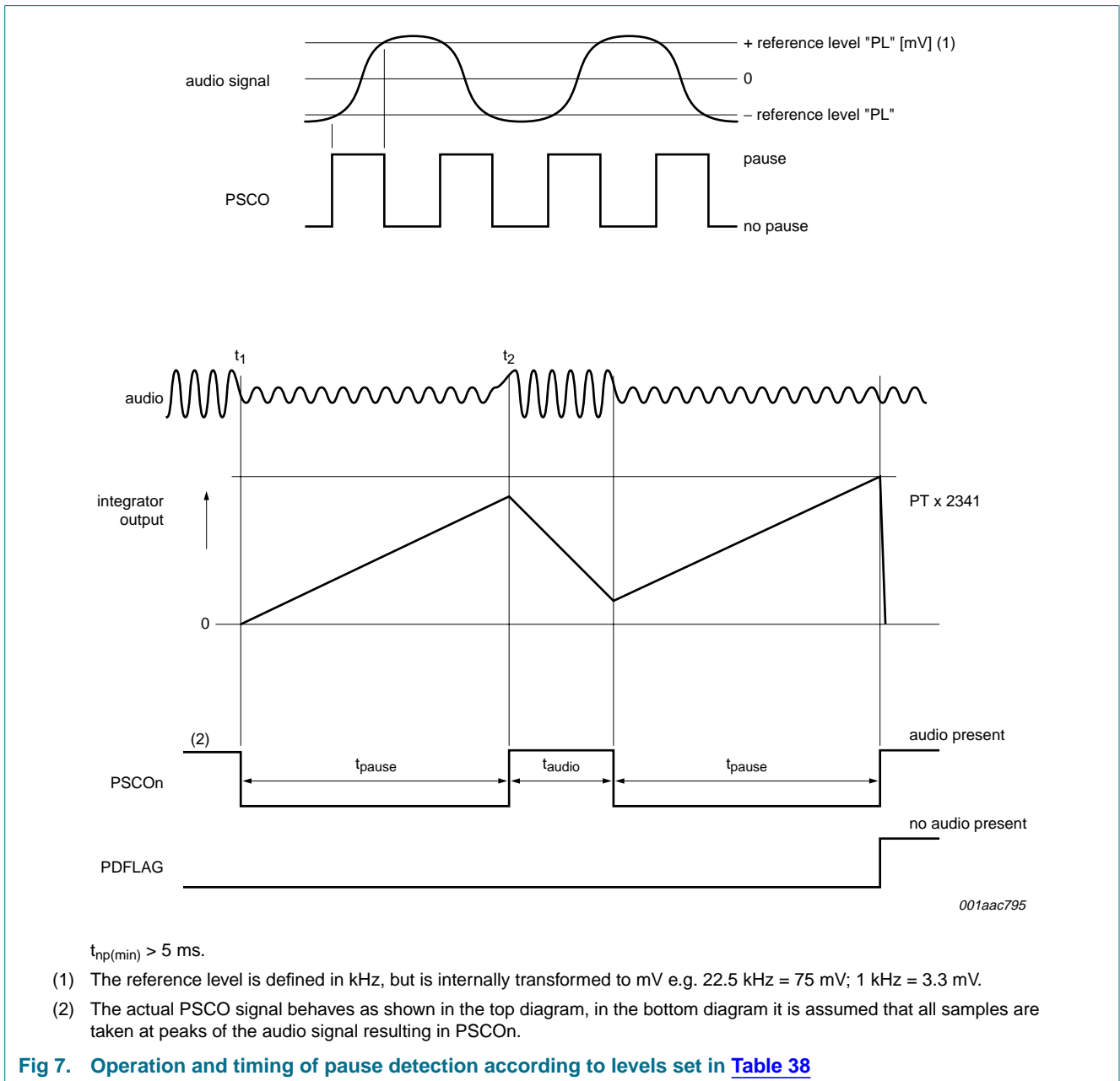

9.1.4.7 Frequency ready flag

The frequency ready flag bit is set to logic 1 when the automatic tuning has finished a search, a preset or an RDS AF update. This bit is described in [Table 4](#) and [Table 5](#). The FRRFLAG is cleared by a read of byte1R.

### 9.1.4.8 Band limit flag

The band limit bit BLFLAG is set to logic 1 when the automatic tuning has detected the end of the tuning band or when the PLL cannot lock on a certain frequency. This bit is described in [Table 4](#) and [Table 5](#). This bit is cleared by reading byte1R.

## 9.2 Interrupt output

The interrupt line driver is a MOS transistor with a nominal sink current of 680  $\mu\text{A}$ , it is pulled HIGH by an 18 k $\Omega$  resistor connected to pin VREFDIG. The interrupt line can be connected to one other similar device with an interrupt output and an 18 k $\Omega$  pull-up resistor providing a wired OR function. This allows any of the drivers to pull the line LOW by sinking the current. When a flag is set and not masked it generates an interrupt; see [Figure 8](#).

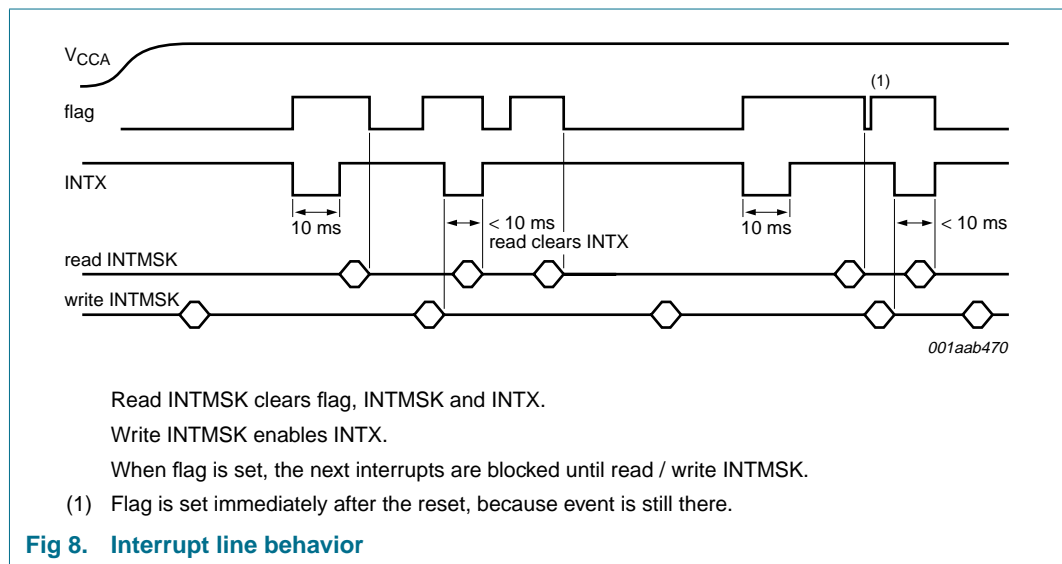

**Fig 8. Interrupt line behavior**

## 10. RDS data processing

The RDS demodulator and decoder perform the following operations:

- Demodulation of the RDS/RDBS data stream from the MPX signal
- Symbol decoding
- Block and group synchronization
- Error detection and correction
- Store last and previous data block received with associated ID and error status
- Set the DAVFLG when new data is received
- Set the SYNC status bit according to the current synchronization state
- Set the LSYNCFL flag when synchronization is lost

The RDS decoder can be set to different modes, each meant to look for specific information.

## 10.1 DAV-A processing mode

The DAV-A processing mode is the standard processing mode used. In this mode, when a data block has been decoded, it is transferred to the I<sup>2</sup>C-bus registers. It generates interrupts on the INTX line after every new block of RDS data that has been processed and also sets the DAVFLG; see [Figure 9](#). The DAVFLG is reset by a read of the I<sup>2</sup>C-bus registers.

If a data block is decoded and a new one arrives, pin INTX goes LOW again, the DAVFLG will be set and the last block will be shifted to the previous block and the last decoded block will be put in the last block. This means that all RDS data is still available in the BL and BP registers.

When the I<sup>2</sup>C-bus registers are not read the DAVFLG will not be reset. If a data block is decoded and a new one arrives, pin INTX goes LOW and the last block will be shifted to the previous block and the last decoded block will be put in the last block. This means that all RDS data is still available in the BL and BP registers but must be read. This is indicated by the setting of bit DOVF.

If the I<sup>2</sup>C-bus registers are still not read, data will be lost, except when this read is done within 20 ms after the INTX line has gone LOW and 2 ms before the arrival of a new block. If this read is done at least 2 ms before the arrival of a new block, then BL and BP are read and the data in the decoder buffer is then instantaneously shifted to the BL register. All data is now read and bit DOVF will be reset.



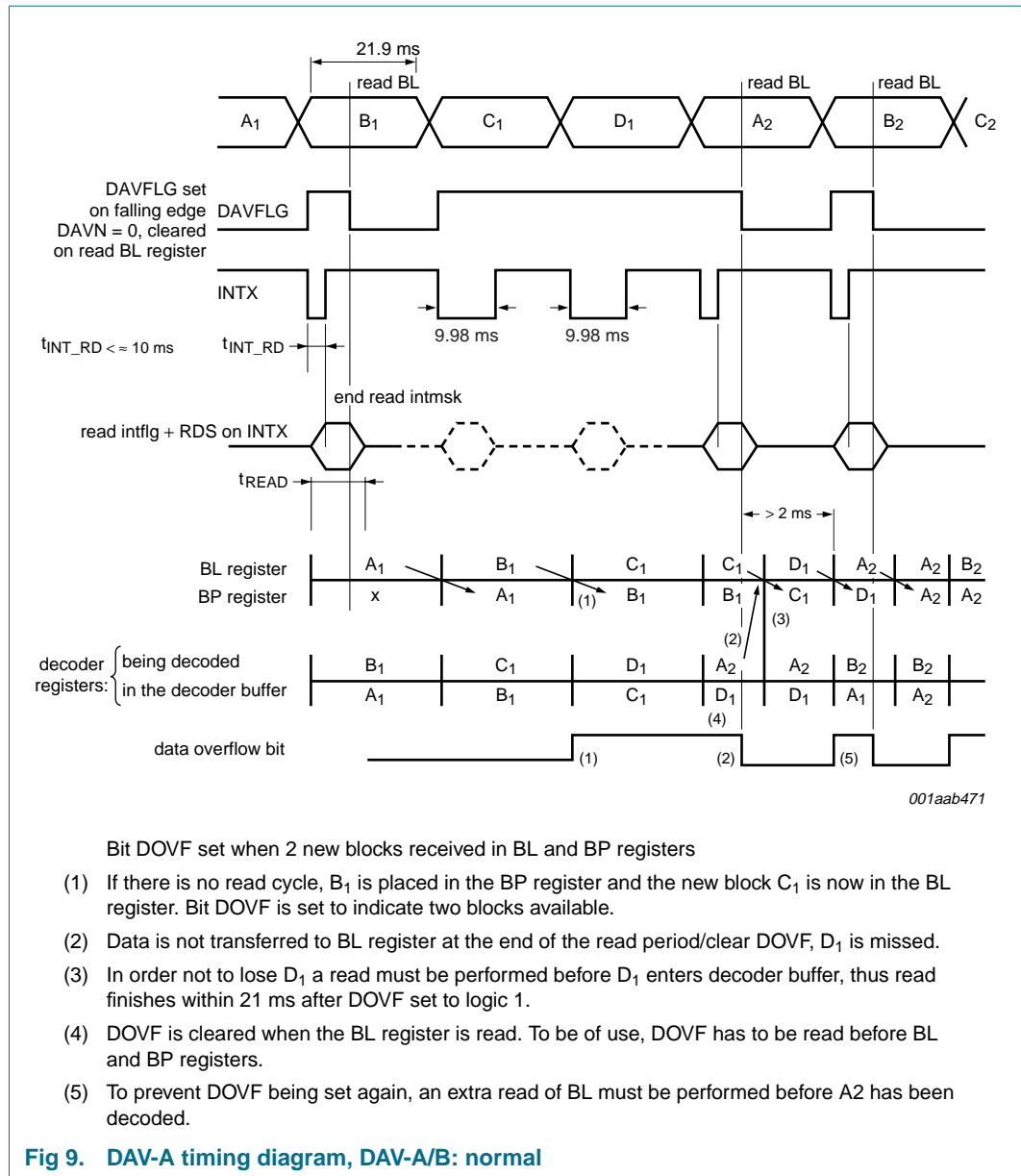

Figure 9 assumes that block synchronization has been achieved and that no other interrupt flags are being set.

## 10.2 DAV-B processing mode / fast PI search mode

This mode is used, for example, when the receiver has been re-tuned to a new station, and a fast search of the PI code, always contained in the A or C' block, is required. The diagram shown in Figure 10, assumes that the RDS decoder is unsynchronized initially and is performing a synchronization search.

During synchronization search the decoder does not set the DAVFLG until a valid A or C' block is detected. If a valid B block is detected immediately, then the decoder is now synchronized and bit SYNC is set to logic 1. In fact, if any 2 good blocks in a valid order are detected, the RDS decoder will synchronize and give an interrupt.

If for some reason a valid B block was not received then the next valid A or C' block is decoded and the DAVFLG set. The BP and BL registers record the A block history.

When the decoder is synchronized, each decoded block will set the DAVFLG (assuming it was reset by a read action) and generate an interrupt.

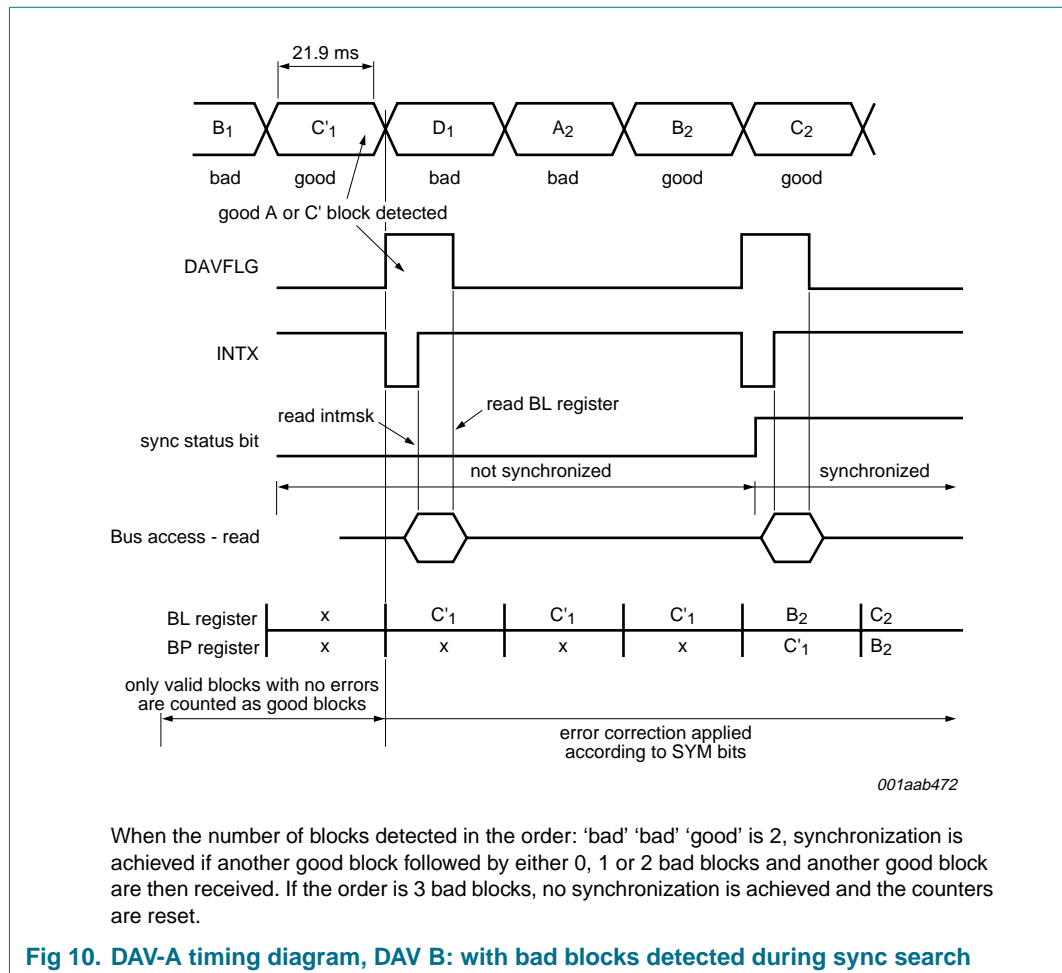

### 10.3 DAV-C reduced processing mode

The DAV-C processing mode is very similar to DAV-A mode with the main exception that a data flag is set only after two new blocks are received. Hence the update rate is reduced by half.

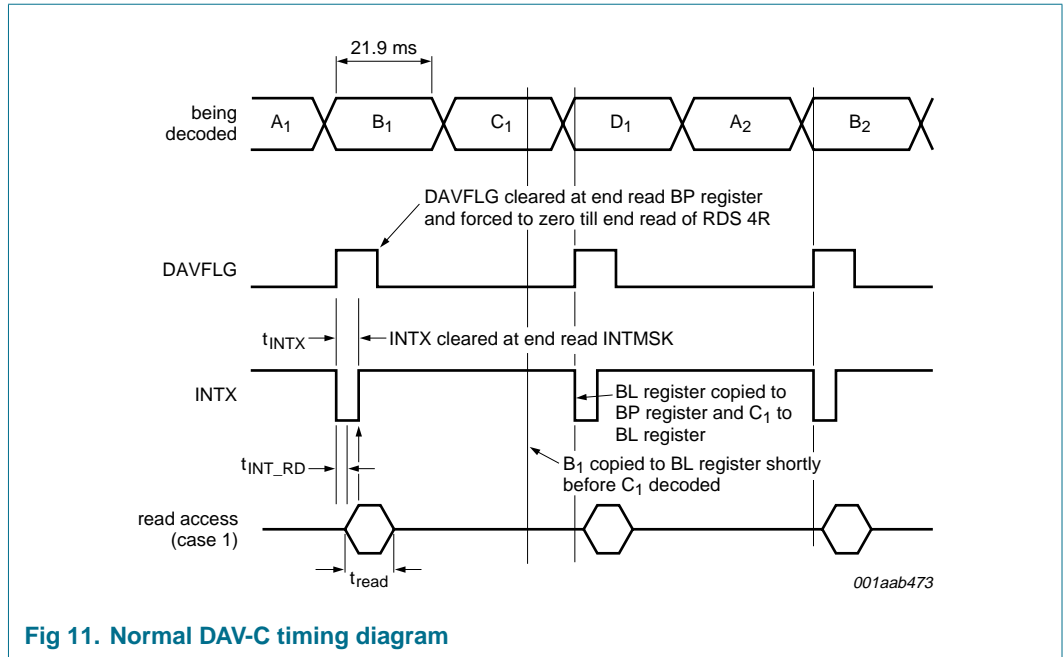

Fig 11. Normal DAV-C timing diagram

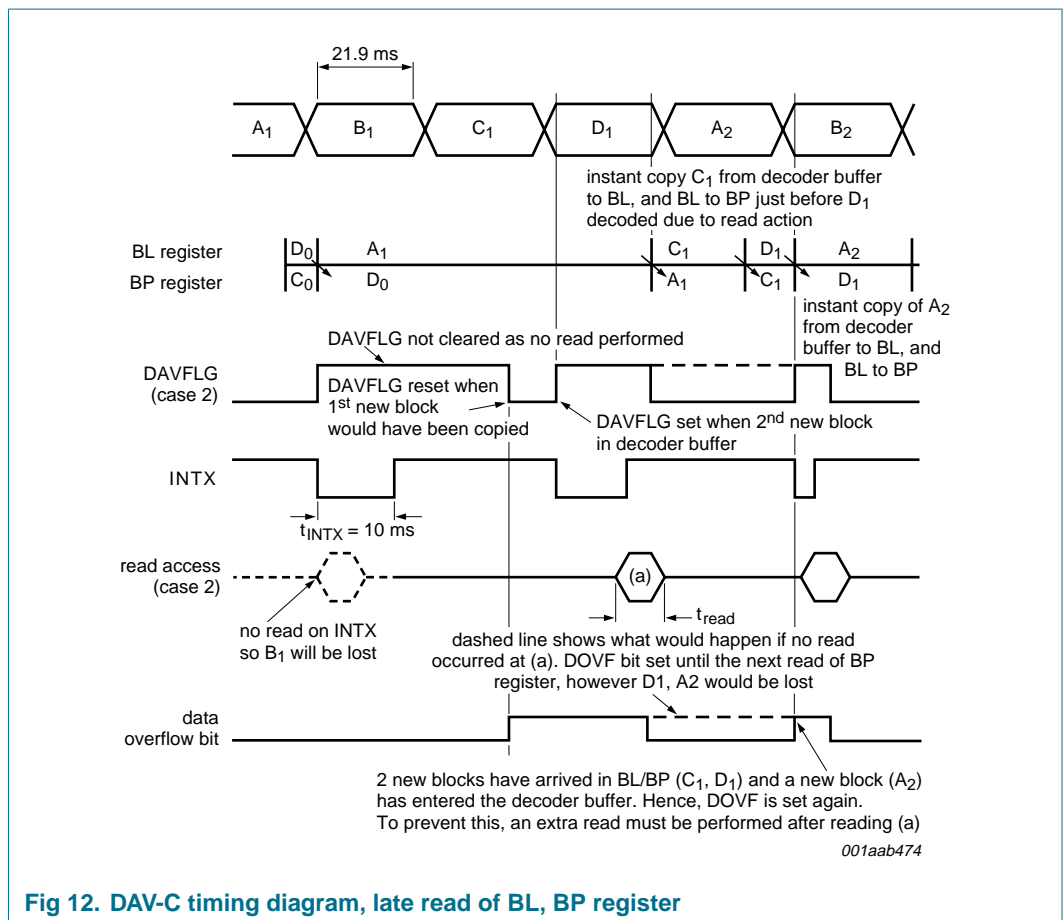

Fig 12. DAV-C timing diagram, late read of BL, BP register

## 10.4 Synchronization

### 10.4.1 Conditions for synchronization

When the RDS decoder is turned on it must be synchronized to extract valid data from the MPX signal. To do so the decoder automatically initiates a search for synchronization. The conditions to meet synchronization and the status of this synchronization can be set and checked by the following bits:

- BBL (Bad Blocks Lose): these bits can be set via the I<sup>2</sup>C-bus and have a value between 0 to 63
- GBL (Good Blocks Lose): these bits can be set via the I<sup>2</sup>C-bus and have a value between 0 to 63
- BBG (Bad Blocks Gain): these bits can be set via the I<sup>2</sup>C-bus and have a value between 0 to 32
- GBC (Good Block Count): these bits can be read via the I<sup>2</sup>C-bus and have a value between 0 to 63
- BBC (Bad Block Count): these bits can be read via the I<sup>2</sup>C-bus and have a value between 0 to 63

When the decoder is not synchronized it will initiate a synchronization search. This involves calculation of the syndrome for each block of 26 received bits on a bit-by-bit basis. When a correct syndrome (and hence block ID) is received the decoder clocks the next 26 bits into the internal registers and performs a second syndrome check. Synchronization is found when a certain number of blocks have been decoded and two good blocks have been found, this number of blocks is defined by the BBG bits. If the first block needed for synchronization has been found and the expected second block (after 26 bits) is an invalid block, then the decoder module internal `bad_blocks_counter` is incremented and the next expected block is calculated; exception: if RBDS mode is selected and the first block is E, then the next expected block is always block A, until synchronization is found or the maximum `bad_blocks_counter` value is reached. If the decoder module internal `bad_blocks_counter` reaches the value of `BBG[4:0]`, then a new synchronization search (bit-by-bit) is started immediately to find a new first block.

The synchronization is monitored by two flywheel counters, GBC and BBC. These are 6-bit counters that can be preset by bits GBL and BBL to values between 0 and 63. Each time a block is decoded and recognized as a bad block the Bad Block Counter value, BBC, is incremented by 1. When the BBC value is equal to the BBL value, synchronization is lost. Bit SYNC will become 0 and bit LSYNCFL is set to indicate the loss of synchronization. The TEA5764HN will now automatically initiate a new synchronization search.

Each time a good block is decoded, the GBC value is incremented. When the GBC value is equal to the GBL value, both counters, BBC and GBC, are set to 0 and a new count starts. The GBC counter is only incremented when the decoder is synchronized.

### 10.4.2 Data overflow

During synchronization, after RDS data is read from the registers, new available blocks are shifted to the registers as described in [Section 10.1](#) to [Section 10.3](#). If the registers are not read in time, the decoder cannot shift any new available block to the registers and hence a data overflow will occur, this is indicated by bit DOVF which is set to 1. Bit DOVF is reset by a read of the registers or if bit NWSY = 1 which results in the start of a new synchronization search.

Each time when a RDS data block is decoded, bit DAVN goes to logic 0 to indicate the presence of a new data block. Bit DAVN also triggers the interrupt output INTX. In principle the microprocessor must now start reading and must have read all RDS data (byte12R to byte19R) before the arrival of a new RDS data block. In the application it is possible that there is too large a delay between the arrival of a new block and reading this block. This can have various causes such as a microprocessor that has to start-up from Sleep mode or when polling is used instead of interrupt based read actions. [Figure 13](#) shows the behavior of bit DAVFLG and bit DAVN when polling, where reading can occur at any time. Note: Bit DAVN sets the INTX oneshot generator when DAVMSK = 1. Unlike INTX, bit DAVN is not cleared by a read of the mask register.

## 10.5 RDS flag behavior during read action

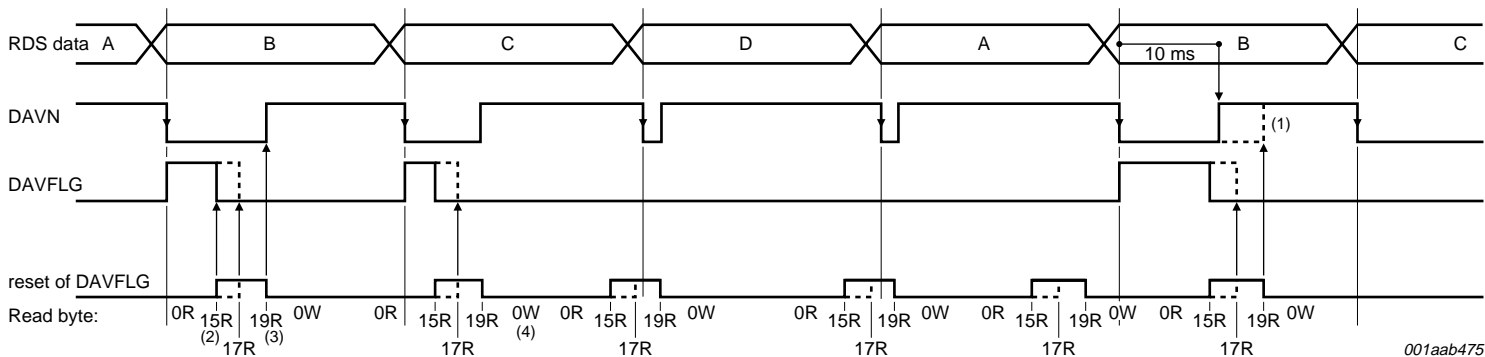

Blocking DAVFLG: at end of reading byte15R or byte17R (DAV-A, B/C) DAVFLG is forced to zero. Only after reading byte19R DAVFLG is released again.

If synchronous reading is performed using ASIC generated interrupts, this problem does not occur.

To prevent undefined situations, byte12R to byte19R should always be read in one action immediately after each other.

Signal DAVN  $\neq$  INTX.

- (1) Normally reading byte19R would reset bit DAVN, but now it is reset after 10 ms, the maximal LOW time of bit DAVN.
- (2) Read of byte15R in DAV-A and DAV-B mode clears DAVFLG. In DAV-C mode two consecutive RDS data blocks are read and hence DAVFLG is reset after reading byte17R instead of byte15R (dotted line).
- (3) Read of byte19R clears bit DAVN.
- (4) Write byte0W (interrupt register).

Fig 13. RDS flag behavior

## 10.6 Error detection and reporting

The TDA5764HN must report information on the number of errors corrected in the last and previously decoded blocks. This is reported in bits ELB and EPB as shown in [Table 29](#).

During synchronization search the error correction is disabled for detection of the first block and is enabled for processing of the second block according to the mode set by the SYM bits as described in [Table 36](#).

## 10.7 RDS test modes

In Test mode the raw RDS clock and RDS data can be recovered directly from pins VAFL and VAFR when bit RDSCDA = 1.

## 10.8 Reading RDS data from the registers

To read RDS data the microprocessor must read byte12R to byte19R. All 8 bytes must be read to reset the status bytes 12R and 13R, i.e. effectively the status bits can be updated by the decoder after reading the last bit of byte19R. Bit DOVF is cleared after reading the last bit of byte19R and the status of bit SYNC does not depend on reading the register, bit SYNC indicates if the decoder is synchronized or not. When starting a read action from byte12R, the decoder blocks updates from the RDS bytes until byte19R has been read. RDS byte12R to byte19R must be read in one read action.

# 11. I<sup>2</sup>C-bus interface

The I<sup>2</sup>C-bus interface is based on “*The I<sup>2</sup>C-bus specification*”, version 2.1 January 2000, expanded by the following definitions.

## 11.1 Write and read mode

**Table 8: I<sup>2</sup>C-bus FM write mode**

S	Byte 1	As	Byte 2	As	Byte n	As	Byte 8	As	P	
START	chip address	R/ $\bar{W}$	ACK	byte0W	ACK	....	ACK	byte6W	ACK	STOP
	0010 000	0		xxxx xxxx				xxxx xxxx		

**Table 9: I<sup>2</sup>C-bus RDS write mode**

S	Byte 1	As	Byte 2	Am	Byte n	As	Byte 8	As	P	
START	chip address	R/ $\bar{W}$	ACK	byte7W	ACK	....	ACK	byte10W	non ACK	STOP
	0010 001	0		xxxx xxxx				xxxx xxxx		

When writing all bytes, byte0W to byte10W can be written with one write action.

**Table 10: I<sup>2</sup>C-bus FM read mode**

S	Byte 1	As	Byte 2	Am	Byte n	Am	Byte 17	NAm	P	
START	chip address	R/ $\bar{W}$	ACK	byte0R	ACK	....	ACK	byte15R	non ACK	STOP
	0010 000	1		xxxx xxxx				xxxx xxxx		

Table 11: I<sup>2</sup>C-bus RDS read mode

S	Byte 1	As	Byte 2	Am	Byte n	Am	Byte 17	NAm	P	
START	chip address	R/W	ACK	byte12R	ACK	.....	ACK	byte27R	non ACK	STOP
	0010 001	1	xxxx xxxx				xxxx xxxx			

Table 12: I<sup>2</sup>C-bus transfer description

Label	Definition
S	START condition
Byte 1	I <sup>2</sup> C-bus chip address (7 bits) R/W = 0 for write action and R/W = 1 for read action
As	acknowledge from slave TEA5764HN (SDA is LOW)
Byte 2, etc.	data byte (8 bits)
P	STOP condition
Am	acknowledge from master microcontroller (SDA is LOW)
NAm	non acknowledge from master microcontroller (SDA is HIGH)
NA	non acknowledge (SDA is HIGH)

When the TEA5764HN is addressed by the FM radio address, the RDS part (byte12R to byte27R) can be read in one read action. A read does not have to stop at byte11R.

Therefore, by effectively only using the RDS part of the address, ignores some bytes which reduces I<sup>2</sup>C-bus access.

## 11.2 Data transfer

Structure of the I<sup>2</sup>C-bus:

- Slave transceiver
- Subaddresses not used
- Maximum LOW-level input voltage:  $V_{IL} = 0.3 \times V_{VREFDIG}$
- Minimum HIGH-level input voltage:  $V_{IH} = 0.7 \times V_{VREFDIG}$

**Remark:** The I<sup>2</sup>C-bus operates at a maximum clock rate of 400 kHz. It is not allowed to connect the TEA5764HN to a I<sup>2</sup>C-bus operating at a higher clock rate.

Data transfer to the IC:

- Bit 7 of each byte is considered the MSB and has to be transferred as the first bit of the byte
- The LSB indicates the write or read action
- The data becomes valid byte-wise at the appropriate falling edge of the SCL clock
- A STOP condition after any byte can shorten transmission times. When writing to the transceiver by using the STOP condition before completion of the whole transfer:
  - The remaining bytes will contain the old information
  - If the transfer of a byte is not completed the new bits will be used, but a new tuning cycle will not be started



To speed up RDS traffic it is possible to read all the RDS data and then only write back byte INTMSK to set the appropriate mask(s) again.

I<sup>2</sup>C-bus activity:

- With bits PUPD the TEA5764HN can be switched in a low current Standby mode. The I<sup>2</sup>C-bus is then still active
- When the I<sup>2</sup>C-bus interface is deactivated, by making pin BUSENABLE LOW and without programmed Standby mode, the TEA5764HN keeps its normal operation, but is isolated from the I<sup>2</sup>C-bus lines
- It is possible to operate the TEA5764HN with BUSENABLE hard wired to pin VREFDIG, and have the bus interface always active.

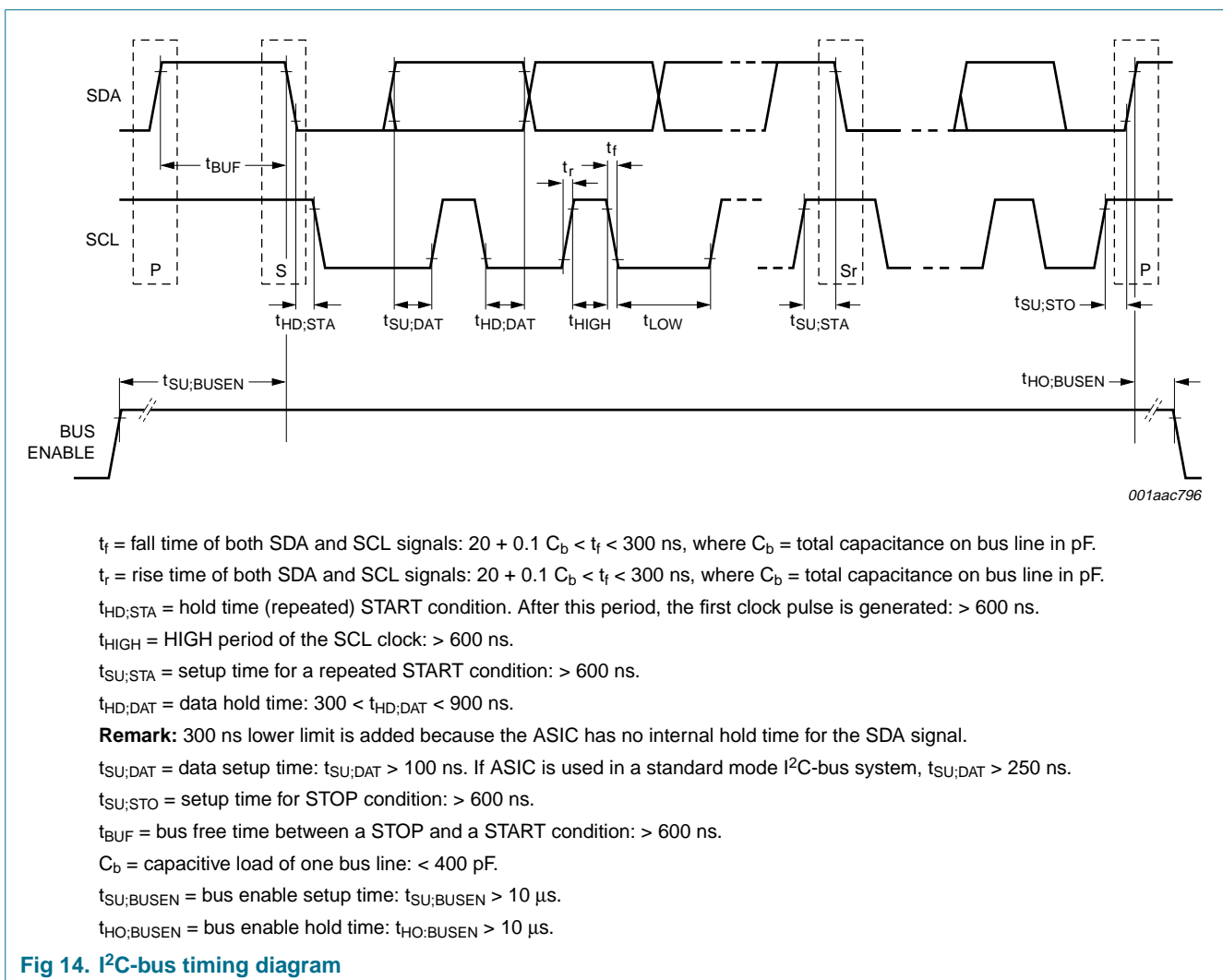

Fig 14. I<sup>2</sup>C-bus timing diagram

## 11.3 Register map

Table 13: Register overview

Byte		Byte name	Access	Reset value	Reference
Read	Write				
0R		INTFLAG	R	00	<a href="#">Table 14</a>
1R	0W	INTMSK	R/W	00	<a href="#">Table 15</a>
2R	1W	FRQSETMSB	R/W	80	<a href="#">Table 16</a>
3R	2W	FRQSETLSB	R/W	00	<a href="#">Table 17</a>
4R	3W	TNCTRL1	R/W	08	<a href="#">Table 18</a>
5R	4W	TNCTRL2	R/W	D2	<a href="#">Table 19</a>
6R		FRQCHKMSB	R	-	<a href="#">Table 20</a>
7R		FRQCHKLSB	R	-	<a href="#">Table 21</a>
8R		IFCHK	R	-	<a href="#">Table 22</a>
9R		LEVCHK	R	-	<a href="#">Table 23</a>
10R	5W	TESTBITS	R/W	00	<a href="#">Table 24</a>
11R	6W	TESTMODE	R/W	00	<a href="#">Table 25</a>
12R		RDSSTAT1	R	-	<a href="#">Table 28</a>
13R		RDSSTAT2	R	-	<a href="#">Table 29</a>
14R		RDSLMSB	R	-	<a href="#">Table 30</a>
15R		RDSLBSB	R	-	<a href="#">Table 31</a>
16R		RDSPMSB	R	-	<a href="#">Table 32</a>
17R		RDSPBSB	R	-	<a href="#">Table 33</a>
18R		RDSBBC	R	-	<a href="#">Table 34</a>
19R		RDSGBC	R	-	<a href="#">Table 35</a>
20R	7W	RDSCTRL1	R/W	00	<a href="#">Table 36</a>
21R	8W	RDSCTRL2	R/W	10	<a href="#">Table 37</a>
22R	9W	PAUSEDET	R/W	00	<a href="#">Table 38</a>
23R	10W	RDSBBL	R/W	00	<a href="#">Table 39</a>
24R		MANID1	R	50	<a href="#">Table 40</a>
25R		MANID2	R	2B	<a href="#">Table 41</a>
26R		CHIPID1	R	57	<a href="#">Table 42</a>
27R		CHIPID2	R	64	<a href="#">Table 43</a>

## 11.4 Byte description

Table 14: INTFLAG - byte0R description

Bit	Symbol	Access	Reset	Functional description
7	DAVFLG	R	0	1 = RDS data is available
6	TESTBIT	R	0	internal use
5	LSYNCFL	R	0	1 = synchronization is lost
4	IFFLAG	R	0	1 = IF count is not correct

**Table 14: INTFLAG - byte0R description ...continued**

Bit	Symbol	Access	Reset	Functional description
3	LEVFLAG	R	0	continuous checking of the RSSI level 1 = RSSI level has dropped below $(V_{SSL[1:0]} - V_{hys})$ during a tuning period (preset or search) 1 = RSSI level has dropped below $V_{SSL[1:0]}$
2	PDFLAG	R	0	1 = pause is detected
1	FRRFLAG	R	0	1 = tuner state machine is ready
0	BLFLAG	R	0	1 = during a search the band limit has been reached or time out

**Table 15: INTMSK - byte1R and byte0W description**

Bit	Symbol	Access	Reset	Functional description
7	DAVMSK	R/W	0	masks bit DAVFLG
6	-	R/W	0	reserved
5	LSYMSK	R/W	0	masks bit LSYNCFL
4	IFMSK	R/W	0	masks bit IFFLAG
3	LEVMSK	R/W	0	masks bit LEVFLAG
2	PDMSK	R/W	0	masks bit PDFLAG
1	FRMSK	R/W	0	masks bit FRRFLAG
0	BLMSK	R/W	0	masks bit BLFLAG

**Table 16: FRQSETMSB - byte2R and byte1W description**

Bit	Symbol	Access	Reset	Functional description
7	SUD	R/W	1	1 = search up 0 = search down
6	SM	R/W	0	1 = Search mode 0 = Preset mode
5	FR13	R/W	0	PLL frequency set bits; see <a href="#">Section 8.5</a>
4	FR12	R/W	0	
3	FR11	R/W	0	
2	FR10	R/W	0	
1	FR09	R/W	0	
0	FR08	R/W	0	

Table 17: FRQSETLSB - byte3R and byte2W description

Bit	Symbol	Access	Reset	Functional description
7	FR07	R/W	0	PLL frequency set bits; see <a href="#">Section 8.5</a>
6	FR06	R/W	0	
5	FR05	R/W	0	
4	FR04	R/W	0	
3	FR03	R/W	0	
2	FR02	R/W	0	
1	FR01	R/W	0	
0	FR00	R/W	0	

Table 18: TNCTRL1 - byte4R and byte3W description

Bit	Symbol	Access	Reset	Functional description
7 and 6	PUPD[1:0]	R/W	00	power-up and power-down 00 = FM off and RDS off 01 = FM on and RDS off 10 = not used 11 = FM on and RDS on
5	BLIM	R/W	0	1 = Japan FM band 76 MHz to 90 MHz 0 = US / Europe FM band 87.5 MHz to 108 MHz
4	SWPM	R/W	0	1 = software port is output of FRRFLAG 0 = SWP
3	IFCTC	R/W	1	1 = IF count time = 15.02 ms 0 = IF count time = 2.02 ms
2	AFM	R/W	0	1 = left and right audio muted 0 = audio not muted
1	SMUTE	R/W	0	1 = soft mute on 0 = soft mute off
0	SNC	R/W	0	1 = stereo noise cancellation on 0 = stereo noise cancellation off

Table 19: TNCTRL2 - byte5R and byte4W description

Bit	Symbol	Access	Reset	Functional description
7	MU	R/W	1	1 = left and right audio hard-muted 0 = no hard mute
6 and 5	SS[1:0]	R/W	10	search stop level 00 = ADC3 01 = ADC5 10 = ADC7 11 = ADC10
4	HLSI	R/W	1	1 = high-side injection 0 = low-side injection

Table 19: TNCTRL2 - byte5R and byte4W description ...continued

Bit	Symbol	Access	Reset	Functional description
3	MST	R/W	0	1 = forced mono 0 = stereo on
2	SWP	R/W	0	1 = pin SWPORT is HIGH 0 = pin SWPORT is LOW
1	DTC	R/W	1	1 = de-emphasis time constant = 50 $\mu$ s 0 = de-emphasis time constant = 75 $\mu$ s
0	AHLSI	R/W	0	see <a href="#">Section 8.21.3</a> for the functionality of this bit

Table 20: FRQCHKMSB - byte6R description

Bit	Symbol	Access	Reset	Functional description
7	-	-	-	reserved
6	-	-	-	reserved
5	PLL13	R	-	output frequency MSB
4	PLL12	R	-	output frequency
3	PLL11	R	-	output frequency
2	PLL10	R	-	output frequency
1	PLL09	R	-	output frequency
0	PLL08	R	-	output frequency

Table 21: FRQCHKLSB - byte7R description

Bit	Symbol	Access	Reset	Functional description
7	PLL07	R	-	output frequency
6	PLL06	R	-	output frequency
5	PLL05	R	-	output frequency
4	PLL04	R	-	output frequency
3	PLL03	R	-	output frequency
2	PLL02	R	-	output frequency
1	PLL01	R	-	output frequency
0	PLL00	R	-	output frequency LSB

Table 22: IFCHK - byteR8 description

Bit	Symbol	Access	Reset	Functional description
7	IF6	R	-	IF count MSB
6	IF5	R	-	IF count
5	IF4	R	-	IF count
4	IF3	R	-	IF count
3	IF2	R	-	IF count
2	IF1	R	-	IF count
1	IF0	R	-	IF count LSB
0	-	-	-	reserved

**Table 23: LEVCHK - byte9R description**

Bit	Symbol	Access	Reset	Functional description
7	LEV3	R	-	level count MSB
6	LEV2	R	-	level count bit
5	LEV1	R	-	level count bit
4	LEV0	R	-	level count LSB
3	LD	R	-	1 = PLL is locked 0 = PLL is not locked
2	STEREO	R	-	1 = pilot detected [1] 0 = no pilot detected
1	-	-	-	reserved
0	-	-	-	reserved

[1] This bit does not switch the radio to mono or stereo, this depends on the RF input level as shown in sections 'Mono stereo blend' or 'mono stereo switched' in [Table 47](#).

**Table 24: TESTBITS - byte10R and byte5W description**

Bit	Symbol	Access	Reset	Functional description
7	LHM	R/W	0	1 = left audio output is hard muted 0 = left audio output is not hard muted
6	RHM	R/W	0	1 = right audio output is hard muted 0 = right audio output is not hard muted
5	RDSCDA	R/W	0	1 = pin VAFL is RDS clock and pin VAFR is RDS data 0 = normal operation
4	LHSW	R/W	0	1 = level hysteresis is large 0 = level hysteresis is small
3	TRIGFR	R/W	0	1 = reference frequency selected pin FREQIN 0 = crystal as reference pin XTAL
2	LDX	R/W	0	1 = local DX on, -6 dB gain of LNA 0 = local DX off, LNA has normal gain
1	RFAGC	R/W	0	1 = RFAGC off 0 = RFAGC on
0	INTCTRL	R/W	0	when this bit is set to logic 1 an interrupt is generated on pin INTX

**Table 25: TESTMODE - byte11R and byte6W description**

Bit	Symbol	Access	Reset	Functional description
7 to 5	-	R/W	0	reserved
4	TM	R/W	0	1 = oscillator output and programmable divider output are enabled 0 = normal operation

Table 25: TESTMODE - byte11R and byte6W description ...continued

Bit	Symbol	Access	Reset	Functional description
3	TB3	R/W	0	test bits: <a href="#">Table 27</a> describes selection of signals output to the SWPORT when SWPM = 0; when TM = 1; TB_[3:0] = 0; which effectively is an AND function.
2	TB2	R/W	0	
1	TB1	R/W	0	
0	TB0	R/W	0	

Table 26: LH - RSSI level hysteresis

RSSI ADC search stop level	RSSI hysteresis threshold	
	LHSW = 0	LHSW = 1
3	0	0
5	2	1
7	4	3
10	7	5

Table 27: Test bits (SWPM = 0)

TB3	TB2	TB1	TB0	SWPORT output signal
0	0	0	0	bit SWP of byte4W, depending on bits SWPM and SWP
0	0	0	1	oscillator output 32.768 kHz; when TM = 1
0	0	1	0	lock detect bit LD
0	0	1	1	stereo bit STEREO
0	1	0	0	programmable divider; when TM = 1
0	1	0	1	PSCOn; see <a href="#">Section 9.1.4.6</a>
0	1	1	0	57 kHz clock
0	1	1	1	3-state
1	0	0	0	output of RDS comparator
1	0	0	1	reserved
1	0	1	0	reserved
1	0	1	1	reserved
1	1	0	0	reserved

Table 28: RDSSTAT1 - byte12R description

Bit	Symbol	Access	Reset	Functional description
7	-	-	-	reserved
6 to 4	BLID[2:0]	R	-	block ID of last block 000 = A 001 = B 010 = C 011 = D 100 = C' 101 = E 110 = invalid block E (RBDS) 111 = invalid block

**Table 28: RDSSTAT1 - byte12R description ...continued**

Bit	Symbol	Access	Reset	Functional description
3	-	-	-	-
2	-	-	-	-
1 and 0	ELB[1:0]	R	-	number of errors for last processed block 00 = no errors 01 = maximum 2 bits 10 = maximum 5 bits 11 = uncorrectable

**Table 29: RDSTAT2 - byte13R description**

Bit	Symbol	Access	Reset	Functional description
7 to 5	BPID[2:0]	R	-	block ID of previous block 000 = A 001 = B 010 = C 011 = D 100 = C' 101 = E 110 = invalid block E (RBDS) 111 = invalid block
4 and 3	EPB[1:0]	R	-	number of errors for previous processed block 00 = no errors 01 = maximum 2 bits 10 = maximum 5 bits 11 = uncorrectable
2	SYNC	R	-	1 = RDS bitstream is synchronized 0 = not synchronized
1	RSTD	R	-	1 = power-on reset detected 0 = no power-on reset detected
0	DOVF	R	-	1 = data overflow occurred during read operation 0 = normal operation

**Table 30: RDSRLBMSB - byte14R description**

Bit	Symbol	Access	Reset	Functional description
7	BL15	R	-	last RDS data byte - MSB
6	BL14	R	-	last RDS data byte
5	BL13	R	-	last RDS data byte
4	BL12	R	-	last RDS data byte
3	BL11	R	-	last RDS data byte



Table 30: RDSRLBMSB - byte14R description ...continued

Bit	Symbol	Access	Reset	Functional description
2	BL10	R	-	last RDS data byte
1	BL9	R	-	last RDS data byte
0	BL8	R	-	last RDS data byte

Table 31: RDSLBLESB - byte15R description

Bit	Symbol	Access	Reset	Functional description
7	BL7	R	-	last RDS data byte
6	BL6	R	-	last RDS data byte
5	BL5	R	-	last RDS data byte
4	BL4	R	-	last RDS data byte
3	BL3	R	-	last RDS data byte
2	BL2	R	-	last RDS data byte
1	BL1	R	-	last RDS data byte
0	BL0	R	-	last RDS data byte - LSB

Table 32: RDSPBMSB - byte16R description

Bit	Symbol	Access	Reset	Functional description
7	BP15	R	-	previous RDS data byte - MSB
6	BP14	R	-	previous RDS data byte
5	BP13	R	-	previous RDS data byte
4	BP12	R	-	previous RDS data byte
3	BP11	R	-	previous RDS data byte
2	BP10	R	-	previous RDS data byte
1	BP9	R	-	previous RDS data byte
0	BP8	R	-	previous RDS data byte

Table 33: RDSPBLESB - byte17R description

Bit	Symbol	Access	Reset	Functional description
7	BP7	R	-	previous RDS data byte
6	BP6	R	-	previous RDS data byte
5	BP5	R	-	previous RDS data byte
4	BP4	R	-	previous RDS data byte
3	BP3	R	-	previous RDS data byte
2	BP2	R	-	previous RDS data byte
1	BP1	R	-	previous RDS data byte
0	BP0	R	-	previous RDS data byte - LSB

**Table 34: RDSBBC - byte18R description**

Bit	Symbol	Access	Reset	Functional description
7	BBC5	R	-	bad block count MSB
6	BBC4	R	-	bad block count
5	BBC3	R	-	bad block count
4	BBC2	R	-	bad block count
3	BBC1	R	-	bad block count
2	BBC0	R	-	bad block count LSB
1	GBC5	R	-	good block count MSB
0	GBC4	R	-	good block count

**Table 35: RDSGBC - byte19R description**

Bit	Symbol	Access	Reset	Functional description
7	GBC3	R	-	good block count
6	GBC2	R	-	good block count
5	GBC1	R	-	good block count
4	GBC0	R	-	good block count LSB
3 to 0	-	-	-	reserved

**Table 36: RDSCTRL1 - byte20R and byte7W description**

Bit	Symbol	Access	Reset	Functional description
7	NWSY	R/W	0	1 = start new synchronization 0 = normal processing
6 and 5	SYM[1:0]	R/W	00	error correction 00 = no correction 01 = maximum 2 bits 10 = maximum 5 bits 11 = no correction
4	RBDS	R/W	0	1 = RBDS processing mode 0 = RDS processing mode
3 and 2	DAC[1:0]	R/W	00	RDS data output mode 00 = DAVA 01 = DAVB 10 = DAVC 11 = not used
1 and 0	-	-	-	reserved

**Table 37: RDSCTRL2 - byte21R and byte8W description**

Bit	Symbol	Access	Reset	Functional description
7 to 5	-	-	-	reserved
4	BBG4	R/W	1	bad blocks gain MSB
3	BBG3	R/W	0	bad blocks gain

Table 37: RDSCTRL2 - byte21R and byte8W description ...continued

Bit	Symbol	Access	Reset	Functional description
2	BBG2	R/W	0	bad blocks gain
1	BBG1	R/W	0	bad blocks gain
0	BBG0	R/W	0	bad blocks gain LSB

Table 38: PAUSEDET - byte22R and byte9W description

Bit	Symbol	Access	Reset	Functional description
7 and 6	PT[1:0]	R/W	00	pause time 00 = 20 ms 01 = 40 ms 10 = 80 ms 11 = 160 ms
5 and 4	PL[1:0]	R/W	00	pause level L = R 00 = 1 kHz 01 = 1.6 kHz 10 = 2.5 kHz 11 = 4.0 kHz
3	GBL5	R/W	0	number of good blocks lose MSB
2	GBL4	R/W	0	number of good blocks lose
1	GBL3	R/W	0	number of good blocks lose
0	GBL2	R/W	0	number of good blocks lose

Table 39: RDSBBL - byte23R and byte10W description

Bit	Symbol	Access	Reset	Functional description
7	GBL1	R/W	0	number of good blocks lose
6	GBL0	R/W	0	number of good blocks lose LSB
5	BBL5	R/W	0	number of bad blocks lose MSB
4	BBL4	R/W	0	number of bad blocks lose
3	BBL3	R/W	0	number of bad blocks lose
2	BBL2	R/W	0	number of bad blocks lose
1	BBL1	R/W	0	number of bad blocks lose
0	BBL0	R/W	0	number of bad blocks lose LSB

Table 40: MANID1 - byte24R description

Bit	Symbol	Access	Reset	Functional description
7	VERSION3	R	0	version code MSB
6	VERSION2	R	1	version code
5	VERSION1	R	0	version code
4	VERSION0	R	1	version code LSB
3	MANID10	R	0	manufacturer ID code MSB

Table 40: MANID1 - byte24R description ...continued

Bit	Symbol	Access	Reset	Functional description
2	MANID9	R	0	manufacturer ID code
1	MANID8	R	0	manufacturer ID code
0	MANID7	R	0	manufacturer ID code

Table 41: MANID2 - byte25R description

Bit	Symbol	Access	Reset	Functional description
7	MANID6	R	0	manufacturer ID code
6	MANID5	R	0	manufacturer ID code
5	MANID4	R	1	manufacturer ID code
4	MANID3	R	0	manufacturer ID code
3	MANID2	R	1	manufacturer ID code
2	MANID1	R	0	manufacturer ID code
1	MANID0	R	1	manufacturer ID code LSB
0	IDAV	R	1	1 = manufacturer ID available 0 = no manufacturer ID available

Table 42: CHIPID1 - byte26R description

Bit	Symbol	Access	Reset	Functional description
7	CHIP ID15	R	0	chip identification code MSB
6	CHIP ID14	R	1	chip identification code
5	CHIP ID13	R	0	chip identification code
4	CHIP ID12	R	1	chip identification code
3	CHIP ID11	R	0	chip identification code
2	CHIP ID10	R	1	chip identification code
1	CHIP ID9	R	1	chip identification code
0	CHIP ID8	R	1	chip identification code

Table 43: CHIPID2 - byte27R description

Bit	Symbol	Access	Reset	Functional description
7	CHIP ID7	R	0	chip identification code
6	CHIP ID6	R	1	chip identification code
5	CHIP ID5	R	1	chip identification code
4	CHIP ID4	R	0	chip identification code
3	CHIP ID3	R	0	chip identification code
2	CHIP ID2	R	1	chip identification code
1	CHIP ID1	R	0	chip identification code
0	CHIP ID0	R	0	chip identification code LSB

## 12. Limiting values

**Table 44: Limiting values**

In accordance with the Absolute Maximum Rating System (IEC 60134).

Symbol	Parameter	Conditions	Min	Max	Unit	
V <sub>LO1</sub>	VCO tuned circuit output 1		-0.3	+8	V	
V <sub>LO2</sub>	VCO tuned circuit output 2		-0.3	+8	V	
V <sub>CCD</sub>	digital supply voltage		-0.3	+5.5	V	
V <sub>CCA</sub>	analog supply voltage		-0.3	+8	V	
V <sub>I/O(n)</sub>	voltage on all inputs and outputs	with respect to ground	-0.3	+5.5	V	
T <sub>stg</sub>	storage temperature		-55	+150	°C	
T <sub>amb</sub>	ambient temperature		-40	+85	°C	
V <sub>esd</sub>	electrostatic discharge voltage	MM	[1]	-200	+200	V
		HBM				
		all pins except PILLP, RFIN1, RFIN2	[2]	-2000	+2000	V
		pin PILLP only	[2]	-1000	+2000	V
		pins RFIN1 and RFIN2	[2]	-1500	+2000	V
		CDM	[3]	-500	+500	V

[1] Machine model I (L = 0.75 mH, R = 10 Ω, C = 200 pF).

[2] Human body model (R = 1.5 kΩ, C = 100 pF).

[3] Charged device model (JEDEC standard JESD22-C101C).

## 13. Thermal characteristics

**Table 45: Thermal characteristics**

Symbol	Parameter	Conditions	Typ	Unit
R <sub>th(j-a)</sub>	thermal resistance from junction to ambient	in free air	80	K/W

## 14. Static characteristics

**Table 46: Characteristics**

The minimum and maximum values include spread due to  $V_{CCA} = V_{CCD} = 2.5\text{ V to }3.3\text{ V}$  and  $T_{amb} = -20\text{ }^{\circ}\text{C to }+85\text{ }^{\circ}\text{C}$ ; unless otherwise specified.

Symbol	Parameter	Conditions	Min	Typ	Max	Unit
<b>Supply voltages</b>						
$V_{CCA}$	analog supply voltage		2.5	2.7	3.3	V
$V_{CCD}$	digital supply voltage		2.5	2.7	3.3	V
$V_{VREFDIG}$	digital reference voltage for I <sup>2</sup> C-bus interface on pin VREFDIG		1.65	1.8	$V_{CCD}$	V
<b>Supply currents</b>						
$I_{CCA}$	analog supply current	$V_{CCA} = 2.5\text{ V to }3.3\text{ V}$				
		operating mode	12	13.7	16	mA
		Standby mode	0	0.1	1	$\mu\text{A}$
$I_{CCD}$	digital supply current	$V_{CCD} = 2.5\text{ V to }3.3\text{ V}$				
		operating mode	0.3	0.7	1.5	mA
		Standby mode	1	15	22.5	$\mu\text{A}$
$I_{VREFDIG}$	digital reference supply current	operating mode; $V_{VREFDIG} = 1.65\text{ V to }V_{CCD}$	0	0.5	1	$\mu\text{A}$
<b>DC operating points</b>						
$V_{LOOPSW}$	voltage on pin LOOPSW		$V_{CD3} - 0.2$	-	$V_{CD3}$	V
$V_{CPOUT}$	voltage on pin CPOUT		0.1	-	$V_{CD3} - 0.1$	V
$V_{LO1}$	voltage on pin LO1		$V_{CD3} - 0.1$	-	$V_{CD3}$	V
$V_{LO2}$	voltage on pin LO2		$V_{CD3} - 0.1$	-	$V_{CD3}$	V
$V_{PILLP}$	voltage on pin PILLP		1.09	1.37	1.65	V
$V_{TMUTE}$	voltage on pin TMUTE	$V_{RF} = 0\text{ V}$ , measured with respect to pin CD3	0.6	0.7	0.8	mV
$V_{VAFL}$	voltage on pin VAFL	$f_{RF} = 98\text{ MHz}$ ; $V_{RF} = 1\text{ mV}$ ; no modulation	800	850	940	mV
$V_{VAFR}$	voltage on pin VAFR	$f_{RF} = 98\text{ MHz}$ ; $V_{RF} = 1\text{ mV}$ ; no modulation	800	850	940	mV
$V_{MPXOUT}$	voltage on pin MPXOUT	$f_{RF} = 98\text{ MHz}$ ; $V_{RF} = 1\text{ mV}$ ; no modulation	830	900	950	mV
$V_{MPXIN}$	voltage on pin MPXIN	$f_{RF} = 98\text{ MHz}$ ; $V_{RF} = 1\text{ mV}$ ; no modulation	0.2	0.4	0.5	V
$V_{FREQIN}$	voltage on pin FREQIN	TRIGFR = 1	1.3	1.5	1.7	V
		TRIGFR = 0	0	0.05	0.1	V
$V_{XTAL}$	voltage on pin XTAL to CD3	TRIGFR = 1	0.9	1.17	1.3	V
		TRIGFR = 0	0.8	1	1.2	V
$V_{RFIN1}$	voltage on pin RFIN1		420	530	680	mV
$V_{RFIN2}$	voltage on pin RFIN2		420	530	680	mV
$V_{CAGC}$	voltage on pin CAGC	$V_{RF} = 0\text{ V}$	1	1.57	2	V

## 15. Dynamic characteristics

**Table 47: Characteristics**

See [Figure 1](#); all AC values are given in RMS; the minimum and maximum values include spread due to  $V_{CCA} = V_{CCD} = 2.5$  V to 3.3 V and  $T_{amb} = -20$  °C to +85 °C; unless otherwise specified. All RF input values are defined in potential difference, except when EMF is explicitly stated.

Symbol	Parameter	Conditions	Min	Typ	Max	Unit
<b>Voltage controlled oscillator</b>						
$f_{osc}$	oscillator frequency		150	-	217	MHz
<b>Reference frequency input; pin FREQIN</b>						
$R_i$	input resistance		500	-	-	k $\Omega$
$C_i$	input capacitance		5	6	7	pF
$f_{rsn}$	resonance frequency		-	32.768	-	kHz
$\Delta f_{rsn}$	resonance frequency deviation	$T_{amb} = 25$ °C	-20	-	+20	ppm
		$T_{amb} = -20$ °C to +85 °C	-150	-	+150	ppm
$\delta$	duty cycle	square wave	30	-	70	%
$V_{IH}$	HIGH-level input voltage	square wave	1.15	-	$V_{CC}$	V
$V_{IL}$	LOW-level input voltage	square wave	0	-	0.55	V
C/N	carrier-to-noise ratio	at 10 kHz	-151	-	-	dBc/Hz
<b>Crystal oscillator 32.768 kHz; pin XTAL</b>						
$f_{rsn}$	resonance frequency	$T_{amb} = 25$ °C	-	32.768	-	kHz
$\Delta f_{rsn}$	resonance frequency deviation		-20	-	+20	ppm
$C_{shunt}$	shunt capacitance		-	-	3.5	pF
$C_m$	motional capacitance		1.5	-	3.0	fF
$R_s$	series resistance		-	-	75	k $\Omega$
<b>Synthesizer</b>						
<b>Programmable divider</b>						
$D/D_{prog}$	programmable divider ratio	FRQSETMSB[15:8] = XX11 1111; FRQSETLSB[7:0] = 1111 1110	-	-	8191	
		FRQSETMSB[15:8] = XX00 1000; FRQSETLSB[7:0] = 0000 0000	2048	-	-	
$D_{step(prog)}$	programmable divider step size		-	1	-	
<b>Charge pump; pin CPOUT; <math>V_{LOOPS\ SW} = 0.2</math> V to <math>(V_{LO2} - 0.2)</math> V; <math>f_{VCO} &gt; f_{ref} \times</math> divider ratio</b>						
$I_{M(sink)}$	peak sink current		250	500	1000	nA
$I_{M(source)}$	peak source current		250	500	1000	nA
<b>IF counter</b>						
N	length		-	7	-	bit
$V_{sens}$	sensitivity voltage		-	5.5	15	$\mu$ V
$n_{count}$	count result for search stop	$10 \mu\text{V} < V_{RF} < 1$ V	31	-	3C	Hex
T	period	IFCTC = 1	-	15625	-	$\mu$ s
		IFCTC = 0	-	1953	-	$\mu$ s
$f_{res}$	frequency resolution		-	4096	-	Hz

**Table 47: Characteristics ...continued**

See Figure 1; all AC values are given in RMS; the minimum and maximum values include spread due to  $V_{CCA} = V_{CCD} = 2.5\text{ V}$  to  $3.3\text{ V}$  and  $T_{amb} = -20\text{ }^{\circ}\text{C}$  to  $+85\text{ }^{\circ}\text{C}$ ; unless otherwise specified. All RF input values are defined in potential difference, except when EMF is explicitly stated.

Symbol	Parameter	Conditions	Min	Typ	Max	Unit
<b>Logic pins; pins BUSENABLE, SCL and SDA</b>						
$R_i$	input resistance		10	-	-	$M\Omega$
$V_{IH}$	HIGH-level input voltage	input switching level up	$0.7V_{VREFDIG}$	-	$V_{VREFDIG} + 0.3$	V
$V_{IL}$	LOW-level input voltage	input switching level down	-0.3	-	$0.3V_{VREFDIG}$	V
<b>Software programmable port; pin SWPORT</b>						
$V_{O(max)}$	maximum output voltage	$I_{load} = 150\ \mu\text{A}$	$V_{VREFDIG} - 0.2$	-	$V_{VREFDIG}$	V
$V_{O(min)}$	minimum output voltage	$I_{load} = 150\ \mu\text{A}$	0	-	0.2	V
$I_{sink(max)}$	maximum sink current		400	-	2000	$\mu\text{A}$
$I_{source(max)}$	maximum source current		500	-	1100	$\mu\text{A}$
$I_{L(max)}$	maximum leakage current	$V_{SWPORT} = 0\text{ V to }5\text{ V}$	-1.0	-	+1.0	$\mu\text{A}$
<b>Interrupt flag; pin INTX; <math>V_{VREFDIG} = 1.65\text{ V to }1.95\text{ V}</math>; <math>I_{load(max)} = 200\ \mu\text{A}</math> or <math>R_{pu}</math> of second device connected to pin INTX is <math>18\text{ k}\Omega \pm 20\%</math></b>						
$V_{O(max)}$	maximum output voltage		$V_{VREFDIG} - 0.2$	-	$V_{VREFDIG}$	V
$V_{O(min)}$	minimum output voltage		0.130	0.215	0.4	V
$I_{pd}$	pull-down current		500	680	1200	$\mu\text{A}$
$R_{pu}$	pull-up resistance		14.4	18	22.5	$\text{k}\Omega$
$t_L$	LOW time	one-shot pulse time	9.9	9.98	10	ms

**Table 48: FM signal channel characteristics**

See Figure 1; all AC values are given in RMS; the min. and max. values include spread due to  $V_{CCA} = V_{CCD} = 2.5\text{ V}$  to  $3.3\text{ V}$  and  $T_{amb} = -20\text{ }^{\circ}\text{C}$  to  $+85\text{ }^{\circ}\text{C}$ ; unless otherwise specified. All RF input values are defined in potential difference, except when EMF is explicitly stated.

Symbol	Parameter	Conditions	Min	Typ	Max	Unit
<b>FM RF input; pins RFIN1 and RFIN2</b>						
$R_i$	input resistance	connected to pin GNDRF	75	100	125	$\Omega$
$C_i$	input capacitance	connected to pin GNDRF	2.5	4	6	pF
$V_{sens(EMF)}$	sensitivity EMF value voltage	$f_{RF} = 76\text{ MHz to }108\text{ MHz}$ ; $\Delta f = 22.5\text{ kHz}$ ; $f_{mod} = 1\text{ kHz}$ ; (S+N)/N = 26 dB; $TC_{deem} = 75\ \mu\text{s}$ ; A-weighting filter; $B_{aud} = 300\text{ Hz to }15\text{ kHz}$	-	2.3	3.5	$\mu\text{V}$
$IP3_{in}$	in-band 3rd-order intercept point	$\Delta f_1 = 200\text{ kHz}$ ; $\Delta f_2 = 400\text{ kHz}$ ; $f_{tune} = 76\text{ MHz to }108\text{ MHz}$ ; RF <sub>agc</sub> = off	78	87	-	$\text{dB}\mu\text{V}$
$IP3_{out}$	out-of-band 3rd-order intercept point	$\Delta f_1 = 4\text{ MHz}$ ; $\Delta f_2 = 8\text{ MHz}$ ; $f_{tune} = 76\text{ MHz to }108\text{ MHz}$ ; RF <sub>agc</sub> = off	87	93	-	$\text{dB}\mu\text{V}$
<b>In-band AGC</b>						
$V_{i(AGC)(min)}$	minimum RF AGC input voltage	$f_{RF} = 98\text{ MHz}$ ; $\Delta V_{th(mute)} / \Delta V_{sens(EMF)} < 4\text{ mV/dB}\mu\text{V}$	55	61	67	$\text{dB}\mu\text{V}$



**Table 48: FM signal channel characteristics ...continued**

See [Figure 1](#); all AC values are given in RMS; the min. and max. values include spread due to  $V_{CCA} = V_{CCD} = 2.5\text{ V}$  to  $3.3\text{ V}$  and  $T_{amb} = -20\text{ }^{\circ}\text{C}$  to  $+85\text{ }^{\circ}\text{C}$ ; unless otherwise specified. All RF input values are defined in potential difference, except when EMF is explicitly stated.

Symbol	Parameter	Conditions	Min	Typ	Max	Unit
<b>Wideband AGC</b>						
$V_{i(RF)}$	RF input voltage	$f_{RF} = 93\text{ MHz}$ ; $f_{RF2} = 98\text{ MHz}$ ; $V_{RF2} = 50\text{ dB}\mu\text{V}$ ; $\Delta V_{th(mute)} /$ $\Delta V_{sens(EMF)} < 4\text{ mV/dB}\mu\text{V}$ ; radio tuned to 98 MHz	66	72	78	dB $\mu\text{V}$
<b>IF filter</b>						
$f_{center}$	center frequency		215	225	235	kHz
B	bandwidth		85	94	102	kHz
S	selectivity	$f_{tune} = 76\text{ MHz}$ to $108\text{ MHz}$ high-side; $\Delta f = +200\text{ kHz}$ low-side; $\Delta f = -200\text{ kHz}$ high-side; $\Delta f = +100\text{ kHz}$ low-side; $\Delta f = -100\text{ kHz}$	[1] 39 32 8 8	43 36 12 12	- - - -	dB dB dB dB
IR	image rejection	$f_{tune} = 76\text{ MHz}$ to $108\text{ MHz}$ ; $V_{RF} = 50\text{ dB}\mu\text{V}$	24	30	-	dB
<b>FM IF level detector and mute voltage</b>						
$V_{IF}$	IF voltage	$V_{RF} = 0\text{ }\mu\text{V}$ $V_{RF} = 3\text{ }\mu\text{V}$	1.5 1.6	1.55 1.61	1.6 1.7	V V
$V_{IF(slope)}$	slope of IF voltage level	$\Delta V_{level} / \Delta V_{RF}$ ; $V_{RF} = 10\text{ }\mu\text{V}$ to $500\text{ }\mu\text{V}$	130	170	210	mV/20dB
$V_{ADC(start)}$	ADC start voltage		2	3	5	$\mu\text{V}$
$G_{step}$	step resolution gain		2	3	5	dB
$R_{TMUTE}$	pin TMUTE output resistance		280	400	520	k $\Omega$
<b>FM demodulator</b>						
$V_o$	output voltage	$V_{RF} = 1\text{ mV}$ ; $L = R$ ; $\Delta f = 22.5\text{ kHz}$ ; $f_{mod} = 1\text{ kHz}$ ; $DTC = 0$ ; $B_{aud} = 300\text{ Hz}$ to $15\text{ kHz}$	55	70	75	mV
$R_o$	output resistance		-	-	500	$\Omega$
$I_{sink}$	sink current		30	-	-	$\mu\text{A}$
(S+N)/N	maximum signal-to-noise ratio	$f_{RF} = 76\text{ MHz}$ to $108\text{ MHz}$ ; $V_{RF} = 1\text{ mV}$ ; $L = R$ ; $\Delta f = 22.5\text{ kHz}$ ; $f_{mod} = 1\text{ kHz}$ ; $TC_{deem} = 75\text{ }\mu\text{s}$ ; A-weighting filter; $B_{aud} = 300\text{ Hz}$ to $15\text{ kHz}$	54	57	-	dB
THD	total harmonic distortion	$V_{RF} = 1\text{ mV}$ ; $L = R$ ; $\Delta f = 75\text{ kHz}$ ; $f_{mod} = 1\text{ kHz}$ ; $DTC = 0$ ; A-weighting filter; $B_{aud} = 300\text{ Hz}$ to $15\text{ kHz}$ ; see <a href="#">Figure 17</a>	-	0.4	0.9	%
THD <sub>OD</sub>	total harmonic distortion overdrive	$V_{RF} = 1\text{ mV}$ ; $L = R$ ; $\Delta f = 100\text{ kHz}$ ; $f_{mod} = 1\text{ kHz}$ ; $DTC = 0$ ; A-weighting filter; $B_{aud} = 300\text{ Hz}$ to $15\text{ kHz}$ ; see <a href="#">Figure 17</a>	-	-	1	%

**Table 48: FM signal channel characteristics ...continued**

See [Figure 1](#); all AC values are given in RMS; the min. and max. values include spread due to  $V_{CCA} = V_{CCD} = 2.5 \text{ V}$  to  $3.3 \text{ V}$  and  $T_{amb} = -20^\circ\text{C}$  to  $+85^\circ\text{C}$ ; unless otherwise specified. All RF input values are defined in potential difference, except when EMF is explicitly stated.

Symbol	Parameter	Conditions	Min	Typ	Max	Unit
$AM_{sup}$	AM suppression	L = R; $\Delta f = 22.5 \text{ kHz}$ ; $f_{mod} = 1 \text{ kHz}$ ; $V_{RF} = 100 \mu\text{V}$ to $10 \text{ mV}$ ; $m = 0.3$ ; DTC = 0; $B_{aud} = 300 \text{ Hz}$ to $15 \text{ kHz}$	-40	-	-	dB
<b>Soft mute; SMUTE = 1; <math>\Delta f = 22.5 \text{ kHz}</math>; <math>f_{mod} = 1 \text{ kHz}</math></b>						
$V_{start(mute)}$	mute start voltage	relative to $V_{VAFL}$ at $V_{RF} = 1 \text{ mV}$ ; $\alpha_{mute} = 3 \text{ dB}$	3	5	10	$\mu\text{V}$
$\alpha_{mute}$	mute attenuation	$V_{RF} = 1 \mu\text{V}$ ; L = R; DTC = 0; $B_{aud} = 300 \text{ Hz}$ to $15 \text{ kHz}$	10	20	30	dB
<b>MPX decoder</b>						
$V_{VAFL}$	left audio output voltage on pin VAFL	$V_{RF} = 1 \text{ mV}$ ; L = R; $\Delta f = 22.5 \text{ kHz}$ ; $f_{mod} = 1 \text{ kHz}$ ; no pre-emphasis; $TC_{deem} = 75 \mu\text{s}$	55	66	75	mV
$V_{VAFR}$	right audio output voltage on pin VAFR	$V_{RF} = 1 \text{ mV}$ ; L = R; $\Delta f = 22.5 \text{ kHz}$ ; $f_{mod} = 1 \text{ kHz}$ ; no pre-emphasis; $TC_{deem} = 75 \mu\text{s}$	55	66	75	mV
$R_{VAFL}$	output resistance on pin VAFL	RDSCDA = 0				
		MU = LHM = RHM = 0	50	-	100	$\Omega$
		MU = LHM = RHM = 1	500	-	-	k $\Omega$
$R_{VAFR}$	output resistance on pin VAFR	RDSCDA = 0				
		MU = LHM = RHM = 0	50	-	100	$\Omega$
		MU = LHM = RHM = 1	500	-	-	k $\Omega$
$I_{sink(VAFL)}$	sink current on pin VAFL		200	-	300	$\mu\text{A}$
$I_{sink(VAFR)}$	sink current on pin VAFR		200	-	300	$\mu\text{A}$
$\alpha_{ODi}$	input overdrive range	THD = 3 % relative to $f_{MPX} = 1 \text{ kHz}$ ; $V_{MPX} = 250 \text{ mV}$	4	-	-	dB
$\Delta V_{O(VAFL-VAFR)}$	output voltage difference between pins VAFL and VAFR	$V_{RF} = 1 \text{ mV}$ ; L = R; $\Delta f = 75 \text{ kHz}$ including 9 % pilot deviation; $f_{mod} = 1 \text{ kHz}$	-0.5	-	+0.5	dB
$\alpha_{cs}$	channel separation	$V_{RF} = 1 \text{ mV}$ ; $\Delta f = 75 \text{ kHz}$ including 9 % pilot deviation; R = 1; L = 0 or R = 0; L = 1; $f_{mod} = 1 \text{ kHz}$ ; MST = 0; SNC = 1; $B_{aud} = 300 \text{ Hz}$ to $15 \text{ kHz}$	27	-	-	dB
$f_u$	upper 3 dB bandwidth	$V_{RF} = 1 \text{ mV}$ ; $\Delta f = 22.5 \text{ kHz}$ ; pre-emphasis = $75 \mu\text{s}$ ; DTC = 0;	13	15	17	kHz
$f_l$	lower 3 dB bandwidth	L = R; with C between pin 27 and pin 26 = $33 \text{ nF} \pm 5 \%$	20	30	50	Hz
(S+N)/N(m)	maximum signal-to-noise ratio, mono	$V_{RF} = 1 \text{ mV}$ ; $\Delta f = 22.5 \text{ kHz}$ ; L = R; $f_{mod} = 1 \text{ kHz}$ ; de-emphasis = $75 \mu\text{s}$ ; $B_{AF} = 300 \text{ Hz}$ to $15 \text{ kHz}$ ; A-weighting filter	54	57	-	dB
(S+N)/N(s)	maximum signal-to-noise ratio, stereo	$V_{RF} = 1 \text{ mV}$ ; $\Delta f = 67.5 \text{ kHz}$ ; L = R; $f_{mod} = 1 \text{ kHz}$ ; $\Delta f_{pilot} = 6.75 \text{ kHz}$ ; de-emphasis = $75 \mu\text{s}$ ; $B_{AF} = 300 \text{ Hz}$ to $15 \text{ kHz}$ ; A-weighting filter	50	54	-	dB

**Table 48: FM signal channel characteristics ...continued**

See [Figure 1](#); all AC values are given in RMS; the min. and max. values include spread due to  $V_{CCA} = V_{CCD} = 2.5 \text{ V}$  to  $3.3 \text{ V}$  and  $T_{amb} = -20^\circ\text{C}$  to  $+85^\circ\text{C}$ ; unless otherwise specified. All RF input values are defined in potential difference, except when EMF is explicitly stated.

Symbol	Parameter	Conditions	Min	Typ	Max	Unit
THD	total harmonic distortion	$V_{RF} = 1 \text{ mV}$ ; $L = 1$ ; $R = 0$ ; $\Delta f = 75 \text{ kHz}$ including 9 % pilot deviation; $f_{mod} = 1 \text{ kHz}$ ; $DTC = 0$ ; $B_{aud} = 300 \text{ Hz}$ to $15 \text{ kHz}$ ; A-weighting filter				
		mono; $L = R$ ; no pilot deviation	-	0.4	0.9	%
		stereo; $L = 1$ , $R = 0$ ; 9 % pilot deviation; see <a href="#">Figure 17</a>	-	0.9	2.5	%
$\alpha_{sup(pilot)}$	pilot suppression	measured at pins VAFL and VAFR; related to $\Delta f = 75 \text{ kHz}$ including 9 % pilot deviation; $f_{mod} = 1 \text{ kHz}$ ; $DTC = 0$	40	50	-	dB
$\Delta f_{pilot}$	pilot frequency deviation	$V_{RF} = 1 \text{ mV}$	<a href="#">Table note [2]</a>			
$\alpha_{hys(pilot)}$	pilot tone detection hysteresis	$V_{RF} = 1 \text{ mV}$	2	-	6	dB
$TC_{deem}$	de-emphasis time constant	$V_{RF} = 1 \text{ mV}$				
		$DTC = 1$	38	50	62	$\mu\text{s}$
		$DTC = 0$	57	75	93	$\mu\text{s}$

**Mono stereo blend; SNC = 1**

$V_{start(blend)}$	blend start voltage	$\alpha_{CS} = 0.5 \text{ dB}$	<a href="#">[3]</a> 2	7	15	$\mu\text{V}$
$\alpha_{CS}$	channel separation	$V_{RF} = 30 \mu\text{V}$ ; $\Delta f = 75 \text{ kHz}$ including 9 % pilot deviation; $R = 1$ and $L = 0$ or $R = 0$ and $L = 1$ ; $f_{mod} = 1 \text{ kHz}$ ; $MST = 0$ ; $SNC = 1$	4	10	16	dB

**Mono stereo switching;  $\Delta f = 75 \text{ kHz}$  including 9 % pilot deviation;  $f_{mod} = 1 \text{ kHz}$ ; SNC = 0**

$\alpha_{CS}$	channel separation	$MST = 0$ ; $R = 1$ and $L = 0$ or $R = 0$ and $L = 1$				
		$V_{RF} = 30 \mu\text{V}$ ; increasing RF input level	27	33	-	dB
		$V_{RF} = 10 \mu\text{V}$ ; decreasing RF input level	-	-	1	dB
$V_{sw}$	switching voltage		<a href="#">[4]</a> 17	25	45	$\mu\text{V}$
hys	hysteresis		<a href="#">[4]</a> 3	3.5	4	dB

**Bus driven mute functions****Tuning mute; AFM = 1**

$\alpha_{mute(VAFR)}$	mute depth on pin VAFR	$AFM = 1$ or $RHM = 1$ ; $\Delta f = 75 \text{ kHz}$ ; mono; $B_{aud} = 300 \text{ Hz}$ to $15 \text{ kHz}$ ; A-weighting filter	-60	-	-	dB
$\alpha_{mute(VAFL)}$	mute depth on pin VAFL	$AFM = 1$ or $LHM = 1$ ; $\Delta f = 75 \text{ kHz}$ ; mono; $B_{aud} = 300 \text{ Hz}$ to $15 \text{ kHz}$ ; A-weighting filter	-60	-	-	dB
$\alpha_{mute}$	mute depth on pins VAFL and VAFR	$MU = 1$ ; $\Delta f = 75 \text{ kHz}$ ; mono; $B_{aud} = 300 \text{ Hz}$ to $15 \text{ kHz}$ ; A-weighting filter	-80	-	-	dB

**Table 48: FM signal channel characteristics ...continued**

See [Figure 1](#); all AC values are given in RMS; the min. and max. values include spread due to  $V_{CCA} = V_{CCD} = 2.5\text{ V}$  to  $3.3\text{ V}$  and  $T_{amb} = -20\text{ }^{\circ}\text{C}$  to  $+85\text{ }^{\circ}\text{C}$ ; unless otherwise specified. All RF input values are defined in potential difference, except when EMF is explicitly stated.

Symbol	Parameter	Conditions	Min	Typ	Max	Unit
RDS demodulator/decoder; $\Delta f = 22.5\text{ kHz}$ ; $f_{AF} = 1\text{ kHz}$ ; L = R; $TC_{deem} = 50\text{ }\mu\text{s}$ ; DTC = 1; SYM1 = 0 and SYM0 = 0; average over 2000 blocks						
$I_{RDS}$	RDS current	$I_{CCD}$ current when RDS is running	0.3	0.7	1.5	mA
$V_{sens}$	RDS sensitivity EMF value	$\Delta f = 22.5\text{ kHz}$ ; $f_{AF} = 1\text{ kHz}$ ; L = R; SYM1 = 0 and SYM0 = 0				
		block quality rate $\geq 85\%$ ; $\Delta f_{RDS} = 1.2\text{ kHz}$	-	24.7	32.5	$\mu\text{V}$
		block quality rate $\geq 95\%$ ; $\Delta f_{RDS} = 2\text{ kHz}$	-	15	26	$\mu\text{V}$
$f_{center}$	filter center frequency		56.5	57	57.5	kHz
B	Bandwidth		2.5	3	3.5	kHz
<b>Pause detector</b>						
$f_{th(det)(pause)}$	pause detection threshold frequency	$f_{mod} = 1\text{ kHz}$ ; L = R; PL0 = 0; PL1 = 0	0.7	1.0	1.4	kHz

- [1] Low-side and high-side selectivity can be measured by changing the mixer LO injection from high-side to low-side.
- [2] When bit STEREO is at logic 1 the frequency is between 2.5 kHz and 5.8 kHz; when bit STEREO is at logic 0 the frequency is 0 kHz.
- [3] With increasing input levels the radio switches gradually from mono to stereo.
- [4] The mono stereo switching level is the RF input level for switching from mono to stereo.

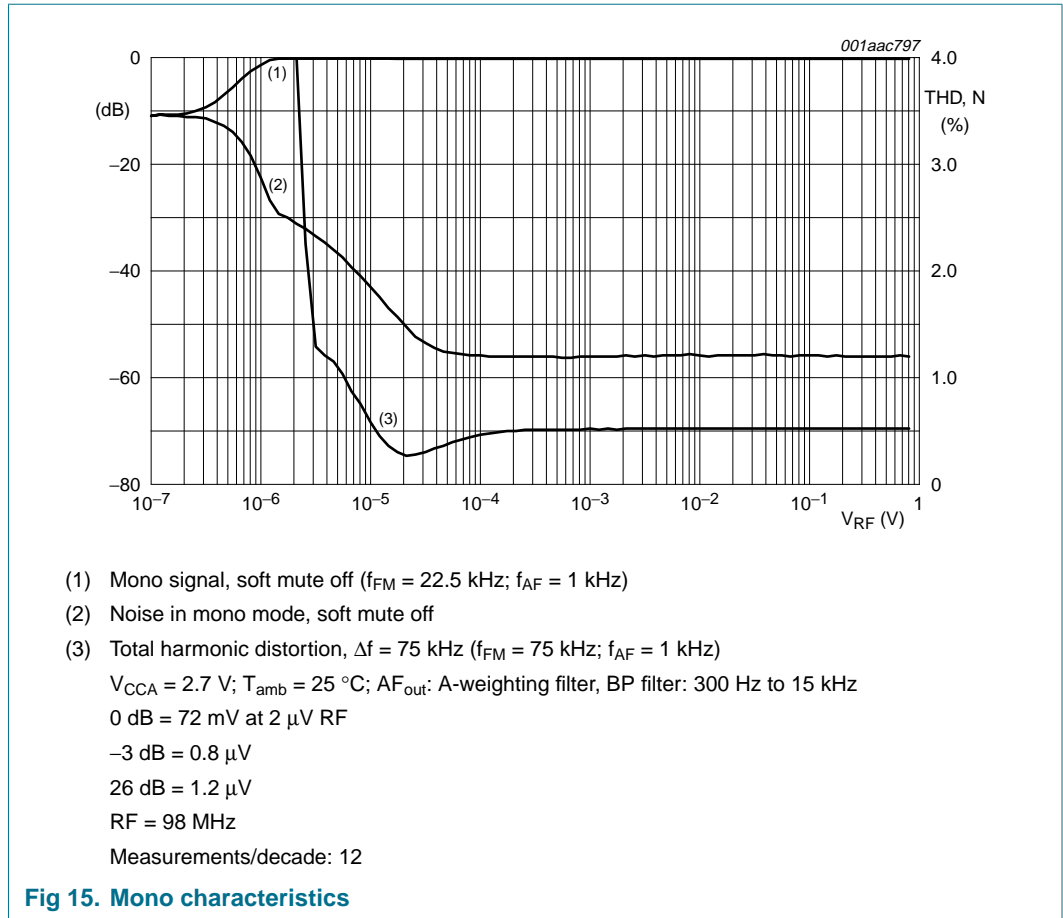

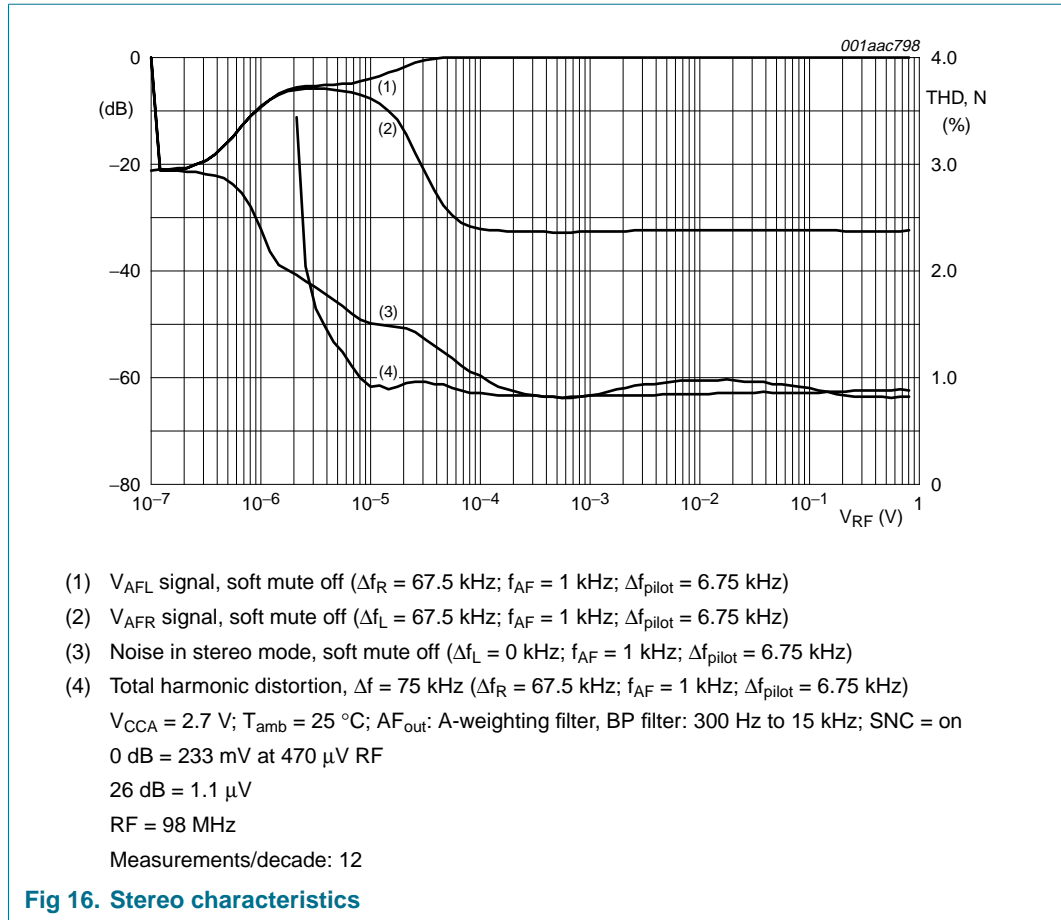

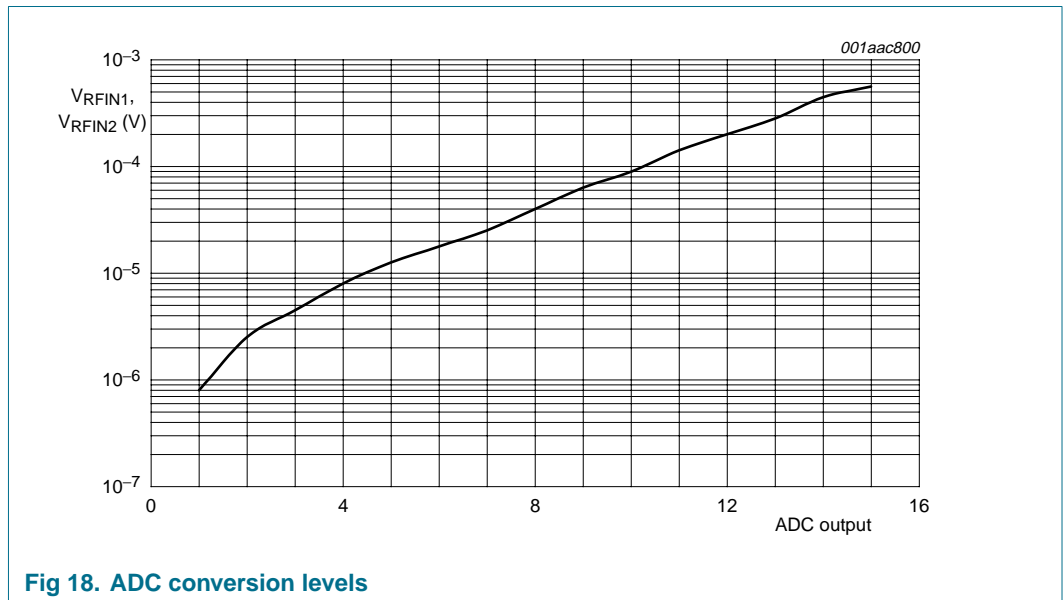
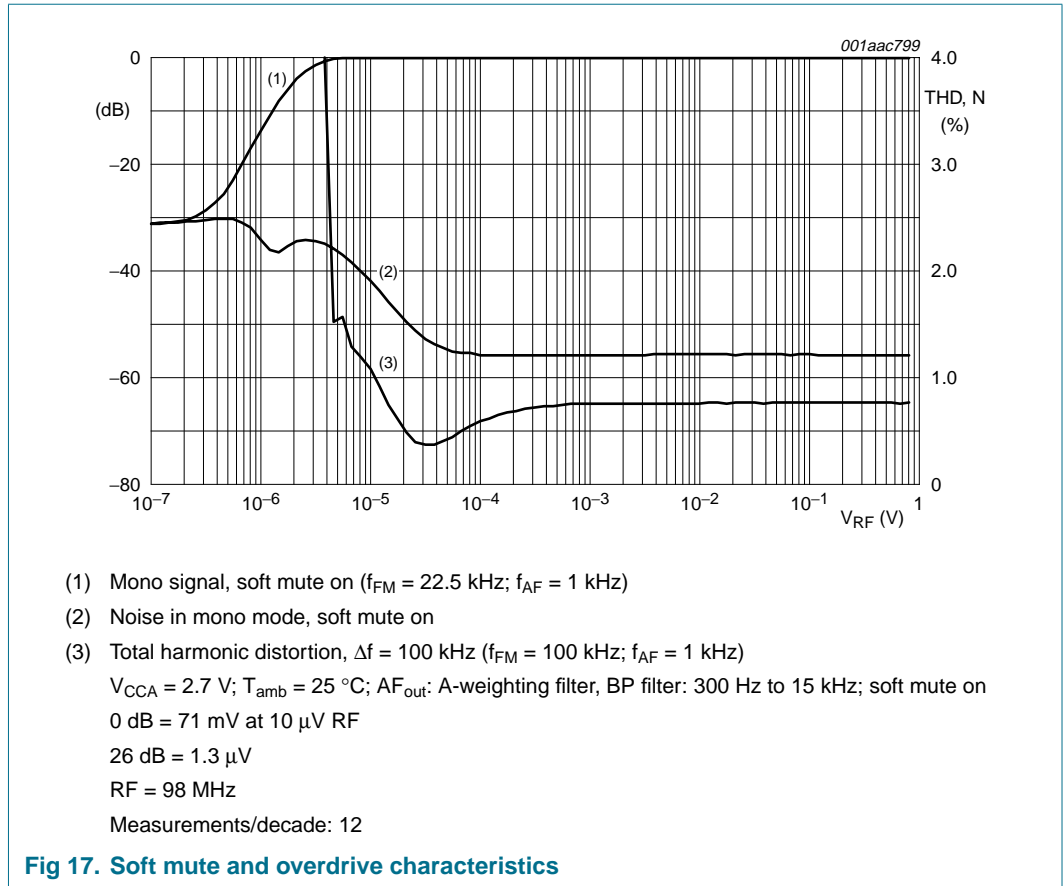

## 16. Application information

**Table 49: List of components**

Symbol	Parameter	Type	Manufacturer
D1, D2	varicap diode for VCO tuning	BB202	Philips
L1	RF band filter coil	120 nH; $Q_{\min} = 20$ ; tolerance: $\pm 5\%$	Coilcraft; Murata
L2, L3	VCO coil	33 nH; $Q_{\min} = 40$ ; tolerance: $\pm 2\%$	Coilcraft; Murata
X1	32.768 kHz crystal	ACT200; $C_L = 12$ pF; $\Delta f/f_0 = \pm 20$ ppm; see <a href="#">Section 15</a>	ACT
R	10 k $\Omega$ ; 47 k $\Omega$ ; 100 k $\Omega$	$\pm 10\%$ max	
C	27 pF; 47 pF; 100 pF; 12 pF; 10 nF(2 $\times$ ); 33 nF(8 $\times$ )	$\pm 10\%$ max	



17. Package outline

HVQFN40: plastic thermal enhanced very thin quad flat package; no leads; 40 terminals; body 6 x 6 x 0.85 mm

SOT618-1

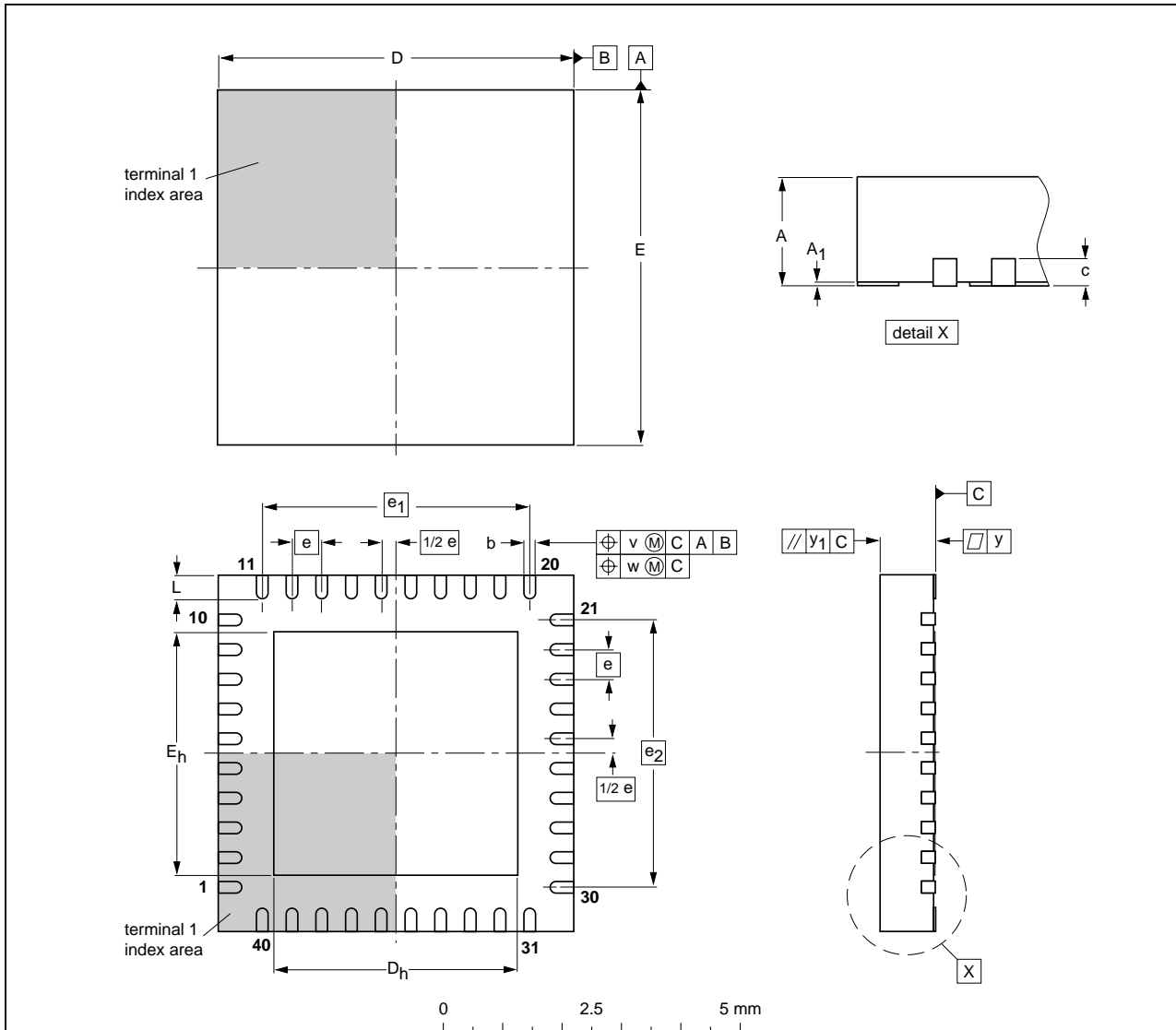

DIMENSIONS (mm are the original dimensions)

UNIT	A <sup>(1)</sup> max.	A <sub>1</sub>	b	c	D <sup>(1)</sup>	D <sub>h</sub>	E <sup>(1)</sup>	E <sub>h</sub>	e	e <sub>1</sub>	e <sub>2</sub>	L	v	w	y	y <sub>1</sub>
mm	1	0.05 0.00	0.30 0.18	0.2	6.1 5.9	4.25 3.95	6.1 5.9	4.25 3.95	0.5	4.5	4.5	0.5 0.3	0.1	0.05	0.05	0.1

Note

1. Plastic or metal protrusions of 0.075 mm maximum per side are not included.

OUTLINE VERSION	REFERENCES				EUROPEAN PROJECTION	ISSUE DATE
	IEC	JEDEC	JEITA			
SOT618-1	---	MO-220	---			01-08-08 02-10-22

Fig 19. Package outline SOT618-1 (HVQFN40)

## 18. Soldering

### 18.1 Introduction to soldering surface mount packages

This text gives a very brief insight to a complex technology. A more in-depth account of soldering ICs can be found in our *Data Handbook IC26; Integrated Circuit Packages* (document order number 9398 652 90011).

There is no soldering method that is ideal for all surface mount IC packages. Wave soldering can still be used for certain surface mount ICs, but it is not suitable for fine pitch SMDs. In these situations reflow soldering is recommended.

### 18.2 Reflow soldering

Reflow soldering requires solder paste (a suspension of fine solder particles, flux and binding agent) to be applied to the printed-circuit board by screen printing, stencilling or pressure-syringe dispensing before package placement. Driven by legislation and environmental forces the worldwide use of lead-free solder pastes is increasing.

Several methods exist for reflowing; for example, convection or convection/infrared heating in a conveyor type oven. Throughput times (preheating, soldering and cooling) vary between 100 seconds and 200 seconds depending on heating method.

Typical reflow peak temperatures range from 215 °C to 270 °C depending on solder paste material. The top-surface temperature of the packages should preferably be kept:

- below 225 °C (SnPb process) or below 245 °C (Pb-free process)
  - for all BGA, HTSSON..T and SSOP..T packages
  - for packages with a thickness  $\geq 2.5$  mm
  - for packages with a thickness  $< 2.5$  mm and a volume  $\geq 350$  mm<sup>3</sup> so called thick/large packages.
- below 240 °C (SnPb process) or below 260 °C (Pb-free process) for packages with a thickness  $< 2.5$  mm and a volume  $< 350$  mm<sup>3</sup> so called small/thin packages.

Moisture sensitivity precautions, as indicated on packing, must be respected at all times.

### 18.3 Wave soldering

Conventional single wave soldering is not recommended for surface mount devices (SMDs) or printed-circuit boards with a high component density, as solder bridging and non-wetting can present major problems.

To overcome these problems the double-wave soldering method was specifically developed.

If wave soldering is used the following conditions must be observed for optimal results:

- Use a double-wave soldering method comprising a turbulent wave with high upward pressure followed by a smooth laminar wave.
- For packages with leads on two sides and a pitch (e):
  - larger than or equal to 1.27 mm, the footprint longitudinal axis is **preferred** to be parallel to the transport direction of the printed-circuit board;

- smaller than 1.27 mm, the footprint longitudinal axis **must** be parallel to the transport direction of the printed-circuit board.

The footprint must incorporate solder thieves at the downstream end.

- For packages with leads on four sides, the footprint must be placed at a 45° angle to the transport direction of the printed-circuit board. The footprint must incorporate solder thieves downstream and at the side corners.

During placement and before soldering, the package must be fixed with a droplet of adhesive. The adhesive can be applied by screen printing, pin transfer or syringe dispensing. The package can be soldered after the adhesive is cured.

Typical dwell time of the leads in the wave ranges from 3 seconds to 4 seconds at 250 °C or 265 °C, depending on solder material applied, SnPb or Pb-free respectively.

A mildly-activated flux will eliminate the need for removal of corrosive residues in most applications.

### 18.4 Manual soldering

Fix the component by first soldering two diagonally-opposite end leads. Use a low voltage (24 V or less) soldering iron applied to the flat part of the lead. Contact time must be limited to 10 seconds at up to 300 °C.

When using a dedicated tool, all other leads can be soldered in one operation within 2 seconds to 5 seconds between 270 °C and 320 °C.

### 18.5 Package related soldering information

**Table 50: Suitability of surface mount IC packages for wave and reflow soldering methods**

Package [1]	Soldering method	
	Wave	Reflow [2]
BGA, HTSSON..T [3], LBGA, LFBGA, SQFP, SSOP..T [3], TFBGA, VFBGA, XSON	not suitable	suitable
DHVQFN, HBCC, HBGA, HLQFP, HSO, HSOP, HSQFP, HSSON, HTQFP, HTSSOP, HVQFN, HVSON, SMS	not suitable [4]	suitable
PLCC [5], SO, SOJ	suitable	suitable
LQFP, QFP, TQFP	not recommended [5] [6]	suitable
SSOP, TSSOP, VSO, VSSOP	not recommended [7]	suitable
CWQCCN..L [8], PMFP [9], WQCCN..L [8]	not suitable	not suitable

[1] For more detailed information on the BGA packages refer to the *(LF)BGA Application Note (AN01026)*; order a copy from your Philips Semiconductors sales office.

[2] All surface mount (SMD) packages are moisture sensitive. Depending upon the moisture content, the maximum temperature (with respect to time) and body size of the package, there is a risk that internal or external package cracks may occur due to vaporization of the moisture in them (the so called popcorn effect). For details, refer to the Drypack information in the *Data Handbook IC26; Integrated Circuit Packages; Section: Packing Methods*.

[3] These transparent plastic packages are extremely sensitive to reflow soldering conditions and must on no account be processed through more than one soldering cycle or subjected to infrared reflow soldering with peak temperature exceeding 217 °C ± 10 °C measured in the atmosphere of the reflow oven. The package body peak temperature must be kept as low as possible.

- [4] These packages are not suitable for wave soldering. On versions with the heatsink on the bottom side, the solder cannot penetrate between the printed-circuit board and the heatsink. On versions with the heatsink on the top side, the solder might be deposited on the heatsink surface.
- [5] If wave soldering is considered, then the package must be placed at a 45° angle to the solder wave direction. The package footprint must incorporate solder thieves downstream and at the side corners.
- [6] Wave soldering is suitable for LQFP, QFP and TQFP packages with a pitch (e) larger than 0.8 mm; it is definitely not suitable for packages with a pitch (e) equal to or smaller than 0.65 mm.
- [7] Wave soldering is suitable for SSOP, TSSOP, VSO and VSSOP packages with a pitch (e) equal to or larger than 0.65 mm; it is definitely not suitable for packages with a pitch (e) equal to or smaller than 0.5 mm.
- [8] Image sensor packages in principle should not be soldered. They are mounted in sockets or delivered pre-mounted on flex foil. However, the image sensor package can be mounted by the client on a flex foil by using a hot bar soldering process. The appropriate soldering profile can be provided on request.
- [9] Hot bar soldering or manual soldering is suitable for PMFP packages.

## 19. Revision history

**Table 51: Revision history**

Document ID	Release date	Data sheet status	Change notice	Doc. number	Supersedes
TEA5764HN_2	20050809	Product data sheet	-	-	TEA5764HN_1
Modifications:	• Specification status changed from objective data sheet to product data sheet.				
TEA5764HN_1	20050707	Objective data sheet	-	9397 750 13453	-

## 20. Data sheet status

Level	Data sheet status <sup>[1]</sup>	Product status <sup>[2] [3]</sup>	Definition
I	Objective data	Development	This data sheet contains data from the objective specification for product development. Philips Semiconductors reserves the right to change the specification in any manner without notice.
II	Preliminary data	Qualification	This data sheet contains data from the preliminary specification. Supplementary data will be published at a later date. Philips Semiconductors reserves the right to change the specification without notice, in order to improve the design and supply the best possible product.
III	Product data	Production	This data sheet contains data from the product specification. Philips Semiconductors reserves the right to make changes at any time in order to improve the design, manufacturing and supply. Relevant changes will be communicated via a Customer Product/Process Change Notification (CPCN).

[1] Please consult the most recently issued data sheet before initiating or completing a design.

[2] The product status of the device(s) described in this data sheet may have changed since this data sheet was published. The latest information is available on the Internet at URL <http://www.semiconductors.philips.com>.

[3] For data sheets describing multiple type numbers, the highest-level product status determines the data sheet status.

## 21. Definitions

**Short-form specification** — The data in a short-form specification is extracted from a full data sheet with the same type number and title. For detailed information see the relevant data sheet or data handbook.

**Limiting values definition** — Limiting values given are in accordance with the Absolute Maximum Rating System (IEC 60134). Stress above one or more of the limiting values may cause permanent damage to the device. These are stress ratings only and operation of the device at these or at any other conditions above those given in the Characteristics sections of the specification is not implied. Exposure to limiting values for extended periods may affect device reliability.

**Application information** — Applications that are described herein for any of these products are for illustrative purposes only. Philips Semiconductors make no representation or warranty that such applications will be suitable for the specified use without further testing or modification.

## 22. Disclaimers

**Life support** — These products are not designed for use in life support appliances, devices, or systems where malfunction of these products can reasonably be expected to result in personal injury. Philips Semiconductors

## 24. Contact information

For additional information, please visit: <http://www.semiconductors.philips.com>

For sales office addresses, send an email to: [sales.addresses@www.semiconductors.philips.com](mailto:sales.addresses@www.semiconductors.philips.com)

customers using or selling these products for use in such applications do so at their own risk and agree to fully indemnify Philips Semiconductors for any damages resulting from such application.

**Right to make changes** — Philips Semiconductors reserves the right to make changes in the products - including circuits, standard cells, and/or software - described or contained herein in order to improve design and/or performance. When the product is in full production (status 'Production'), relevant changes will be communicated via a Customer Product/Process Change Notification (CPCN). Philips Semiconductors assumes no responsibility or liability for the use of any of these products, conveys no license or title under any patent, copyright, or mask work right to these products, and makes no representations or warranties that these products are free from patent, copyright, or mask work right infringement, unless otherwise specified.

## 23. Trademarks

**Notice** — All referenced brands, product names, service names and trademarks are the property of their respective owners.

**I<sup>2</sup>C-bus** — wordmark and logo are trademarks of Koninklijke Philips Electronics N.V.

## 25. Contents

<b>1</b>	<b>General description</b> . . . . .	<b>1</b>	<b>9</b>	<b>Interrupt handling</b> . . . . .	<b>16</b>
<b>2</b>	<b>Features</b> . . . . .	<b>1</b>	9.1	Interrupt register . . . . .	16
<b>3</b>	<b>Applications</b> . . . . .	<b>2</b>	9.1.1	Interrupt clearing . . . . .	17
<b>4</b>	<b>Quick reference data</b> . . . . .	<b>2</b>	9.1.2	Timing . . . . .	17
<b>5</b>	<b>Ordering information</b> . . . . .	<b>3</b>	9.1.3	Reset . . . . .	17
<b>6</b>	<b>Block diagram</b> . . . . .	<b>4</b>	9.1.4	Interrupt flags and behavior . . . . .	19
<b>7</b>	<b>Pinning information</b> . . . . .	<b>5</b>	9.1.4.1	Multiple interrupt events . . . . .	19
7.1	Pinning . . . . .	5	9.1.4.2	Data available flag . . . . .	19
7.2	Pin description . . . . .	5	9.1.4.3	RDS synchronization flag . . . . .	19
<b>8</b>	<b>Functional description</b> . . . . .	<b>6</b>	9.1.4.4	IF frequency flag . . . . .	20
8.1	Low noise RF amplifier . . . . .	6	9.1.4.5	RSSI threshold flag . . . . .	20
8.2	FM I/Q mixer . . . . .	6	9.1.4.6	Pause detection flag . . . . .	21
8.3	VCO . . . . .	6	9.1.4.7	Frequency ready flag . . . . .	22
8.4	Crystal oscillator . . . . .	7	9.1.4.8	Band limit flag . . . . .	23
8.5	PLL tuning system . . . . .	7	9.2	Interrupt output . . . . .	23
8.6	Band limits . . . . .	8	<b>10</b>	<b>RDS data processing</b> . . . . .	<b>23</b>
8.7	RF AGC . . . . .	8	10.1	DAV-A processing mode . . . . .	24
8.8	Local or long distance receive . . . . .	8	10.2	DAV-B processing mode / fast PI search mode . . . . .	25
8.9	IF filter . . . . .	8	10.3	DAV-C reduced processing mode . . . . .	26
8.10	FM demodulator . . . . .	8	10.4	Synchronization . . . . .	28
8.11	IF counter . . . . .	8	10.4.1	Conditions for synchronization . . . . .	28
8.12	Voltage level generator and analog-to-digital converter . . . . .	9	10.4.2	Data overflow . . . . .	29
8.13	Mute . . . . .	9	10.5	RDS flag behavior during read action . . . . .	30
8.13.1	Soft mute . . . . .	9	10.6	Error detection and reporting . . . . .	31
8.13.2	Hard mute . . . . .	9	10.7	RDS test modes . . . . .	31
8.13.3	Audio frequency mute . . . . .	9	10.8	Reading RDS data from the registers . . . . .	31
8.14	MPX decoder . . . . .	9	<b>11</b>	<b>I<sup>2</sup>C-bus interface</b> . . . . .	<b>31</b>
8.15	Signal dependent mono/stereo blend (stereo noise cancellation) . . . . .	10	11.1	Write and read mode . . . . .	31
8.16	Software programmable port . . . . .	10	11.2	Data transfer . . . . .	32
8.17	Standby mode . . . . .	10	11.3	Register map . . . . .	34
8.18	Power-on reset . . . . .	10	11.4	Byte description . . . . .	34
8.19	RDS/RBDS . . . . .	10	<b>12</b>	<b>Limiting values</b> . . . . .	<b>45</b>
8.19.1	RDS/RBDS demodulator . . . . .	10	<b>13</b>	<b>Thermal characteristics</b> . . . . .	<b>45</b>
8.19.2	RDS data and clock direct . . . . .	11	<b>14</b>	<b>Static characteristics</b> . . . . .	<b>46</b>
8.19.2.1	RDS/RBDS decoder . . . . .	11	<b>15</b>	<b>Dynamic characteristics</b> . . . . .	<b>47</b>
8.20	Audio pause detector . . . . .	11	<b>16</b>	<b>Application information</b> . . . . .	<b>56</b>
8.21	Auto search and Preset mode . . . . .	11	<b>17</b>	<b>Package outline</b> . . . . .	<b>57</b>
8.21.1	Search mode . . . . .	13	<b>18</b>	<b>Soldering</b> . . . . .	<b>58</b>
8.21.2	Preset mode . . . . .	13	18.1	Introduction to soldering surface mount packages . . . . .	58
8.21.3	Auto high-side and low-side injection stop switch . . . . .	14	18.2	Reflow soldering . . . . .	58
8.21.4	Muting during search or preset . . . . .	14	18.3	Wave soldering . . . . .	58
8.22	RDS update/alternative frequency jump . . . . .	14	18.4	Manual soldering . . . . .	59
8.22.1	Muting during RDS update . . . . .	15	18.5	Package related soldering information . . . . .	59
			<b>19</b>	<b>Revision history</b> . . . . .	<b>61</b>
			<b>20</b>	<b>Data sheet status</b> . . . . .	<b>62</b>

continued >>

21	Definitions .....	62
22	Disclaimers .....	62
23	Trademarks .....	62
24	Contact information .....	62



© Koninklijke Philips Electronics N.V. 2005

All rights are reserved. Reproduction in whole or in part is prohibited without the prior written consent of the copyright owner. The information presented in this document does not form part of any quotation or contract, is believed to be accurate and reliable and may be changed without notice. No liability will be accepted by the publisher for any consequence of its use. Publication thereof does not convey nor imply any license under patent- or other industrial or intellectual property rights.

Date of release: 9 August 2005  
Document number: TEA5764HN\_2

Published in The Netherlands