

# MIC2571

## Single-Cell Switching Regulator

### Preliminary Information

## General Description

Micrel's MIC2571 is a micropower boost switching regulator that operates from one alkaline, nickel-metal-hydride cell, or lithium cell.

The MIC2571 accepts a positive input voltage between 0.9V and 15V. Its typical no-load supply current is 120 $\mu$ A.

The MIC2571 is available in selectable fixed output or adjustable output versions. The MIC2571-1 can be configured for 2.85V, 3.3V, or 5V by connecting one of three separate feedback pins to the output. The MIC2571-2 can be configured for an output voltage ranging between its input voltage and 36V, using an external resistor network.

The MIC2571 has a fixed switching frequency of 20kHz. An external SYNC connection allows the switching frequency to be synchronized to an external signal.

The MIC2571 requires only four components (diode, inductor, input capacitor and output capacitor) to implement a boost regulator. A complete regulator can be constructed in a 0.3 in<sup>2</sup> area.

All versions are available in an 8-lead MSOP with an operating range from -40°C to +85°.

## Features

- Operates from a single-cell supply  
0.9V to 15V operation
- 120 $\mu$ A typical quiescent current
- Complete regulator fits 0.3 in<sup>2</sup> area
- 2.85V/3.3V/5V selectable output voltage (MIC2571-1)
- Adjustable output up to 36V (MIC2571-2)
- 1A current limited pass element
- Frequency synchronization input
- 8-lead MSOP package

## Applications

- Pagers
- LCD bias generator
- Battery-powered, hand-held instruments
- Palmtop computers
- Remote controls
- Detectors
- Battery Backup Supplies

## Typical Applications

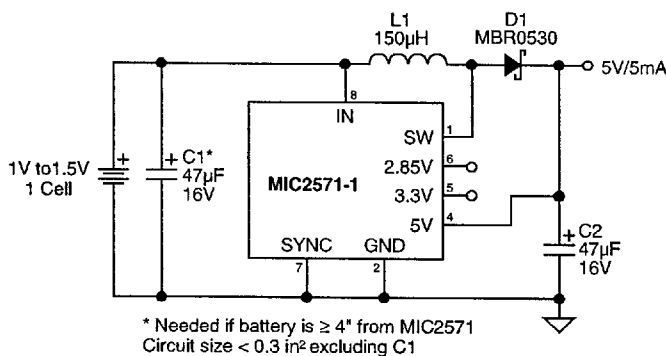

Single-Cell to 5V DC-to-DC Converter

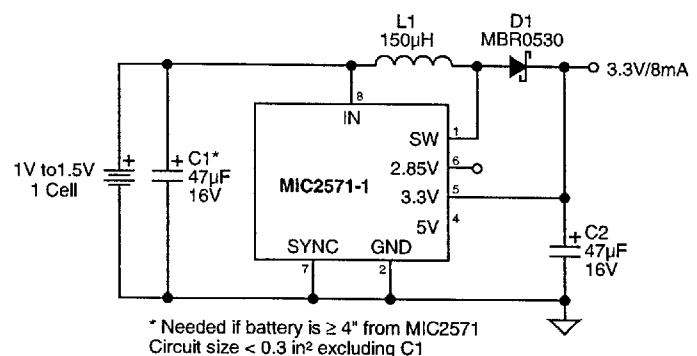

Single-Cell to 3.3V DC-to-DC Converter

## Ordering Information

Part Number	Temperature Range	Voltage	Frequency	Package
MIC2571-1BMM	-40°C to +85°C	Selectable*	20kHz	8-lead MSOP
MIC2571-2BMM	-40°C to +85°C	Adjustable	20kHz	8-lead MSOP

\* Externally selectable for 2.85V, 3.3V, or 5V

## Pin Configuration

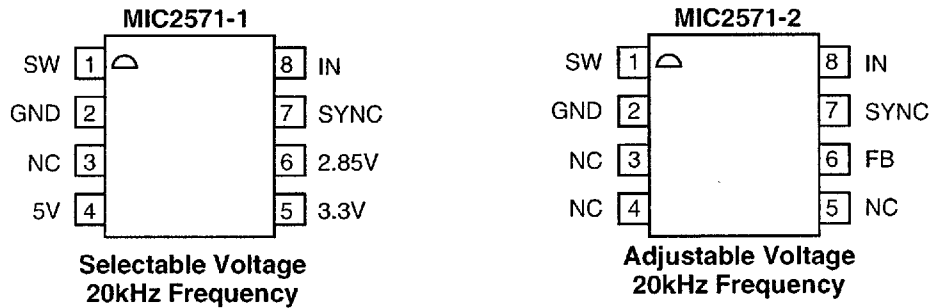

### 8-Lead MSOP (MM)

## Pin Description

Pin No. (Version†)	Pin Name	Pin Function
1	SW	Switch: NPN output switch transistor collector.
2	GND	Power Ground: NPN output switch transistor emitter.
3	NC	Not internally connected.
4 (-1)	5V	5V Feedback (Input): Fixed 5V feedback to internal resistive divider.
4 (-2)	NC	Not internally connected.
5 (-1)	3.3V	3.3V Feedback (Input): Fixed 3.3V feedback to internal resistive divider.
5 (-2)	NC	Not internally connected.
6 (-1)	2.85V	2.85V Feedback (Input): Fixed 2.85V feedback to internal resistive divider.
6 (-2)	FB	Feedback (Input): 0.22V feedback from external voltage divider network.
7	SYNC	Synchronization (Input): Oscillator start timing. Oscillator synchronizes to falling edge of sync signal.
8	IN	Supply (Input): Positive supply voltage input.

† Example: (-1) indicates the pin description is applicable to the MIC2571-1 only.

**Absolute Maximum Ratings**

Supply Voltage ( $V_{IN}$ )	18V
Switch Voltage ( $V_{SW}$ )	36V
Switch Current ( $I_{SW}$ )	1A
Sync Voltage ( $V_{SYNC}$ )	-0.3V to 15V
Storage Temperature ( $T_A$ )	-65°C to +150°C
MSOP Power Dissipation ( $P_D$ )	250mW

**Operating Ratings**

Supply Voltage ( $V_{IN}$ )	+0.9V to +15V
Ambient Operating Temperature ( $T_A$ )	-40°C to +85°C
Junction Temperature ( $T_J$ )	-40°C to +125°C
MSOP Thermal Resistance ( $\theta_{JA}$ )	240°C/W

**Electrical Characteristics**

$V_{IN} = 1.5V$ ;  $T_A = 25^\circ C$ , **bold** indicates  $-40^\circ C \leq T_A \leq 85^\circ C$ ; unless noted

Parameter	Condition	Min	Typ	Max	Units
Input Voltage	Startup guaranteed, $I_{SW} = 100mA$	0.9		15	V V
Quiescent Current	Output switch off		120		$\mu A$
Fixed Feedback Voltage	MIC2571-1; $V_{2.85V\ pin} = V_{OUT}$ , $I_{SW} = 100mA$ MIC2571-1; $V_{3.3V\ pin} = V_{OUT}$ , $I_{SW} = 100mA$ MIC2571-1; $V_{5V\ pin} = V_{OUT}$ , $I_{SW} = 100mA$		2.85 3.30 5.00		V V V
Reference Voltage	MIC2571-2, [adj. voltage versions], $I_{SW} = 100mA$ , <b>Note 1</b>		220 <b>220</b>		mV mV
Comparator Hysteresis	MIC2571-2, [adj. voltage versions]		6		mV
Output Hysteresis	MIC2571-1; $V_{2.85V\ pin} = V_{OUT}$ , $I_{SW} = 100mA$ MIC2571-1; $V_{3.3V\ pin} = V_{OUT}$ , $I_{SW} = 100mA$ MIC2571-1; $V_{5V\ pin} = V_{OUT}$ , $I_{SW} = 100mA$		65 75 120		mV mV mV
Feedback Current	MIC2571-1; $V_{2.85V\ pin} = V_{OUT}$ MIC2571-1; $V_{3.3V\ pin} = V_{OUT}$ MIC2571-1; $V_{5V\ pin} = V_{OUT}$ MIC2571-2, [adj. voltage versions]; $V_{FB} = 0V$		4.5 4.5 4.5 25		$\mu A$ $\mu A$ $\mu A$ nA
Reference Line Regulation	$1.0V \leq V_{IN} \leq 12V$		0.35		%/V
Switch Saturation Voltage	$V_{IN} = 1.0V$ , $I_{SW} = 200mA$ $V_{IN} = 1.2V$ , $I_{SW} = 600mA$ $V_{IN} = 1.5V$ , $I_{SW} = 800mA$		200 400 500		mV mV mV
Switch Leakage Current	Output switch off, $V_{SW} = 36V$		1		$\mu A$
Oscillator Frequency	MIC2571-1, -2; $I_{SW} = 100mA$		20		kHz
Maximum Output Voltage				36	V
Sync Threshold Voltage			0.7		V
Switch On Time			35		$\mu s$
Current Limit			1.1		A
Duty Cycle	$V_{FB} < V_{REF}$ , $I_{SW} = 100mA$		67		%

**General Note:** Devices are ESD protected; however, handling precautions are recommended.

**Note 1:** Measured using comparator trip point.

# Typical Characteristics

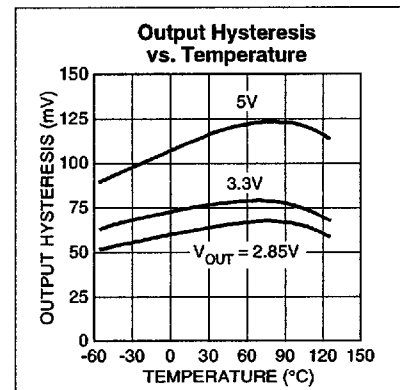
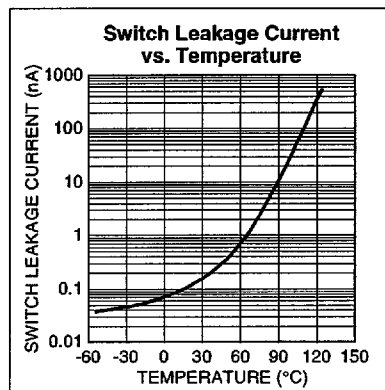
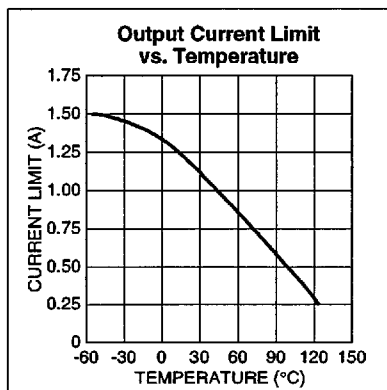
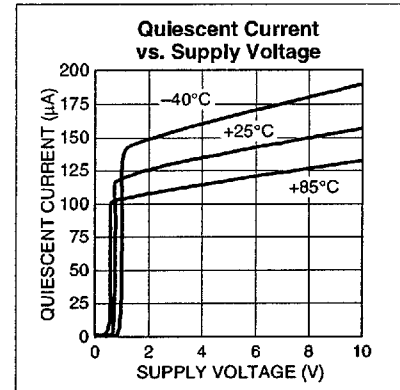
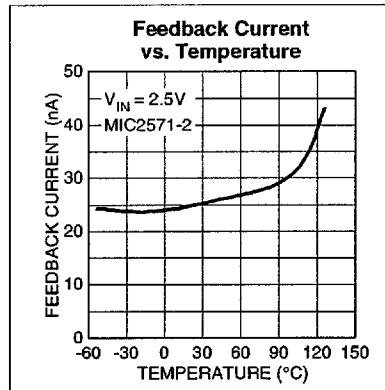
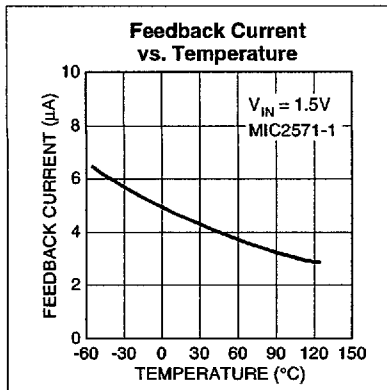
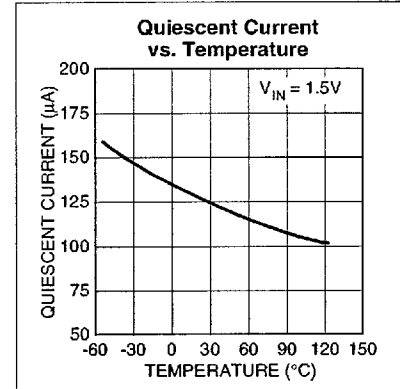
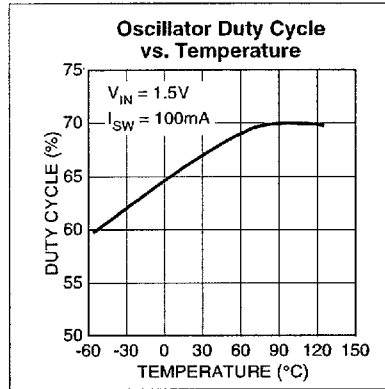
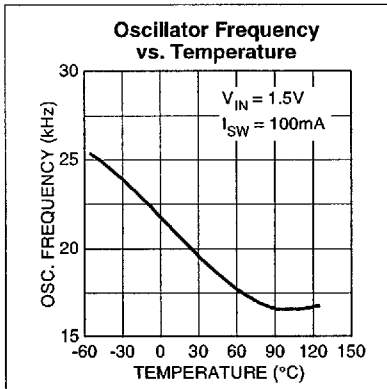
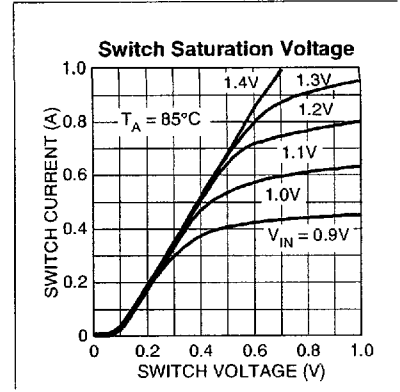
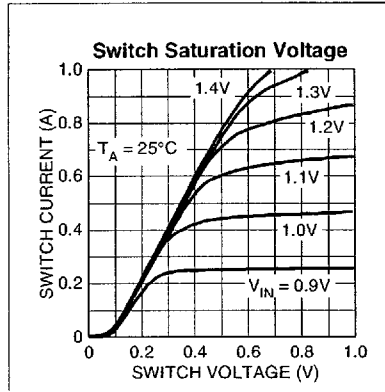
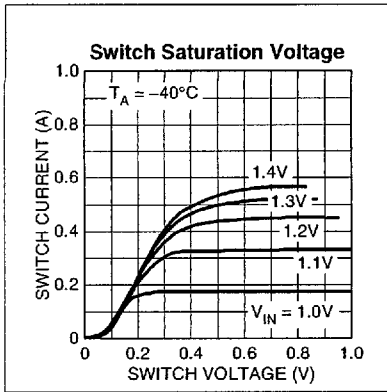

**Block Diagrams**

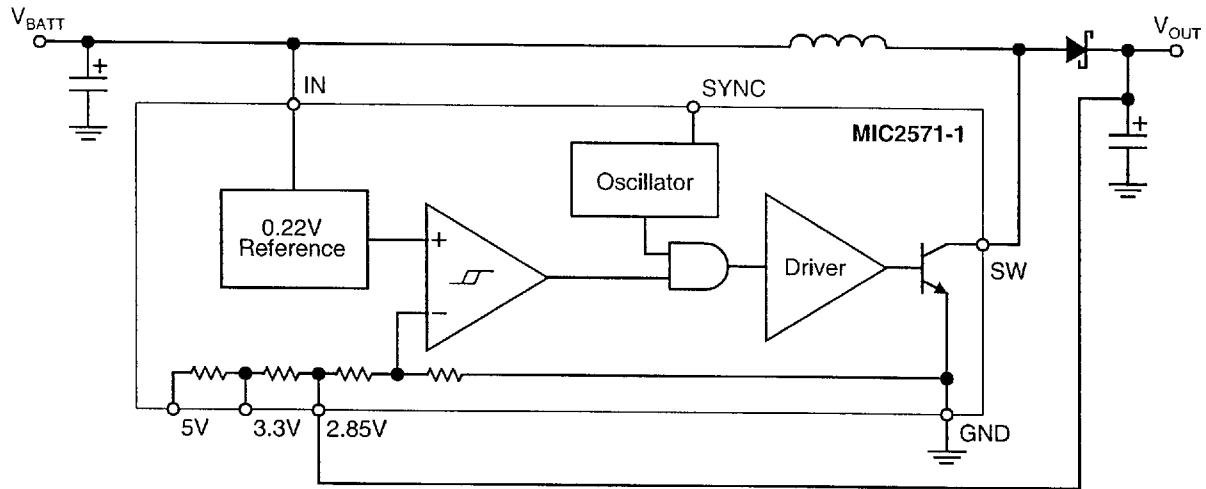

**Selectable Voltage Version with External Components**

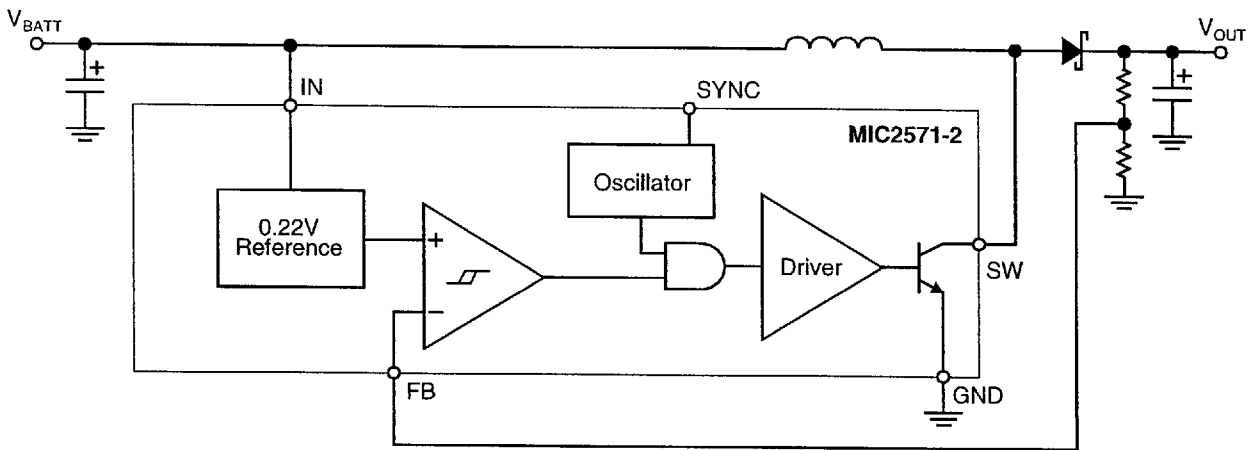

**Adjustable Voltage Version with External Components**

## Functional Description

The MIC2571 switch-mode power supply (SMPS) is a gated oscillator architecture designed to operate from an input voltage as low as 0.9V and provide a high-efficiency fixed or adjustable regulated output voltage. One advantage of this architecture is that the output switch is disabled whenever the output voltage is above the feedback comparator threshold thereby greatly reducing quiescent current and improving efficiency, especially at low output currents.

Refer to the Block Diagrams for the following description of typical gated oscillator boost regulator function.

The bandgap reference provides a constant 0.22V over a wide range of input voltage and junction temperature. The comparator senses the output voltage through an internal or external resistor divider and compares it to the bandgap reference voltage.

When the voltage at the inverting input of the comparator is below 0.22V, the comparator output is high and the output of the oscillator is allowed to pass through the AND gate to the output driver and output switch. The output switch then turns on and off storing energy in the inductor. When the output switch is on (low) energy is stored in the inductor; when the switch is off (high) the stored energy is dumped into the output capacitor which causes the output voltage to rise.

When the output voltage is high enough to cause the comparator output to be low (inverting input voltage is above 0.22V) the AND gate is disabled and the output switch remains off (high). The output switch remains disabled until the output voltage falls low enough to cause the comparator output to go high.

There is about 6mV of hysteresis built into the comparator to prevent jitter about the switch point. Due to the gain of the feedback resistor divider the voltage at  $V_{OUT}$  experiences about 120mV of hysteresis for a 5V output.

## Applications Information

### Oscillator Duty Cycle and Frequency

The oscillator duty cycle is set to 67% which is optimized to provide maximum load current for output voltages approximately 3× larger than the input voltage. Other output voltages are also easily generated but at a small cost in efficiency. The fixed oscillator frequency (options -1 and -2) is set to 20kHz.

### Output Waveforms

The voltage waveform seen at the collector of the output switch (SW pin) is either a continuous value equal to  $V_{IN}$  or a switching waveform running at a frequency and duty cycle set by the oscillator. The continuous voltage equal to  $V_{IN}$  happens when the voltage at the output ( $V_{OUT}$ ) is high enough to cause the comparator to disable the AND gate. In this state the output switch is off and no switching of the inductor occurs. When  $V_{OUT}$  drops low enough to cause the comparator output to change to the high state the output switch is driven by the oscillator. See Figure 1 for typical voltage waveforms in a boost application.

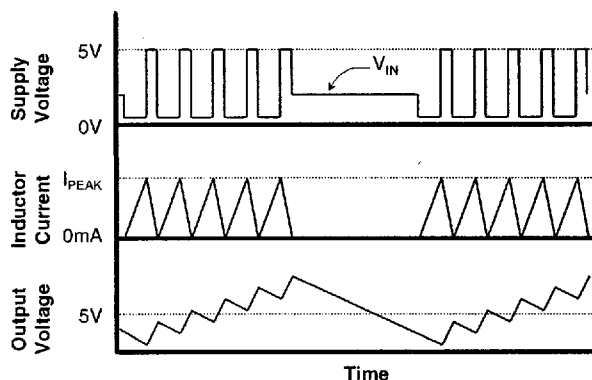

Figure 1. Typical Boost Regulator Waveforms

### Synchronization

The SYNC pin is used to synchronize the MIC2571 to an external oscillator or clock signal. This can reduce system noise by correlating switching noise with a known system frequency. When not in use, the SYNC pin should be grounded to prevent spurious circuit operation. A falling edge at the SYNC input triggers a one-shot pulse which resets the oscillator. It is possible to use the SYNC pin to generate oscillator duty cycles from approximately 20% up to the nominal duty cycle.

### Current Limit

Current limit for the MIC2571 is internally set with a resistor. It functions by modifying the oscillator duty cycle and frequency. When current exceeds 1.2A, the duty cycle is reduced (switch on-time is reduced, off-time is unaffected) and the corresponding frequency is increased. In this way less time is available for the inductor current to build up while maintaining the same discharge time. The onset of current limit is soft rather than abrupt but sufficient to protect the inductor and output switch from damage. Certain combinations of input voltage, output voltage and load current can cause the inductor to go into a continuous mode of operation. This is what happens when the inductor current can not fall to zero and occurs when:

$$\text{duty cycle} \leq \frac{V_{OUT} + V_{DIODE} - V_{IN}}{V_{OUT} + V_{DIODE} - V_{SAT}}$$

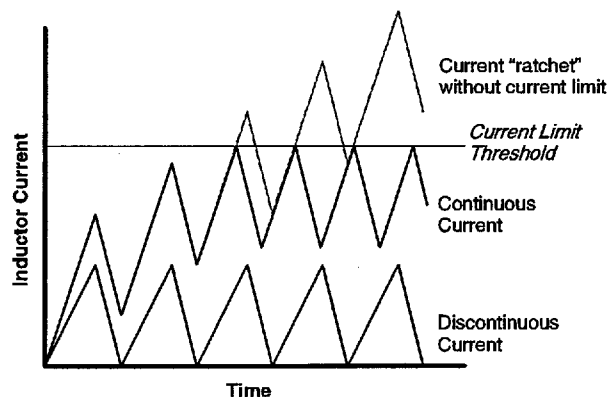
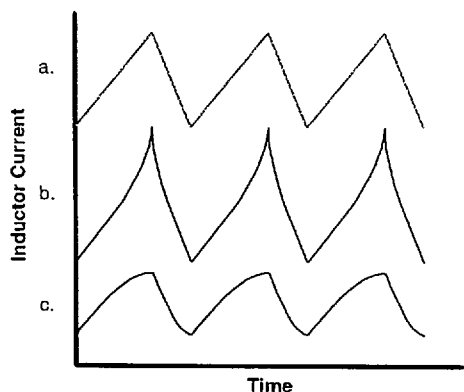

Figure 2. Current Limit Behavior

Figure 2 shows an example of inductor current in the continuous mode with its associated change in oscillator frequency and duty cycle. This situation is most likely to occur with relatively small inductor values, large input voltage variations and output voltages which are less than  $\sim 3 \times$  the input voltage. Selection of an inductor with a saturation threshold above 1.2A will insure that the system can withstand these conditions.

**Inductors, Capacitors and Diodes**

The importance of choosing correct inductors, capacitors and diodes can not be ignored. Poor choices for these components can cause problems as severe as circuit failure or as subtle as poorer than expected efficiency.



**Figure 3. Inductor Current: a. Normal, b. Saturating and c. Excessive ESR**

**Inductors**

Inductors must be selected such that they do not saturate under maximum current conditions. When an inductor saturates, its effective inductance drops rapidly and the current can suddenly jump to very high and destructive values.

Figure 3 compares inductors with currents that are correct and unacceptable due to core saturation. The inductors have the same nominal inductance but Figure 3b has a lower saturation threshold. Another consideration in the selection of inductors is the radiated energy. In general, toroids have the best radiation characteristics while bobbins have the worst. Some bobbins have caps or enclosures which significantly reduce stray radiation.

The last electrical characteristic of the inductor that must be considered is ESR (equivalent series resistance). Figure 3c shows the current waveform when ESR is excessive. The normal symptom of excessive ESR is reduced power transfer efficiency. Note that inductor ESR can be used to the designers advantage as reverse battery protection (current limit) for the case of relatively low output power one-cell designs. The potential for very large and destructive currents exists if a battery in a one-cell application is inserted backwards into the circuit. In some applications it is possible to limit the current to a nondestructive (but still battery draining) level by choosing a relatively high inductor ESR value which does not affect normal circuit performance.

**Capacitors**

It is important to select high-quality, low ESR, filter capacitors for the output of the regulator circuit. High ESR in the output capacitor causes excessive ripple due to the voltage drop across the ESR. A triangular current pulse with a peak of 500mA into a 200mΩ ESR can cause 100mV of ripple at the output due the capacitor only. Acceptable values of ESR are typically in the 50mΩ range. Inexpensive aluminum electrolytic capacitors usually are the worst choice while tantalum capacitors are typically better. Figure 4 demonstrates the effect of capacitor ESR on output ripple voltage.

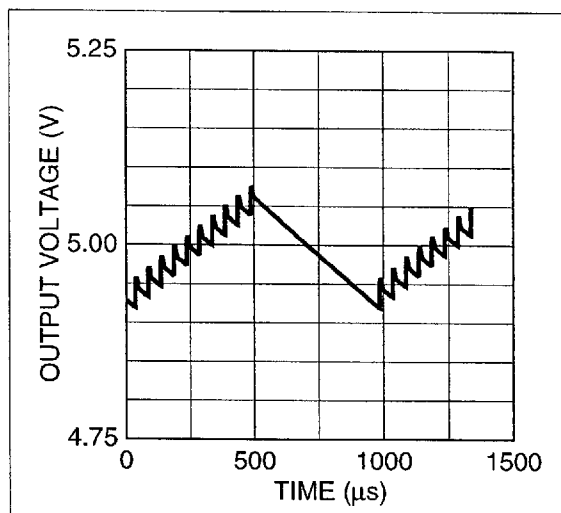

**Figure 4. Output Ripple**

**Output Diode**

Finally, the output diode must be selected to have adequate reverse breakdown voltage and low forward voltage at the application current. Schottky diodes typically meet these requirements.

Standard silicon diodes have forward voltages which are too large except in extremely low power applications. They can also be very slow, especially those suited to power rectification such as the 1N400x series, which affects efficiency.

**Inductor Behavior**

The inductor is an energy storage and transfer device. Its behavior (neglecting series resistance) is described by the following equation:

$$I = \frac{V}{L} \times t$$

where:

- V = inductor voltage (V)
- L = inductor value (H)
- t = time (s)
- I = inductor current (A)

If a voltage is applied across an inductor (initial current is zero) for a known time, the current flowing through the inductor is a linear ramp starting at zero, reaching a maximum value at the end of the period. When the output switch is on, the voltage across the inductor is:

$$V_1 = V_{IN} - V_{SAT}$$

When the output switch turns off, the voltage across the inductor changes sign and flies high in an attempt to maintain a constant current. The inductor voltage will eventually be clamped to a diode drop above  $V_{OUT}$ . Therefore, when the output switch is off, the voltage across the inductor is:

$$V_2 = V_{OUT} + V_{DIODE} - V_{IN}$$

For normal operation the inductor current is a triangular waveform which returns to zero current (discontinuous mode) at each cycle. At the threshold between continuous and discontinuous operation we can use the fact that  $I_1 = I_2$  to get:

$$V_1 \times t_1 = V_2 \times t_2$$

$$\frac{V_1}{V_2} = \frac{t_2}{t_1}$$

This relationship is useful for finding the desired oscillator duty cycle based on input and output voltages. Since input voltages typically vary widely over the life of the battery, care must be taken to consider the worst case voltage for each parameter. For example, the worst case for  $t_1$  is when  $V_{IN}$  is at its minimum value and the worst case for  $t_2$  is when  $V_{IN}$  is at its maximum value (assuming that  $V_{OUT}$ ,  $V_{DIODE}$  and  $V_{SAT}$  do not change much).

To select an inductor for a particular application, the worst case input and output conditions must be determined. Based on the worst case output current we can estimate efficiency and therefore the required input current. Remember that this is *power* conversion, so the worst case average input current will occur at maximum output current and minimum input voltage.

$$\text{Average } I_{IN(max)} = \frac{V_{OUT} \times I_{OUT(max)}}{V_{IN(min)} \times \text{Efficiency}}$$

Referring to Figure 1, it can be seen the peak input current will be twice the average input current. Rearranging the inductor equation to solve for L:

$$L = \frac{V}{I} \times t_1$$

$$L = \frac{V_{IN(min)}}{2 \times \text{Average } I_{IN(max)}} \times t_1$$

$$\text{where } t_1 = \frac{\text{duty cycle}}{f_{osc}}$$

To illustrate the use of these equations a design example will be given:

Assume:

MIC2571-1 (fixed oscillator)

$V_{OUT} = 5V$

$I_{OUT(max)} = 5mA$

$V_{IN(min)} = 1.0V$

efficiency = 75%.

$$\text{Average } I_{IN(max)} = \frac{5V \times 5mA}{1.0V \times 0.75} = 33.3mA$$

$$L = \frac{1.0V \times 0.7}{2 \times 33.3mA \times 20kHz}$$

$$L = 525\mu H$$

Use the next lowest standard value of inductor and verify that it does not saturate at a current below about 75mA ( $< 2 \times 33.3mA$ ).



# Application Examples

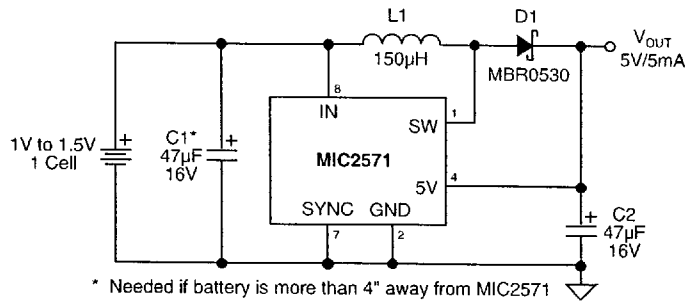

\* Needed if battery is more than 4" away from MIC2571

- U1 Micrel MIC2571-1BMM
- C1 Sprague 594D476X0016C2T Tantalum ESR = 0.11Ω
- C2 Sprague 594D476X0016C2T Tantalum ESR = 0.11Ω
- D1 Motorola MBR0530T1
- L1 Coilcraft DO1608C-154 DCR = 1.7Ω

**Example 1. 5V/5mA Regulator**

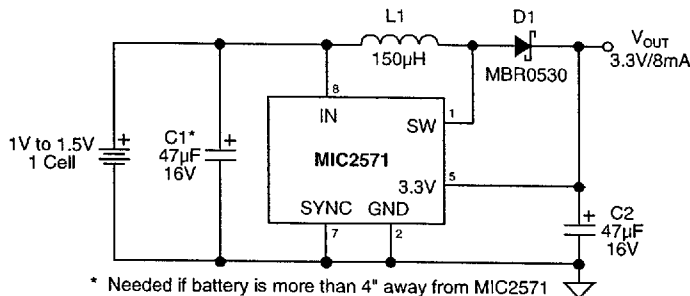

\* Needed if battery is more than 4" away from MIC2571

- U1 Micrel MIC2571-1BMM
- C1 Sprague 594D476X0016C2T Tantalum ESR = 0.11Ω
- C2 Sprague 594D476X0016C2T Tantalum ESR = 0.11Ω
- D1 Motorola MBR0530T1
- L1 Coilcraft DO1608C-154 DCR = 1.7Ω

**Example 2. 3.3V/8mA Regulator**

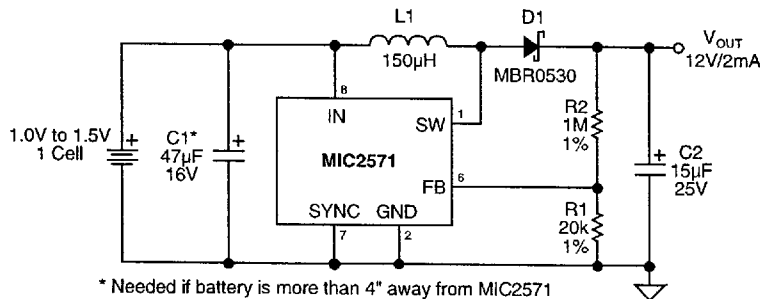

\* Needed if battery is more than 4" away from MIC2571

$$V_{OUT} = 0.22V \times (1 + R2/R1)$$

- U1 Micrel MIC2570-2BMM
- C1 Sprague 594D476X0016C2T Tantalum ESR = 0.11Ω
- C2 Sprague 594D156X0025C2T Tantalum ESR = 0.22Ω
- D1 Motorola MBRA0530T1
- L1 Coilcraft DO1608C-154 DCR = 1.7Ω

**Example 3. 12V/40mA Regulator**

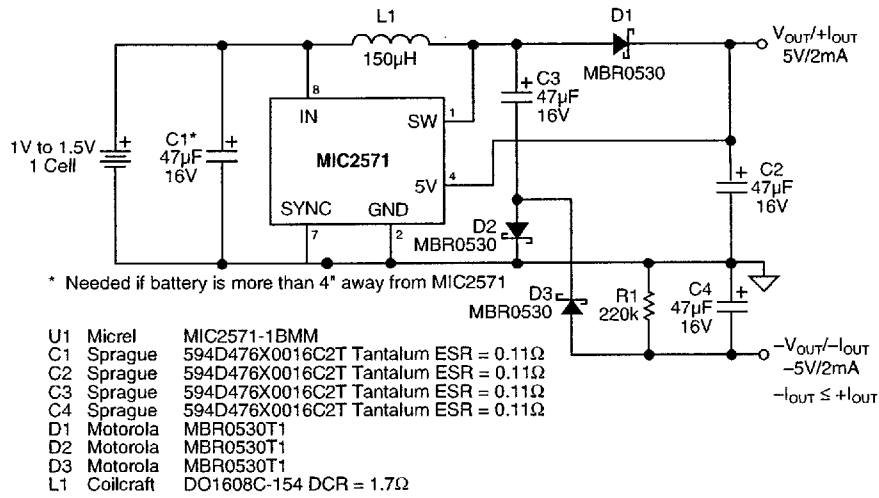

Example 4. ±5V/2mA Regulator

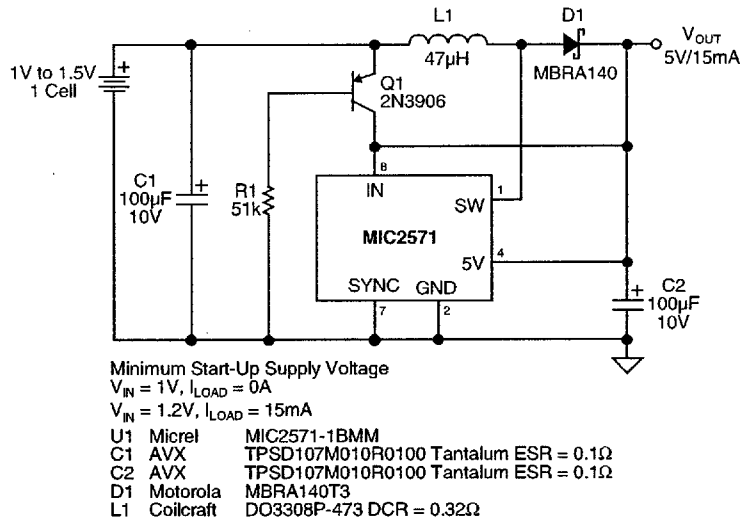

Example 5. 5V/15mA Regulator

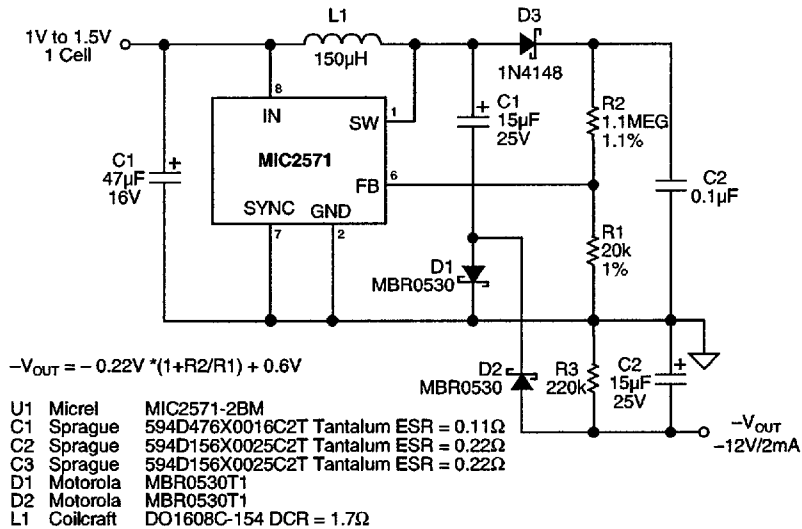

Example 6. -12V/2mA Regulator



### Suggested Manufacturers List

Inductors	Capacitors	Diodes
<p><i>Coilcraft</i> 1102 Silver Lake Rd. Cary, IL 60013 PH (708) 639-2361 FX (708) 639-1469</p>	<p><i>AVX Corp.</i> 801 17th Ave. South Myrtle Beach, SC 29577 PH (803) 448-9411 FX (803) 448-1943</p>	<p><i>General Instruments (GI)</i> 10 Melville Park Rd. Melville, NY 11747 PH (516) 847-3222 FX (516) 847-3150</p>
<p><i>Coiltronics</i> 6000 Park of Commerce Blvd. Boca Raton, FL 33487 PH (407) 241-7876 FX (407) 241-9339</p>	<p><i>Sanyo Video Components Corp.</i> 2001 Sanyo Ave. San Diego, CA 92173 PH (619) 661-6835 FX (619) 661-1055</p>	<p><i>International Rectifier Corp.</i> 233 Kansas St. El Segundo, CA 90245 PH (310) 322-3331 FX (310) 322-3332</p>
<p><i>Sumida</i> 637 E. Golf Road, Suite 209 Arlington Heights, IL PH (708) 956-0666 FX (708) 956-0702</p>	<p><i>Sprague Electric</i> Lower Main Street 60005Sanford, ME 04073 PH (207) 324-4140</p>	<p><i>Motorola Inc.</i> 3102 North 56th St. MS 56-126 Phoenix, AZ 85018 PH (602) 244-3576 FX (602) 244-4015</p>

### Evaluation Board Layout

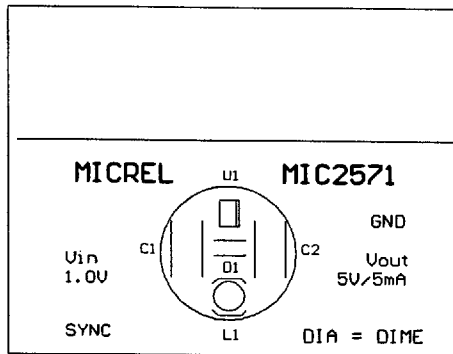
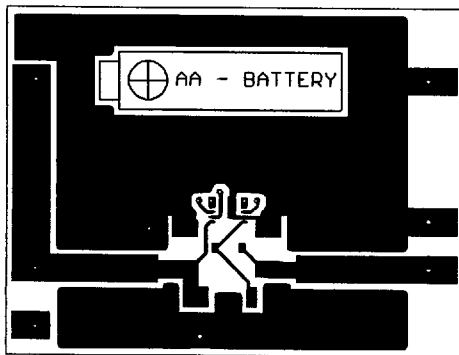

Component Side and Silk Screen (Not Actual Size)

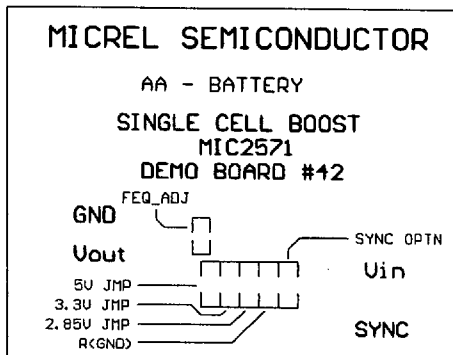
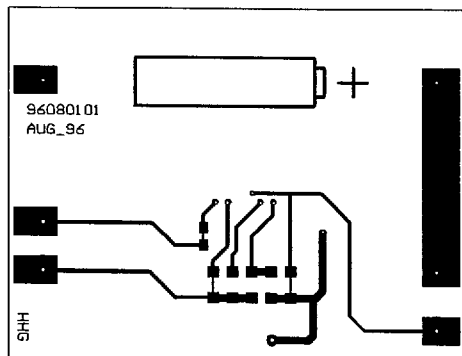

Solder Side and Silk Screen (Not Actual Size)

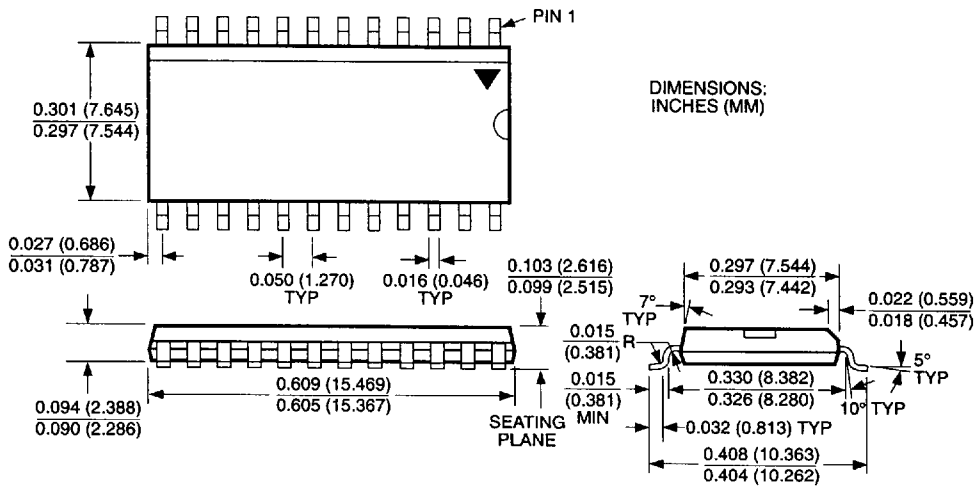

24-Pin Wide SOIC (WM)

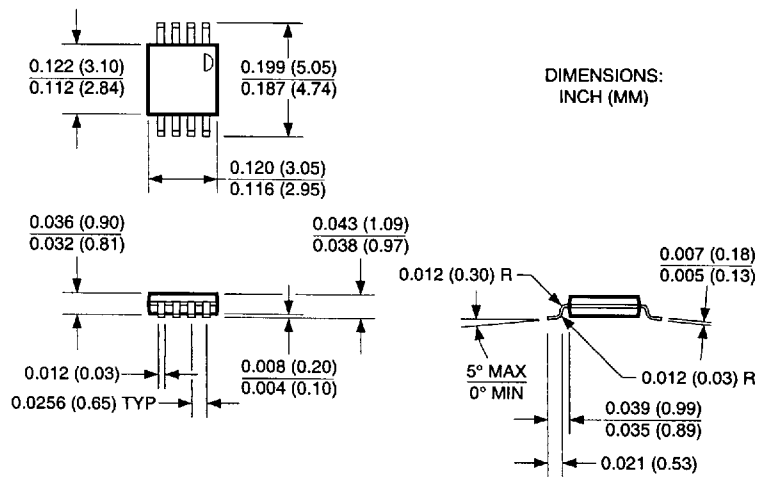

8-Lead MSOP (MM)