

TOSHIBA PHOTOCOUPLER GaAs IRED & PHOTO-TRIAC

TLP3020, TLP3021, TLP3022, TLP3023

Unit in mm

OFFICE MACHINE

HOUSEHOLD USE EQUIPMENT

TRIAC DRIVER

SOLID STATE RELAY

The TOSHIBA TLP3020, TLP3021, TLP3022 and TLP3023 consist of a photo-triac optically coupled to a gallium arsenide infrared emitting diode in a six lead plastic DIP package.

- Peak Off-State Voltage : 400V (Min.)
- Trigger LED Current : 30mA (Max.) (TLP3020)
15mA (Max.) (TLP3021)
10mA (Max.) (TLP3022)
5mA (Max.) (TLP3023)
- On-State Current : 100mA (Max.)
- UL Recognized : UL1577, File No. E67349
Isolation Voltage : 5000Vrms (Min.)
- Option (D4) type
VDE Approved : DIN VDE0884 / 08.87,
Certificate No. 68329

Maximum Operating Insulation Voltage : 630V_{PK}
Highest Permissible Over Voltage : 6000V_{PK}

(Note) When a VDE0884 approved type is needed, please designate the "Option (D4)"

- | | | |
|------------------------|----------------------|-------------------|
| | 7.62mm pich | 10.16mm pich |
| | <u>standard type</u> | <u>(LF2) type</u> |
| ● Creepage Distance : | 7.0mm (Min.) | 8.0mm (Min.) |
| Clearance : | 7.0mm (Min.) | 8.0mm (Min.) |
| Insulation Thickness : | 0.5mm (Min.) | 0.5mm (Min.) |

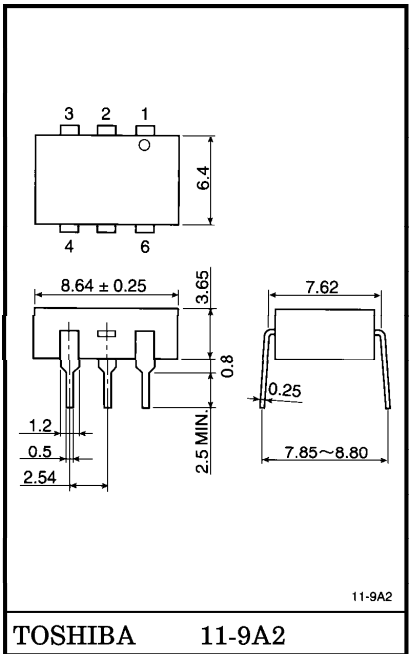

Weight : 0.44g

PIN CONFIGURATION (TOP VIEW)

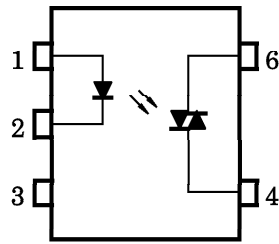

- 1 : ANODE
- 2 : CATHODE
- 3 : NC
- 4 : TERMINAL 1
- 6 : TERMINAL 2

961001EBC2

● TOSHIBA is continually working to improve the quality and the reliability of its products. Nevertheless, semiconductor devices in general can malfunction or fail due to their inherent electrical sensitivity and vulnerability to physical stress. It is the responsibility of the buyer, when utilizing TOSHIBA products, to observe standards of safety, and to avoid situations in which a malfunction or failure of a TOSHIBA product could cause loss of human life, bodily injury or damage to property. In developing your designs, please ensure that TOSHIBA products are used within specified operating ranges as set forth in the most recent products specifications. Also, please keep in mind the precautions and conditions set forth in the TOSHIBA Semiconductor Reliability Handbook.

● Gallium arsenide (GaAs) is a substance used in the products described in this document. GaAs dust and fumes are toxic. Do not break, cut or pulverize the product, or use chemicals to dissolve them. When disposing of the products, follow the appropriate regulations. Do not dispose of the products with other industrial waste or with domestic garbage.

● The products described in this document are subject to foreign exchange and foreign trade control laws.

● The information contained herein is presented only as a guide for the applications of our products. No responsibility is assumed by TOSHIBA CORPORATION for any infringements of intellectual property or other rights of the third parties which may result from its use. No license is granted by implication or otherwise under any intellectual property or other rights of TOSHIBA CORPORATION or others.

● The information contained herein is subject to change without notice.

MAXIMUM RATINGS (Ta = 25°C)

CHARACTERISTIC		SYMBOL	RATING	UNIT
LED	Forward Current	I_F	50	mA
	Forward Current Derating (Ta ≥ 53°C)	$\Delta I_F / ^\circ C$	-0.7	mA / °C
	Peak Forward Current (100µs pulse, 100pps)	I_{FP}	1	A
	Power Dissipation	P_D	100	mW
	Power Dissipation Derating (Ta ≥ 25°C)	$\Delta P_D / ^\circ C$	-1.0	mW / °C
	Reverse Voltage	V_R	5	V
	Junction Temperature	T_j	125	°C
DETECTOR	Off-State Output Terminal Voltage	V_{DRM}	400	V
	On-State RMS Current	Ta = 25°C	100	mA
		Ta = 70°C	50	
	On-State Current Derating (Ta ≥ 25°C)	$\Delta I_T / ^\circ C$	-1.1	mA / °C
	Peak On-State Current (100µs pulse, 120pps)	I_{TP}	2	A
	Peak Nonrepetitive Surge Current (PW = 10ms, DC = 10%)	I_{TSM}	1.2	A
	Power Dissipation	P_D	300	mW
	Power Dissipation Derating (Ta ≥ 25°C)	$\Delta P_D / ^\circ C$	-4.0	mW / °C
Junction Temperature	T_j	115	°C	
Storage Temperature Range	T_{stg}	-55~150	°C	
Operating Temperature Range	T_{opr}	-40~100	°C	
Lead Soldering Temperature (10s)	T_{sol}	260	°C	
Total Package Power Dissipation	P_T	330	mW	
Total Package Power Dissipation Derating (Ta ≥ 25°C)	$\Delta P_T / ^\circ C$	-4.4	mW / °C	
Isolation Voltage (AC, 1 min., R.H. ≤ 60%) (Note 1)	BV_S	5000	Vrms	

(Note 1) Device considered a two terminal device : Pins 1, 2 and 3 shorted together and pins 4 and 6 shorted together.

RECOMMENDED OPERATING CONDITIONS

CHARACTERISTIC	SYMBOL	MIN.	TYP.	MAX.	UNIT
Supply Voltage	V_{AC}	—	—	120	Vac
Forward Current	I_F^*	15	20	25	mA
Peak On-State Current	I_{TP}	—	—	1	A
Operating Temperature	T_{opr}	-25	—	85	°C

* In the case of TLP3022

INDIVIDUAL ELECTRICAL CHARACTERISTICS (Ta = 25°C)

CHARACTERISTIC		SYMBOL	TEST CONDITION	MIN.	TYP.	MAX.	UNIT
LED	Forward Voltage	V_F	$I_F = 10\text{mA}$	1.0	1.15	1.3	V
	Reverse Current	I_R	$V_R = 5\text{V}$	—	—	10	μA
	Capacitance	C_T	$V = 0, f = 1\text{MHz}$	—	10	—	pF
DETECTOR	Peak Off-State Current	I_{DRM}	$V_{DRM} = 400\text{V}$	—	10	100	nA
	Peak On-State Voltage	V_{TM}	$I_{TM} = 100\text{mA}$	—	1.7	3.0	V
	Holding Current	I_H	—	—	0.6	—	mA
	Critical Rate of Rise of Off-State Voltage	dv/dt	$V_{in} = 120\text{Vrms}, T_a = 85^\circ\text{C}$ (Fig.1)	200	500	—	$\text{V}/\mu\text{s}$
	Critical Rate of Rise of Commutating Voltage	$dv/dt(c)$	$V_{in} = 30\text{Vrms}, I_F = 15\text{mA}$ (Fig.1)	—	0.2	—	$\text{V}/\mu\text{s}$

COUPLED ELECTRICAL CHARACTERISTICS (Ta = 25°C)

CHARACTERISTIC		SYMBOL	TEST CONDITION	MIN.	TYP.	MAX.	UNIT
Trigger LED Current	TLP3020	I_{FT}	$V_T = 3\text{V}$	—	—	30	mA
	TLP3021			—	—	15	
	TLP3022			—	5	10	
	TLP3023			—	—	5	
Capacitance Input to Output	C_S		$V_S = 0, f = 1\text{MHz}$	—	0.8	—	pF
Isolation Resistance	R_S		$V_S = 500\text{V} (\text{R.H.} \leq 60\%)$	5×10^{10}	10^{14}	—	Ω
Isolation Voltage	B_{VS}		AC, 1 minute	—	—	—	V_{rms}
			AC, 1 second (in oil)	—	10000	—	V_{dc}
			DC, 1 minute (in oil)	—	10000	—	

Fig.1 dv/dt TEST CIRCUIT

