

CMOS Photodetector with Logic Output

Description

TEKS6400 is a high sensitive CMOS Photo Schmitt Trigger in a sideview plastic package with spherical lens. The integrated Daylight filter is matched to IR emitters, $\lambda = 950 \text{ nm}$.

TSKS5400 is the compatible IR emitter for design of optical sensors (e.g. transmissive or reflective).

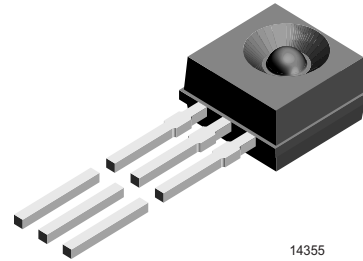

Features

- Very high photo sensitivity
- Supply voltage range 2.5 V to 5.5 V
- Low current consumption (45 μA)
- Miniature plastic package with side view lens
- Angle of half sensitivity $\varphi = \pm 30^\circ$
- TTL and CMOS compatible
- Open collector output
- Output signal level: (active "low")
- Package compatible to TSKS5400
- Lead-free device

Parts Table

Part	Type differentiation	Ordering code
TEKS6400-FSZ	1.27 mm Pin distance (lead to lead), height of taping 27 mm	TEKS6400-FSZ

Absolute Maximum Ratings

$T_{\text{amb}} = 25^\circ\text{C}$, unless otherwise specified

Parameter	Test condition	Symbol	Value	Unit
Supply voltage range		V_{S1}/V_{S2}	- 0.3 to + 5.5	V
Output current		I_O	20	mA
Power dissipation		P_V	50	mW
Junction temperature		T_J	100	$^\circ\text{C}$
Operating temperature range		T_{amb}	- 40 to + 85	$^\circ\text{C}$
Storage temperature range		T_{stg}	- 40 to + 100	$^\circ\text{C}$
Soldering temperature	$t \leq 5 \text{ s}$, 2 mm from body	T_{sd}	260	$^\circ\text{C}$

Handling Precautions:

Caution:

ESD (electrostatic discharge) sensitive device. Permanent damage may occur on unconnected devices subject to high energy electrostatic fields.

Basic Characteristics

$T_{amb} = 25\text{ }^{\circ}\text{C}$, unless otherwise specified

Parameter	Test condition	Symbol	Min	Typ.	Max	Unit
Supply voltage		V_{S1}/V_{S2}	2.5		5.5	V
Supply current	$V_{S1} = 5.5\text{ V}$	I_{S1}		45	100	μA
Irradiance for threshold "On"	$\lambda = 950\text{ nm}, V_{S1} = 5\text{ V}$	$E_{e\text{on}}$	25	50	100	$\mu\text{W}/\text{cm}^2$
Hysteresis	$V_{S1} = 5\text{ V}$	$E_{e\text{off}}/E_{e\text{on}}$		80		%
Angle of half sensitivity		ϕ		± 30		$^{\circ}$
Wavelength of peak sensitivity		λ_p		920		nm
Range of Spectral Bandwidth		$\lambda_{0.5}$		825 to 950		nm
Output voltage	$R_L = 270\ \Omega, V_{S1} = V_{S2} = 5.5\text{ V}, E_e \geq E_{e\text{on}}, \lambda = 950\text{ nm}$	V_{OL}		0.2	0.4	V
High level output current	$V_{S1} = V_{S2} = 5.5\text{ V}, I_F = 0$	I_{OH}			1	μA

Switching Characteristics

$T_{amb} = 25\text{ }^{\circ}\text{C}$, unless otherwise specified

Parameter	Test condition	Symbol	Typ.	Unit
Propagation delay time ON	$V_{S1} = V_{S2} = 5\text{ V}, R_L = 270\ \Omega, E_e = 3 * E_{e\text{on}}, \lambda = 950\text{ nm}$	t_{phl}	1.5	μs
Propagation delay time OFF	$V_{S1} = V_{S2} = 5\text{ V}, R_L = 270\ \Omega, E_e = 3 * E_{e\text{on}}, \lambda = 950\text{ nm}$	t_{plh}	3.0	μs

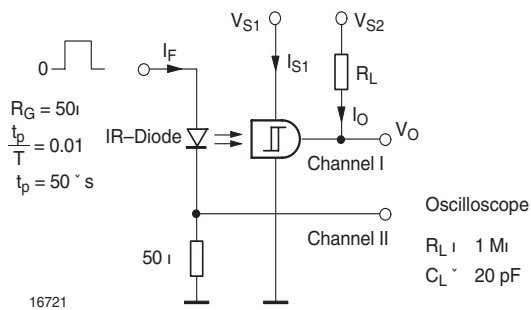

Fig. 1 Test Circuit

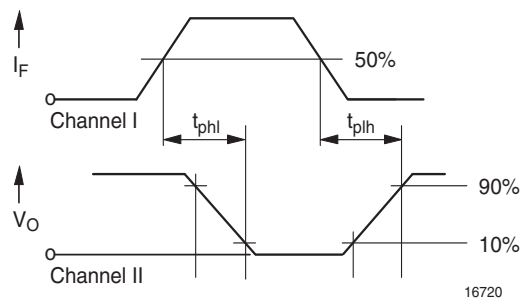

Fig. 2 Pulse diagram

Typical Characteristics ($T_{amb} = 25\text{ }^{\circ}\text{C}$ unless otherwise specified)

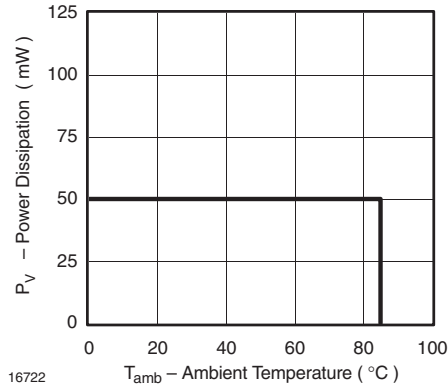

Fig. 3 Power Dissipation vs. Ambient Temperature

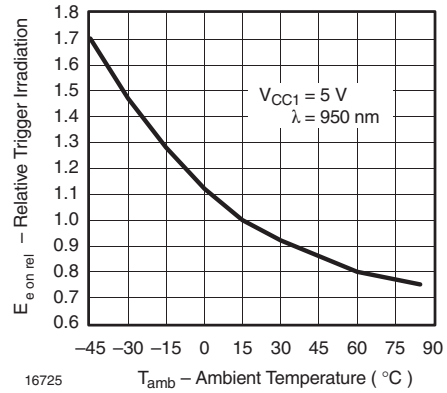

Fig. 6 Rel. Trigger Irradiation vs. Ambient Temperature

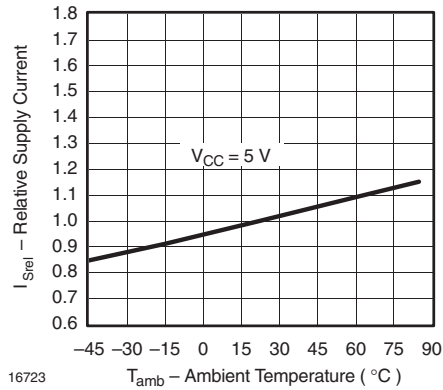

Fig. 4 Rel. Supply Current vs. Ambient Temperature

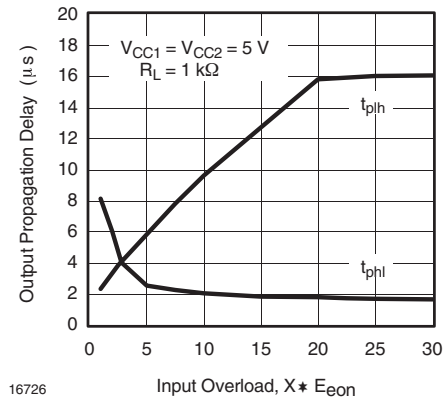

Fig. 7 Propagation Delay vs. Input Overload

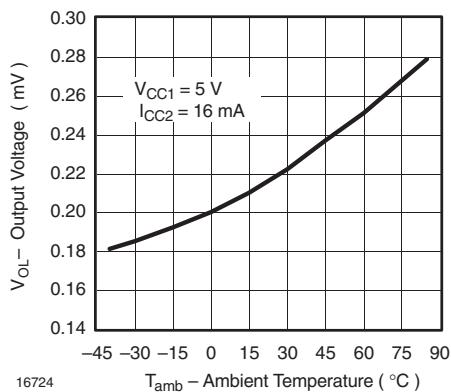

Fig. 5 Output Voltage vs. Ambient Temperature

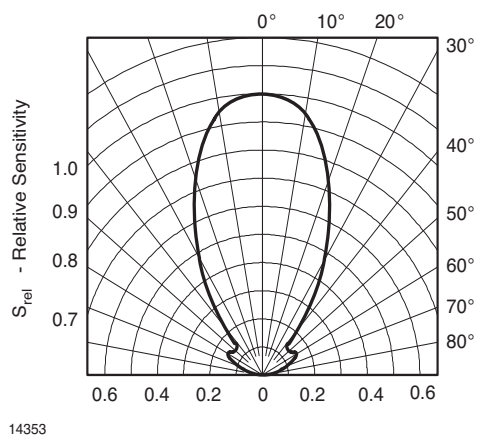
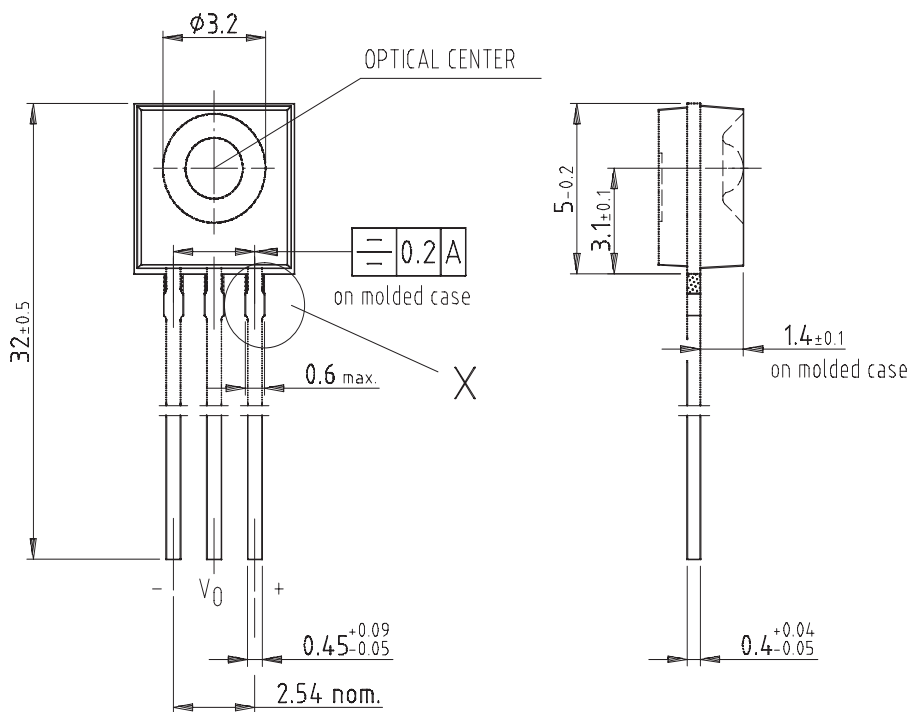
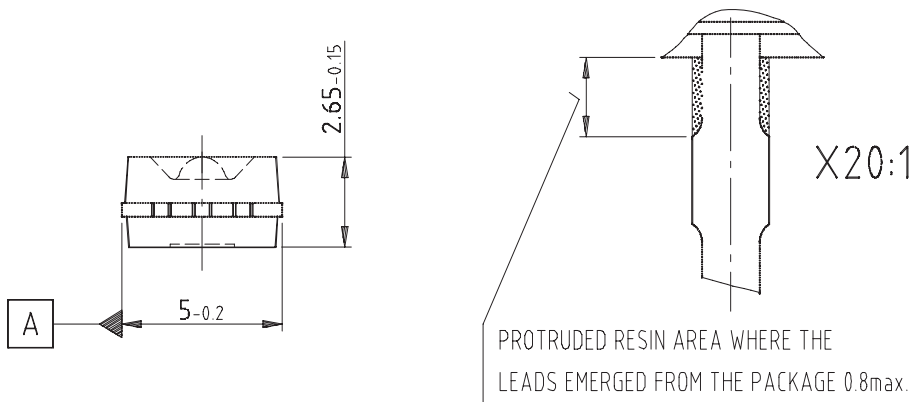

Fig. 8 Relative Radiant Sensitivity vs. Angular Displacement

Package Dimensions in mm



technical drawings
according to DIN
specifications

Drawing-No.: 6.544-5309.51-4

Issue: 8; 16.05.02

14346

Tape and Ammopack Standards

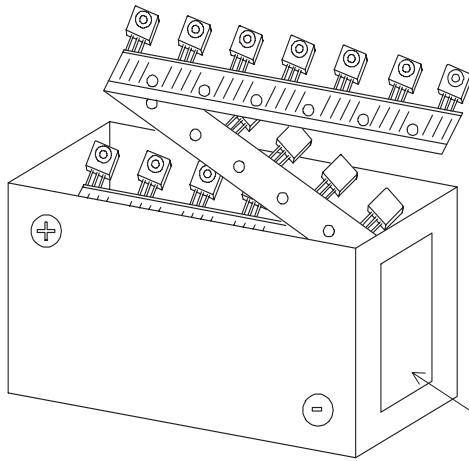

Kennzeichnung: Barcode-Etikett siehe 5.6.4
 Labeling: Barcode-label see 5.6.4

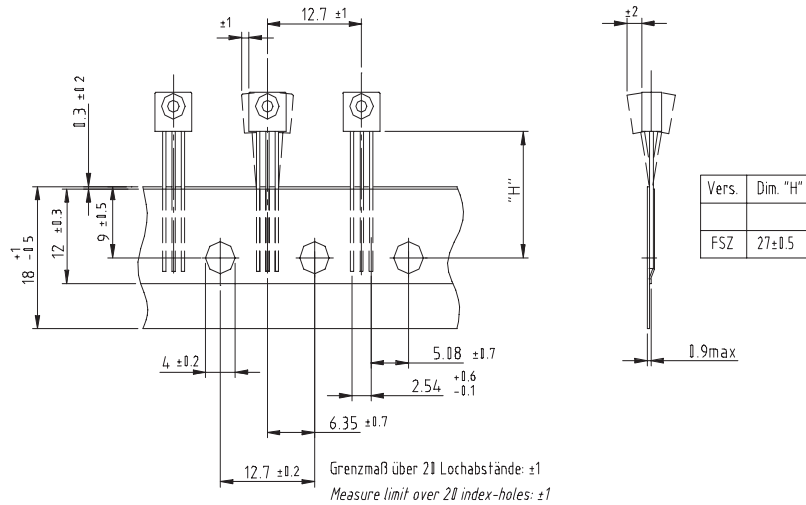

16717

Ozone Depleting Substances Policy Statement

It is the policy of **Vishay Semiconductor GmbH** to

1. Meet all present and future national and international statutory requirements.
2. Regularly and continuously improve the performance of our products, processes, distribution and operating systems with respect to their impact on the health and safety of our employees and the public, as well as their impact on the environment.

It is particular concern to control or eliminate releases of those substances into the atmosphere which are known as ozone depleting substances (ODSs).

The Montreal Protocol (1987) and its London Amendments (1990) intend to severely restrict the use of ODSs and forbid their use within the next ten years. Various national and international initiatives are pressing for an earlier ban on these substances.

Vishay Semiconductor GmbH has been able to use its policy of continuous improvements to eliminate the use of ODSs listed in the following documents.

1. Annex A, B and list of transitional substances of the Montreal Protocol and the London Amendments respectively
2. Class I and II ozone depleting substances in the Clean Air Act Amendments of 1990 by the Environmental Protection Agency (EPA) in the USA
3. Council Decision 88/540/EEC and 91/690/EEC Annex A, B and C (transitional substances) respectively.

Vishay Semiconductor GmbH can certify that our semiconductors are not manufactured with ozone depleting substances and do not contain such substances.

**We reserve the right to make changes to improve technical design
and may do so without further notice.**

Parameters can vary in different applications. All operating parameters must be validated for each customer application by the customer. Should the buyer use Vishay Semiconductors products for any unintended or unauthorized application, the buyer shall indemnify Vishay Semiconductors against all claims, costs, damages, and expenses, arising out of, directly or indirectly, any claim of personal damage, injury or death associated with such unintended or unauthorized use.

Vishay Semiconductor GmbH, P.O.B. 3535, D-74025 Heilbronn, Germany
Telephone: 49 (0)7131 67 2831, Fax number: 49 (0)7131 67 2423