

SONET OC-48 Transceiver

Features

- SONET OC-48 operation
- Full Bellcore and ITU jitter compliance
- 2.488-GBaud serial signaling rate
- Multiple selectable loopback/loop-through modes
- Single 155.52-MHz reference clock
- Transmit FIFO for flexible data interface clocking
- 16-bit parallel-to-serial conversion in transmit path
- Serial to 16-bit parallel conversion in receive path
- Synchronous HSTL parallel interface
 - Drives Low-Z transmission lines
 - No resistors for short (70-mm) interconnect
 - LVPECL compliant
- Internal transmit and receive PLLs
- Differential CML serial input
 - Internal termination and DC-restoration
- Differential CML serial output
 - Source matched for 50Ω transmission lines
- Direct interface to standard fiber-optic modules
- Single +3.3V supply (1.3W typ.)
- 120-pin 14 mm x 14 mm TQFP
- Standby power-saving mode for inactive loops
- 0.25μ BiCMOS technology

Functional Description

The CY7B9532V SONET OC-48 Transceiver is a communications building block for high-speed SONET data communications. It provides complete parallel-to-serial and serial-to-parallel conversion in a single chip, optimized for full SONET compliance.

Transmit Path

New data is accepted at the 16-bit parallel transmit interface at rate of 155.52 MHz. This data is passed to a small integrated

FIFO to allow flexible transfer of data between the SONET processor and the transmit serializer. As each 16-bit word is read from the transmit FIFO, it is serialized and sent out the high-speed differential line driver at a rate of 2.488 Gbits/second.

Receive Path

As serial data is received at the differential line receiver, it is passed to a clock and data recovery (CDR) phase-locked loop (PLL) which extracts a precision low-jitter clock from the transitions in the data stream. This bit-rate clock is then used to sample the data stream and receive the data. Every 16 bit-times, a new word is presented at the receive parallel interface along with a clock.

Parallel Interface

The parallel I/O interface supports high-speed bus communications using HSTL signaling levels to minimize both power consumption and board landscape. The HSTL outputs are capable of driving unterminated transmission lines of greater than 70 mm, and terminated 50Ω transmission lines of more than twice that length.

The CY7B9532V Transceiver's parallel HSTL I/O can also be configured to operate at LVPECL signaling levels. This can all be done externally by changing V_{DDQ} , V_{REF} and creating a simple circuit at the termination of the receiver's parallel I/O interface.

Clocking

The source clock for the transmit data path is selectable from either the recovered clock or an external BITS (Building Integrated Timing Source) reference clock. The low jitter of the CDR PLL allows loop-timed operation of the transmit data path while still meeting all Bellcore and ITU jitter requirements.

Multiple loopback and loop-through modes are available for both diagnostic and normal operation. For systems containing redundant SONET rings that are maintained in standby, the CY7B9532V may also be dynamically powered down to conserve system power.

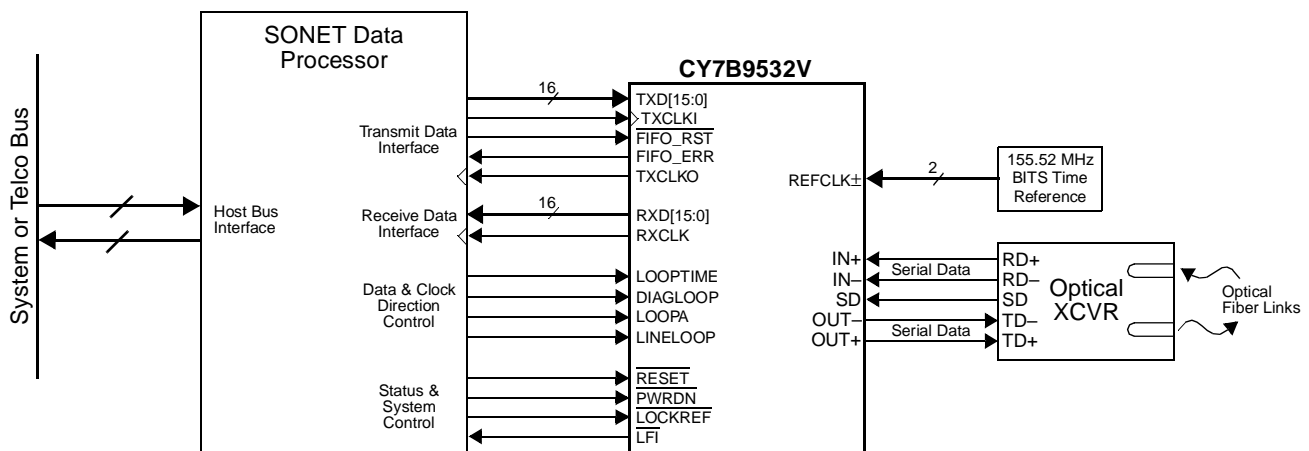
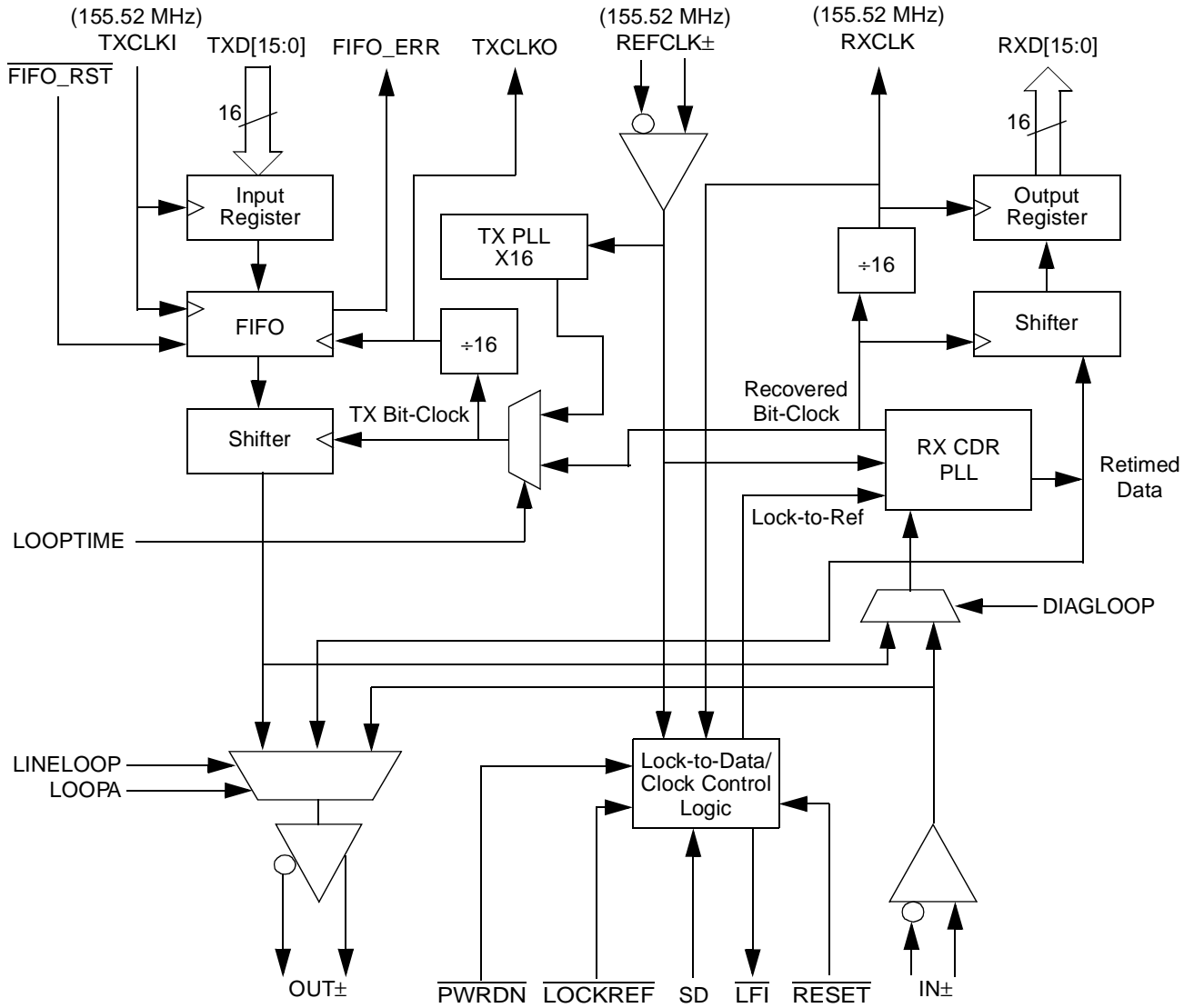
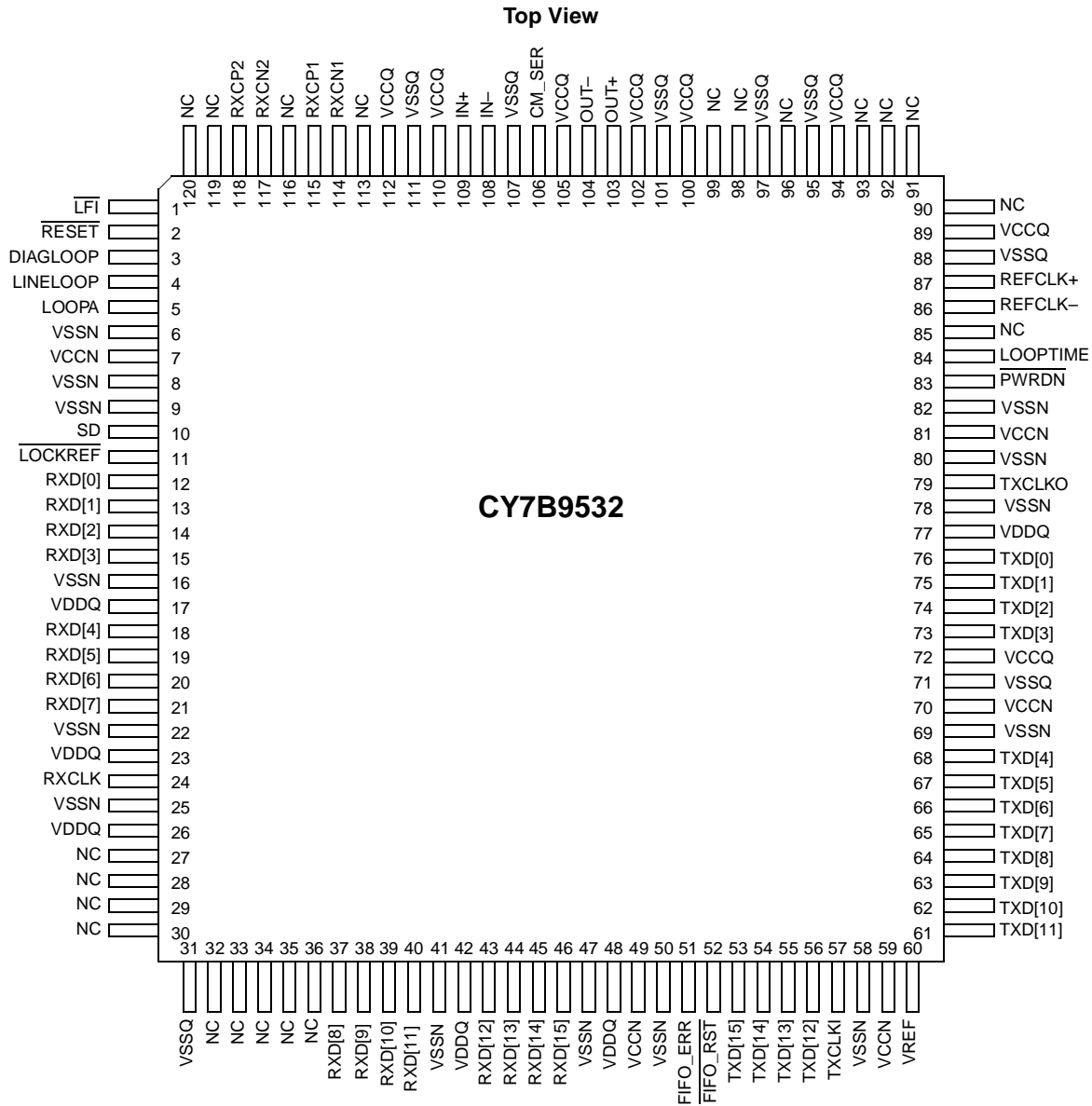

Figure 1. CY7B9532V System Connections

CY7B9532V Logic Block Diagram



Pin Configuration

Maximum Ratings

(Above which the useful life may be impaired. For user guidelines, not tested.)

Storage Temperature -65°C to +150°C

Ambient Temperature with Power Applied -55°C to +125°C

V_{CC} Supply Voltage to Ground Potential -0.5V to +4.2V

V_{DDQ} Supply Voltage to Ground Potential -0.5V to +3.0V

DC Voltage Applied to HSTL Outputs in High-Z State -0.5V to V_{DDQ}+0.5V

DC Voltage Applied to Other Outputs in High-Z State -0.5V to V_{CC}+0.5V

Output Current into LVTTTL Outputs (LOW) 30 mA

DC Input Voltage -0.5V to V_{CC}+0.5V

Static Discharge Voltage > 2001 V (per MIL-STD-883, Method 3015)

Latch-Up Current > 200 mA

Operating Range

Range	Ambient Temperature	V _{DDQ}	V _{CC}
Commercial	0°C to +70°C	1.6V to 1.4V	3.3V ± 10%
Industrial	-40°C to +85°C	1.6V to 1.4V	3.3V ± 5%

Pin Descriptions

CY7B9532V OC-48 SONET Transceiver

Name	I/O Characteristics	Signal Description
Transmit Path Signals		
TXDA[15:0]	HSTL inputs, sampled by TXCLKI↑	Parallel Transmit Data Inputs. A 16-bit word, sampled by TXCLKI↑. TXD[15] is the most significant bit (the first bit transmitted).
TXCLKI	HSTL Clock input	Parallel Transmit Data Input Clock
TXCLKO	HSTL Clock output	Transmit Clock Output. Divide by 16 of the selected transmit bit-rate clock
Receive Path Signals		
RXD[15:0]	HSTL output, synchronous	Parallel Receive Data Output. These outputs change following RXCLKO↓. RXD[15] is the most significant bit of the output word, and is received first on the serial interface.
RXCLK	HSTL Clock output	Receive Clock Output. Divide by 16 of the bit-rate clock extracted from the received serial stream.
Device Control and Status Signals		
REFCLK±	Differential LVPECL input	Reference Clock. This clock input is used as the timing reference for the transmit and receive PLLs. A derivative of this input clock may also be used to clock the transmit parallel interface.
LFI	LVTTTL output	Line Fault Indicator. When LOW, this signal indicates that the selected receive data stream has been detected as invalid by either a LOW input on SD, or by the receive VCO being operated outside its specified limits.
RESET	LVTTTL input	Reset for all logic functions except the transmit FIFO.
LOCKREF	LVTTTL input	Receive PLL Lock to Reference. When LOW, the receive PLL locks to REFCLK instead of the received serial data stream.
SD	LVTTTL input	Signal Detect. When LOW, the receive PLL locks to REFCLK instead of the received serial data stream.
FIFO_ERR	LVTTTL output	Transmit FIFO Error. When HIGH the transmit FIFO has either under or overflowed. The FIFO must be reset to clear the error indication.
FIFO_RST	LVTTTL input	Transmit FIFO Reset. When LOW, the in and out pointers of the transmit FIFO are set to maximum separation.
PWRDN	LVTTTL input	Device Power Down. When LOW, the logic and drivers are all disabled and placed into a standby condition where only minimal power is dissipated.
Receive Path Signals		
CM_SER	Analog	Common Mode Termination. Capacitor shunt to V_{SS} for common mode noise.
RXCN1	Analog	Receive Loop Filter Capacitor (Negative)
RXCN2	Analog	Receive Loop Filter Capacitor (Negative)
RXCP1	Analog	Receive Loop Filter Capacitor (Positive)
RXCP2	Analog	Receive Loop Filter Capacitor (Positive)
V _{REF}	HSTL Analog Reference	$V_{DDQ}/2$.
Loop Control Signals		
DIAGLOOP	LVTTTL input	Diagnostic Loopback Control. When HIGH, transmit data is routed through the receive clock and data recovery and presented at the RXD[15:0] outputs. When LOW, received serial data is routed through the receive clock and data recovery and presented at the RXD[15:0] outputs.
LINELOOP	LVTTTL input	Line Loopback Control. When HIGH, received serial data is looped back from receive to transmit after being relocked by a recovered clock. When LINELOOP is LOW, the data passed to the OUT± line driver is controlled by LOOPA. When both LINELOOP and LOOPA are LOW, the data passed to the OUT± line driver is generated in the transmit shifter.

Pin Descriptions (continued)

CY7B9532V OC-48 SONET Transceiver

Name	I/O Characteristics	Signal Description
LOOPA	LVTTTL input	Analog Line Loopback. When LINELOOP is LOW and LOOPA is HIGH, received serial data is looped back from receive input buffer to transmit output buffer, but is not routed through the clock and data recovery PLL. When LOOPA is LOW, the data passed to the OUT± line driver is controlled by LINELOOP.
LOOPTIME	LVTTTL input	Loop Time Mode. When HIGH, the extracted receive bit-clock replaces transmit bit-clock. When LOW, the REFCLK input is multiplied by 16 to generate the transmit bit clock.
Serial I/O		
OUT±	Differential CML output	Differential Serial Data Output. This differential CML output (+3.3V referenced) is capable of driving terminated 50Ω transmission lines or commercial fiber-optic transmitter modules.
IN±	Differential CML input	Differential Serial Data Input. This differential input accept the serial data stream for deserialization and clock extraction.
Power		
V _{CCN}	Power	+3.3V Supply (for digital and low-speed I/O functions)
V _{SSN}	Ground	Signal and Power Ground (for digital and low-speed I/O functions)
V _{CCQ}		+3.3V Quiet Power (for analog functions)
V _{SSQ}		Quiet Ground (for analog functions)
V _{DDQ}		+1.5V Supply for HSTL Outputs

CY7B9532 Operation

The CY7B9532 is a highly configurable device designed to support reliable transfer of large quantities of data, using high-speed serial links. It performs necessary clock and data recovery, clock generation, serial-to-parallel conversion, and parallel-to-serial conversion. CY7B9532 also provides various loop-back functions.

CY7B9532 Transmit Data Path
Operating Modes

The transmit path of the CY7B9532 supports 16-bit-wide data paths.

Phase-Align Buffer

Data from the input register is passed to a phase-align buffer (FIFO). This buffer is used to absorb clock phase differences between the transmit input clock and the internal character clock.

Initialization of the phase-align buffer takes place when the FIFO_RST input is asserted LOW. When FIFO_RST is returned HIGH, the present input clock phase relative to TXCLKI is set. Once set, the input clock is allowed to skew in time up to half a character period in either direction relative to REFCLK; i.e., ±180°. This time shift allows the delay path of the character clock (relative to REFCLK) to change due to operating voltage and temperature, while not effecting the design operation. FIFO_RST is an asynchronous input. FIFO_ERR is the transmit FIFO Error indicator. When HIGH, the transmit FIFO has either under or overflowed. The FIFO can be externally reset to clear the error indication or if no action is taken the internal clearing mechanism will clear the FIFO in 9 clock cycles. When the FIFO is being reset, the output data is 1010.

Transmit PLL Clock Multiplier

The Transmit PLL Clock Multiplier accepts a 155.52-MHz external clock at the REFCLK input, and multiplies that clock by 16 to generate a bit-rate clock for use by the transmit shifter. The operating serial signaling rate and allowable range of REFCLK frequencies is listed in *Table 7*. The REFCLK± input is a standard PECL input.

Serializer

The parallel data from the phase-align buffer is passed to the Serializer which converts the parallel data to serial data using the bit-rate clock generated by the Transmit PLL clock multiplier. TXD[15] is the most significant bit of the output word, and is transmitted first on the serial interface.

Serial Output Driver

The serial interface Output Driver makes use of high-performance differential CML (Current Mode Logic) to provide a source-matched driver for the transmission lines. This driver receives its data from the Transmit Shifters or the receive loop-back data. The outputs have signal swings equivalent to that of standard PECL drivers, and are capable of driving AC-coupled optical modules or transmission lines.

CY7B9532 Receive Data Path
Serial Line Receivers

A differential line receiver, IN± is available for accepting the input serial data stream. The serial line receiver inputs can accommodate high wire interconnect and filtering losses or transmission line attenuation ($V_{DIF} \geq 125$ mV, or 250 mV peak-to-peak differential) and can be AC-coupled to +3.3V or +5V powered fiber-optic interface modules. The common-mode tol-

erance of these line receivers accommodates a wide range of signal termination voltages.

Lock to Data Control

Line Receiver routed to the clock and data recovery PLL is monitored for

- status of signal detect (SD) pin
- status of LOCKREF pin
- received data stream outside normal frequency range (± 200 ppm)

This status is presented on the $\overline{\text{LFI}}$ (Link Fault Indicator) output, which changes asynchronously in the cases when SD or LOCKREF goes from HIGH to LOW. Otherwise, it changes synchronous to the REFCLK.

Clock/Data Recovery

The extraction of a bit-rate clock and recovery of data bits from received serial stream is performed by a Clock/Data Recovery (CDR) block. The clock extraction function is performed by high-performance embedded phase-locked loop (PLL) that tracks the frequency of the incoming bit stream and aligns the phase of the internal bit-rate clock to the transitions in the selected serial data stream.

CDR accepts a character-rate (bit-rate $\div 16$) reference clock on the REFCLK input. This REFCLK input is used to ensure that the VCO (within the CDR) is operating at the correct frequency (rather than some harmonic of the bit-rate), to improve PLL acquisition time, and to limit unlocked frequency excursions of the CDR VCO when no data is present at the serial inputs.

Regardless of the type of signal present, the CDR will attempt to recover a data stream from it. If the frequency of the recovered data stream is outside the limits set by the range controls, the CDR PLL will track REFCLK instead of the data stream. When the frequency of the selected data stream returns to a valid frequency, the CDR PLL is allowed to track the received data stream. The frequency of REFCLK is required to be within ± 200 ppm of the frequency of the clock that drives the REFCLK signal of the remote transmitter to ensure a lock to the incoming data stream.

For systems using multiple or redundant connections, the $\overline{\text{LFI}}$ output can be used to select an alternate data stream. When an LFI indication is detected, external logic can toggle selection of the input device. When such a port switch takes place, it is necessary for the PLL to re-acquire lock to the new serial stream.

External Filter

The CDR circuit uses external capacitors for the PLL filter. A 0.1- μF capacitor needs be connected between RXCN1 and RXCP1. Similarly a 0.1- μF capacitor needs to be connected between RXCN2 and RXCP2. The recommended capacitors for the external filters are 0805 NPO or 0603 NPO.

Deserialzer

The CDR circuit extracts bits from the serial data stream and clocks these bits into the Deserialzer at the bit-clock rate. The Deserialzer converts serial data into parallel data. RXD[15] is the most significant bit of the output word and is received first on the serial interface.

Loopback/Timing Modes

CY7B9532V supports various loopback modes as described below.

Facility Loopback (line loopback with retiming)

When the LINELOOP signal is set HIGH, the Facility Loopback mode is activated and the high-speed serial receive data (IN \pm) is presented to the high-speed transmit output (OUT \pm) after retiming. In Facility Loopback mode, the high-speed receive data (IN \pm) is also converted to parallel data and presented to the low-speed receive data output pins (RXD[15:0]). The receive recovered clock is also divided down and presented to the low speed clock output (RXCLK).

Equipment Loopback (diagnostic loopback with retiming)

When the DIAGLOOP signal is set HIGH, transmit data is looped back to the RX PLL, replacing IN \pm . Data is looped back from the parallel TX inputs to the parallel RX outputs. The data is looped back at the internal serial interface and goes through transmit shifter and the receive CDR. SD is ignored in this mode.

Line Loopback Mode (non-retimed data)

When the LOOPA signal is set HIGH, the RX serial data is directly buffered out to the transmit serial data. The data at the serial output is not retimed.

Loop Timing Mode

When the LOOPTIME signal is set HIGH, the TX PLL is bypassed and receive bit-rate clock is used for transmit side shifter.

Reset Modes

ALL logic circuits in the device can be reset using RESET and FIFO_RST signals. When RESET is set LOW, all logic circuits except FIFO are internally reset. When FIFO_RST is set LOW, the FIFO logic is reset.

Power-down Mode

CY7B9532 provides a global power-down signal $\overline{\text{PWRDN}}$. When LOW, this signal powers down the entire device to a minimal power dissipation state. RESET and FIFO_RST signals should be asserted LOW along with $\overline{\text{PWRDN}}$ signal to ensure low power dissipation.

PECL Compliance

The CY7B9532V HSTL parallel I/O can be configured to LVPECL compliance with slight termination modifications. On the transmit side of the transceiver, the TXD[15:0] and TXCLK can be made LVPECL compliant by setting V_{REF} (reference voltage of a LVPECL signal) to $V_{\text{CC}} - 1.33$ volts. To emulate a LVPECL signal on the receiver side of the transceiver, the transmission lines need to be terminated with the Thévenin equivalent of Z_0 at LVPECL ref. Next the signal is attenuated using a series resistor at the driver end of the line to reduce the HSTL voltage swing level to an LVPECL swing level (see Figure 6). This circuit needs to be used on all 16 RXD[15:0] pins and the RXCLK. The voltage divider has been calculated assuming the system is built with 50 Ω transmission lines.

DC Specifications
Table 1. DC Specifications - LVTTTL

Parameter	Description	Test Conditions	Min.	Max.	Unit
LVTTTL Outputs					
V _{OHT}	Output HIGH Voltage	V _{CC} = Min., I _{OH} = -10.0 mA	2.4		V
V _{OLT}	Output LOW Voltage	V _{CC} = Min., I _{OL} = 10.0 mA		0.4	V
I _{OS}	Output Short Circuit Current	V _{OUT} = 0V	-20	-90	mA
LVTTTL Inputs					
V _{IHT}	Input HIGH Voltage	Low = 2.0V High = V _{CC} + 0.5V	2.0	V _{CC} - 0.3	V
V _{ILT}	Input LOW Voltage	Low = -3.0V High = 0.8	-0.3	0.8	V
I _{IHT}	Input HIGH Current	V _{CC} = Max. V _{IN} = V _{CC}		50	μA
I _{ILT}	Input LOW Current	V _{CC} = Max. V _{IN} = 0V		-50	μA
Capacitance					
C _{IN}	Input Capacitance	V _{CC} = Max. @ f = 1 MHz		5	pF
C _{OUT}	Output Capacitance	V _{CC} = Max. @ f = 1 MHz		7	pF

Table 2. DC Specifications - Power

Parameter	Description	Test Conditions	Min.	Typical	Unit
Power					
I _{CC1}	Active Power Supply Current			400	mA
I _{SB}	Standby Current			1	mA

Table 3. DC Specifications - Differential PECL Input (REFCLK)

Parameter	Description	Test Conditions	Min.	Max.	Unit
Receiver PECL Compatible Inputs					
V _{INSGLE}	Input Single-ended Swing		200	600	mV
V _{DIFFE}	Input Differential Voltage		400	1200	mV
V _{IEHH}	Highest Input HIGH Voltage		V _{CC} - 1.2	V _{CC} - 0.3	V
V _{IELL}	Lowest Input LOW Voltage		V _{CC} - 2.0	V _{CC} - 1.45	V
I _{IEH}	Input HIGH Current	V _{IN} = V _{IEHH} Max.		750	μA
I _{IEL}	Input LOW Current	V _{IN} = V _{IELL} Min.	-200		μA
Capacitance					
C _{INE}	Input Capacitance			4	pF

Table 4. DC Specifications - Differential CML

Parameter	Description	Test Conditions	Min.	Max.	Unit
Transmitter CML Compatible Outputs					
V _{OHC}	Output HIGH Voltage (V _{CC} Referenced)	100Ω differential load	V _{CC} - 0.5	V _{CC} - 0.2	V
V _{OLC}	Output LOW Voltage (V _{CC} Referenced)	100Ω differential load	V _{CC} - 1.1	V _{CC} - 0.7	V
V _{DIFFOC}	Output Differential Swing	100Ω differential load	560	1500	mV
V _{SGLCO}	Output Single-ended Voltage	100Ω differential load	280	750	mV
Receiver CML Compatible Inputs					
V _{INSGLC}	Input Single-ended Swing		125	600	mV
V _{DIFFC}	Input Differential Voltage		250	1200	mV
V _{ICHH}	Highest Input HIGH Voltage			V _{CC}	V
V _{ICLL}	Lowest Input LOW Voltage		1.2		V
I _{ICH}	Input HIGH Current	V _{IN} = V _{ICHH} Max.		47	mA
I _{ICL}	Input LOW Current	V _{IN} = V _{ICLL} Min.		20	mA
Capacitance					
C _{INC}	Input Capacitance			4	pF

Table 5. DC Specifications - HSTL

Parameter	Description	Test Conditions	Min.	Max.	Unit
HSTL Outputs					
V _{OHH}	Output HIGH Voltage	V _{CC} = Min., I _{OH} = -4.0 mA	V _{DDQ} - 0.4		V
V _{OLH}	Output LOW Voltage	V _{CC} = Min., I _{OL} = 4.0 mA		0.4	V
I _{OSH}	Output Short Circuit Current	V _{OUT} = 0V		100	mA
HSTL Inputs					
V _{IHH}	Input HIGH Voltage		V _{REF} + 0.1	V _{DDQ} + 0.3	V
V _{ILH}	Input LOW Voltage		-0.3	V _{REF} - 0.1	V
I _{IHH}	Input HIGH Current	V _{DDQ} = Max. V _{IN} = V _{DDQ}		50	μA
I _{ILH}	Input LOW Current	V _{DDQ} = Max. V _{IN} = 0V		-40	μA
Capacitance					
C _{INH}	Input Capacitance	V _{DDQ} = Max. @ f = 1 MHz		5	pF
C _{OUTH}	Output Capacitance	V _{DDQ} = Max. @ f = 1 MHz		7	pF

AC Specifications
Table 6. AC Specifications - HSTL Parallel Interface

Parameter	Description	Min.	Max.	Unit
t_{TS}	TXCLK Frequency (must be frequency coherent to REFCLK when used as the TXPLL clock source)	154.5	156.5	MHz
t_{TXCLKI}	TXCLKI Period	6.38	6.47	ns
$t_{TXCLKID}$	TXCLKI Duty Cycle	40	60	%
t_{TXCLKR}	TXCLK Rise Time	0.3	1.5	ns
t_{TXCLKF}	TXCLK Fall Time	0.3	1.5	ns
t_{TXDS}	Write Data Set-up to \uparrow of TXCLKI	1		ns
t_{TXDH}	Write Data Hold from \uparrow of TXCLK	1		ns
t_{RS}	RXCLK Frequency	154.5	156.5	MHz
t_{RXCLKO}	RXCLKO Period	6.38	6.47	ns
$t_{RXCLKOD}$	RXCLKO Duty Cycle	43	57	%
$t_{RXCLKOR}$	RXCLKO Rise Time	0.3	1.5	ns
$t_{RXCLKOF}$	RXCLKO Fall Time	0.3	1.5	ns
t_{RXDS}	Recovered Data Set-up to \uparrow of RXCLKO	2.5		ns
t_{RXDH}	Recovered Data Hold from \uparrow of RXCLKO	2		ns

Table 7. AC Specifications - REFCLK

Parameter	Description	Min.	Max.	Unit
t_{REF}	REFCLK Input Frequency	154.5	156.5	MHz
t_{REFP}	REFCLK Period	6.38	6.47	ns
t_{REFD}	REFCLK Duty Cycle	35	75	%
t_{REFT}	REFCLK Frequency Tolerance (relative to received serial data)	-100	+100	ppm
t_{REFR}	REFCLK Rise Time	0.3	1.5	ns
t_{REFF}	REFCLK Fall Time	0.3	1.5	ns

Table 8. AC Specifications - CML Serial Outputs

Parameter	Description	Min.	Max.	Unit
t_{RISE}	CML Output Rise Time (20–80%, 100 Ω balanced load)	60	170	ps
t_{FALL}	CML Output Fall Time (80–20%, 100 Ω balanced load)	60	170	ps
t_{TJ}	Total Output Jitter (p-p)		0.1	UI
	Total Output Jitter (rms)		0.01	UI

AC Test Loads and Waveforms

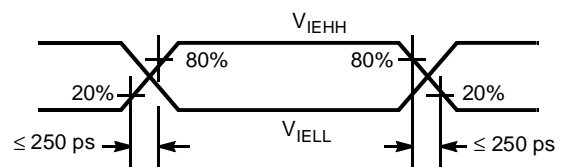
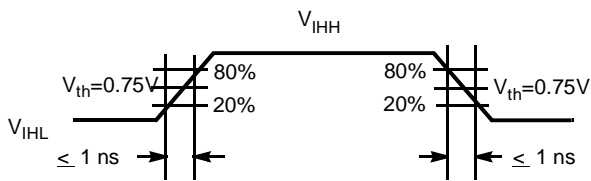
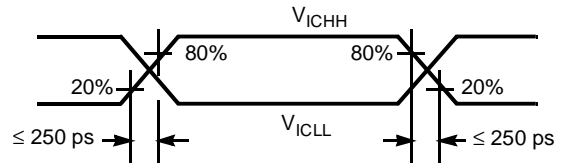
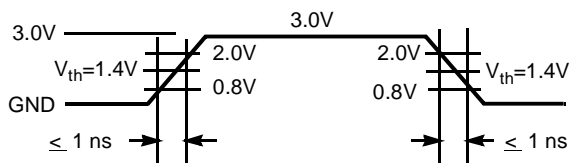
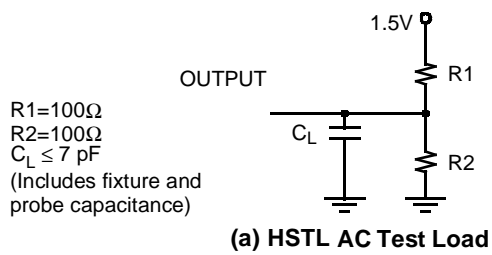
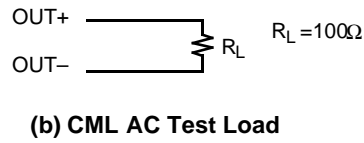
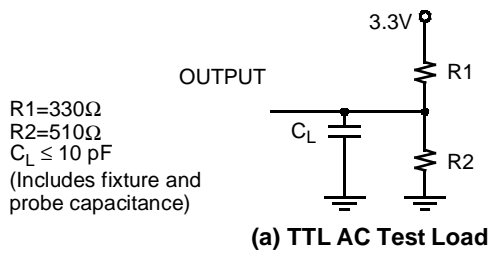

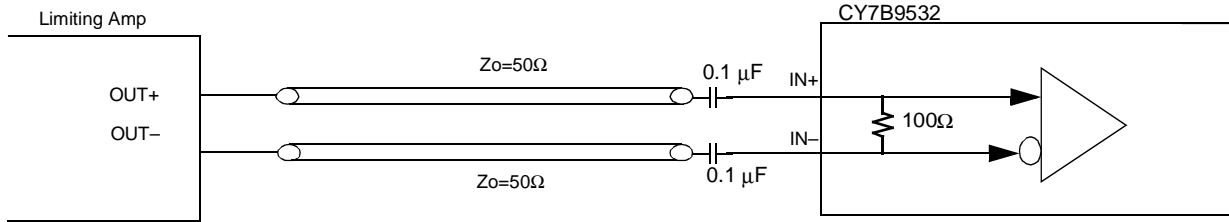
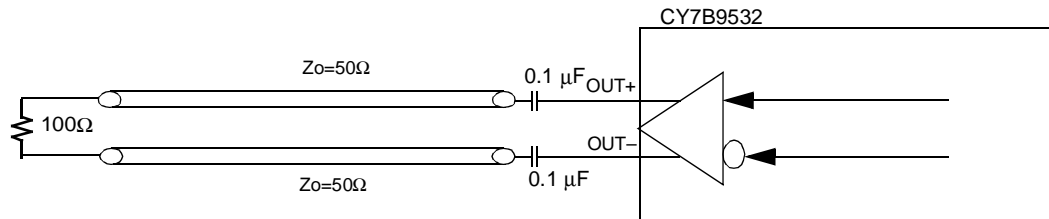
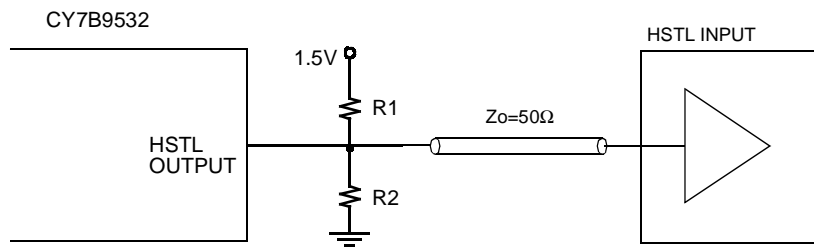
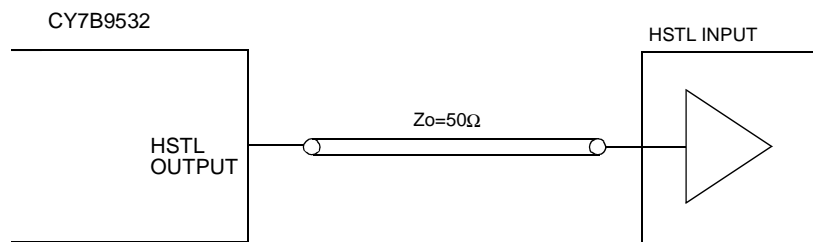
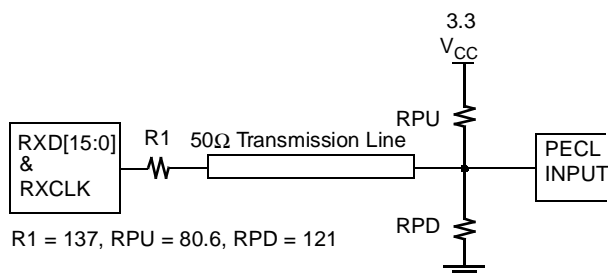
Figure 2. Serial Input Termination

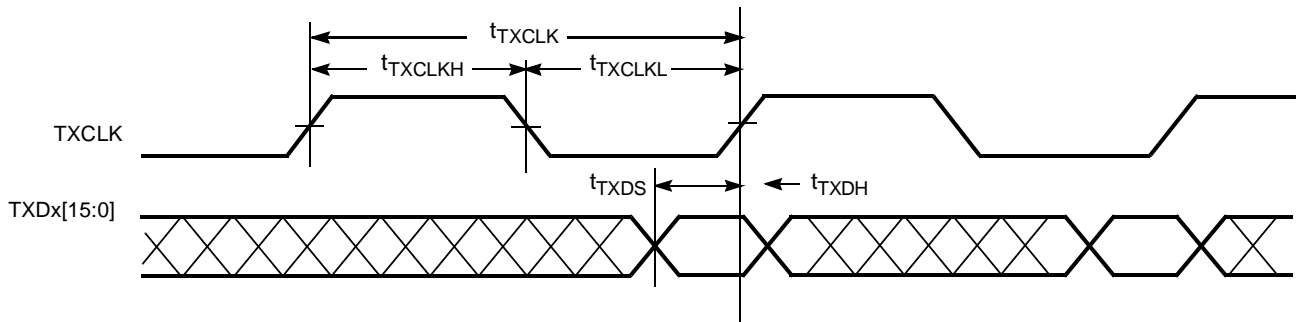
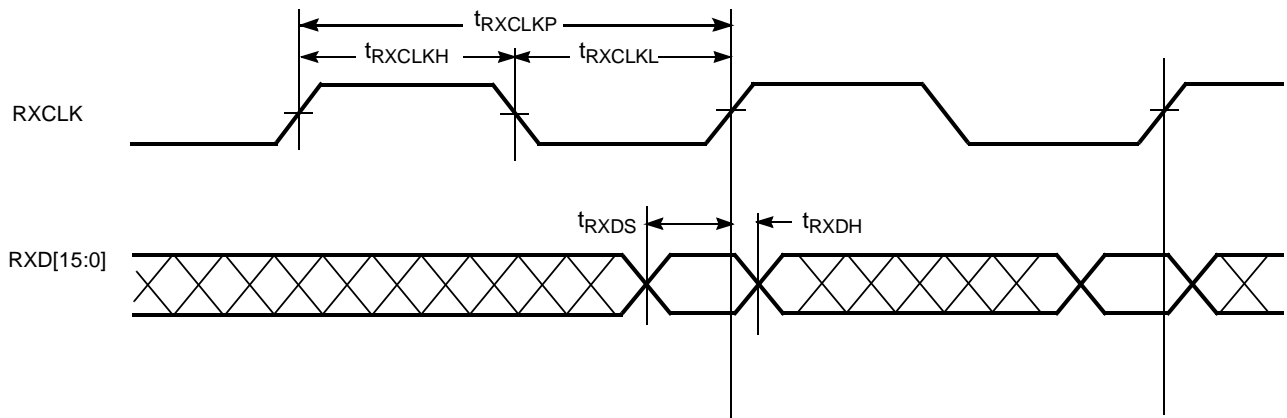
Figure 3. Serial Output Termination

Figure 4. TXCLKO/ RXCLK Termination

Figure 5. RXD[15:0] Termination

Figure 6. LVPECL Compliant Termination

Switching Waveforms
Transmit Interface Timing

Receive Interface Timing

Ordering Information

Speed	Ordering Code	Package Name	Package Type	Operating Range
Standard	CY7B9532-AC	A120	120-pin TQFP	Commercial
Standard	CY7B9532-AI	A120	120-pin TQFP	Industrial

Document #: 38-00894

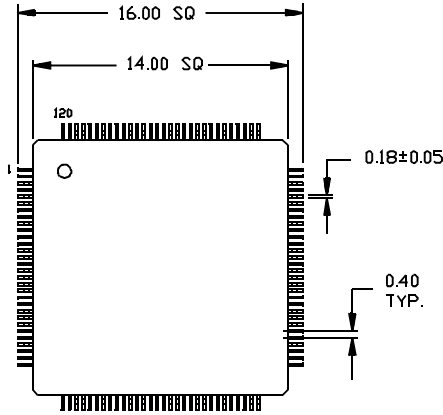
Package Diagram

120-Pin Thin Quad Flatpack (14 x 14 x 1.4 mm) A120



DIMENSIONS IN MILLIMETERS

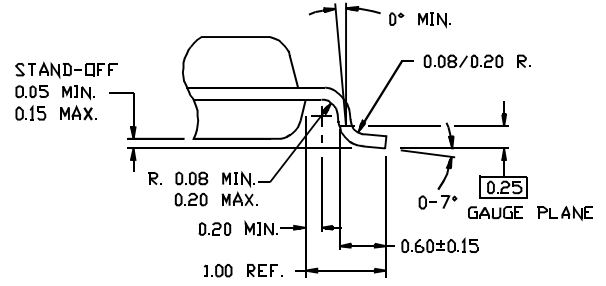

DETAIL "A"

51-85100

