

SKiiP 1513GB172-3DL

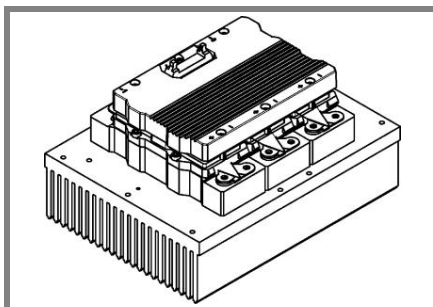

SKiiP® 3

2-pack-integrated intelligent Power System

Power section

SKiiP 1513GB172-3DL

Preliminary Data

Features

- SKiiP technology inside
- Trench IGBTs
- CAL diode technology
- Integrated current sensor
- Integrated temperature sensor
- Integrated heat sink
- IEC 60721-3-3 (humidity) class 3K3/IE32 (SKiiP® 3 System)
- IEC 60068-1 (climate) 40/125/56
- UL recognized file no. E63532

- 1) with assembly of suitable MKP capacitor per terminal (SEMIKRON type is recommended)
- 8) AC connection busbars must be connected by the user; copper busbars available on request

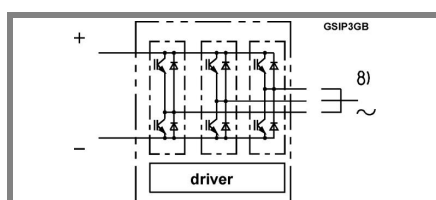

Case S33

Absolute Maximum Ratings		$T_s = 25\text{ }^\circ\text{C}$, unless otherwise specified	
Symbol	Conditions	Values	Units
IGBT			
V_{CES}	Operating DC link voltage	1700	V
$V_{CC}^{1)}$		1200	V
V_{GES}		± 20	V
I_C	$T_s = 25\text{ (70) }^\circ\text{C}$	1500 (1125)	A
Inverse diode			
$I_F = -I_C$	$T_s = 25\text{ (70) }^\circ\text{C}$	1250 (950)	A
I_{FSM}	$T_j = 150\text{ }^\circ\text{C}$, $t_p = 10\text{ ms}$; sin	10200	A
I^2t (Diode)	Diode, $T_j = 150\text{ }^\circ\text{C}$, 10 ms	520	kA ² s
T_j ; (T_{stg})	rms, AC, 1 min, main terminals to heat sink per AC terminal, rms, $T_s = 70\text{ }^\circ\text{C}$, $T_{terminal} < 115\text{ }^\circ\text{C}$	- 40 ... + 150 (125)	$^\circ\text{C}$
V_{isol}		4000	V
$I_{AC-terminal}$		400	A

Characteristics		$T_s = 25\text{ }^\circ\text{C}$, unless otherwise specified							
Symbol	Conditions	min.	typ.	max.	Units				
IGBT									
V_{CEsat}	$I_C = 900\text{ A}$, $T_j = 25\text{ (125) }^\circ\text{C}$; measured at terminal		1,9 (2,2)	2,4	V				
V_{CEO}	$T_j = 25\text{ (125) }^\circ\text{C}$; at terminal		1 (0,9)	1,2 (1,1)	V				
r_{CE}	$T_j = 25\text{ (125) }^\circ\text{C}$; at terminal		1 (1,4)	1,3 (1,7)	m Ω				
I_{CES}	$V_{GE} = 0\text{ V}$, $V_{CE} = V_{CES}$, $T_j = 25\text{ (125) }^\circ\text{C}$		3,6 (216)		mA				
$E_{on} + E_{off}$	$I_C = 900\text{ A}$, $V_{CC} = 900\text{ V}$		585		mJ				
	$T_j = 125\text{ }^\circ\text{C}$, $V_{CC} = 1200\text{ V}$		863		mJ				
R_{CC+EE}	terminal chip, $T_j = 25\text{ }^\circ\text{C}$		0,17		m Ω				
L_{CE}	top, bottom		4		nH				
C_{CHC}	per phase, AC-side		5,1		nF				
Inverse diode									
$V_F = V_{EC}$	$I_F = 900\text{ A}$, $T_j = 25\text{ (125) }^\circ\text{C}$ measured at terminal		2 (1,8)	2,15	V				
V_{TO}	$T_j = 25\text{ (125) }^\circ\text{C}$		1,1 (0,8)	1,2 (0,9)	V				
r_T	$T_j = 25\text{ (125) }^\circ\text{C}$		1 (1,1)	1,1 (1,2)	m Ω				
E_{rr}	$I_C = 900\text{ A}$, $V_{CC} = 900\text{ V}$		108		mJ				
	$T_j = 125\text{ }^\circ\text{C}$, $V_{CC} = 1200\text{ V}$		128		mJ				
Mechanical data									
M_{dc}	DC terminals, SI Units	6		8	Nm				
M_{ac}	AC terminals, SI Units	13		15	Nm				
w	SKiiP® 3 System w/o heat sink		2,4		kg				
w	heat sink		7,5		kg				
Thermal characteristics (PX 16 heat sink with fan SKF16B-230-1); "s" reference to heat sink; "r" reference to built-in temperature sensor (acc.IEC 60747-15)									
$R_{th(j-s)I}$	per IGBT			0,02	K/W				
$R_{th(j-s)D}$	per diode			0,038	K/W				
Z_{th}	R_i (mK/W) (max. values)	tau _i (s)							
		1	2	3	4				
$Z_{th(j-r)I}$		3,4	9,6	7	0	363	0,18	0,04	1
$Z_{th(j-r)D}$		12	12	18	20	30	5	0,25	0,04
$Z_{th(r-a)}$		2,1	20	5,5	1,4	210	85	11	0,4

This technical information specifies semiconductor devices but promises no characteristics. No warranty or guarantee, expressed or implied is made regarding delivery, performance or suitability.

SKiiP 1513GB172-3DL

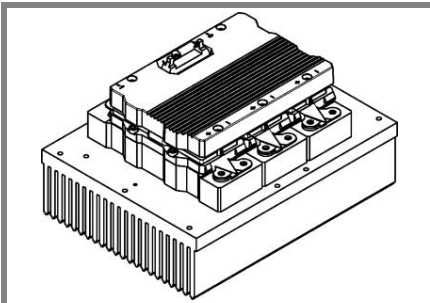

SKiiP® 3

2-pack-integrated intelligent Power System

2-pack
integrated gate driver
SKiiP 1513GB172-3DL

Preliminary Data

Gate driver features

- CMOS compatible inputs
- Wide range power supply
- Integrated circuitry to sense phase current, heat sink temperature and DC-bus voltage (option)
- Short circuit protection
- Over current protection
- Over voltage protection (option)
- Power supply protected against under voltage
- Interlock of top/bottom switch
- Isolation by transformers
- Fibre optic interface (option for GB-types only)
- IEC 60068-1 (climate) 40/85/56
- UL recognized file no. 242581

Absolute Maximum Ratings		$T_a = 25\text{ }^\circ\text{C}$, unless otherwise specified	
Symbol	Conditions	Values	Units
V_{S2}	unstabilized 24 V power supply	30	V
V_i	input signal voltage (high)	15 + 0,3	V
dv/dt	secondary to primary side	75	kV/ μ s
V_{isolIO}	input / output (AC, rms, 2 s)	4000	V
V_{isolPD}	partial discharge extinction voltage, rms, $Q_{PD} \leq 10\text{ pC}$;	1500	V
V_{isol12}	output 1 / output 2 (AC, rms, 2 s)	1500	V
f_{sw}	switching frequency	9	kHz
f_{out}	output frequency for $I=I_C$; sin.	1	kHz
T_{op} (T_{stg})	operating / storage temperature	- 40 ... + 85	$^\circ\text{C}$

Characteristics		$(T_a = 25\text{ }^\circ\text{C})$			
Symbol	Conditions	min.	typ.	max.	Units
V_{S2}	supply voltage non stabilized	13	24	30	V
I_{S2}	$V_{S2} = 24\text{ V}$	$380+34*f/\text{kHz}+0,00015*(I_{AC}/A)^2$			mA
V_{iT+}	input threshold voltage (High)			12,3	V
V_{iT-}	input threshold voltage (Low)	4,6			V
R_{IN}	input resistance		10		k Ω
C_{IN}	input capacitance		1		nF
$t_{d(on)IO}$	input-output turn-on propagation time		1,3		μ s
$t_{d(off)IO}$	input-output turn-off propagation time		1,3		μ s
$t_{pERRRESET}$	error memory reset time		9		μ s
t_{TD}	top / bottom switch interlock time		3,3		μ s
$I_{analogOUT}$	max. 5 mA; 8 V corresponds to 15 V supply voltage for external components		1500		A
I_{s1out}	max. load current			50	mA
I_{TRIPSC}	over current trip level ($I_{analog\ OUT} = 10\text{ V}$)		1875		A
T_{tp}	over temperature protection	110		120	$^\circ\text{C}$
U_{DCTRIP}	U_{DC} -protection ($U_{analog\ OUT} = 9\text{ V}$); (option for GB types)		not implemented		V

For electrical and thermal design support please use SEMISEL.
Access to SEMISEL is via SEMIKRON website <http://www.semikron.com>.

This technical information specifies semiconductor devices but promises no characteristics. No warranty or guarantee, expressed or implied is made regarding delivery, performance or suitability.

