

GND ISOLATOR

TA7414P is a ground isolator IC for car audio equipments.

This IC is contain dual channel differential amplifier and audio muting circuit.

- Dual Channel Differential Amplifier

- High Common Mode Rejection Ratio

CMRR=55dB(Typ.)

(f=1kHz, $V_{CM}=-10dBm$)

- Low Distortion

THD=0.01%(Typ.)

($V_{OUT}=100mV_{rms}$)

- Low Noise

$V_{NO}=5\mu V_{rms}$ (Typ.)

($R_g=10k\Omega$, BW=20Hz~20kHz)

- Audio Muting Circuit

Attenuation=80dB(Typ.)

($V_{OUT}=-10dBm$)

- Operating Supply Voltage

$V_{CC(opr)}=8\sim 16V$

Unit in mm

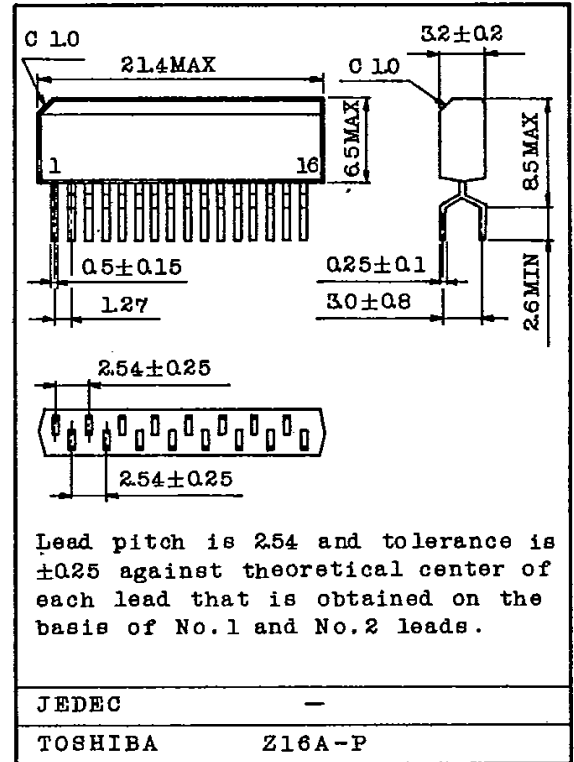

Weight : 1.0g (TYP.)

MAXIMUM RATINGS (Ta=25°C)

CHARACTERISTIC	SYMBOL	RATING	UNIT
Peak Supply Voltage*	$V_{CC(surge)}$	50	V
Supply Voltage	V_{CC}	18	V
Power Dissipation (Note)	PD	750	mW
Operating Temperature	T_{opr}	-30~75	°C
Storage Temperature	T_{stg}	-55~150	°C

* Condition : Series resistance 100Ω insert Pin ① (V_{CC})

Note: Derated above $T_a=25^\circ C$ in the proportion of 6mW/°C.

ELECTRICAL CHARACTERISTICS

(Unless otherwise specified, $V_{CC}=13.2V$, $R_L=15k\Omega$, $f=1kHz$, $T_a=25^\circ C$)

CHARACTERISTIC	SYMBOL	TEST CIR-CUIT	TEST CONDITION	MIN.	TYP.	MAX.	UNIT
Quiescent Current	I_{CCQ}	1	$V_{NO}=0$, MUTE:OFF	-	3	5	mA
Voltage Gain	G_V	1	$V_{OUT}=-10dBm$	-2	0	2	dB
Maximum Output Voltage	V_{OM}	1	$V_{CC}=8V$, THD=0.1%	-10	-8	-	dBm
Total Harmonic Distortion	THD	1	$V_{OUT}=100mV_{rms}$ $BW=400Hz\sim 80kHz$	-	0.01	0.03	%
Cross Talk	C.T	1	$V_{IN}=-10dBm$	-	65	-	dB
Input Impedance	Z_i	1	$V_{OUT}=-10dBm$	-	70	-	$k\Omega$
Output Impedance	Z_o	1	$V_{OUT}=-20dBm$	-	0.45	-	$k\Omega$
Output Noise Voltage	V_{NO}	2	$R_g=10k\Omega$, $BW=20Hz\sim 20kHz$	-	5	10	μV_{rms}
Muting Attenuation	ATT	3	$V_{OUT}=-10dBm$	60	80	-	dB
Muting Threshold Voltage	V_M	3	ATT=3dB	1.7	2.2	2.7	V
Common Mode Rejection Ratio	CMRR	4	$V_{CM}=-10dBm$	46	55	-	dB
Common Mode Input Voltage	$V_{CM}(MAX)$	4	$V_{CC}=8V$, CMRR=40dB	1.0	1.6	-	V_{rms}

BLOCK DIAGRAM

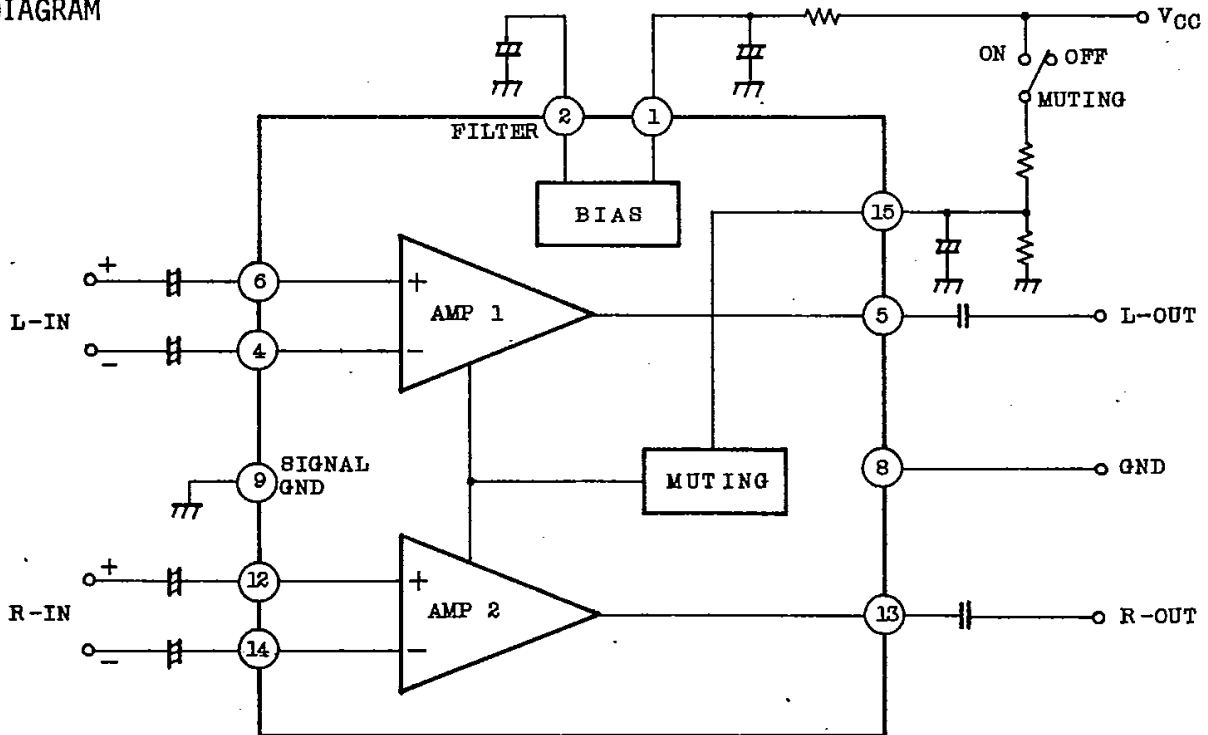

③ : OPEN

⑦ ⑩ ⑪ ⑮ ⑯ : CONNECT TO GND OR OPEN

TEST CIRCUIT 1

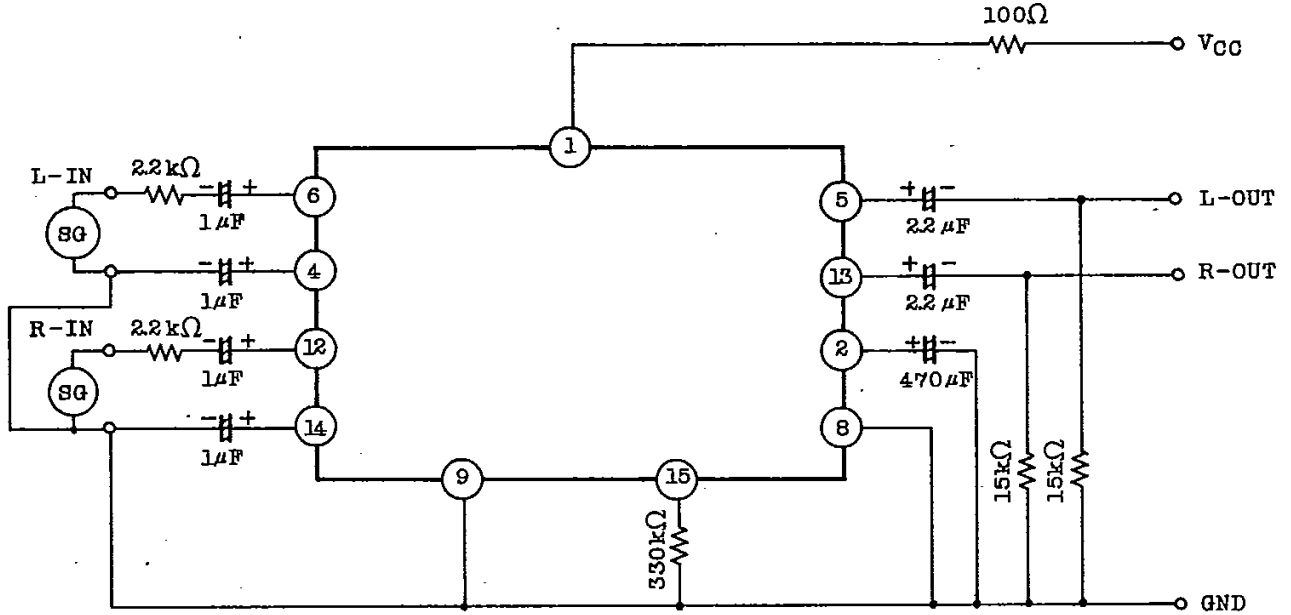

TEST CIRCUIT 2

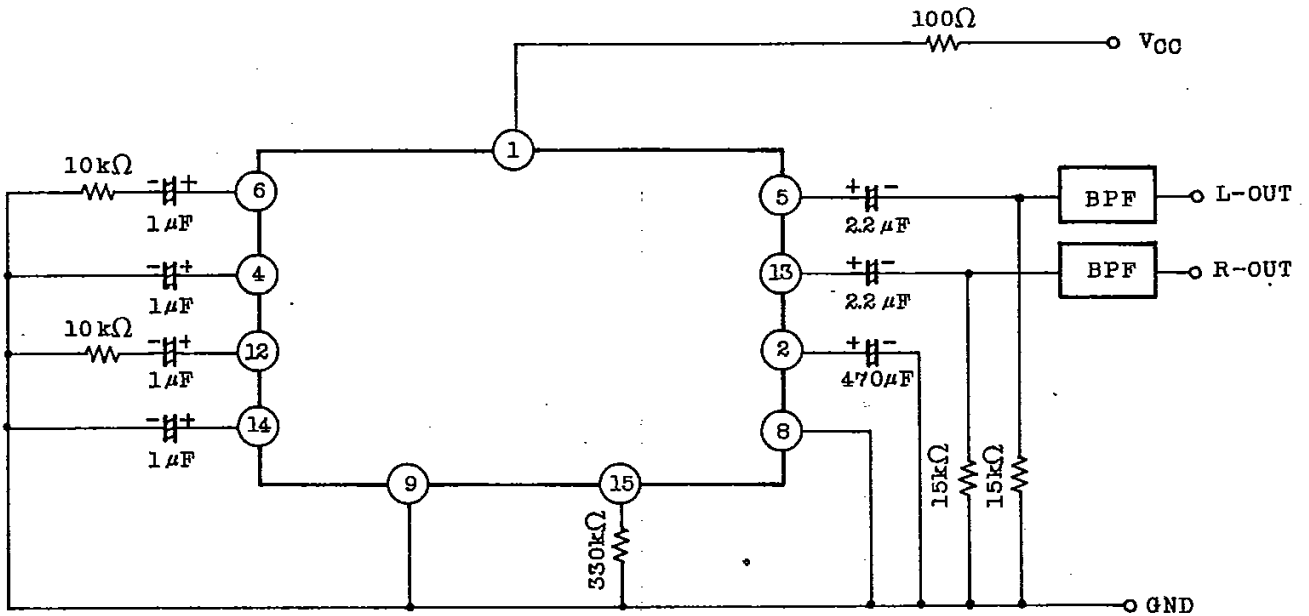

APPLICATION CIRCUIT

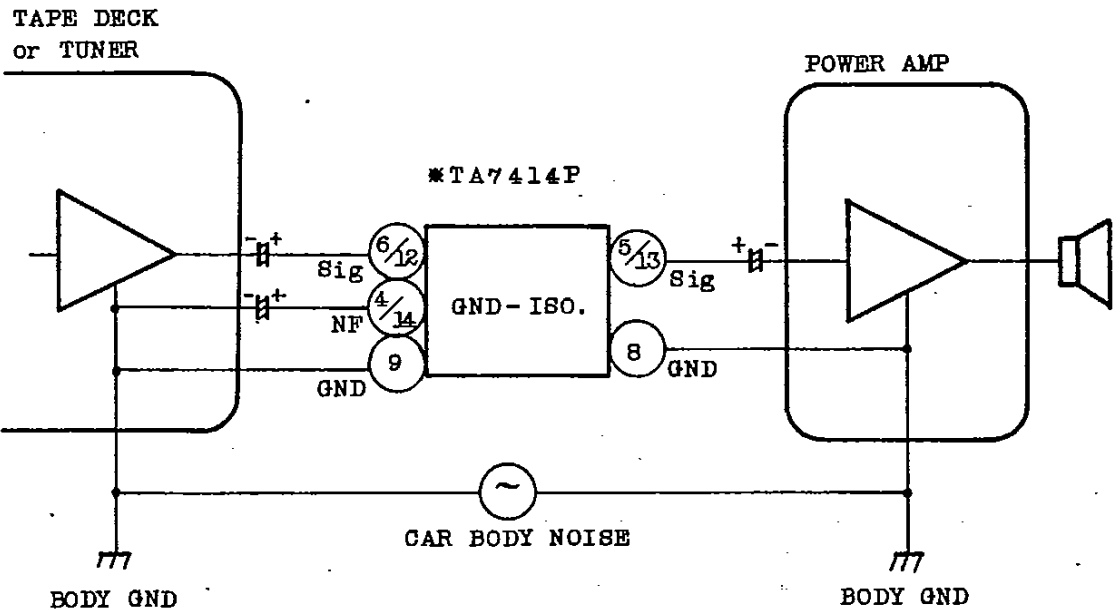
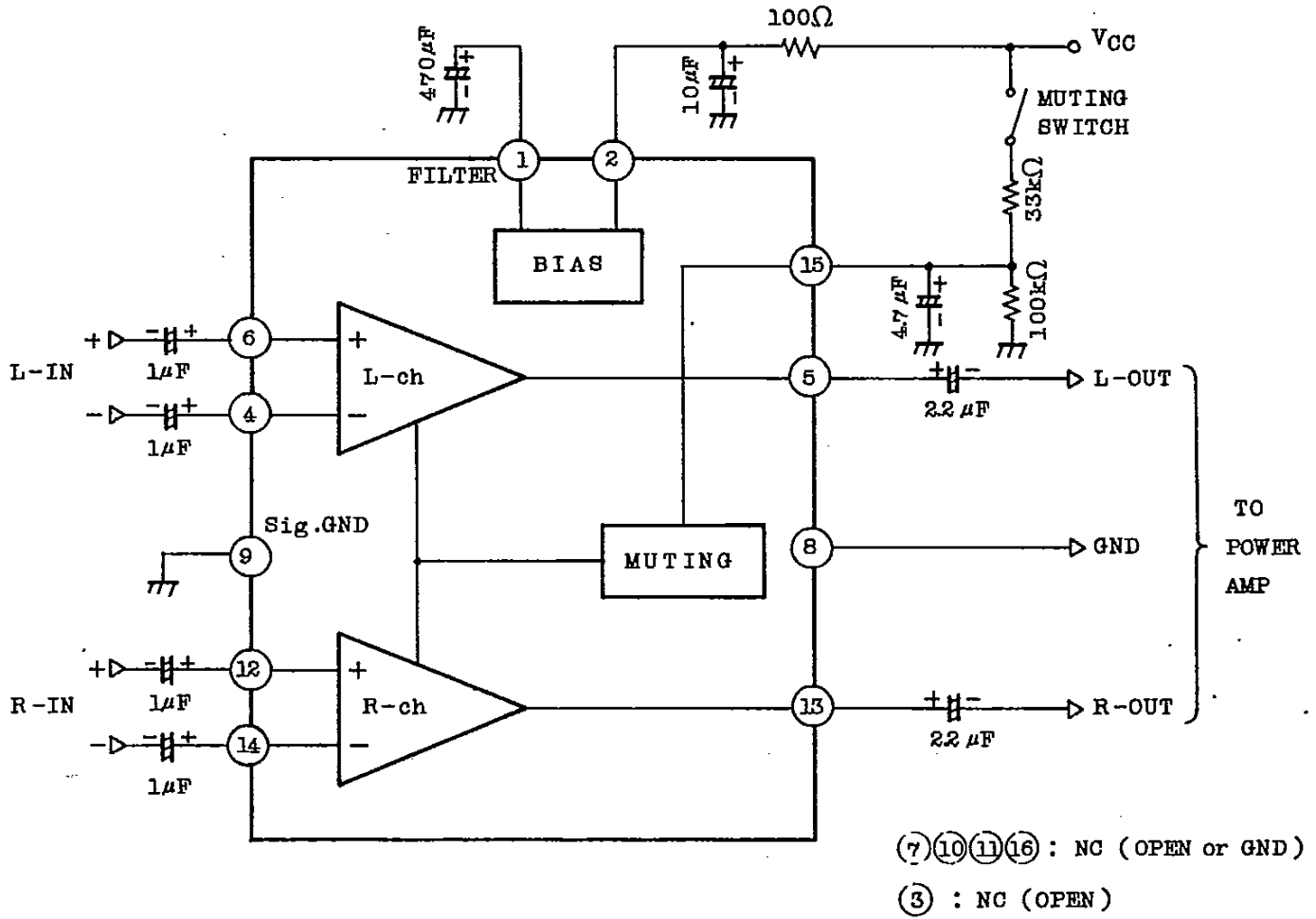

TA7414P

THD - V_{OUT}

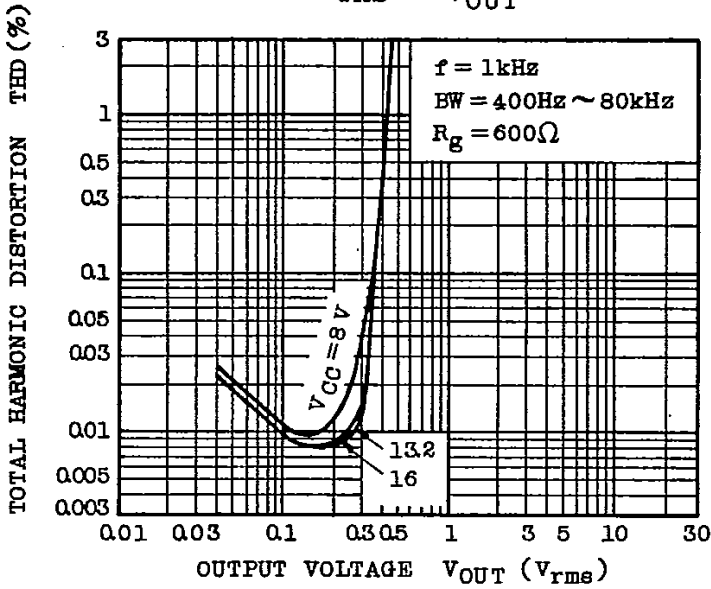

THD - V_{CC}

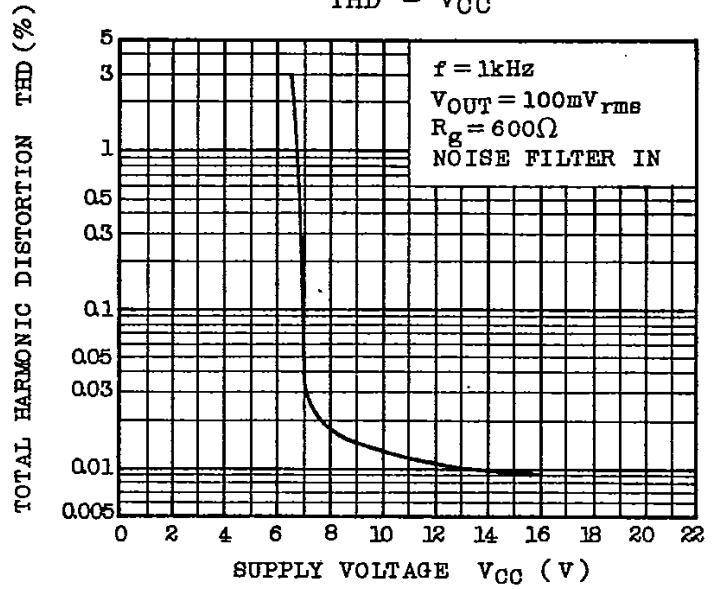

CMRR - V_{CM}

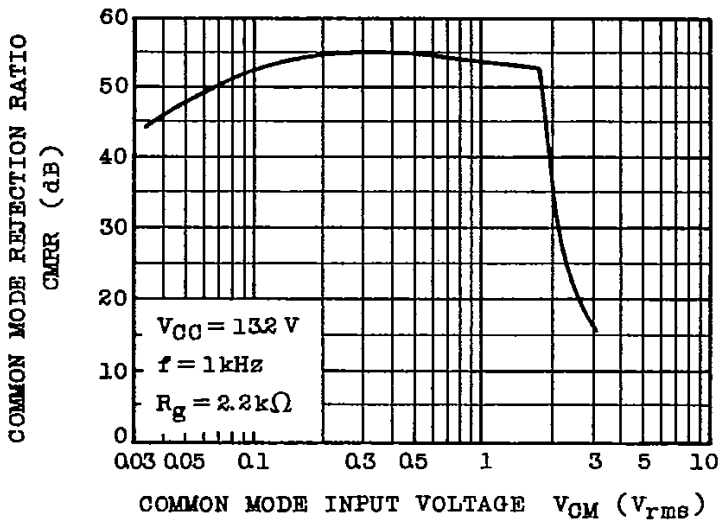

THD - f

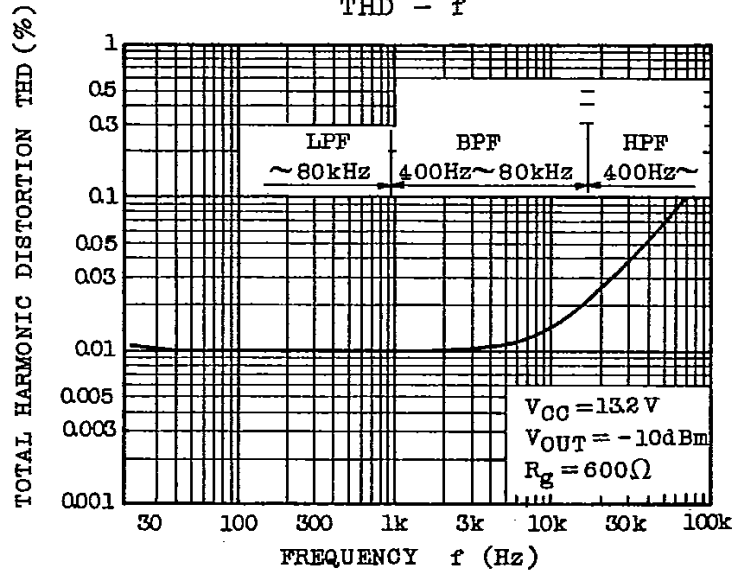

G_V - f

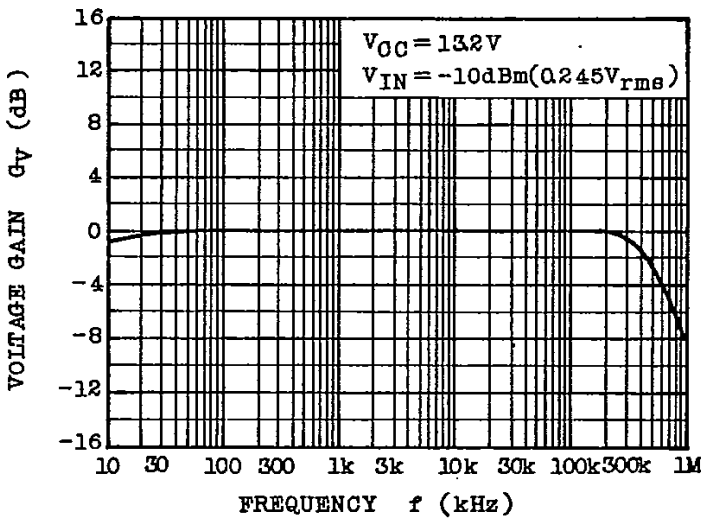

G_V - V_{CC}

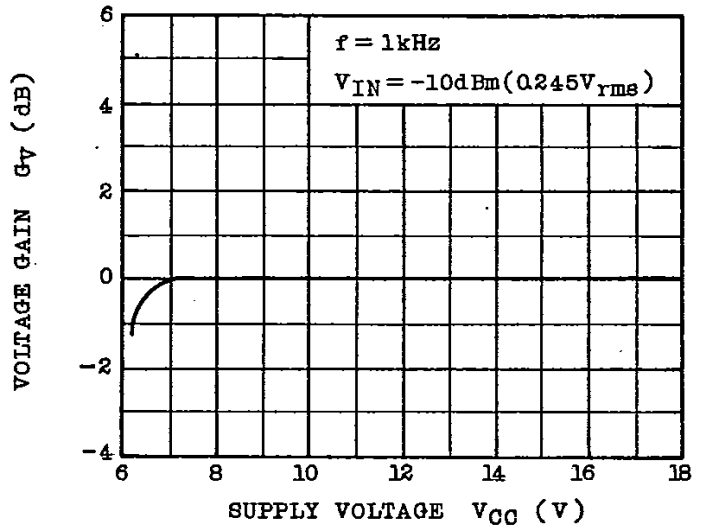

$V_{NO} - R_g$

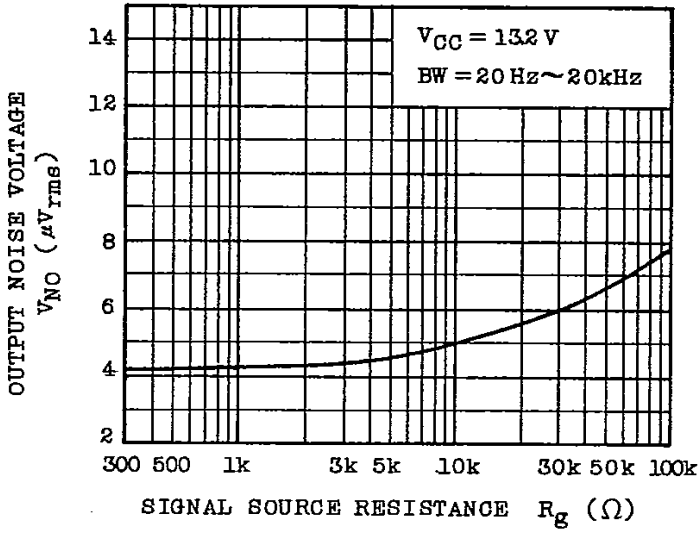

ATT - V_M

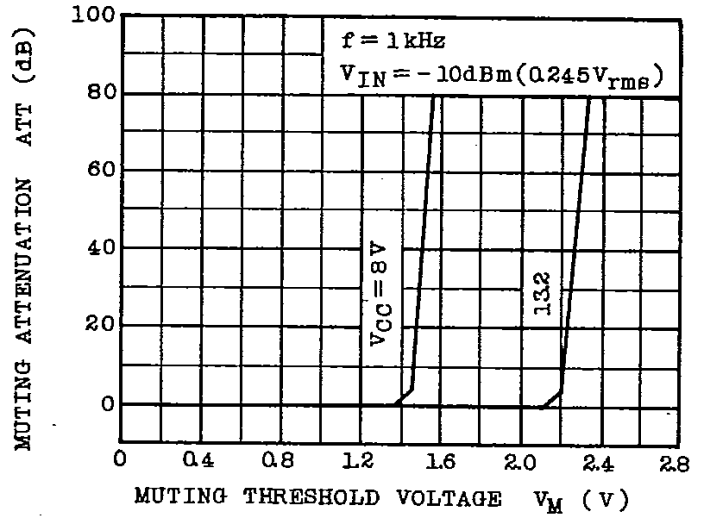

$V_{CM}(MAX), I_{CCQ} - T_a$

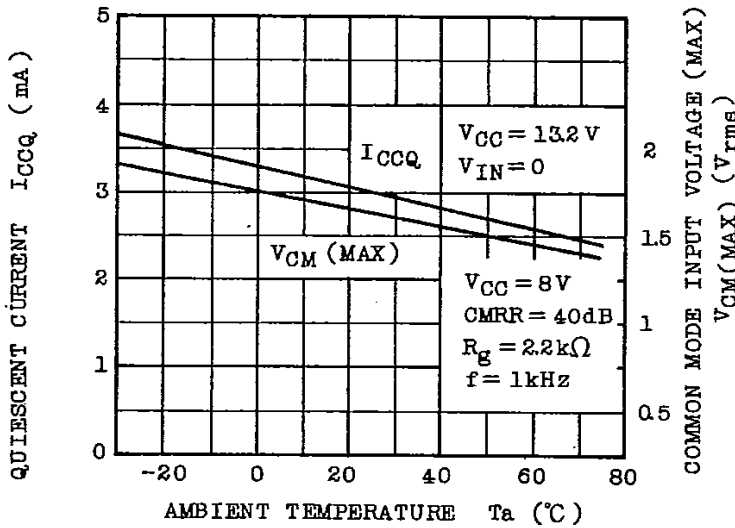

$G_V, THD - T_a$

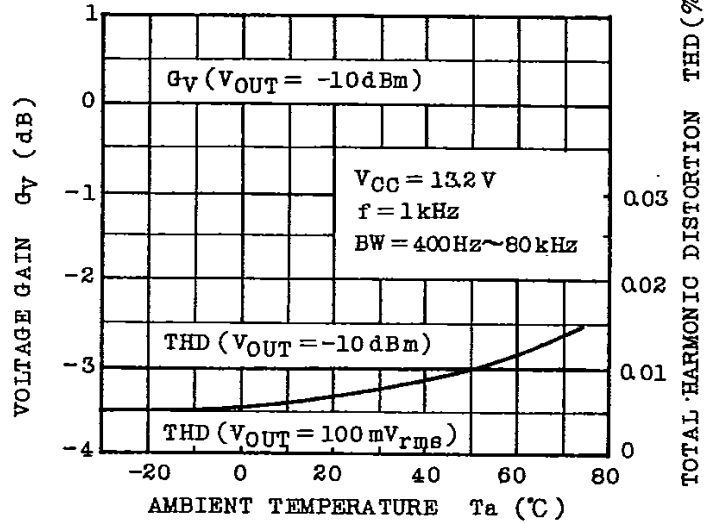

$I_{CCQ}, V_o - V_{CC}$

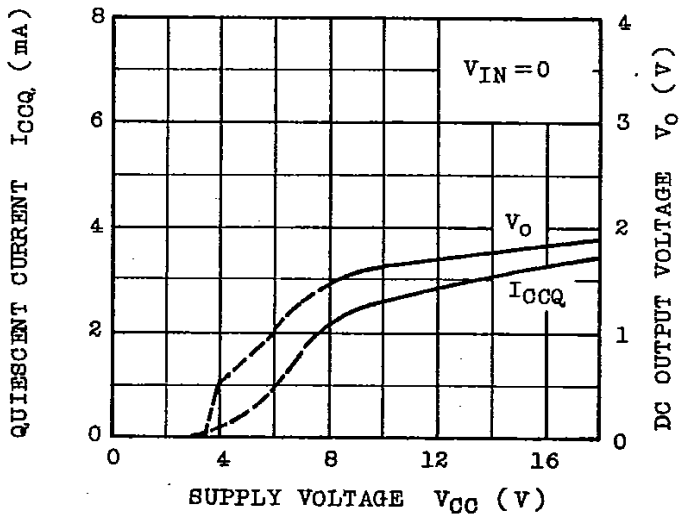

CMRR - T_a

