



Description

The MK1726-08 generates a low EMI output clock and a reference clock from a clock or crystal input. The part is designed to lower EMI through the application of spreading a clock. Using ICS' proprietary mix of analog and digital Phase-Locked Loop (PLL) technology, the device spreads the frequency spectrum of the output, reducing the frequency amplitude peaks by several dB depending on spread range. The MK1726-08 offers a range of down spread from a high speed clock or crystal input. The MK1726-08 generates one modulated (SSCLK) and unmodulated (REFCLK) clock and is compatible with Cypress CY25819. The modulated clock is controlled by the select pin, and the unmodulated clock has the same frequency as the input clock or crystal.

Features

- Packaged in 8-pin SOIC
- Available in Pb (lead) free package
- Input frequency range 16- 32 MHz
- Provides modulated and unmodulated clocks
- Accepts a clock or crystal input
- Provides down spread modulation
- Provides power down function
- Reduce electromagnetic interference (EMI) by 8-16 db
- Operating voltage of 3.3 V
- Advanced, low-power CMOS process

Block Diagram

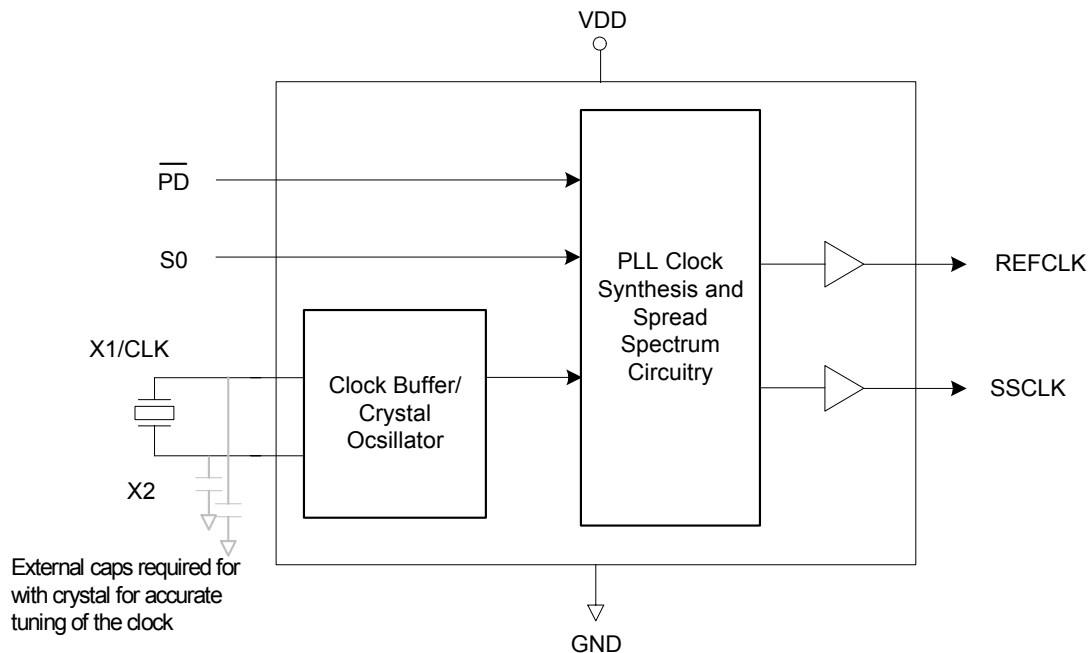



Pin Assignment

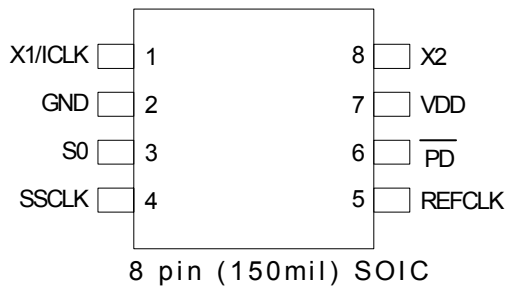

Spread Percentage Select Table

S0	Spread Direction	Spread Percentage (%)
0	Down	-1.8
1	Down	-2.5
M	Down	-0.6

0 = connect to GND

M= unconnected

1 = connect directly to VDD

* Default has internal pull up resistor to VDD

Pin Descriptions

Pin Number	Pin Name	Pin Type	Pin Description
1	X1/ICLK	Input	Connect to 16-32 MHz crystal or clock.
2	GND	Power	Connect to ground.
3	S0	Input	Select spread percentage per table above. Internal pull-up.
4	SSCLK	Output	Spread spectrum clock output per table above.
5	REFCLK	Power	CMOS level clock output matches the nominal frequency of the input crystal or clock.
6	$\overline{\text{PD}}$	Input	Power down tri-state. This pin powers down entire chip and tri-state the outputs when low. Internal pull-up.
7	VDD	Power	Connect to 3.3 V.
8	X2	Input	Connect to 16-32 MHz crystal or leave unconnected.



External Components

The MK1726-08 requires a minimum number of external components for proper operation.

Decoupling Capacitor

A decoupling capacitor of 0.01 μ F must be connected between VDD and GND, as close to these pins as possible. For optimum device performance, the decoupling capacitor should be mounted on the component side of the PCB. Avoid the use of vias in the decoupling circuit.

Series Termination Resistor

When the PCB trace between the clock output and the load is over 1 inch, series termination should be used. To series terminate a 50 Ω trace (a commonly used trace impedance) place a 33 Ω resistor in series with the clock line, as close to the clock output pin as possible. The nominal impedance of the clock output is 20 Ω .

PCB Layout Recommendations

For optimum device performance and lowest output phase noise, the following guidelines should be observed.

- 1) The 0.01 μ F decoupling capacitor should be mounted on the component side of the board as close to the VDD pin as possible. No vias should be used between the decoupling capacitor and VDD pin. The PCB trace to VDD pin should be kept as short as possible, as should the PCB trace to the ground via.
- 2) To minimize EMI, the 33 Ω series termination resistor (if needed) should be placed close to the clock output.
- 3) An optimum layout is one with all components on the same side of the board, minimizing vias through other signal layers. Other signal traces should be routed

away from the MK1726-08. This includes signal traces just underneath the device, or on layers adjacent to the ground plane layer used by the device.

Crystal Information

The crystal used should be a fundamental mode (do not use third overtone), parallel resonant. Crystal capacitors should be connected from pins X1 to ground and X2 to ground to optimize the initial accuracy. The value of these capacitors is given by the following equation:

$$\text{Crystal caps (pF)} = (C_L - 6) \times 2$$

In the equation, C_L is the crystal load capacitance. So, for a crystal with a 16 pF load capacitance, two 20 pF [(16-6) x 2] capacitors should be used.

Spread Spectrum Profile

The MK1726-08 low EMI clock generator uses an optimized frequency slew rate algorithm to facilitate down stream tracking of zero delay buffers and other PLL devices. The frequency modulation amplitude is constant with variations of the input frequency.

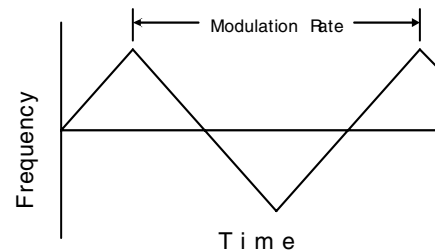



Absolute Maximum Ratings

Stresses above the ratings listed below can cause permanent damage to the MK1726-08. These ratings, which are standard values for ICS commercially rated parts, are stress ratings only. Functional operation of the device at these or any other conditions above those indicated in the operational sections of the specifications is not implied. Exposure to absolute maximum rating conditions for extended periods can affect product reliability. Electrical parameters are guaranteed only over the recommended operating temperature range.

Item	Rating
Supply Voltage, VDD	7 V
All Inputs and Outputs	-0.5 V to VDD+0.5 V
Ambient Operating Temperature	0 to +70°C
Storage Temperature	-65 to +150°C
Junction Temperature	125°C
Soldering Temperature	260°C

Recommended Operation Conditions

Parameter	Min.	Typ.	Max.	Units
Ambient Operating Temperature	0		+70	°C
Power Supply Voltage (measured in respect to GND)	+2.97		3.63	V

DC Electrical Characteristics

Unless stated otherwise, **VDD = 3.3 V ±10%**, Ambient Temperature 0 to +70°C

Parameter	Symbol	Conditions	Min.	Typ.	Max.	Units
Power Supply Range	V _{DD}		2.97	3.3	3.63	V
Input High Voltage	V _{INH}	S0 Input	0.85 V _{DD}	V _{DD}	V _{DD}	V
Input Middle Voltage	V _{INM}	S0 Input	0.40 V _{DD}	0.50 V _{DD}	0.60 V _{DD}	V
Input Low Voltage	V _{INL}	S0 Input	0.0	0.0	0.15 V _{DD}	V
Output High Voltage	V _{OH1}	I _{OH} =4 ma, SSCLK and REFCLK	2.4			V
Output High Voltage	V _{OH2}	I _{OH} =6 ma, SSCLK and REFCLK	2.0			V
Output Low Voltage	V _{OL1}	I _{OL} =4 ma, SSCLK			0.4	V
Output Low Voltage	V _{OL2}	I _{OL} =10 ma, SSCLK			1.2	V
Power Supply Current	I _{DD2}	F _{IN} =32 MHz, no load		19.0	23.0	mA
Power Supply Current	I _{DD3}	$\overline{\text{PD}}$ = GND		150	250	uA



Parameter	Symbol	Conditions	Min.	Typ.	Max.	Units
Input Capacitance	C _{IN}			5		pF
clock output impedance				20		ohms
Internal pull-up resistor	R _{PU}	SEL		360		kΩ

AC Electrical Characteristics

Unless stated otherwise, VDD = 3.3 V ±10%, Ambient Temperature 0 to +70° C

Parameter	Symbol	Conditions	Min.	Typ.	Max.	Units
Input Clock Frequency			16		32	MHz
Output Clock Frequency			16		32	MHz
Clock Rise Time	trise1	SSCLK and REFCLK, 0.4 V to 2.4 V	2.0	3.0	4.0	ns
Clock Fall Time	tfall1	SSCLK and REFCLK, 0.4 V to 2.4 V	2.0	3.0	4.0	ns
Input Clock Duty Cycle		X ₁	20	50	80	%
Output Clock Duty Cycle		SSCLK and REFCLK @ 1.5V	45	50	55	%
Cycle-to-Cycle Jitter		SSCLK, Fin=21MHz, Fout=21MHz		250	350	ps
Cycle-to-Cycle Jitter		REFCLK, Fin=21MHz, Fout=21MHz		275	375	ps
EMI Peak Frequency Reduction				8 to 16		dB



Thermal Characteristics

Parameter	Symbol	Conditions	Min.	Typ.	Max.	Units
Thermal Resistance Junction to Ambient	θ_{JA}	Still air		110		$^{\circ}\text{C}/\text{W}$
	θ_{JA}	1 m/s air flow		100		$^{\circ}\text{C}/\text{W}$
	θ_{JA}	3 m/s air flow		80		$^{\circ}\text{C}/\text{W}$
Thermal Resistance Junction to Case	θ_{JC}			35		$^{\circ}\text{C}/\text{W}$

Marking Diagram

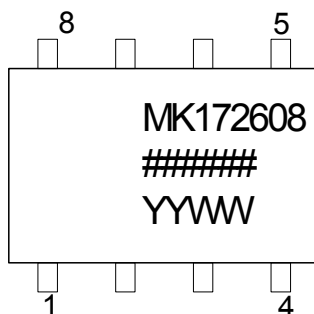

Notes:

1. ##### is the lot code.
2. YYWW is the last two digits of the year, and the week number that the part was assembled.

Marking Diagram (Pb free)

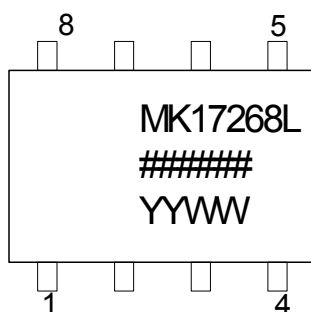

Notes:

1. ##### is the lot code.
2. YYWW is the last two digits of the year, and the week number that the part was assembled.
3. "L" designates Pb (lead) free package.



Package Outline and Package Dimensions (8 pin SOIC, 150 Mil. Narrow Body)

Package dimensions are kept current with JEDEC Publication No. 95

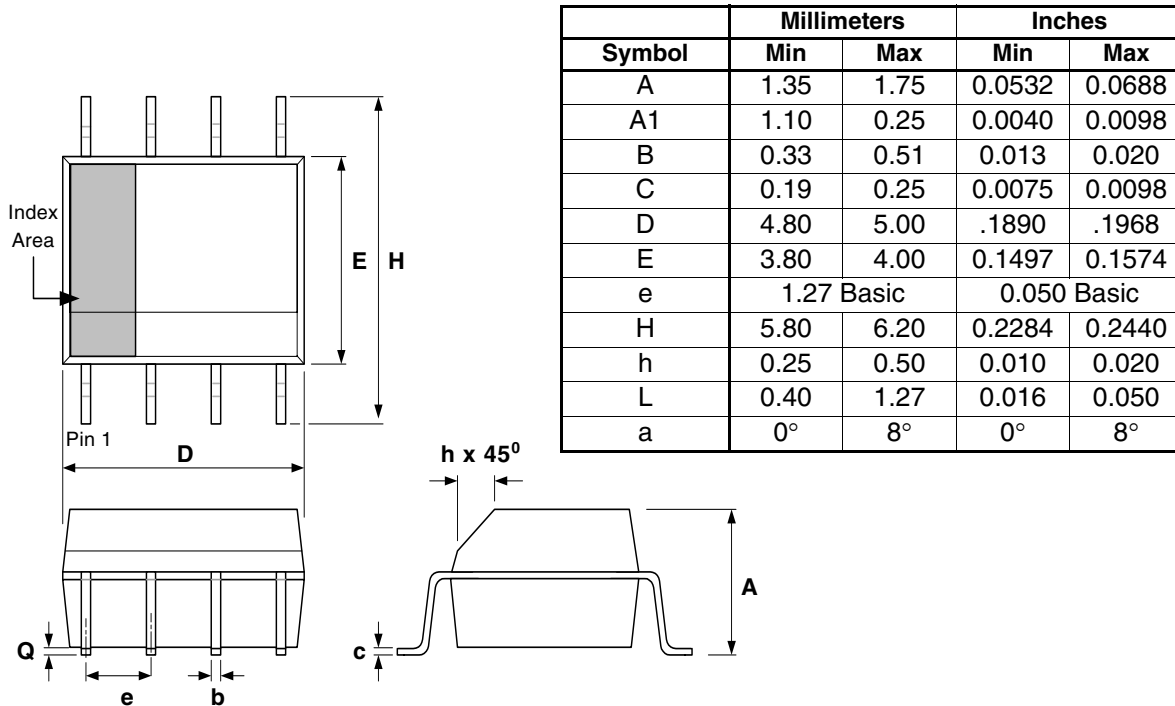

Ordering Information

Part / Order Number	Marking	Shipping Packaging	Package	Temperature
MK1726-08S	see previous page	Tubes	8-pin SOIC	0 to +70° C
MK1726-08STR	see previous page	Tape and Reel	8-pin SOIC	0 to +70° C
MK1726-08SLF	see previous page	Tubes	8-pin SOIC	0 to +70° C
MK1726-08SLFTR	see previous page	Tape and Reel	8-pin SOIC	0 to +70° C

“LF” designates Pb (lead) free package.

While the information presented herein has been checked for both accuracy and reliability, Integrated Circuit Systems (ICS) assumes no responsibility for either its use or for the infringement of any patents or other rights of third parties, which would result from its use. No other circuits, patents, or licenses are implied. This product is intended for use in normal commercial applications. Any other applications such as those requiring extended temperature range, high reliability, or other extraordinary environmental requirements are not recommended without additional processing by ICS. ICS reserves the right to change any circuitry or specifications without notice. ICS does not authorize or warrant any ICS product for use in life support devices or critical medical instruments.