

TV Sound Multiplexing Decoder

For the availability of this product, please contact the sales office.

Description

CXA1113AS is a bipolar IC designed as a decoder for TV sound multiplexing in Japan. Functions cover audio multiplex demodulation, electronic volume, muting, and tone control among others.

Features

- All adjustments are possible through I²C bus to enable automatic adjustment, including filter adjustment so far performed through volume.
- 2 systems of input pins: MPX IN (Audio multiplexing signal input pin). VCR IN (External signal input pin).
- 3 systems of output pins: VCR OUT (Audio multiplexing signal demodulation output pin). HP OUT (Audio multiplexing signal demodulation output pin with external signal output and electronic volume). LS OUT (Audio multiplexing signal demodulation output pin with external signal output, electronic volume, and tone control).

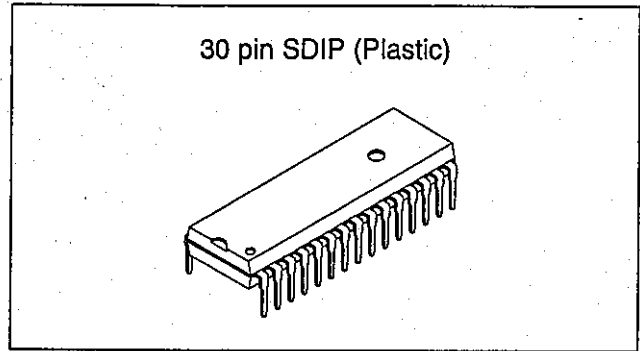

Output selection and others are performed by varying the contents of I²C bus register.

SDA: Serial Data MPX: Multiplex
SCL: Serial Clock VCR: Video Cassette Recorder
HP: Headphone LS: Loud speaker

Applications

TV and VCR television audio multiplex demodulation circuit for Japan.

Structure

Bipolar silicon monolithic IC.

Block Diagram

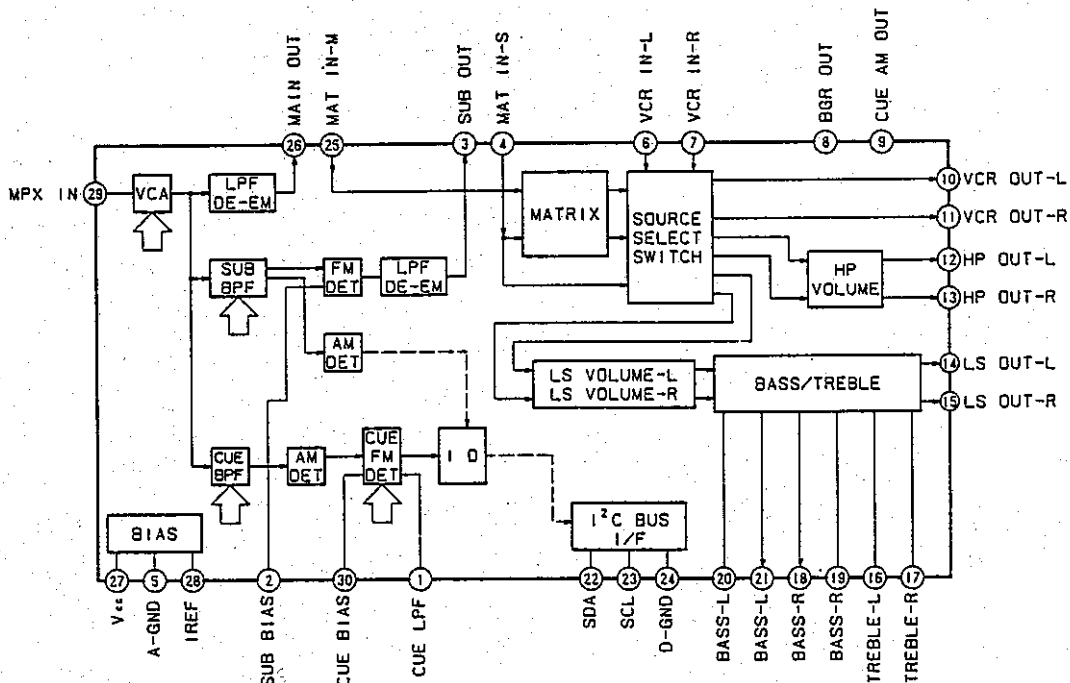

Sony reserves the right to change products and specifications without prior notice. This information does not convey any license by any implication or otherwise under any patents or other right. Application circuits shown, if any, are typical examples illustrating the operation of the devices. Sony cannot assume responsibility for any problems arising out of the use of these circuits.

Absolute Maximum Ratings (Ta=25°C)

• Supply voltage	Vcc	12	V
• Operating temperature	Topr	-20 to +75	°C
• Storage temperature	Tstg	-65 to +150	°C
• Allowable power dissipation	Pd	1.35	W

Recommended Operating Conditions

• Supply voltage	Vcc	8.5 to 9.5	V
------------------	-----	------------	---

Pin Configuration (Top View)

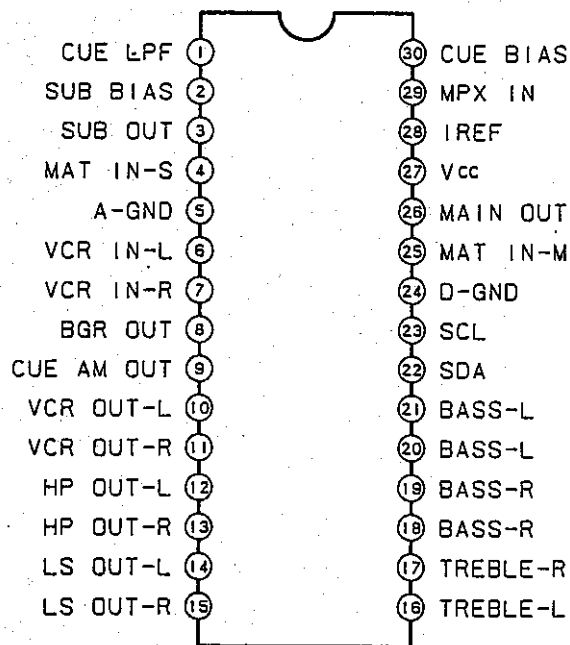

Pin Description and Equivalent Circuit

* Ta =25°C Vcc=9V

Pins No.	Symbol	*Terminal Voltage	Equivalent Circuit	Pin Description
1	CUE LPF	4.4V		<p>Connect an 1 µF capacitor between this pin and GND. The output of FM demodulated CUE signals to indicates whether the broadcasting is of the stereo or bilingual type.</p> <p>STEREO: Approx. 7V BILINGUAL: Approx. 2V MONAURAL: Approx. 4.5V</p>
2	SUB BIAS	4.4V		<p>SUB signal bias pin. Connect 1µF capacitor between this and GND.</p>
3	SUB OUT	3.7V		<p>SUB signal DE-emphasized output. For { STEREO: L-R signal BILINGUAL: SUB signal</p>
26	MAIN OUT	3.7V		<p>*MAIN signal DE-EM output.</p>
4	MAT IN-S	4.4V		<p>Input pin to the SUB signal matrix. Connect 10µF capacitor between this pin and SUB OUT (Pin 3).</p>
25	MAT IN-M	4.4V		<p>Input pin to the MAIN signal matrix. Connect 10µF capacitor between this pin and Pin 26.</p>
5	GND-A	—		Ground pin of Analog circuit block.
6	VCR IN-L	4.4V		<p>Left external input pin of sound processor.</p>
7	VCR IN-R	4.4V		<p>Right external input pin of sound processor.</p>

Pins No.	Symbol	Terminal Voltage	Equivalent Circuit	Pin Description
8	BGR OUT	4.4V		Connect the band gap reference output pin and 22 µF capacitor between this pin and GND. This capacitor serves to eliminate noise.
9	CUE AM OUT	2.9V		Connect 2.2 nF capacitor of CUE AM DET output pin 2.2 nF between this pin and GND.
10	VCR OUT-L	3.7V		TV audio output pin. (LEFT)
11	VCR-OUT-R	3.7V		TV audio output pin. (RIGHT)
12	HP OUT-L	3.7V		HEADPHONE output pin..(LEFT)
13	HP OUT-R	3.7V		HEADPHONE output pin (RIGHT)
14	LS OUT-L	3.7V		SPEAKER output pin. (LEFT)
15	LS OUT-R	3.7V		SPEAKER output pin. (RIGHT)
16	TREBLE-L	4.4V		Pin for TREBLE filter. Connect 3.9 nF capacitor between this pin and GND.
17	TREBLE-R	4.4V		Pin for TREBLE filter. Connect 3.9 nF capacitor between this pin and GND.
18	BASS-R	4.4V		Pin for BASS filter. Connect 47 nF capacitor between Pins 18 and 19 (RIGHT). As this value grows larger, the cut-off frequency moves to the low band side.
19	BASS-R	4.4V		
20	BASS-L	4.4V	The same circuit as for Pin 19.	Pin for BASS filter. Connect 47 nF capacitor between Pins 20 and 21 (LEFT). As this value grows larger, the cut-off frequency moves to the low band side.
21	BASS-L	4.4V	The same circuit as for Pin 18.	

Pins No.	Symbol	Terminal Voltage	Equivalent Circuit	Pin Description
22	SDA	—		SDA (Serial Data Line) of I ² C BUS standards. Threshold level is set to approx. 2.3 V. Open collector output.
23	SCL	—		SCL (Serial Clock Line) of I ² C BUS standards. Threshold level is set to approx. 2.3 V.
24	D-GND	—		GND of digital control part (I ² L).
27	Vcc	9V		Supply voltage pin.
28	IREF	4.4V		Pin that forms the inner reference current. Connect to GND via a 82kΩ resistance.
29	MPX IN	4.4V		Audio multiplexing signal input pin. (MPX input pin.)
30	CUE BIAS	3.1V		Connect to GND via 1µF capacitor when using CUE signal bias pin.

Pin Voltage External Test Circuit

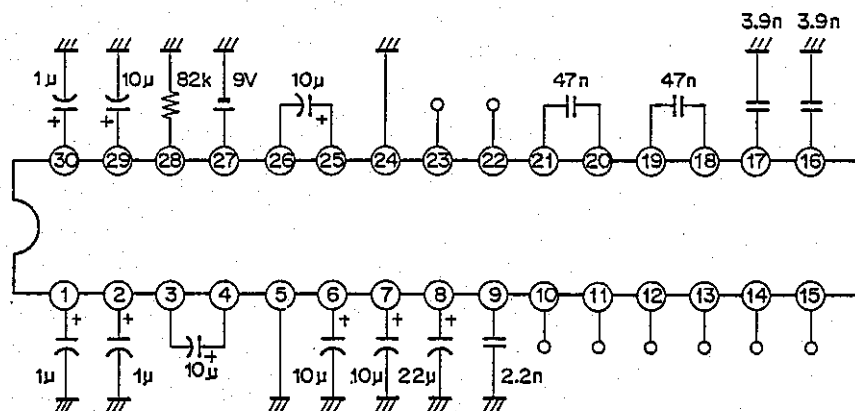

Representative Electrical Characteristics (Typ.)

Ta=25°C Vcc=9V VIN=500mVrms MAIN100%

Item		Typ.
Audio Multiplexing Decoder System	VCR OUT output (MAIN, SUB, 1 kHz 100%)	400 mVrms
	S/N (MAIN 100%, 1 kHz, VCR OUT)	73 dB
	S/N (SUB 100%, 1 kHz, VCR OUT)	64 dB
	Distortion (MAIN 100%, 1 kHz, VCR OUT)	0.1%
	Distortion (SUB 100%, 1 kHz, VCR OUT)	0.6%
	Distortion (STEREO 100%, 1 kHz, VCR OUT)	0.2%
	Crosstalk (MAIN→SUB, 1 kHz)	-57 dB
	Crosstalk (SUB→MAIN, 1 kHz)	-63 dB
	Cue signal sensitivity	-26 dB
	Sub carrier detection sensitivity	-16 dB
	Cue signal disturbance exclusion ability	-35dB
	DC offset between outputs	5 mV
Audio Processor System	Max. input signal (When tone control is flat).	2 Vrms
	Typ. input signal.	500 mVrms
	Tone control characteristics (BASS, TREBLE)	±10 dB
	Volume characteristics (2 dB STEP)	0 dB to -57 dB
	Mute characteristics	-85 dB
	Distortion (1 kHz, 500 mVrms input, volume -10 dB)	0.1%
	DC offset between outputs	5 mV

Electrical Characteristics

Setting Conditions

- Initial setting
- Adjustment
- Standard input signal (MPX IN input)
- Standard input signal (VCR IN input)

Corresponds to "Testing method (1) I²C bus register data initial setting."

Corresponds to Testing method(2) adjustment before testing.

Main 100% taken as 500 mVrms. (±1.5 dB)

Sub modulation 100%.

500mVrms. (BASS, TREBLE 2 Vrms maximum at flat response.)

No.	Item	Symbol	Conditions	Test contents	Testing filter	Test point	Switch set ON.	Min.	Typ.	Max.	Unit
1	Reference bias	V _{REF}	V _{CC} =9V, No signal input. I ² C bus register initial setting.	Pin voltage testing.		IREF (Pin 28)		—	4.45	—	V
2	Consumption current	I _{CC}	V _{CC} =9V, No signal input. I ² C bus register initial setting.	Testing of current flowing into pin.		V _{CC} (Pin 27)		26	38	50	mA
3	Supply voltage	V _{CC}	V _{CC} (Pin 27) voltage range.					8.5	9	11	V
4	Supply voltage range	V _{CC, opr}	Set to NO.3 V _{CC} voltage. Supply voltage permissible fluctuation range after pin adjustment. Do not let V _{CC} turn below 8.5 V.					-0.2	0	+0.2	V
Items for Audio Multiplex Decoder (VCR)											
5	SUB BPF (31.5kHz)	A _{2fH}	Input: MPX PIN (Pin 29) 31.5 kHz (300 mVrms)	Test SUB BPF output level. Refer to input level.		SUB BIAS (Pin 2)	SW0 SW2 SW29	—	-1.4	—	dB
6	SUB BPE (15.7kHz)	A _{fH}	Input: MPX IN 15.7 kHz (300 mVrms)	Test SUB BPF output level. Refer to No. 5.		SUB BIAS	SW0 SW2 SW29	—	-9	—	dB
7	SUB BPF (47.2kHz)	A _{3fH}	Input: MPX IN 47.2 kHz (300 mVrms)	Test SUB BPF output level. Refer to No. 5.		SUB BIAS	SW0 SW2 SW29	—	-5	—	dB
8	SUB BPF (55.1kHz)	A _{3.5fH}	Input: MPX IN 55.1 kHz (300 mVrms)	Test SUB BPF output level. Refer to No. 5.		SUB BIAS	SW0 SW2 SW29	—	-31	—	dB
9	Main Max. output level	V _{MAIN-MAX}	Input: MPX IN BIL 1 kHz (Main/Sub) "SEPARATION"=3FH.	Test Max Gain of VCA. Main output. Refer to 452 mVrms.	LPF	VCR OUT -L (Pin 10)	SW29	2.0	3.2	4.5	dB
10	Main Min. output level	V _{MAIN-MIN}	Input: MPX IN BIL 1 kHz (Main/Sub) "SEPARATION"=0H.	Test Min Gain of VCA. Main output. Refer to 452 mVrms.	LPF	VCR OUT -L	SW29	-5.5	-4.5	-3.0	dB
11	Sub output level	V _{SUB}	Input: MPX IN BIL 1 kHz (Main/Sub) "SEPARATION"=1FH.	Test SUB demodulation level. 0 dBm=0.775 Vrms.	LPF	VCR OUT -R (Pin 11)	SW29	-7.0	-5.3	-3.5	dBm
12	Stereo separation	SE _{TV}	Input: MPX IN-STE 1 kHz Rch "SEPARATION"=Adjust Data	Ratio of VCR OUT -R and -L levels after stereo separation adjustment.	BPF	VCR OUT -L, -R (Pins 10, 11)	SW29	34	41	—	dB
13	Main output level	V _{MAIN}	Input: MPX IN BIL 1 kHz (Main/Sub) After stereo separation adjustment	Test Main output level.	LPF	VCR OUT -L	SW29	-7.5	-5.7	-3.5	dBm
14	Main-Sub Output level difference	ΔV _{VCR}	Ratio of No. 11 and 13 test results	Ratio of Main output and Sub output levels.				-1	0	+1	dB
15	DC offset	ΔV _{VCR-DC}	Input: MPX IN Sub carrier + BIL-Q Sub carrier + STE-Q	Test DC voltage fluctuations of both VCR R and VCR L outputs switching to monaural, stereo, and bilingual modes. Mute taken as reference.	LPF	VCR OUT -L, -R	SW29	-40		+40	mV
16	Main frequency characteristics	AV _{VCR+M}	Input: MPX IN BIL 10 kHz (Main/Sub)	Test Main output level frequency characteristics. Refer to No. 13.	LPF	VCR OUT -L	SW29	-16.5	-14.1	-12.0	dB
17	Sub frequency characteristics	AV _{VCR+S}	Input: MPX IN BIL 10 kHz (Main/Sub)	Sub output level frequency characteristics. Refer to No. 11.	LPF	VCR OUT -R	SW29	-18.5	-15.5	-13.0	dB

No.	Item	Symbol	Conditions	Test contents	Testing filter	Test point	Switch set ON.	Min.	Typ.	Max.	Unit
18	Main distortion	THDVCR-M	Input: MPX IN BIL 1 kHz (Main/ Sub)	Test Main output distortion.	LPF	VCR OUT -R	SW29	—	0.1	1.1	%
19	Sub distortion	THDVCR-S	Input: MPX IN BIL 1 kHz (Main/ Sub)	Test Sub output distortion.	LPF	VCR OUT -L	SW29	—	0.6	2.5	%
20	STE distortion	THDVCR-STE	Input: MPX IN STE 1 kHz Rch	Test stereo Rch output distortion.	LPF	VCR OUT -R	SW29	—	0.2	2.0	%
21	Main noise level	SNVCR-M	Input: MPX IN (Pin 29) Sub carrier + BIL-Q	Main output test noise. Refer to No. 13.	LPF	VCR OUT-L (Pin 10)	SW29	—	-73	-64	dB
22	Sub noise level	SNVCR-S	Input: MPX IN Sub carrier + BIL-Q	Sub output test noise. Refer to No. 11.	LPF	VCR OUT-R (Pin 11)	SW29	—	-64	-55	dB
23	Cross talk Main → Sub	CRVCR-MS	Input: MPX IN BIL 1kHz (Main)	Crosstalk test from Main to Sub. Refer to No. 13.	BPF	VCR OUT-R	SW29	—	-57	-53	dB
24	Cross talk Sub → Main	CRVCR-SM	Input: MPX IN BIL 1 kHz (Sub)	Crosstalk test from Sub to Main. Refer to No.13.	BPF	VCR OUT-L	SW29	—	-63	-54	dB
25	Sub remaining carrier	CLEAK-SUB	Input: MPX IN Sub carrier + BIL-Q	Test 4fH (64 kHz) components output from Sub FM demodulator.		VCR OUT-R	SW29	—	60	130	mVp-p
26	Cue signal sensitivity	So	Input: MPX IN Sub carrier + BIL-Q Damp Cue signal level	Test Cue signal level unable to discriminate Cue signal. Standard level taken as reference.		I ² C data "BIL"	SW29	—	-26	-14	dB
27	Elimination of cue signal interference	AVo	Input: MPX IN BIL 1 kHz (Main) 1 kHz (Sub)	Leakage to Cue discrimination system of Sub component. Output level during BIL 1 kHz (Main) input taken as reference.	LPF	CUE BIAS (Pin 30)	SW29 SW30	—	-35	-20	dB
28	Sub carrier detection sensitivity	Ssub	Input: MPX IN Sub carrier + BIL-Q Damp Sub carrier level	Test level of Sub carrier that turns to MONO mode during BIL mode. Typical value taken as reference.		I ² C data "BIL"	SW29	—	-16	-10	dB
29	Output level during MUTE	VVCR-MUT	Input: MPX IN BIL 1 kHz (Main/Sub) VCR OUT Mute ON	Test output level when VCR OUT output is muted. Refer to No. 11 and 13.	BPF	VCR OUT -L, -R (Pins 10, 11)	SW29	—	—	-80	dB
Sound Processor Items (HP, LS)											
30	Sound Pro. Output level	VSP	Input VCR IN -L, -R (Pins 6, 7) 1 kHz 500 mVrms Max. VOLUME, BASS TRE with flat characteristics.	HP LS OUT output level is tested when external audio input is selected. Refer to input level.	LPF	HP, LS OUT -L, -R (Pins 12to15)	SW6 SW7	-1.2	-0.4	+0.2	dB
31	DC offset (HP, LS OUT)	ΔVSP-DC	No signal input. Vary BASS, TRE., VOL.	Test DC motor drive when switching from BASS, TRE., to VOL. during external audio input. Mute period is taken as reference.	LPF	HP, LS OUT -L, -R		-40		+40	mV
32	Sound Pro. Output level during Mute	VSP-MUT	Input: VCR IN -L, -R 1 kHz 500 mVrms HP, LS at mute ("HP VOL."=0)	Test output level when HP, LS OUT is muted. Refer to No. 30.	BPF	HP, LS OUT -L, -R	SW6 SW7	—	—	-80	dB
33	Distortion Sound Pro.	THD _{SP}	Input: VCR IN -L, -R 1 kHz 500 mVrms "LS VOL."=1AH, "HP VOL."=1AH	Test HP, LS OUT distortion. HP, LS OUT is at -10 dB level to Max. VOL.	LPF	HP, LS OUT -L, -R	SW6 SW7	—	0.1	0.5	%
34	Sound Pro. Noise level	SN _{SP}	No signal input. Max. VOLUME, BASS TRE with flat characteristics.	Test HP, LS OUT noise level. Refer to No. 30.	LPF	HP, LS OUT -L, -R		—	—	-74	dB
35	VOLUME Min. value	VOL _{MIN}	Input: VCR IN -L, -R 1 kHz 500 mVrms Min. VOL. ("HP VOL, LS VOL."=1H.)	Test output level (Volume of HP, LS OUT) when level is smallest. Refer to No. 30.	BPF	HP, LS OUT -L, -R	SW6 SW7	—	-57	-54	dB
36	BASS MAX	AB-MAX	Input: VCR IN -L, -R 100 Hz 500 mVrms Max. VOL. "BASS"=5H.	Test output level (BASS of LS OUT) when level is largest. Refer to No. 30.	LPF	LS OUT -L, -R (Pins 14, 15)	SW6 SW7	8.0	9.1	10.0	dB

No.	Item	Symbol	Conditions	Test contents	Testing filter	Test point	Switch set ON.	Min.	Typ.	Max.	Unit
37	BASS MIN	AB-MIN	Input: VCR IN -L, -R 100 Hz 500 mVrms Max. VOL. "BASS"=BH.	Test output level (BASS of LS OUT) when level is smallest. Refer to No. 30.	LPF	LS OUT -L, -R	SW6 SW7	-10.1	-9.1	-8.1	dB
38	TREBLE MAX	AT-MAX	Input: VCR IN -L, -R 10 kHz 500 mVrms Max. VOL. "TREBLE"=5H	Test output level (TRE. of LS OUT) when level is largest. Refer to No. 30.	LPF	LS OUT -L, -R	SW6 SW7	7.6	8.6	9.6	dB
39	TREBLE MIN	AT-MIN	Input: VCR IN -L, -R 10 kHz 500 mVrms Max. VOL., "TREBLE"=5H	Test output level (TRE. of LS OUT) when level is smallest. Refer to No. 30.	LPF	LS OUT -L, -R	SW6 SW7	-9.9	-8.9	-7.9	dB
40	Cross talk INT→EXT	CR1→E	Input: MPX IN BIL 1 kHz (Main/Sub) Max. VOL., BASS TRE. with flat characteristics.	Test MPX signal cross talk during selecting external signal selection. Refer to No. 30.	BPF	HP, LS OUT -L, -R	SW6 SW7	—	—	-80	dB
41	Cross talk EXT→INT	CR2→I	Input: VCR IN -L, -R 1 kHz 500 mVrms "HPS, LSS"=2H.	Test cross talk of external signal during MPX signal selection. Refer to No. 13.	BPF	HP, LS OUT -L, -R	SW6 SW7	—	-66	-62	dB
42	Cross talk L→R	CR3→R	Input: VCR IN -L 1 kHz 500 mVrms "HPS, LSS"=4H.	Test cross talk to R during L external signal input. Refer to No. 30.	BPF	HP, LS OUT -L (Pins 12, 14)	SW6	—	—	-80	dB

I²C Bus Items (SDA, SCL)

No.	Item	Symbol	Min.	Typ.	Max.	Unit
43	High level input voltage	V _{IH}	3.0	—	5.0	V
44	Low level input voltage	V _{IL}	0	—	1.5	V
45	High level input current	I _{IH}	—	—	10	μA
46	Low level input current	I _{IL}	—	—	10	μA
47	During low level output voltage SDA (Pin 22) 3 mA inflow	V _{OL}	0	—	0.4	V
48	Maximum inflow current	I _{OL}	3	—	—	mA
49	Input capacity	C _i	—	—	10	pF
50	Maximum clock frequency	f _{SCL}	0	—	100	kHz
51	Data change minimum waiting time	T _{BUF}	4.7	—	—	μs
52	Minimum waiting time at start of data transfer	t _{HD:STA}	4.0	—	—	μs
53	Low level clock pulse width	t _{LOW}	4.7	—	—	μs
54	High level clock pulse width	t _{HIGH}	4.0	—	—	μs
55	Minimum waiting time for start preparation	t _{SU:STA}	4.7	—	—	μs
56	Minimum data hold time	t _{HD:DAT}	5	—	—	μs
57	Minimum data preparation time	t _{SU:DAT}	250	—	—	ns
58	Rise time	t _R	—	—	1	μs
59	Fall time	t _F	—	—	300	ns
60	Minimum waiting time for stop preparation	t _{SU:STO}	4.7	—	—	μs

I²C bus load conditions: Pull up resistor 4 kΩ (Connect to +5 V)
Load capacity 200pF (Connect to GND)

I²C Bus Control Signal

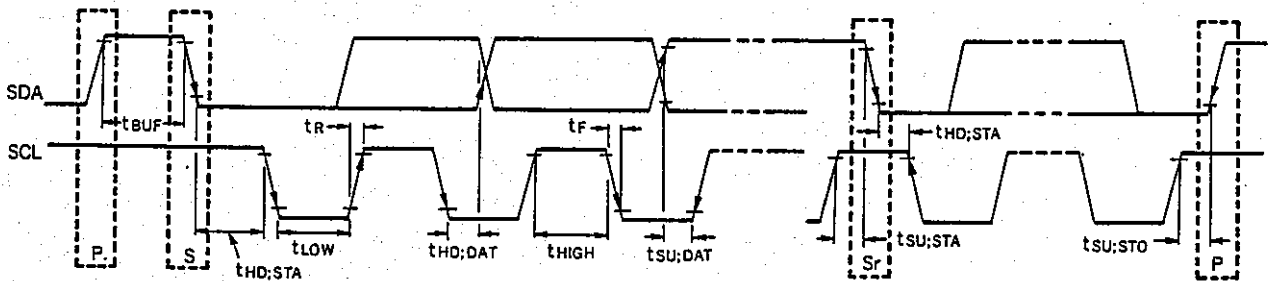

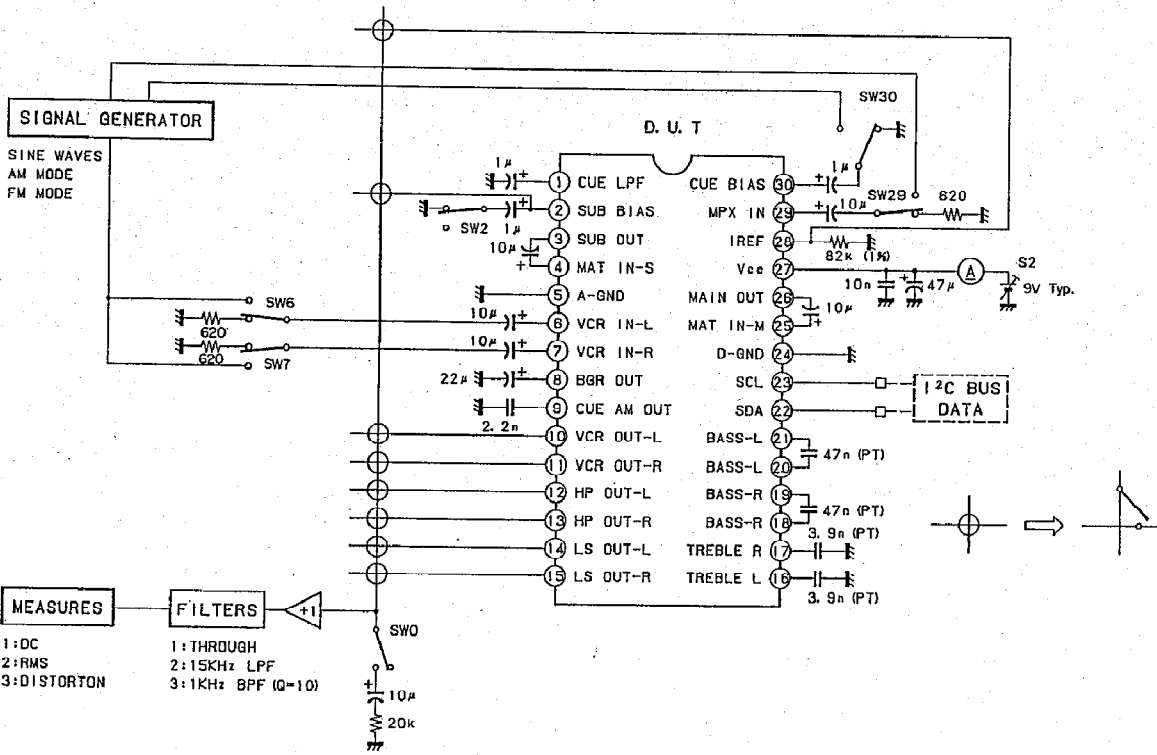

Test Methods

(1) I²C bus register data initial setting

Register	Data	Description	Standard value setting for electrical characteristics test	
			Audio multiplex decoder (VCR)	Sound processor system (HP,LS)
SUB VCO FILTER	1FH	} Center point	} Adjustment point	} Adjustment point
CUE FILTER	1FH			
CUE VCO	3FH			
SEPARATION	1FH	} Maximum value (0dB)	} Maximum value	} Maximum value (0 dB)
LS VOLUME-L	1FH			
LS VOLUME-R	1FH			
HP VOLUME	1FH	} Center point (Flat response)	} Center point	} Center point
BASS	0H			
TREBLE	0H			
LSS (LSS2,1,0)	2H	} Monaural ⇒ Main	} 2H.	} 4H (5H, 6H)
HPS (HPS2,1,0)	2H			
VCRS (VCRS1,0)	2H	} Bilingual ⇒ Main → L, Sub → R	} Mute cancel	} 2H
MUTVCR	1H			
MUTLS	1H	} Compulsory monaural mode cancel	} 1H Mute cancel	
FMONO	1H			} Ordinary mode
TEST (TEST1,0)	0H			

(2) Pre-test adjustment

	Adjustment item	Control data	Test data	Input pin	Signal-source	Test mode establishment setting (hexadecimal)
1.	SUB VCO & SUB FILTER	"SUB VCO FILTER"	"SUB FA"	MPX IN (Pin 29)	55.1 kHz 300 mVrms	1 Filter adjustment mode
2.	CUE FILTER	"CUE FILTER"	"CUE FA"	MPX IN	40.0 kHz 300 mVrms	1
3.	CUE VCO	"CUE VCO"	"CUE VH" "CUE VL"	MPX IN CEU BIAS (Pin 30)	31.5 kHz 300 mVrms 952.5 Hz 300 mVrms	0 Ordinary mode
4.	SEPARATION	"SEPARATION"	VCR OUT-L (Pin 10)	MPX IN	MPX signal Stereo Rch mode 1 kHz 100%MOD	0

Adjustment items 1 and 2: Adjust by varying control data (I²C Bus data) so that testing data (I²C Bus data) turns to 0. The data row center where 0 is continuous at the test data is the adjustment value.

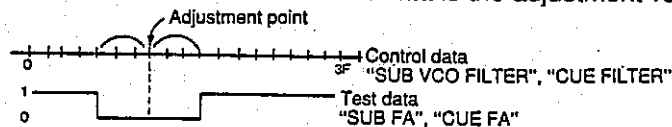

Adjustment item 3: Adjust measuring data to 0 by changing control data.

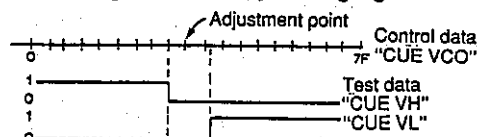

It is also possible to adjust this decoder by grounding CUE BIAS pin through a capacitor. Input 952.5 Hz 60% AM (carrier 55.1 kHz) 113 mVp-p, 31.5 kHz 300 mVrms into MPX IN pin.

Adjustment item 4: Input MPX signal stereo Rch (Lch) mode so as to turn 1 kHz components of VCR OUT-L (R) to a minimum.

(3) Input signal source

100 Hz, 1 kHz, 10 kHz (500 mVrms)

952.5 Hz, 15.7 kHz, 31.5 kHz, 40 kHz, 47.2 kHz, 55.1 kHz (300 mVrms)

BIL 1 kHz (Main/Sub) : 1 kHz (500 mVrms), FM1 kHz (31.5 kHz \pm 10 kHz, 300 mVrms), AM 922.5 Hz (For carrier 55.07 kHz, 60% MOD, 113 mVp-p)

STE 1 kHz Rch : 1 kHz 20 μ s delay (250 mVrms), FM 1 kHz (*31.5 kHz \pm 5 kHz, 400 mVrms), AM 982.5 Hz (For carrier 55.07 kHz, 60% MOD, 113 mVp-p)

BIL 10 kHz (Main/Sub) : 10 kHz (500 mVrms), FM10 kHz (31.5 kHz \pm 10 kHz, 300 mVrms), AM 922.5 Hz (For carrier 55.07 kHz, 60% MOD, 113 mVp-p)

BIL 1 kHz (Main) : 1 kHz (500 mVrms), 31.5 kHz (300 mVrms), AM 922.5 Hz (For carrier 55.07 kHz, 60% MOD, 113 mVp-p)

BIL 1 kHz (Sub) : FM 1 kHz (31.5 kHz \pm 10 kHz, 300 mVrms), AM 922.5 Hz (For carrier 55.07 kHz, 60% MOD, 113 mVp-p)

1 kHz (Sub) : FM1 kHz (31.5 kHz \pm 10 kHz, 300 mVrms)

Sub for carrier + BIL-Q : 31.5 kHz (300 mVrms)
AM 922.5 Hz (For carrier 55.07 kHz, 60% MOD, 113 mVp-p)

Sub for carrier + STE-Q : 31.5 kHz (400 mVrms)
AM 982.5 Hz (For carrier 55.07 kHz, 60% MOD, 113 mVp-p)

Note) For testing the modulation level of the Main and Sub signals is set to a standard 100%.

* Begin from reversed phase.

Operation

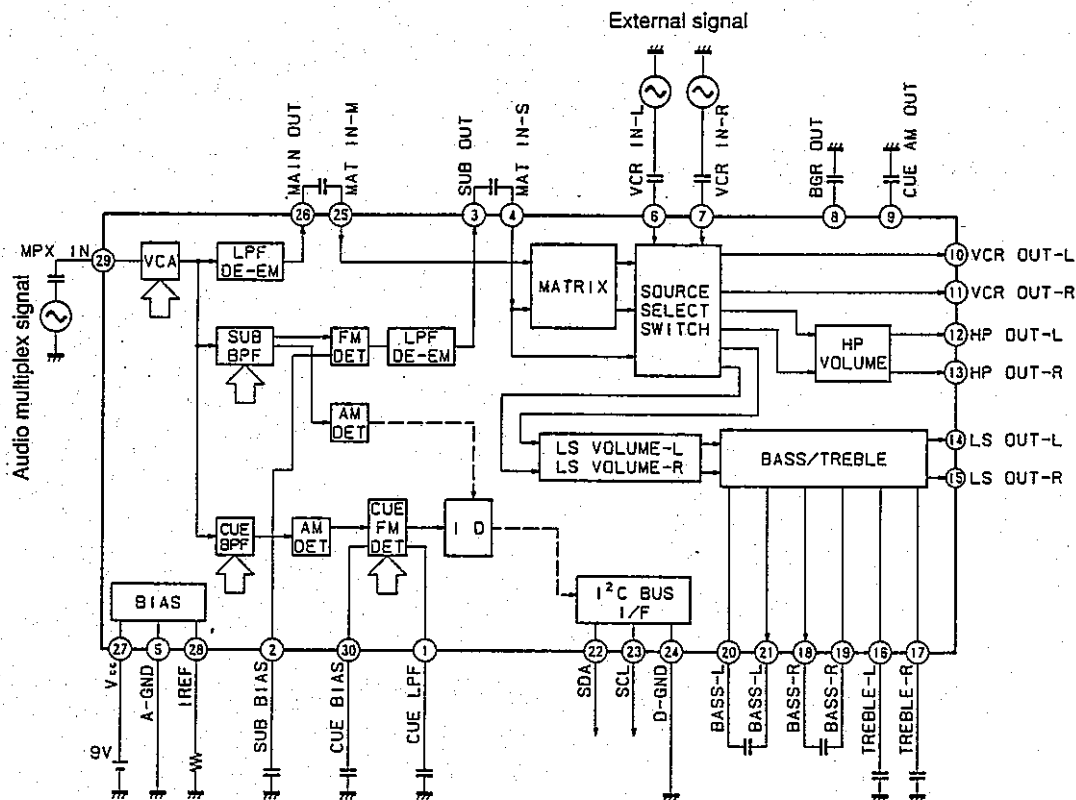

(1) Main system

Audio multiplex signal input to MPX IN (Pin 29) is amplified at "VCA". (Execute initial adjustment to obtain stereo separation. ± 3 dB). Signals passed through "LPF, DE-EM" (2.1 kHz and 15 kHz low pass filters) are turned into Main (L+R) signals only by means of filter characteristics and input to matrix circuit.

(2) Sub system

Audio multiplex signals input to MPX IN (Pin 29) pass through "SUB BPF" (band pass filter that extracts component in the vicinity of 2 MHz or 31.5 kHz ± 10 kHz) via "VCA".
 Extracted Sub signals picked are demodulated at the following "FMDET" (FM demodulator) because of their FM modulating waves. After demodulation, SUB (L-R) signals are output from LPF, DE-EM similarly as Main (L+R) signals.

(3) Cue system

Audio multiplex signals input to MPX IN (Pin 29) pass through "CUE BPF" (band pass filter that extracts discriminating signals from 3.5 MHz that is, 55.1 kHz stereo or bilingual modes) via VCA.
 Extracted CUE signals are detected as envelope components at the following AMDET (AM detector) because of their AM modulating waves. From the detected signals, stereo (982.5 Hz) and bilingual (922.5 Hz) have to be discriminated. "CUE FM DET" (FM demodulator) is used to discriminate by converting into DC voltage. (At Pin 1, CUE LPF stands at 7 V for stereo mode and 2 V for bilingual. For no-signal and monaural broadcasting, it is at 4.5 V.)
 "I.D." (discrimination circuit) is operated through this pin voltage and the discrimination results are transmitted to "I²C Bus I/F" (I²C Bus interface circuit.) SUB detection signals are input to I.D. block from SUB system. When there are not SUB signals, I.D. operates similarly as for no signal or monaural broadcast. (This is to prevent noise signals from causing misoperation of the discrimination system when there is no SUB signal.)

(4) Matrix, VCR, HP, LS systems

Signals input to "MATRIX" (L+R, L-R, MAIN, SUB) become the respective outputs of L, R, MAIN, and SUB signals according to BUS data and the presence or absence of CUE signals. "Source Select Switch" selects as input signals input to VCR IN-L, R (Pins 6, 7) and "MATRIX" output signals by means of BUS data. It distributes them among Pins 10 through 15. (See Source Select table for various controls (5) P. 17.)

- At VCR, "MATRIX" output, that is the demodulated output of audio multiplex signals, is output.
- At HP, the demodulated output of audio multiplex signals and input signals of VCR IN-L, R (Pins 6 and 7) are output. There is also electronic volume. (0 dB to -60 dB, 2 dB STEP)
- At LS in addition to HP functions, BASS TREBLE tone control functions are available. (± 10 dB, 2 dB STEP)

(5) Others

"BIAS" is for bias circuit. It supplies reference voltage and reference current to other blocks. The current flowing into the resistor 82 k Ω 1% connected between IREF (Pin 28) and GND is the reference current. Accordingly, usage of a resistor with any value other than 82 k Ω will not realize this IC's characteristics. Use a resistor with a temperature coefficient of ± 30 ppm/ $^{\circ}$ C. All registers are reset to 0 at Power ON. Keep supply voltage above 8.5 V. Under 8.5 V, the IC will not operate.

An outline CXA1113AS system

This IC is for I²C Bus audio multiplex demodulation by Japan standards. Through the 2 Bus lines SDA and SCL, it executes filter adjustment and all sorts of controls performed so far by means of the resistor volume. This IC incorporates a Bus decoder.

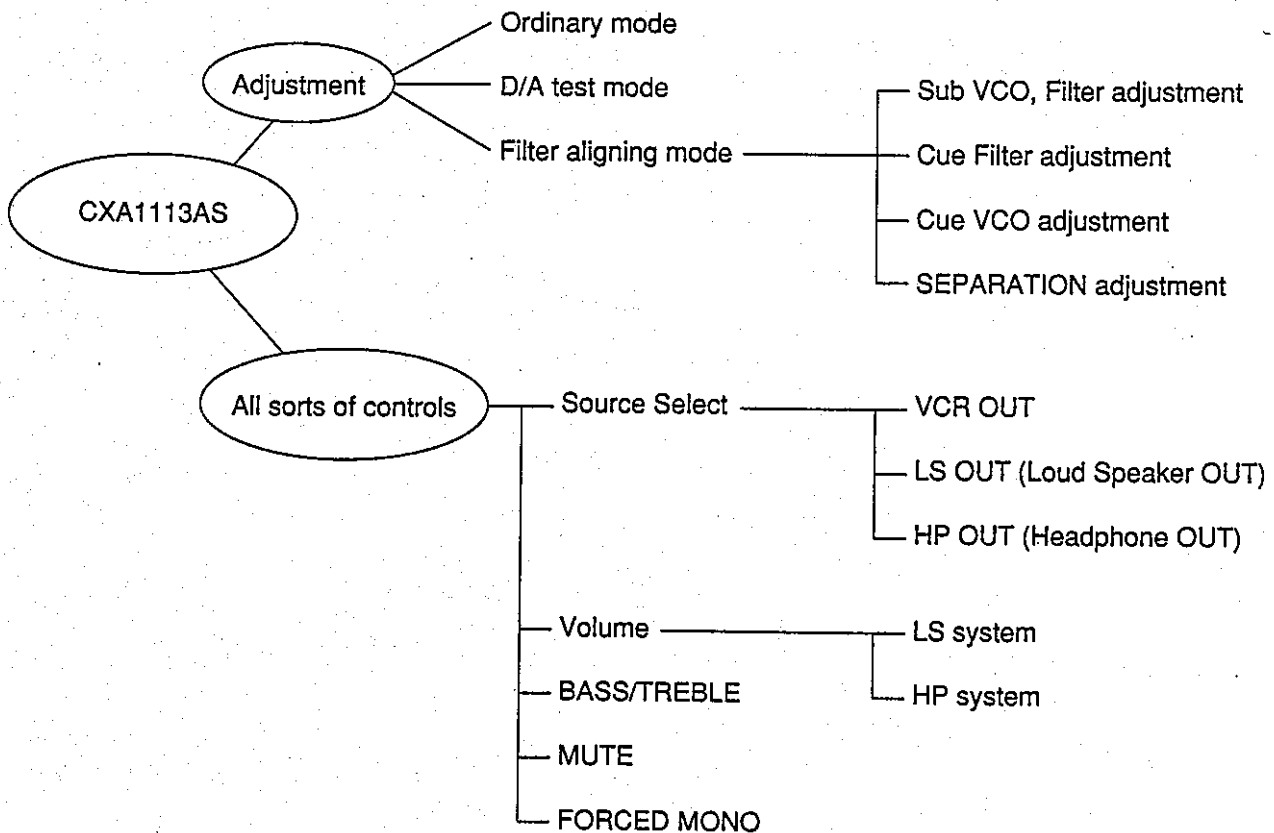

Protocol

<SLAVE ADDRESS>

80H SLAVE RECEIVER
 81H SLAVE TRANSMITTER

<REGISTER TABLE>

○ All registers are reset to 0 at the IC reset.
 ○ ** : Undetermined

[Control Register]

	BIT7	BIT6	BIT5	BIT4	BIT3	BIT2	BIT1	BIT0
..... 0000	SUB VCO FILTER (6)						TEST1	TEST0
..... 0001	CUE FILTER (6)						**	FMONO
..... 0010	CUE VCO (7)							**
..... 0011	SEPARATION (6)						**	**
..... 0100	LS VOLUME-L (5)					LSS2	LSS1	LSS0
..... 0101	LS VOLUME-R (5)					HPS2	HPS1	HPS0
..... 0110	HP VOLUME (5)					MUTVCR	VCRS1	VCRS0
..... 0111	BASS (4)				**	**	**	MUTLS
..... 1000	TREBLE (4)				**	**	**	**

[Status Register]

	BIT7	BIT6	BIT5	BIT4	BIT3	BIT2	BIT1	BIT0
1st byte	PONRES	ST	BIL	SUBFA	CUEFA	CUEVH	CUEVL	0
2nd byte	RET7	RET6	RET5	RET4	RET3	RET2	RET1	RET0

[Various controls]

MPX IN (Pin 29) is the input pin for audio multiplex signals.

As external input pins, VCR IN-L, R (Pins 6 and 7) are available. MPX IN standard input signal amplitude at MAIN 100 % is 500 mVrms. The standard for the external input pin is 500 mVrms. There are 3 types of output pins and each can be controlled independently.

- VCR OUT-L, R (Pins 10, 11) → Audio multiplex signals demodulation output.
- HP OUT-L, R (Pins 12, 13) → { Audio multiplex signals demodulation output.
External signal output.
Electronical volume.
- LS OUT-L, R (Pins 14, 15) → { Audio multiplex signals demodulation output.
External signal output.
Electronical volume and tone control.

(1) VOLUME

Volume is found in 2 spots LS and HP. At 2 dB/STEP MIN-60 dB and -80 dB at MUTE. (5 Bit)

- 0: MUTE
- 1: VOLUME MIN (-60 dB)
- 31: VOLUME MAX (0 dB)

Within the LS system, L, R can be independently controlled. Balance is obtained through L, R control.

(2) BASS/TREBLE

BASS/TREBLE are respectively controlled with 4 Bit. ±10 dB at 2 dB/STEP. To vary BASS/TREBLE cut off frequency vary the capacitor capacitance of Pins 16 to 21. By enlarging the capacitance value the cut off frequency moves to a lower band. (See Fig.)

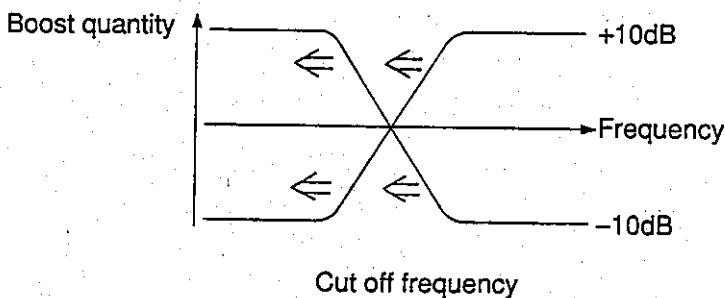

I ² C DATA	BASS/TREBLE boost quantity
0000	0 dB
0001	2 dB
0010	4 dB
0011	6 dB
0100	8 dB
0101	10 dB
1011	-10 dB
1100	-8 dB
1101	-6 dB
1110	-4 dB
1111	-2 dB

(3) MUTE

Mute applies at LS OUT and VCR OUT
MUTVCR, MUTHF (MUTHF is similar to LS OUT MUTE)

- 0: MUTE
- 1: MUTE cancel

Audio multiplex signals aren't output at Power ON unless Mute is cancelled MUTE.

(4) F MONO (FORCED MONO)

This mode forces monaural broadcast during stereophonic broadcasting.

- 0: FORCED MONO
- 1: FORCED MONO cancel

For this bit too, since it is at 0 with Power ON to receive stereophonic broadcasting, this F MONO has to be cancelled.

(5) SOURCE SELECT

LS output			HP output			VCR output		Broadcasting mode					
LSS2	LSS1	LSS0	HPS2	HPS1	HPS0	VCRS1	VCRS0	Monaural		Stereo		Bilingual	
								L	R	L	R	L	R
0	0	0	0	0	0	0	0	MAIN	MAIN	L[L+R]	R[L+R]	MAIN	MAIN
0	0	1	0	0	1	0	1	MAIN	MAIN	L[L+R]	R[L+R]	SUB	SUB
0	1	0	0	1	0	1	0	MAIN	MAIN	L[L+R]	R[L+R]	MAIN	SUB
1	0	0	1	0	0			E (L)	E (R)	←			←
1	0	1	1	0	1			E (L)	E (L)	←			←
1	1	0	1	1	0			E (R)	E (R)	←			←

E(L), E(R): External audio input

E(L): Indicates signal input to VCR IN-L

[In brackets when F MONO=0]

[Adjustment]

- Normally set "TEST"=ON.
- For D/A test mode "TEST"=2H. This mode is only used to check characteristics at the shipment inspection. It is not applied during IC mounting. In this mode D/A is output to IREF (Pin 28). Ranges vary from 2.6 V to 4.6 V with divisions 2⁶-1 or 2⁷-1. Min. control data is at 0H. At the Max. 3FH (6 Bit) and 7FH (7 Bit), it goes up to 4.6 V. The lowest voltage may be selected from the four D/As.
- Filter adjustment is performed at "TEST"=1. "SUB VCO FILTER" (6 Bit) used for SUB FILTER adjustment is turned to 55.1 kHz (3.5 fH Trap). "CUE FILTER" used for CUE FILTER adjustment is turned to 40 kHz (Trap). "SUB FA" is the adjustment point. The adjustment value is at the center of the data rows where 0 follows 0 at the test data of "CUE FA". Frequency variable range is approx. -20% (0H) + 20% (3 FH).
- "CUE VCO" (Cue system) adjustment is executed in the normal "TEST"=0H mode. Perform this adjustment after "SUB VCO FILTER" and "CUE FILTER". CUE VCO free run frequency is varied. The frequency variable range is within approx. -20% (0H), +20% (3FH). VCO free run frequency is set at 952.5 Hz, the center of two CUE signals, (922.5 Hz, 982.5 Hz). To this effect, input at 3.5 fH a 952.5 Hz AM wave, from MPX input instead of CUE signal. Adjust so as to obtain approx. 4.5 V at CUE LPF (Pin 1). ("CUE VH" = 0H, "CUE VL" = 0H) Or adjust through the input of 952.5 Hz (approx. 300 mVrms) to CUE BIAS (Pin 30). At that time, be sure to input approx. 31.5 kHz (approx. 300 mVrms) to MPX IN. (Without this input, SUB detection function does not operate performance versus Pin 1 control data "CUE VOC", slumps down and adjustment becomes impossible.
- Finally stereo separation is adjusted. This is performed in normal mode "TEST" = 0H. Input MPX signal Rch (Lch) mode and adjust so that the 1 kHz components of VCR OUT-L, (R) output reach a minimum value. As a method of adjustment vary the VCA (±3 dB amplifier) gain using the "SEPARATION" register. Variable range is within approx. -3 dB (0H), 0 dB (1 FH), +3 dB (3FH).
- Adjustment data is written into an external non volatile memory and then entered into the IC register after switching the IC ON.

Register Description

CONTROL REGISTERS

U: User control, A: Adjustment, S: Proper to TV set, T: Test, C: System control

Register	No. of bits	Classification	Description
SUB VCO FILTER	6	A	Adjustment of SUB VCO and SUB FILTER DE-EM LPF.
CUE FILTER	6	A	Adjustment of CUE BPF fo.
CUE VCO	7	A	Adjustment of CUE VCO fo.
SEPARATION	6	A	Adjustment of SEPARATION.
LS VOLUME-L	5	UA	LS (Lch) output level adjustment. 2dB/STEP. Mute at MIN. Performs LS output balance adjustment and balance user control.
LS VOLUME-R	5	UA	LS (Rch) output level adjustment. 2dB/STEP. Mute at MIN. Performs LS output balance adjustment and balance user control.
HP VOLUME	5	U	HP output level adjustment. 2 dB/STEP. Mute at MIN. No adjustment of HP output balance.
BASS	4	U	LS output tone control (BASS). 2 dB/STEP ±10 dB (MAX, MIN).
TREBLE	4	U	LS output tone control (TREBLE). 2 dB/STEP ±10 dB (MAX, MIN).
LSS2, 1, 0	3	U	LS output user control mode change.
HPS2, 1, 0	3	U	HP output user control mode change.
VCRS1, 0	2	U	VCR output user control mode change.
MUTVCR	1	S	VCR output mute ON/OFF.
MUTLS	1	US	LS output mute ON/OFF.
FMONO	1	U	Forced monaural mode ON/OFF. LS, HP, VCR, all outputs turn to monaural when switched on.
<TEST> TEST1, 0	2	T	DAC check mode and adjustment detection circuit enable/disable selection. This adjustment detect circuit selection is used during normal operation to prevent the detection circuit from operating.

STATUS REGISTERS

Register	No. of bits	Description
ST	1	Return 0 when the broadcasting mode is stereo.
BIL	1	Return 0 when the broadcasting mode is bilingual.
SUBFA	1	Used for SUB filter adjustment. 0 } Adjustment accomplished
CUEFA	1	Used for CUE filter adjustment. 0 }
CUEVH	1	Used for CUE filter VCO adjustment. 0 }
CUEVL	1	Used for CUE filter VCO adjustment. 0 } Adjustment accomplished at 0, 0.
<TEST> PONRES	1	Turns to 1 when Vcc goes below the threshold voltage. When I ² C controller has read this status, it is cleared to 0.
R E T7 , 0	8	For I ² C decoder test. Returns as it is 1 byte data written in Sub address 0 control register.

I²C Bus Signal

I²C Bus features 2 signals; SDA (Serial DATA) and SCL (Serial CLock). SDA is a double-way pin.

- This pin is therefore the output point of H, L and HIZ.

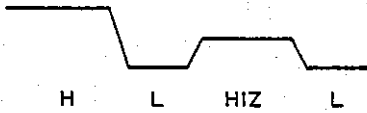

- I²C transfer begins with Start Condition and ends with Stop Condition.

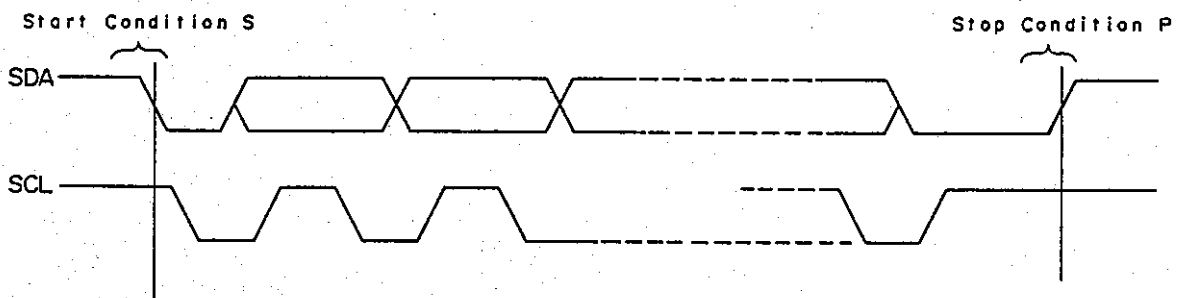

- I²C data Write (Write from I²C controller into IC)

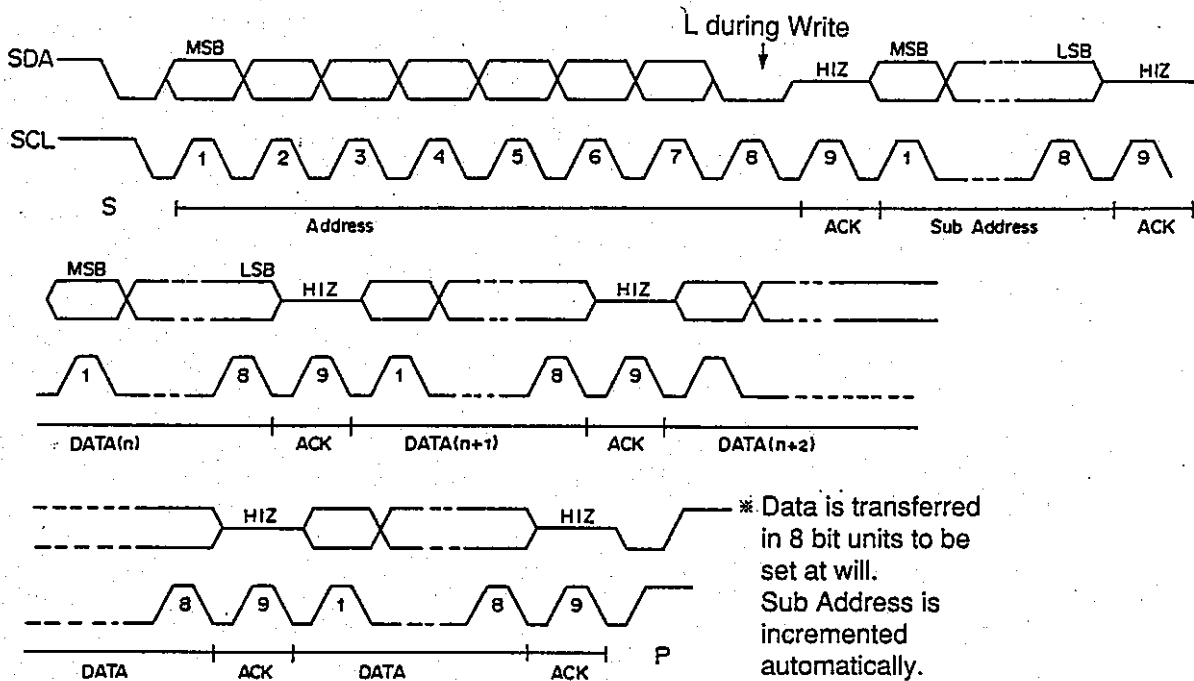

- Read of I²C data (Read from IC to I²C controller)

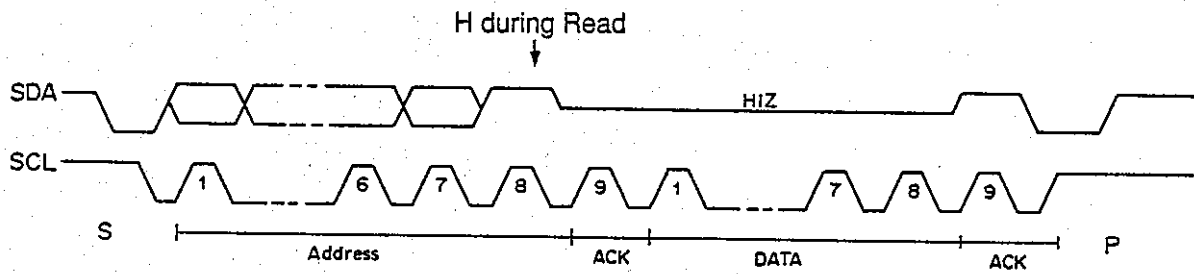

- Read timing

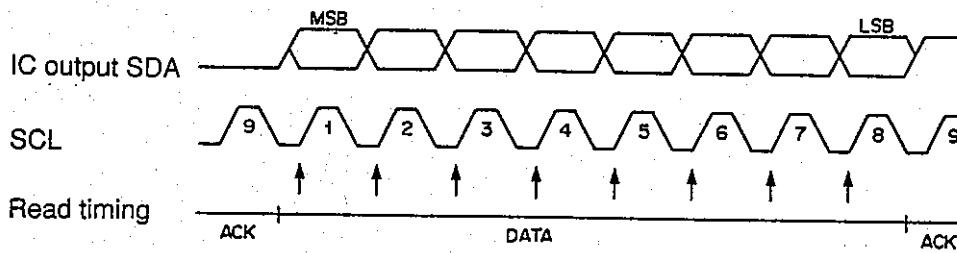

※ Data is read during SCL rising time.

Application Circuit

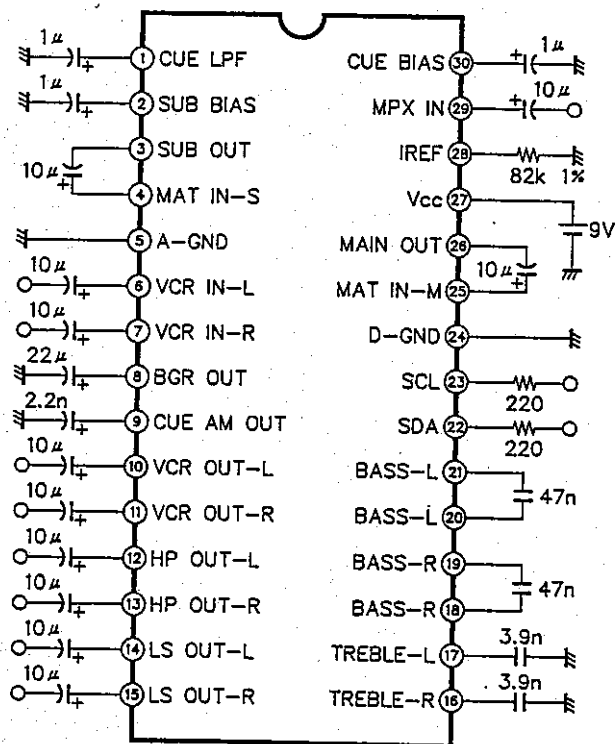

Band pass filter characteristics
SUB (BPF) Q (BPF)

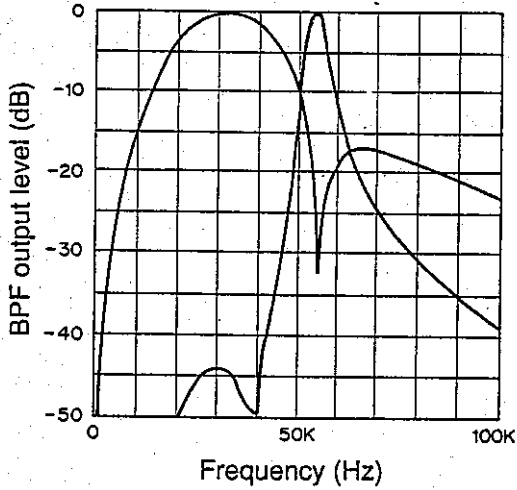

MAIN/SUB demodulation characteristics

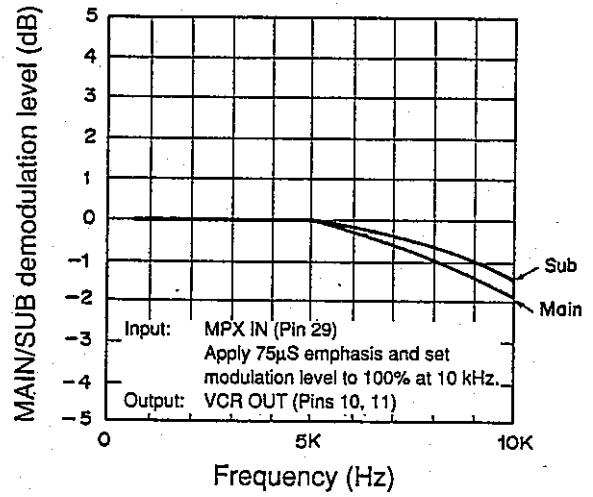

Volume characteristics

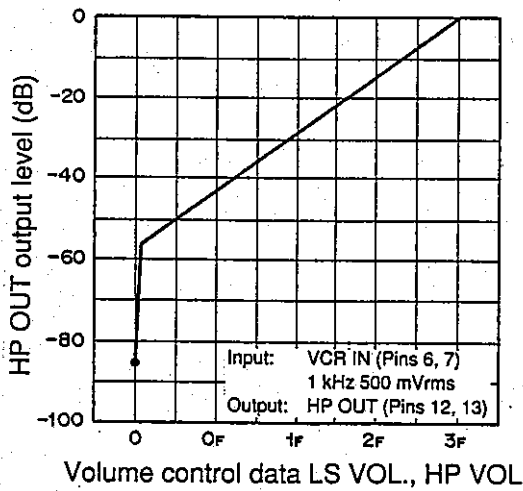

Distortion characteristics

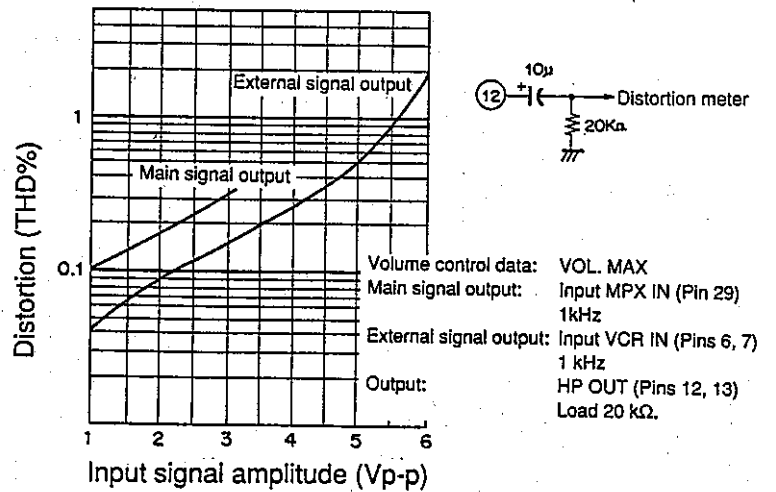

Stereo separation characteristics

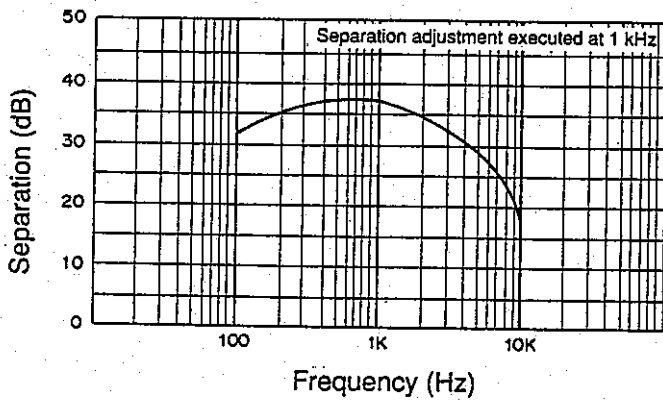

BASS-TREBLE characteristics

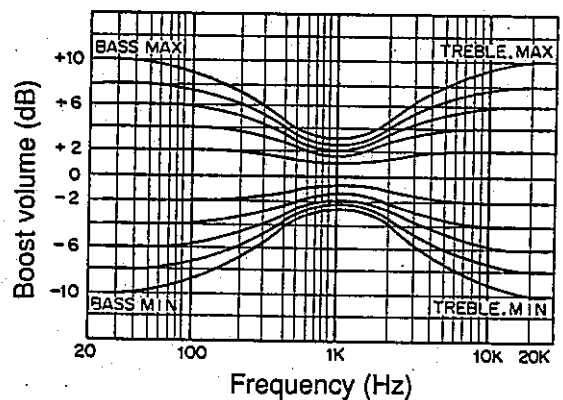

Input: VCR IN (Pins 6, 7)
500 mVrms
Output: LS OUT (Pins 14, 15)

FM detection characteristics (CUE signal)

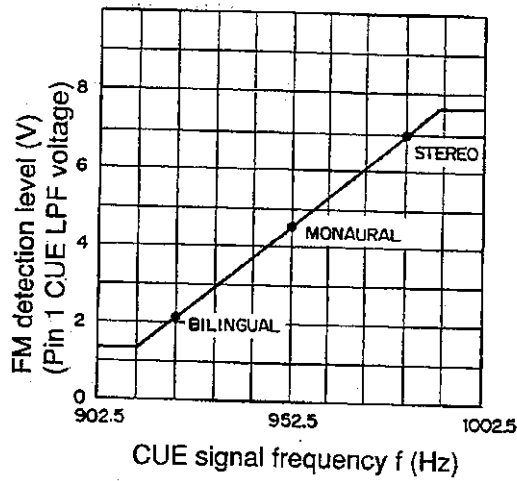

Audio multiplex mode switching characteristics

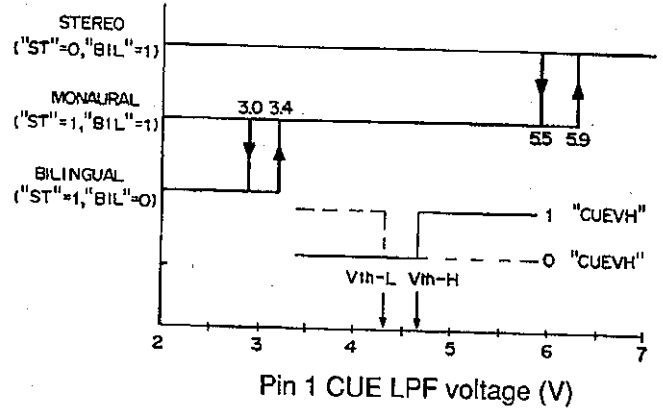

Purchase of Sony's IC components conveys a license under the Philips I²C Patent Rights to use these components in an I²C system, provided that the system conforms to the I²C Standard Specifications as defined by Philips.

Package Outline

Unit: mm

30PIN SDIP (PLASTIC)

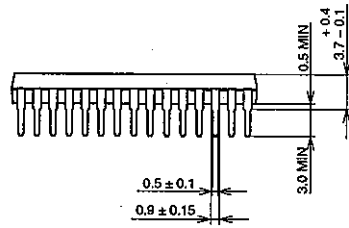
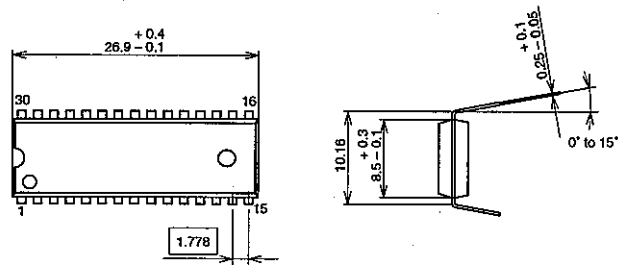

Two kinds of package surface:
 1. All mat surface type.
 2. All mirror surface type.

SONY CODE	SDIP-30P-01
EIAJ CODE	P-SDIP30-8.5x26.9-1.778
JEDEC CODE	

PACKAGE STRUCTURE

MOLDING COMPOUND	EPOXY RESIN
LEAD TREATMENT	SOLDER PLATING
LEAD MATERIAL	COPPER ALLOY
PACKAGE MASS	1.8g

30PIN SDIP (PLASTIC)

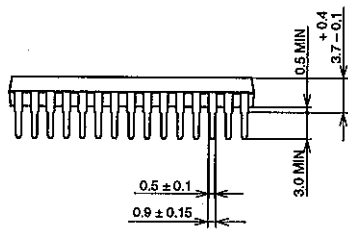
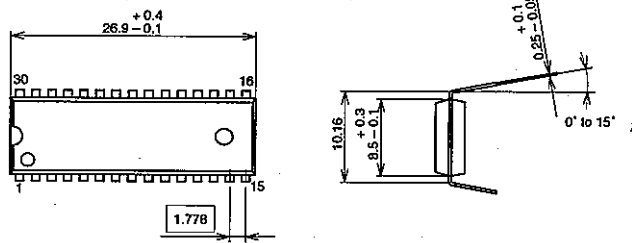

Two kinds of package surface:
 1. All mat surface type.
 2. All mirror surface type.

SONY CODE	SDIP-30P-01
EIAJ CODE	P-SDIP30-8.5x26.9-1.778
JEDEC CODE	

PACKAGE STRUCTURE

MOLDING COMPOUND	EPOXY RESIN
LEAD TREATMENT	SOLDER PLATING
LEAD MATERIAL	COPPER ALLOY
PACKAGE MASS	1.8g

LEAD PLATING SPECIFICATIONS

ITEM	SPEC.
LEAD MATERIAL	COPPER ALLOY
SOLDER COMPOSITION	Sn-Bi Bi:1-4wt%
PLATING THICKNESS	5-18µm