

FEATURES

- 10 - 500 MHz
- SPACE Application
- Hermetic Package
- Radiation Tolerant, 100 K Rad
- Surface Mount



MODEL NO.
CAT15067

GaAs 6 Section Attenuator

6 BIT

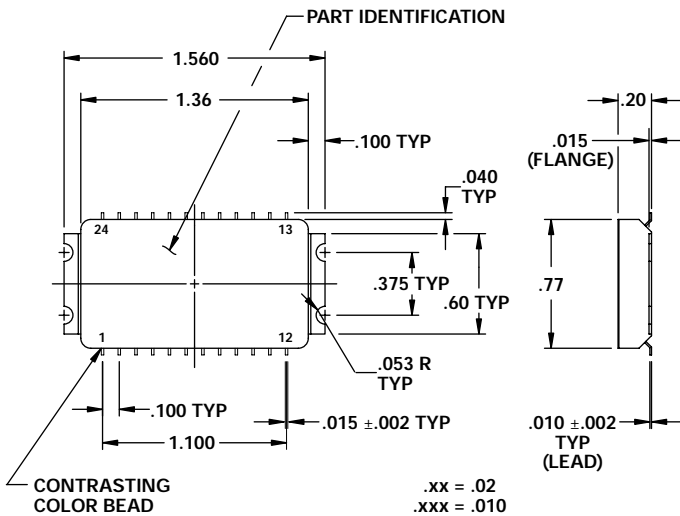
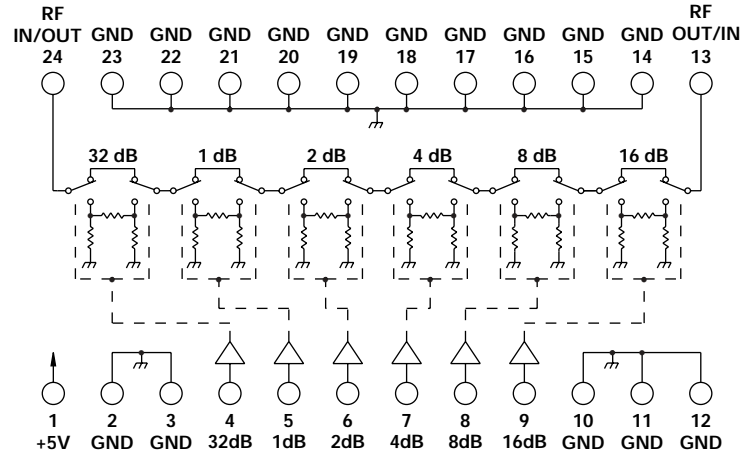

GUARANTEED PERFORMANCE

Parameter	Min	Typ	Max	Units	Conditions
Operating Frequency	10		500	MHz	
DC Current		0.02	5	mA	At +5 VDC Supply
Control Type		CMOS			6 Line Logic "0" = Thru Logic "1" = Attenuation
Control Current	High Low	1 1	±20 ±20	µA	3 - 5 Volts 0 - 0.5 Volts
Insertion Loss		5	6	dB	
Attenuation	LSB Range Accuracy Flatness	0	1 63 ±0.2	dB dB dB	1, 2, 4, 8, 16, 32 ± (0.25 dB + 2% of Atten Setting in dB)
VSWR		1.2/1	1.4/1		
Impedance		50		OHMS	
Switching Speed		34	50	nSec	50% Control Signal 90% / 10% RF
Transition (Rise/Fall) Time		15		nSec	10% / 90% or 90% / 10% RF
Switching (Video) Transients		280		mV	Peak Value
Intercept Points	2nd 3rd	+54 +34	+66 +44	dBm	70 / 50 MHz Inputs 35 / 50 MHz Inputs
RF Power	Operate No Damage		+12 +10 +23	dBm	0.1 dB Compression
Operating Temperature		0	+25	°C	TA
Non-Operating Temperature		-34	+95	°C	TA

