

Technical Data of Ceramic Resonator

MURATA Part No.: CSTCE8M00G52-R0

Applied to M34584MD-XXXFP

Note: Suffix indicates packaging style.

·Lead type

-A0 : Flat pack package(Ho=18mm)

-B0 : Bulk

·SMD type

-R0 : Plastic tape package( $\varnothing$ =180mm)





-B0 : Bulk

**TOYAMA MURATA MANUFACTURING CO., LTD.**

Product Engineering Service Section I

Planning Department

Piezoelectric Components Group

Approved by	Checked by	Checked by	Issued by	Issued Date	Data No.
 K. Kuramoto	 K. Maruno	 K. Masaki	 K. Tagata	Mar 12, 2003	TCD-03-0433

## Contents

1.	Test Circuit	1
2.	Temperature Characteristics of Oscillating Frequency, Oscillating Voltage	2
3.	Rise Time, Oscillating Frequency, Oscillating Voltage vs Vdd Characteristics	3

## Test Circuit

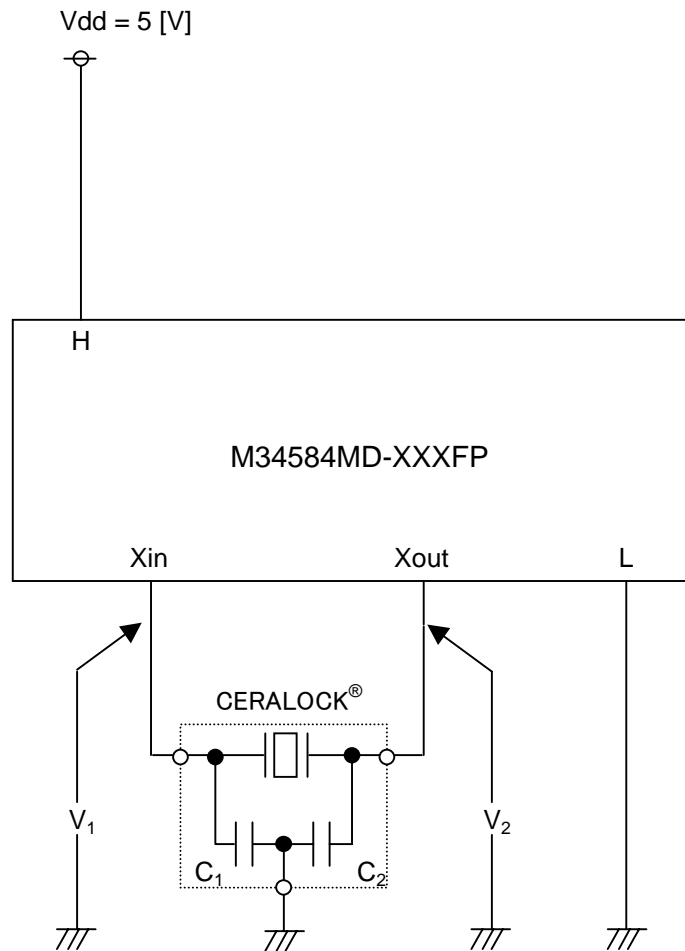

Xin : 20

Xout: 19

H : 22

L : 14~16,18,21,23,29

## Recommended Value

GERALOCK<sup>®</sup> : CSTCE8M00G52-R0

Vdd = 2.0 to 6.0 [V]

C1 = 10 [pF] (Typ.)

C2 = 10 [pF] (Typ.)

Ta = -20 to 85 [°C]

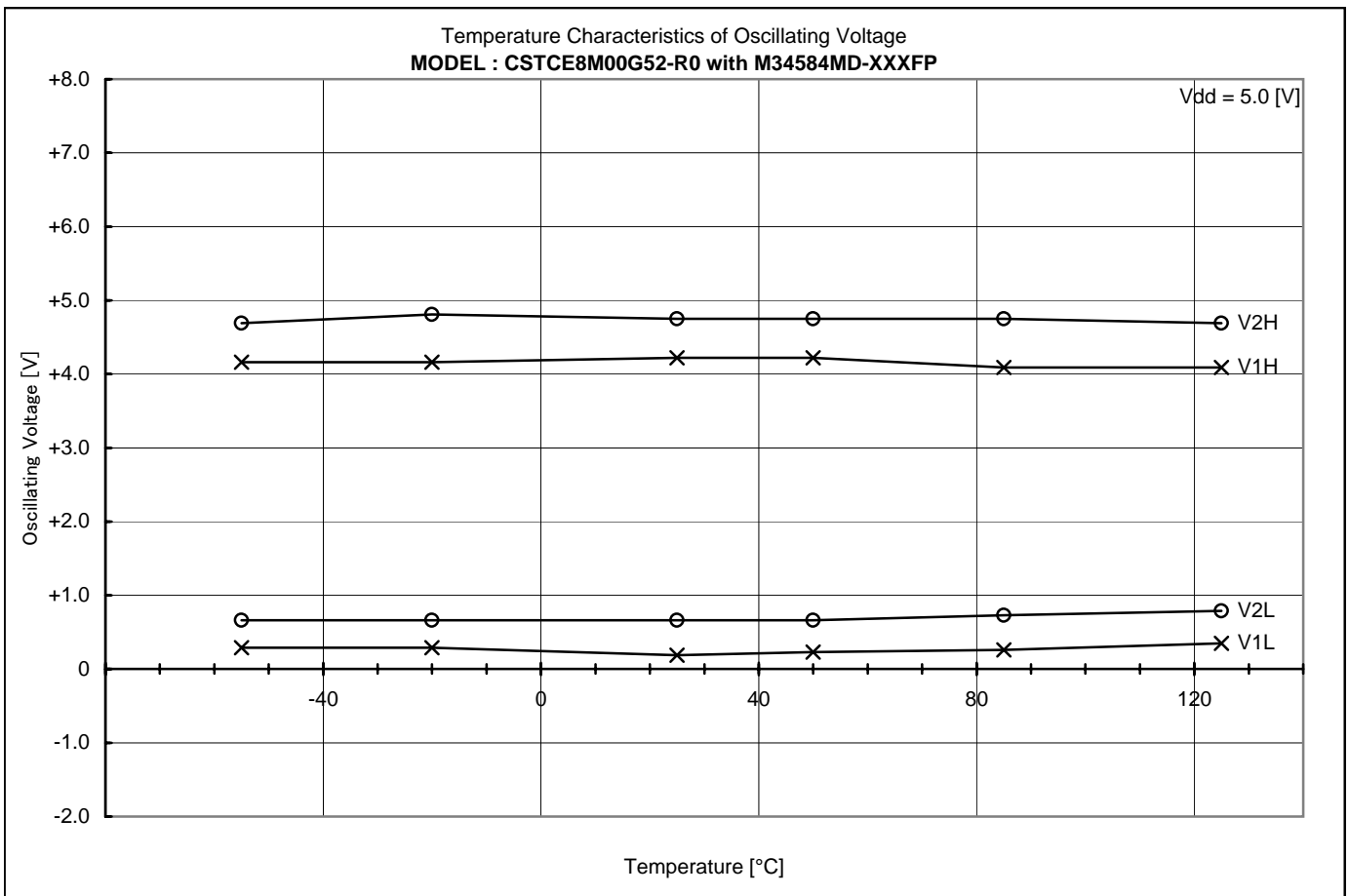
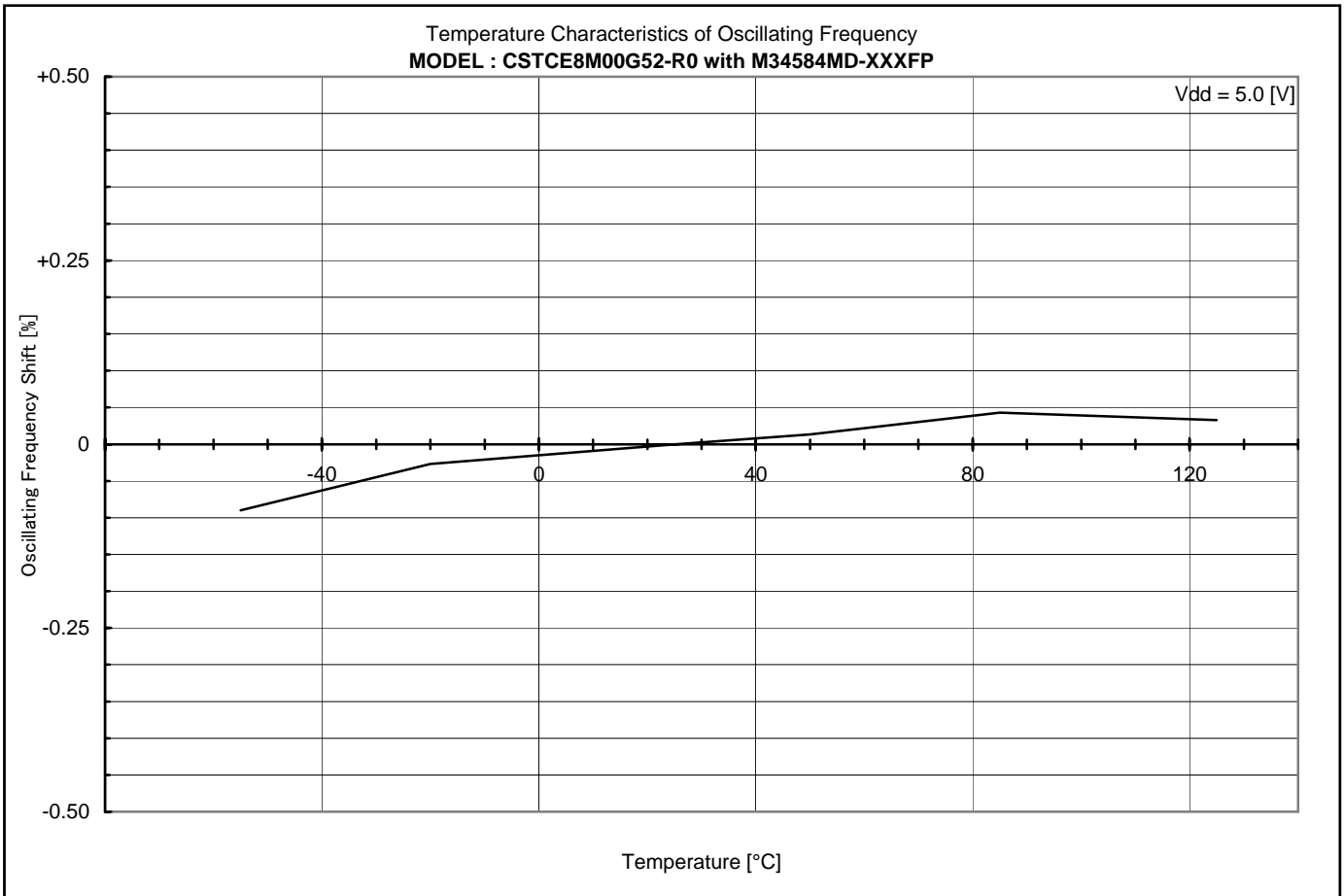

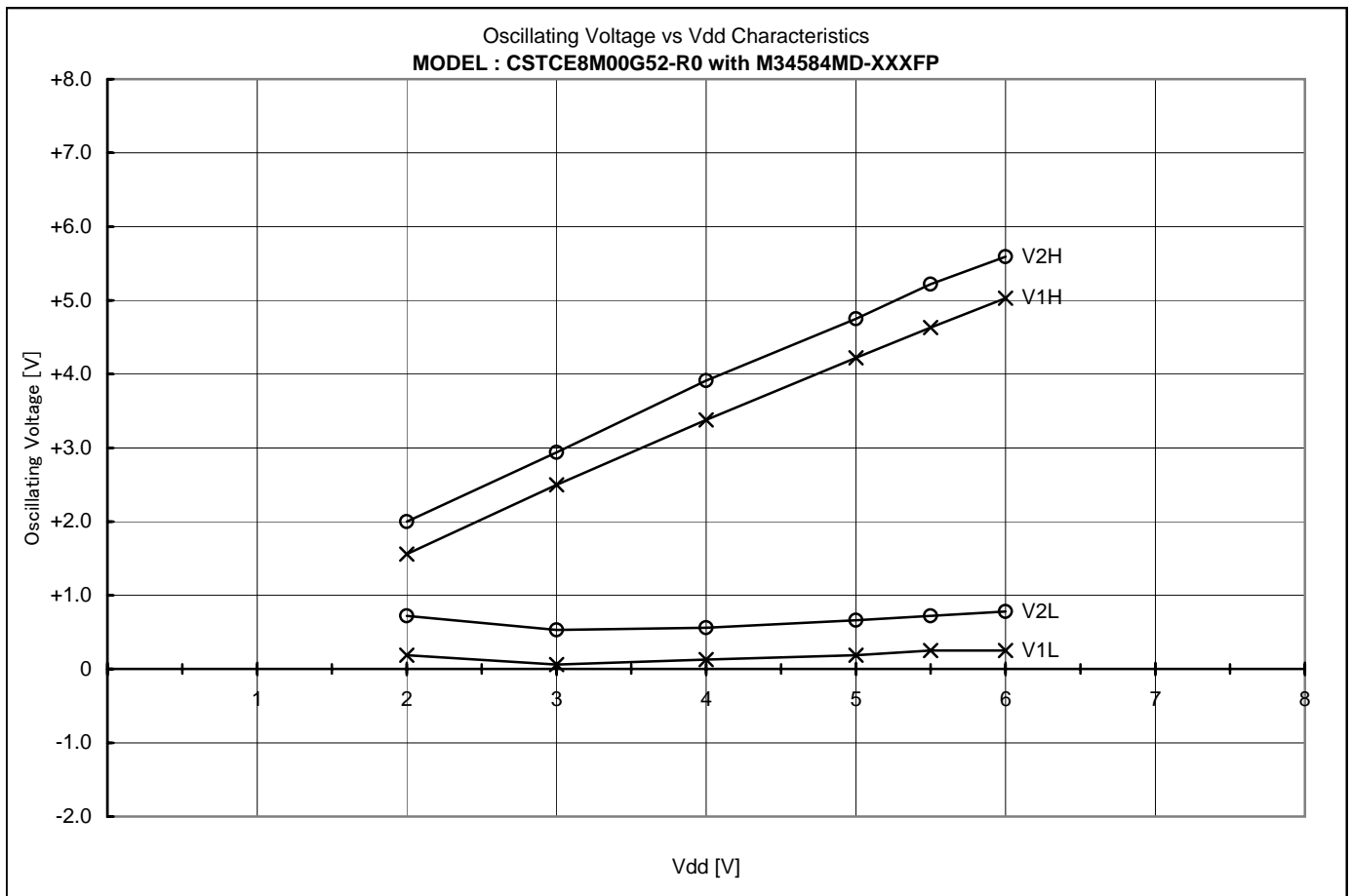
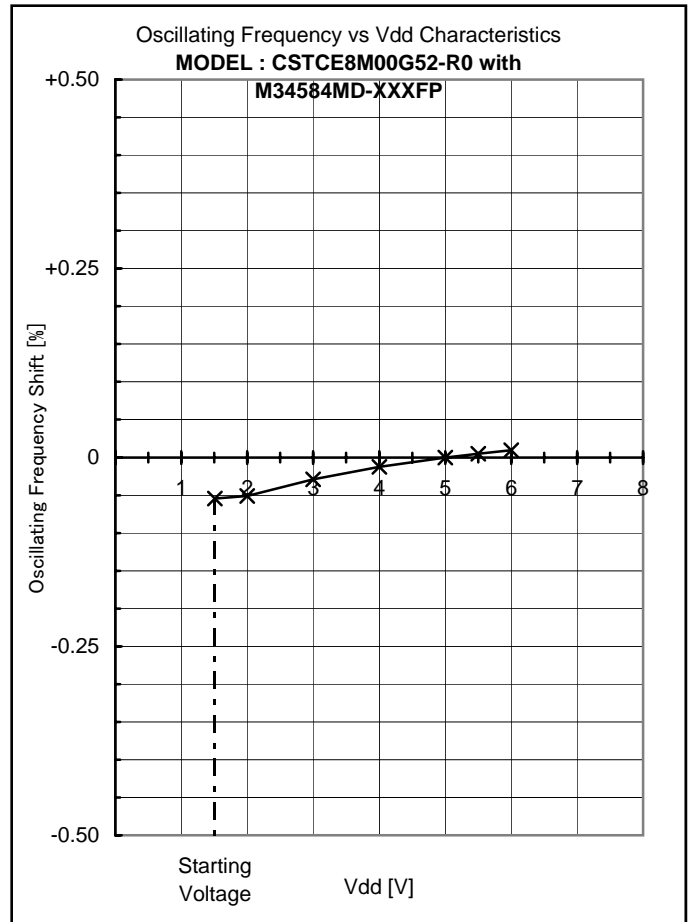
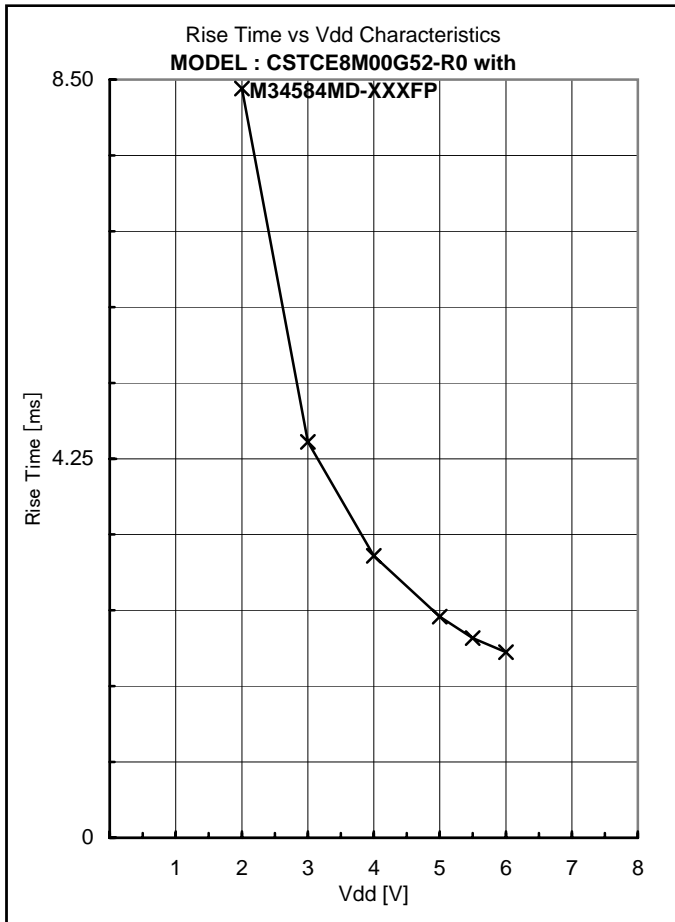



## Appendixes

4.	Comparison Table	4
5.	Frequency Correlation Data	5

### Comparison Table

IC : No	V1H [V]	V1L [V]	V1p-p [V]	V2H [V]	V2L [V]	V2p-p [V]	Fosc [kHz]	Trise [ms]	Vstart [V]
LL	4.31	0.19	4.12	4.78	0.66	4.12	7996.444	2.270	1.04
MM	4.22	0.19	4.03	4.81	0.66	4.15	7997.285	2.480	1.51
HH	4.28	0.13	4.15	4.81	0.63	4.18	7995.951	2.680	2.03

Ref.

Performance described page 2 to 3 were measured with IC No. MM



### Frequency Correlation Data

Sample No.	M34584MD-XXXFP Fosc [kHz]	TC4069UBP Fosc [kHz]	Shift [%]
1	7997.270	8010.200	-0.1614
2	8015.427	8021.200	-0.0720
3	8007.155	8019.200	-0.1502
4	8007.990	8020.100	-0.1510
5	7996.787	8012.400	-0.1949
— X	8004.926	8016.620	-0.1459

### muRata Standard Circuit

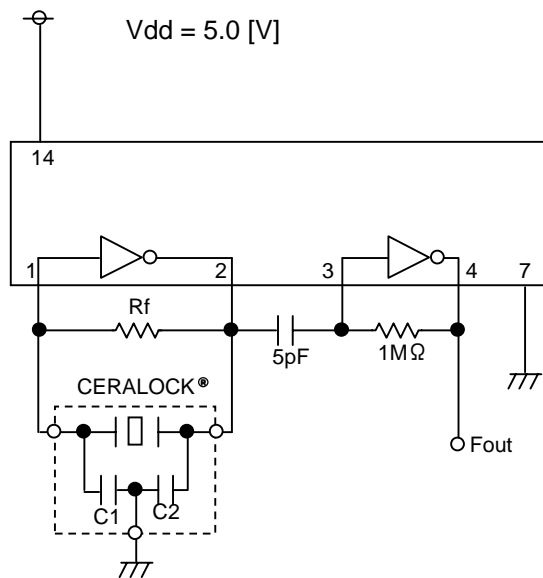

CERALOCK® : CSTCE8M00G52-R0

C1 = 10 [pF]

C2 = 10 [pF]

Rf = 1 [Mohm]