

## PAN301A CMOS HIGH PERFORMANCE OPTICAL MOUSE SENSOR

### General Description

The PAN301A is a high performance CMOS process optical mouse sensor with DSP integration chip that serves as a non-mechanical motion estimation engine for implementing a computer mouse.

### Features

- Single 5.0 volt power supply
- Precise optical motion estimation technology
- Complete 2-D motion sensor
- No mechanical parts
- Accurate motion estimation over a wide range of surfaces
- High speed motion detection up to 37 inches/sec and acceleration can be up to 20g
- High resolution up to 800dpi
- Power down pin and register setting for low power dissipation.
- Power saving mode during times of no movement
- Serial Interface for programming and data transfer
- I/O pin 5.0 volt tolerance

### Key Specification

<b>Power Supply</b>	<b>Wide operating supply range 4.5V~5.5V</b>
<b>Optical Lens</b>	<b>1:1</b>
<b>System Clock</b>	<b>18.432 MHz</b>
<b>Speed</b>	<b>37 inches/sec</b>
<b>Acceleration</b>	<b>20g</b>
<b>Resolution</b>	<b>400/600/800dpi</b>
<b>Frame Rate</b>	<b>3000 frames/sec</b>
<b>Operating Current</b>	<b>12mA @Mouse moving (Normal) 5mA @Mouse not moving (sleep1) 100uA @Power down mode</b>
<b>Package</b>	<b>Shrunk DIP20</b>

### Ordering Information

<b>Order number</b>	<b>I/O</b>	<b>Resolution</b>
PAN301ASI-204	CMOS output	400 dpi
PAN301ASI-208	CMOS output	800 dpi

1. Pin Description

Pin No.	Name	Type	Definition
1	VSS LED	GND	LED ground
2	LED	I/O	LED control
3	OSCOUT	OUT	Resonator output
4	OSCIN	IN	Resonator input
5	NC	-	No connection
6	VSS	GND	Chip ground
7	VSS	GND	Chip ground
8	VDD	PWR	Chip power, 5V power supply
9	VREFA	BYPASS	Analog voltage reference
10	VREFB	BYPASS	Analog voltage reference
11	YA	OUT	YA quadrature output
12	YB	OUT	YB quadrature output
13	XA	OUT	XA quadrature output
14	XB	OUT	XB quadrature output
15	NC	-	No connection
16	NC	-	No connection
17	NC	-	No connection
18	SCLK	IN	Serial interface clock
19	SDIO	I/O	Serial interface bi-direction data
20	PD	IN	Power down pin, active high

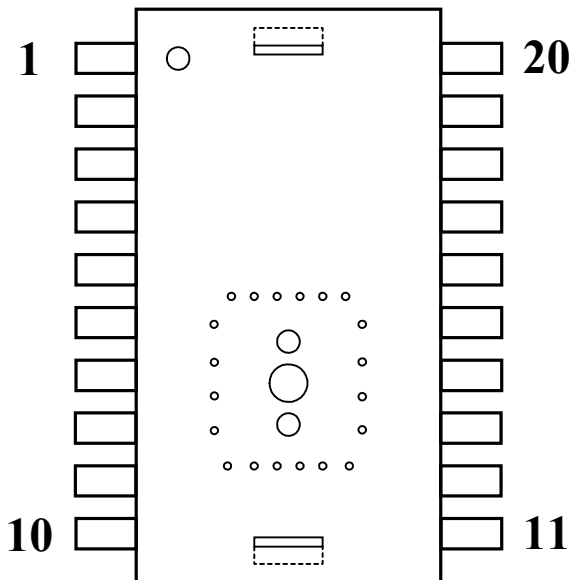

Figure 1. Top view pinout

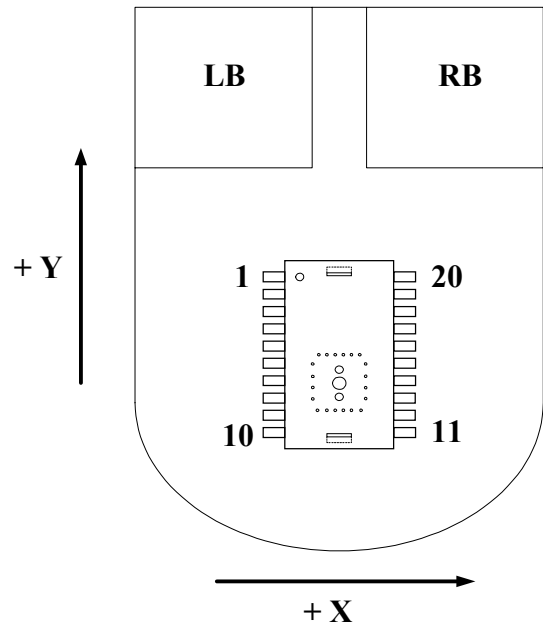
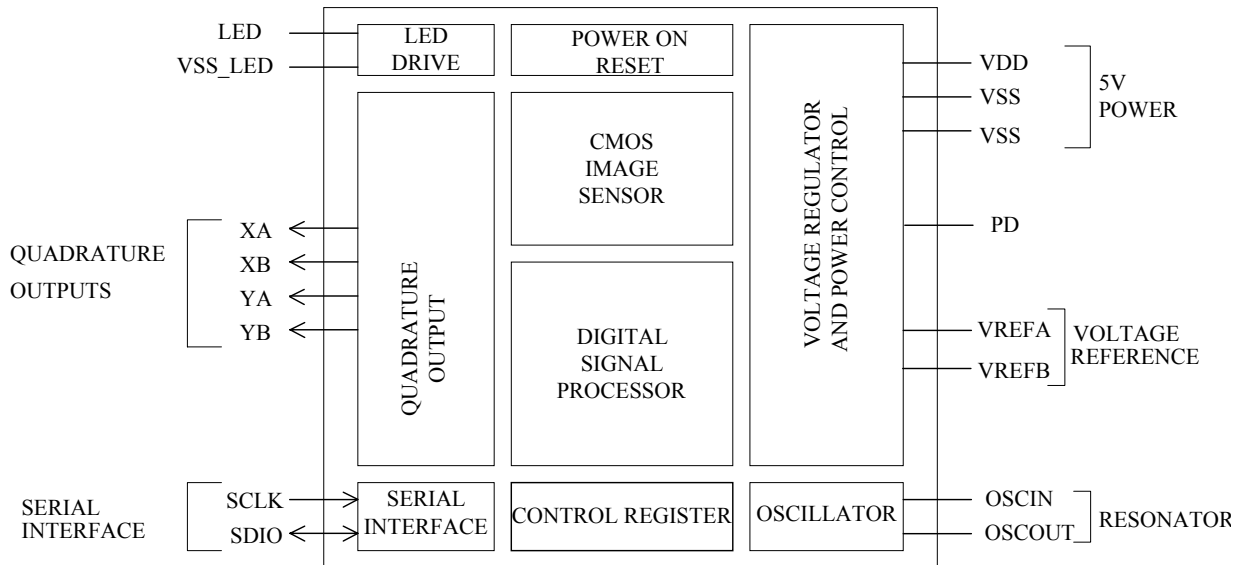

Figure 2. Top view of mouse

## 2. Block Diagram and Operation



**Figure 3. Block diagram**

The PAN301A is a high performance CMOS-process optical mouse sensor with DSP integration chip that serves as a non-mechanical motion estimation engine for implementing a computer mouse. It is based on new optical navigation technology, which measures changes in position by optically acquiring sequential surface images (frames) and mathematically determining the direction and magnitude of movement. The sensor is in a 20pin optical package. The output format is two-channel quadrature (X and Y direction), which emulates encoder phototransistors. The current X and Y information are also available in registers accessed via a serial port.

### 3. Registers and Operation

The PAN301A can be programmed through registers, via the serial port, and DSP configuration and motion data can be read from these registers. All registers not listed are reserved, and should never be written by firmware.

#### 3.1 Registers

Address	Name	R/W	Default	Data Type
0x00	Product ID	R	0x30	Eight bits [11:4] number with the product identifier
0x01	Product ID	R	0x1N	Four bits [3:0] number with the product identifier
0x02	Motion Status	R	-	Bit field
0x03	Delta X	R	-	Eight bits 2's complement number
0x04	Delta Y	R	-	Eight bits 2's complement number
0x05	Operation Mode	R/W	-	Bit field
0x06	Configuration	R/W	-	Bit field

#### 3.2 Register Descriptions

<b>0x00</b>	<b>Product_ID</b>							
Bit	7	6	5	4	3	2	1	0
Field	PID[11:4]							
Usage	The value in this register can't change. It can be used to verify that the serial communications link is OK.							
<b>0x01</b>	<b>Product_ID</b>							
Bit	7	6	5	4	3	2	1	0
Field	PID[3:0]				Reserved [3:0]			
Usage	The value in this register can't change. It can be used to verify that the serial communications link is OK.							

0x02	Motion_Status							
Bit	7	6	5	4	3	2	1	0
Field	Motion	Reserved[6:5]		DYOVF	DXOVF	RES[2:1]		Reserved
Usage	<p>Register 0x02 allows the user to determine if motion has occurred since the last time it was read. If so, then the user should read registers 0x03 and 0x04 to get the accumulated motion. It also tells if the motion buffers have overflowed since the last reading. The current resolution is also shown.</p> <p>Reading this register freezes the Delta_X and Delta_Y register values. Read this register before reading the Delta_X and Delta_Y registers. If Delta_X and Delta_Y are not read before the motion register is read a second time, the data in Delta_X and Delta_Y will be lost.</p>							
Notes	Field Name	Description						
	Motion	Motion since last report or PD <b>0 = No motion (Default)</b> 1 = Motion occurred, data ready for reading in Delta_X and Delta_Y registers						
	Reserved[6:5]	Reserved for future						
	DYOVF	Motion Delta Y overflow, ΔY buffer has overflowed since last report <b>0 = No overflow (Default)</b> 1 = Overflow has occurred						
	DXOVF	Motion Delta X overflow, ΔX buffer has overflowed since last report <b>0 = No overflow (Default)</b> 1 = Overflow has occurred						
	RES[2:1]	Resolution in counts per inch <b>0 = 800 (Default @ PAN301ASI-208)</b> <b>1 = 400 (Default @ PAN301ASI-204)</b> 2 = 600						
	Reserved	Reserved for future						
0x03	Delta_X							
Bit	7	6	5	4	3	2	1	0
Field	X7	X6	X5	X4	X3	X2	X1	X0
Usage	X movement is counts since last report. Absolute value is determined by resolution. Reading clears the register. Report range -128~+127.							
0x04	Delta_Y							
Bit	7	6	5	4	3	2	1	0
Field	Y7	Y6	Y5	Y4	Y3	Y2	Y1	Y0
Usage	Y movement is counts since last report. Absolute value is determined by resolution. Reading clears the register. Report range -128~+127.							

0x05	Operation_Mode																
Bit	7	6	5	4	3	2	1	0									
Field	LEDsht_enh	XY_enh	Reserved	Slp_enh	Slp2au	Slp2mu	Slp1mu	Wakeup									
Usage	<p>Register 0x05 allows the user to change the operation of the sensor. Shown below are the bits, their default values, and optional values.</p> <p>Operation_Mode[4:0]                      “0xxxx”=Disable sleep mode                      “10xxx”=Enable sleep mode<sup>1</sup>                      “11xxx”=Enable sleep mode<sup>2</sup>                      “1x100”=Force enter sleep2<sup>3</sup>                      “1x010”=Force enter sleep1<sup>3</sup>                      “1x001”=Force wakeup from sleep mode<sup>3</sup></p> <p>Notes:</p> <ol style="list-style-type: none"> <li>1. Enable sleep mode, but disable automatic entering sleep2 mode, that is, only 2 modes will be used, normal mode and sleep1 mode. After 1 sec not moving during normal mode, the chip will enter sleep1 mode, and keep on sleep1 mode until moving is detected or wakeup is asserted.</li> <li>2. Enable sleep mode full function, that is 3 modes will be used, normal mode, sleep1 mode and sleep2 mode. After 1 sec not moving during normal mode, chip will enter sleep1 mode, and keep on sleep1 mode until moving is detected or wakeup is asserted.                       And after 60 sec not moving during sleep1 mode, the chip will enter sleep2 mode, and keep on sleep2 mode until detect moving or force wakeup to normal mode.</li> </ol> <table border="1"> <thead> <tr> <th>Mode</th> <th>Sampling rate @3000frame/sec</th> <th>Active duty cycle @3000frame/sec</th> </tr> </thead> <tbody> <tr> <td>Sleep1</td> <td>94/sec</td> <td>22%</td> </tr> <tr> <td>Sleep2</td> <td>3/sec</td> <td>2.24%</td> </tr> </tbody> </table> <ol style="list-style-type: none"> <li>3. Only one of these three bits slp2mu_enh, slp1mu_enh, and wakeup can be set to 1 at the same time, others have to be set to 0. After a period of time, the bits, which was set to 1, will be reset to 0 by internal signal.</li> </ol>								Mode	Sampling rate @3000frame/sec	Active duty cycle @3000frame/sec	Sleep1	94/sec	22%	Sleep2	3/sec	2.24%
Mode	Sampling rate @3000frame/sec	Active duty cycle @3000frame/sec															
Sleep1	94/sec	22%															
Sleep2	3/sec	2.24%															
Notes	<b>Field Name</b>	<b>Description</b>															
	LEDsht_enh	LED shutter enable / disable 0 = Disable <b>1 = Enable (Default)</b>															
	XY_enh	XY quadrature output enable/disable 0 = Disable <b>1 = Enable (Default)</b>															
	Reserved	Reserved for future															
	Slp_enh	Sleep mode enable/disable 0 = Disable <b>1 = Enable (Default)</b>															
	Slp2au	Automatic enter sleep2 mode enable/disable <b>0 = Disable (Default)</b> 1 = Enable															
	Slp2mu	Manual enter sleep2 mode, set “1” will enter sleep2 and this bit will be reset to “0”															
	Slp1mu	Manual enter sleep1 mode, set “1” will enter sleep2 and this bit will be reset to “0”															
	Wakeup	Manual wake up from sleep mode, set “1” will enter wakeup and this bit will be reset to “0”															

0x06	Configuration							
Bit	7	6	5	4	3	2	1	0
Field	Reserved[7:4]				PD	RES[2:1]		Reserved
Usage	The Configuration register allows the user to change the configuration of the sensor. Shown below are the bits, their default values, and optional values.							
Notes	<b>Field Name</b>	<b>Description</b>						
	Reserved[7:4]	Reserved for future						
	PD	Power down mode <b>0 = Normal operation (Default)</b> 1 = Power down mode						
	RES[2:1]	Output resolution setting <b>0 = 800 (Default @ PAN301ASI-208)</b> <b>1 = 400 (Default @ PAN301ASI-204)</b> 2 = 600						
	Reserved	Reserved for future						

## 4. Specifications

### Absolute Maximum Ratings

Symbol	Parameter	Min	Max	Unit	Notes
T <sub>STG</sub>	Storage temperature	-40	85	°C	
TA	Operating Temperature	-15	55	°C	
	Lead Solder Temp		260	°C	For 10 seconds, 1.6mm below seating plane.
V <sub>DD</sub>	DC supply voltage	-0.5	5.5	V	
ESD			2	kV	All pins, human body model MIL 883 Method 3015
V <sub>IN</sub>	DC input voltage	-0.5	5.5	V	PD, SDIO, SCLK, XA, XB, YA, YB, VDD

### Recommend Operating Condition

Symbol	Parameter	Min.	Typ.	Max.	Unit	Notes
T <sub>A</sub>	Operating Temperature	0		40	°C	
V <sub>DD</sub>	Power supply voltage	4.5	5.0	5.5	V	
V <sub>N</sub>	Supply noise			100	mV	Peak to peak within 0-100 MHz
F <sub>CLK</sub>	Clock Frequency		18.432	24.576	MHz	Set by ceramic resonator
FR	Frame Rate		3000	4000	Frames/s	4000Frames/s @ F <sub>CLK</sub> =24.567MHz
SCLK	Serial Port Clock Frequency			10	MHz	
Z	Distance from lens reference plane to surface	2.3	2.4	2.5	mm	Refer to Figure 4.
S	Speed	0	18	37	Inches/sec	
A	Acceleration			20	g	
R	Resolution		400	800	cpi	



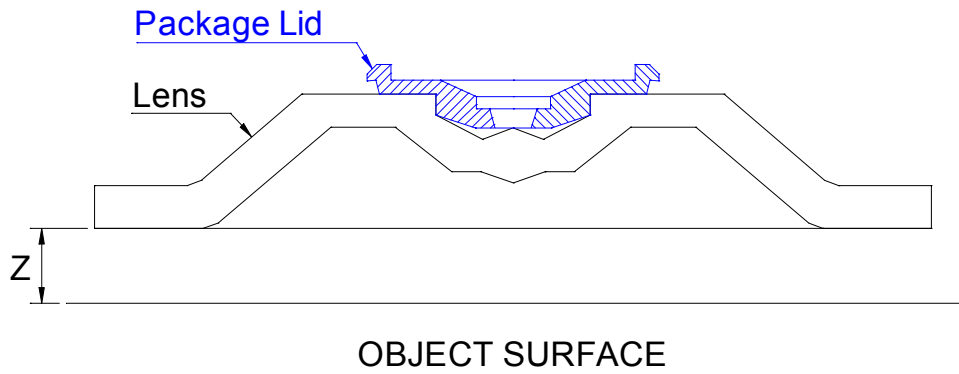

Figure 4. Distance from Lens Reference Plane to Surface

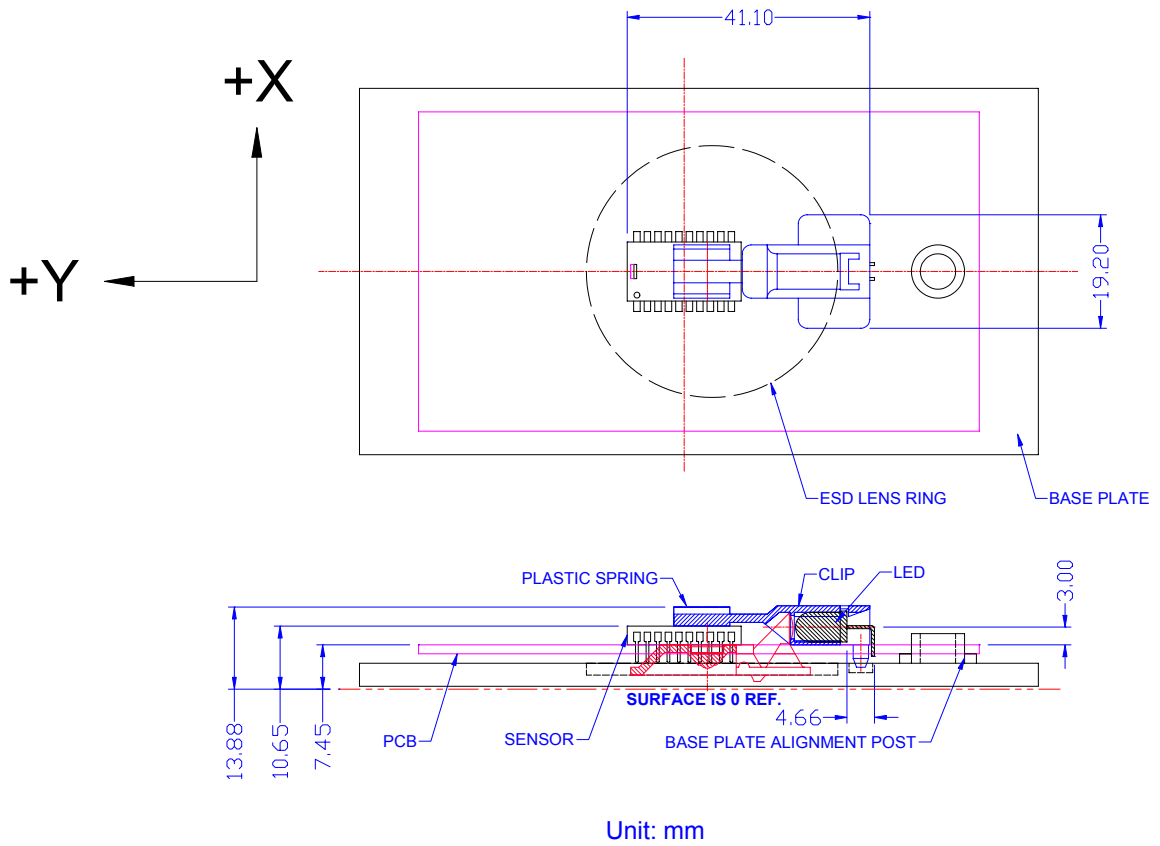

Figure 5. 2D assembly

**AC Operating Condition**Electrical Characteristics over recommended operating conditions. Typical values at 25 °C,  $V_{DD} = 5.0$  V

Symbol	Parameter	Min.	Typ.	Max.	Unit	Notes
$t_{PD}$	Power Down		500		us	From PD $\uparrow$ . (Refer to Figure 15)
$t_{PDW}$	PD Pulse Width	700			us	Pulse width to reset the serial interface. (Refer to Figure 15)
$t_{PDR}$	PD Pulse Register			333	us	One frame time maximum after setting bit 2 in the Configuration register @3000frame/sec. (Refer to Figure 17)
$t_{PUPD}$	Power Up from PD $\downarrow$	8		30.5	ms	From PD $\downarrow$ to valid quad signals. After $t_{PUPD}$ , all registers contain valid data from first image after PD $\downarrow$ . Note that an additional 90 frames for Auto-Exposure (AE) stabilization may be required if mouse movement occurred while PD was high. (Refer to Figure 15)
$t_{PU}$	Power Up from $V_{DD}\uparrow$	8		30.5	ms	From $V_{DD}\uparrow$ to valid quad signals. 500usec + 90frames.
$t_{HOLD}$	SDIO read hold time		3		us	Minimum hold time for valid data. (Refer to Figure 11)
$t_{RESYNC}$	Serial Interface RESYNC.	1			us	@3000frame/sec (Refer to Figure 14)
$t_{SIWTT}$	Serial Interface Watchdog Timer Timeout	1.7			ms	@3000frame/sec (Refer to Figure 14)
$t_r, t_f$	Rise and Fall Times: SDIO		25, 20		ns	$C_L = 30$ pf
$t_r, t_f$	Rise and Fall Times: XA, XB, YA, YB		25, 20		ns	$C_L = 30$ pf
$t_r, t_f$	Rise and Fall Times: ILED		10, 10		ns	LED bin grade: R; R1=100ohm

**DC Electrical Characteristics**Electrical Characteristics over recommended operating conditions. Typical values at 25 °C,  $V_{DD} = 5.0$  V

Symbol	Parameter	Min.	Typ.	Max.	Unit	Notes
<b>Type: PWR</b>						
$I_{DD}$	Supply Current Mouse moving (Normal)		12		mA	XA, XB, YA, YB, SCLK, SDIO = no load
$I_{DD}$	Supply Current Mouse not moving (sleep1)		5		mA	
$I_{DDPD}$	Supply Current (Power Down)		100		uA	PD, SCLK, SDIO = high
<b>Type: SCLK, SDIO, PD</b>						
$V_{IH}$	Input voltage HIGH	2.0				
$V_{IL}$	Input voltage LOW			0.7	V	
$V_{OH}$	Output voltage HIGH	2.4			V	@ $I_{OH} = 2\text{mA}$ (SDIO only)
$V_{OL}$	Output voltage LOW			0.6	V	@ $I_{OL} = 2\text{mA}$ (SDIO only)
<b>Type: OSCIN</b>						
$V_{IH}$	Input voltage HIGH	2.0			V	When driving from an external source
$V_{IL}$	Input voltage LOW			0.7	V	When driving from an external source
<b>Type: LED</b>						
$V_{OL}$	Output voltage LOW			150	mV	@ $I_{OL} = 25\text{mA}$
<b>Type: XA, XB, YA, YB</b>						
$V_{OH}$	Output voltage HIGH	2.4			V	@ $I_{OH} = 2\text{mA}$
$V_{OL}$	Output voltage LOW			0.6	V	@ $I_{OL} = 2\text{mA}$

### 5. Quadrature Mode

The quadrature state of the PAN301A tells mouse controller which direction the mouse is moving in. The output format is two channels quadrature (X and Y direction), which emulates encoder phototransistors. The DSP generates the  $\Delta x$  and  $\Delta y$  relative displacement values that are converted into two channel quadrature signals. The following diagrams show the timing for positive X motion, to the right or positive Y motion, up.

#### 5.1 Quadrature Output Timing

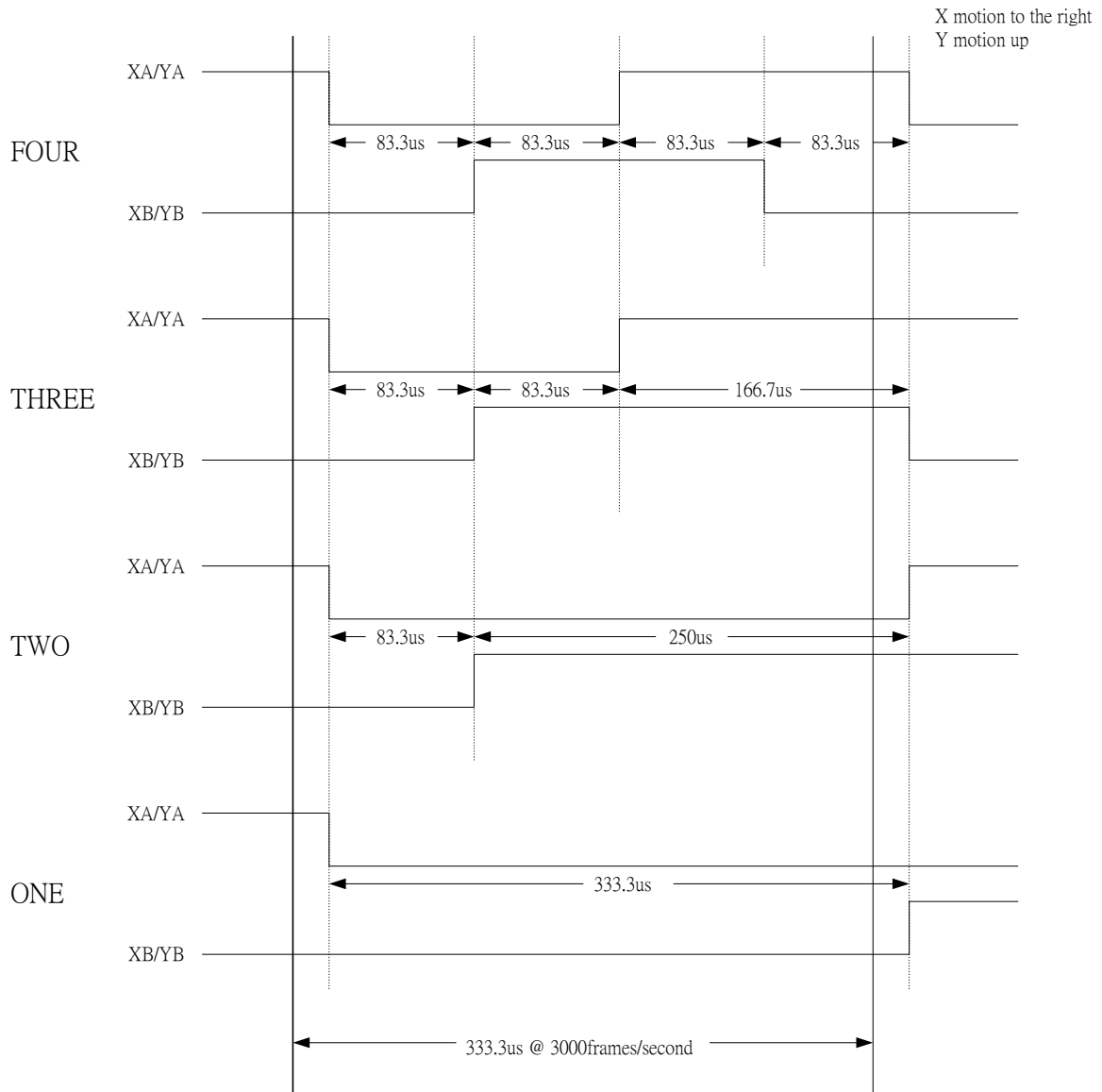

Figure 6. Quadrature output timing

### 5.2 Quadrature Output State Machine

The following state machine shows the states of the quadrature output pins. The three things to note are that state 0 is entered after a power on reset. While the PD pin is asserted, the state machine is halted. Once PD is de-asserted, the state machine picks up from where it left off. During times of mouse no movement will entry power saving mode, until mouse was moved.

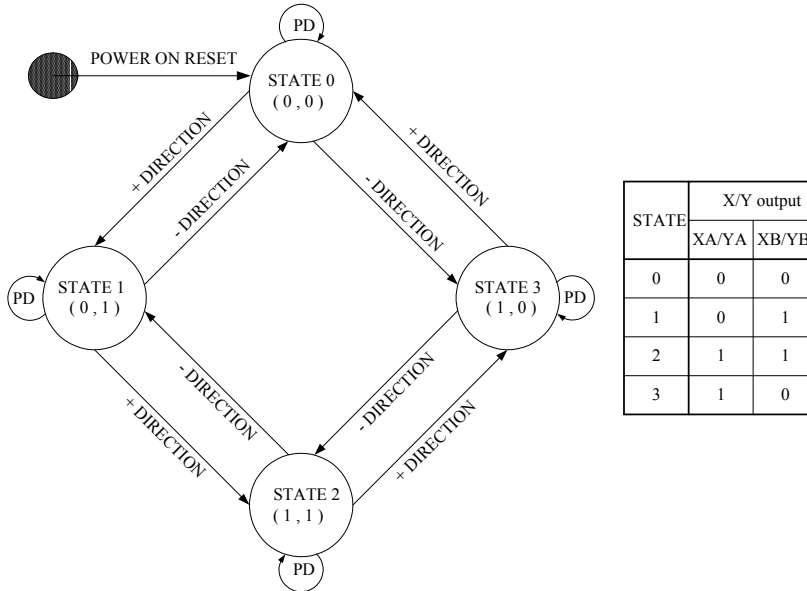

Figure 7. State machine

### 5.3 Quadrature Output Waveform

The following diagrams show the waveform of the two channel quadrature outputs. If the X, Y is motionless, the (XA, XB), (YA, YB) will keep in final state. Each state change (ex. STATE2 → STATE3) is one count.

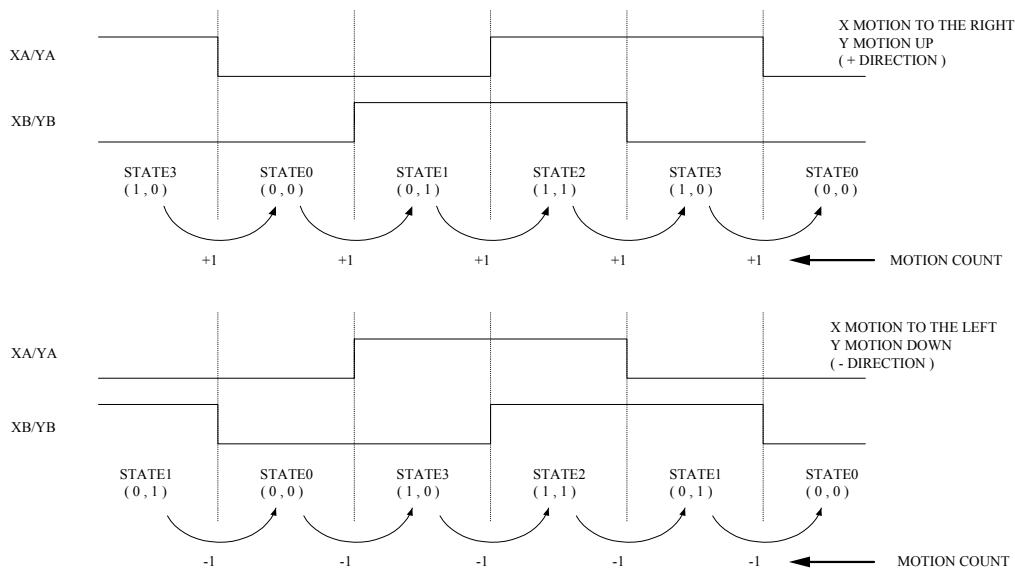

Figure 8. Quadrature output waveform

## 6. Serial Interface

The synchronous serial port is used to set and read parameters in the PAN301A, and can be used to read out the motion information instead of the quadrature data pins.

**SCLK:** The serial clock line. It is always generated by the host micro-controller.

**SDIO:** The serial data line used for write and read data.

**PD:** A third line is sometimes involved. PD(Power Down pin) is usually used to place the PAN301A in a low power mode to meet USB suspend specification. PD can also be used to force re-synchronization between the micro-controller and the PAN301A in case of an error.

### 6.1 Transmission Protocol

The transmission protocol is a two-wire link, half duplex protocol between the micro-controller and PAN301A. All data changes on SDIO are initiated by the falling edge on SCLK. The host micro-controller always initiates communication; the PAN301A never initiates data transfers.

The transmission protocol consists of the two operation modes:

- Write Operation.
- Read Operation.

Both of the two operation modes consist of two bytes. The first byte contains the address (seven bits) and has a bit7 as its MSB to indicate data direction. The second byte contains the data.

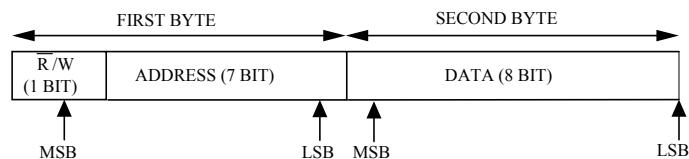

Figure 9. Transmission protocol

#### 6.1.1 Write Operation

A write operation, which means that data is going from the micro-controller to the PAN301A, is always initiated by the micro-controller and consists of two bytes. The first byte contains the address (seven bits) and has a “1” as its MSB to indicate data direction. The second byte contains the data. The transfer is synchronized by SCLK. The micro-controller changes SDIO on falling edges of SCLK. The PAN301A reads SDIO on rising edges of SCLK.

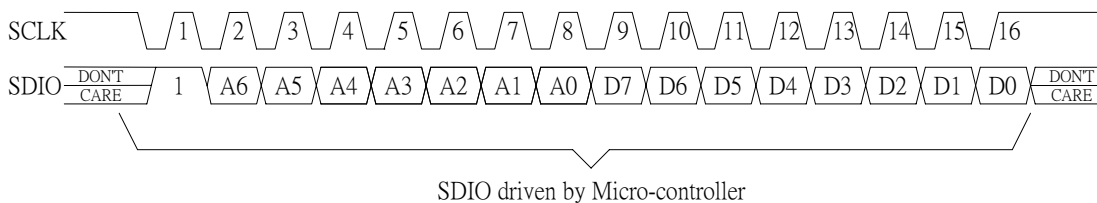

Figure 10. Write operation

#### 6.1.2 Read Operation

A read operation, which means that data is going from the PAN301A to the micro-controller, is always initiated by the micro-controller and consists of two bytes. The first byte contains the address, is written by the micro-controller, and has a “0” as its MSB to indicate data direction. The second byte contains the data and is driven by the PAN301A. The transfer is synchronized by SCLK. SDIO is changed on falling

edges of SCLK and read on every rising edge of SCLK. The micro-controller must go to a high Z state after the last address data bit. The PAN301A will go to the high Z state after the last data bit.

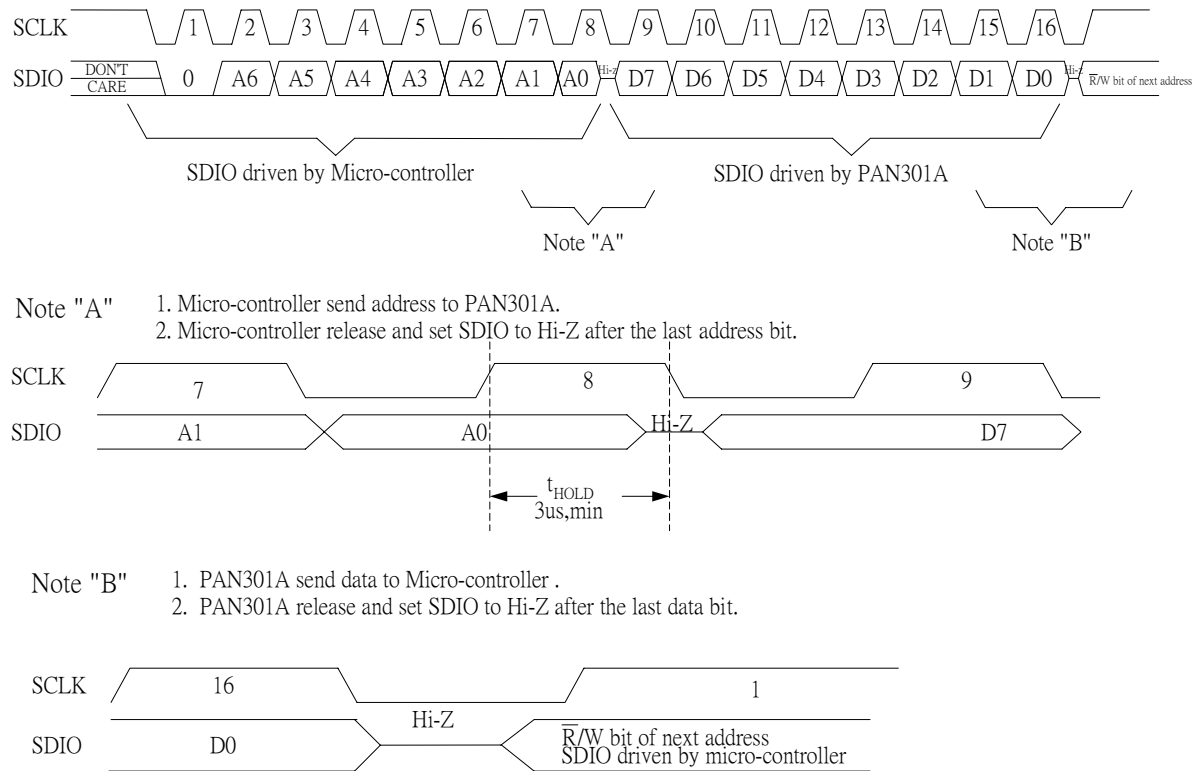

Figure 11. Read operation

## 6.2 Re-Synchronous Serial Interface

There are times when the SDIO line from the PAN301A should be in the Hi-Z state. If the microprocessor has completed a write to the PAN301A, the SDIO line is Hi-Z, since the SDIO pin is still configured as an input. However, if the last operation from the microprocessor was a read, the PAN301A will hold the D0 state on SDIO until a rising edge of SCLK. To place the SDIO pin into the Hi-Z state, first raise the PD line, and then toggle the SCLK line from high to low to high. The SDIO line will now be in the Hi-Z state. The PAN301A and the micro-controller might get out of synchronization due to following condition.

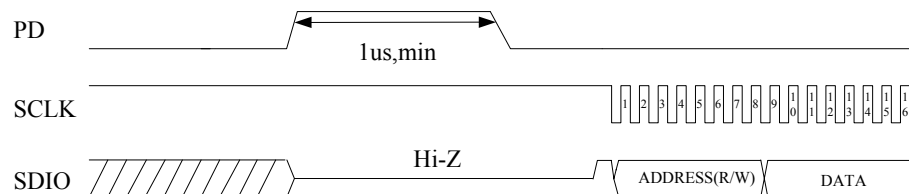

Figure 12. Forcing PAN301A SDIO line to the Hi-Z state

### 6.2.1 USB Suspend

Termination of a transmission by the micro-controller may sometimes be required (for example, due to a USB suspend interrupt during a read operation). To accomplish this the micro-controller should raise PD.

The PAN301A will not write to any register and will reset the serial port (but nothing else) and be prepared for the beginning of future transmissions after PD goes low.

### 6.2.2 Firmware Flaws Error, or Others Error

The PAN301A and the micro-controller might get out of synchronization due to micro-controller firmware flaws. The PD pin can stay high, with the PAN301A in the shutdown state, or the PD pin can be lowered, returning the PAN301A to normal operation.

If the microprocessor and the PAN301A get out of sync, then the data either written or read from the registers will be incorrect. In such a case, an easy way to solve this is to raise PD to re-sync the parts after an incorrect read. The PAN301A will reset the serial port but will not reset the registers and be prepared for the beginning of a new transmission.

### 6.2.3 Power On Problem

The problem occurs if the PAN301A powers up before the microprocessor sets the SCLK and SDIO lines to be output.

### 6.2.4 ESD Events

The PAN301A and the micro-controller might get out of synchronization due to ESD events.

If the PAN301A and the micro-controller might get out of synchronization due to power on problem or ESD events. An easy way to solve this is to soft reset the PAN301A.

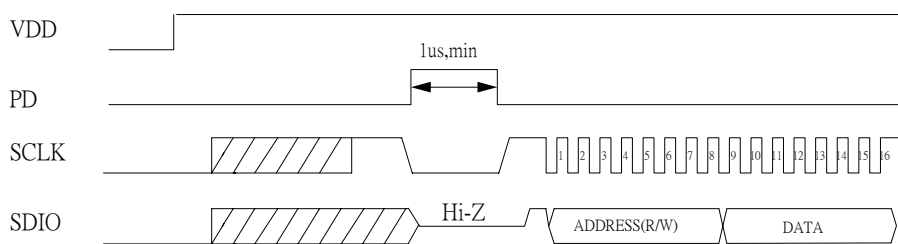

Figure 13. Soft reset the PAN301A (Reset full chip and SDIO line set to Hi-Z state)

## 6.3 Collision Detection on SDIO

The only time that the PAN301A drives the SDIO line is during a READ operation. To avoid data collisions, the micro-controller should release SDIO before the falling edge of SCLK after the last address bit. The PAN301A begins to drive SDIO after the next falling edge of SCLK. The PAN301A release SDIO of the rising SCLK edge after the last data bit. The micro-controller can begin driving SDIO any time after that. In order to maintain low power consumption in normal operation or when the PD pin is pulled high, the micro-controller should not leave SDIO floating until the next transmission (although that will not cause any communication difficulties).

## 6.4 Serial Interface Watchdog Timer Timeout

When there are only two pins to read register from PAN301A, and PD pin can't be used to re-synchronous function. If the microprocessor and the PAN301A get out of sync, then the data either written or read from the registers will be incorrect. In such a case, an easy way to solve this condition is to toggle the SCLK line from high to low to high and wait at least  $t_{SIWTT}$  to re-sync the parts after an incorrect read. The PAN301A will reset the serial port but will not reset the registers and be prepared for the beginning of a new transmission.



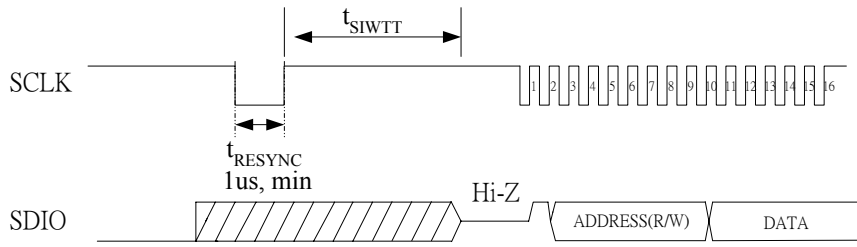

Figure 14. Re-synchronous serial interface using watchdog timer timeout

## 6.5 Power Down Mode

There are two different ways to entry power down mode, using the PD line or register setting.

### 6.5.1 PD Line Power Down Mode

To place the PAN301A in a low power mode to meet USB suspend specification, raise the PD line at least 700us. Then PD line can stay high, with the PAN301A in the shutdown state, or the PD pin can be lowered, returning the PAN301A to normal operation.

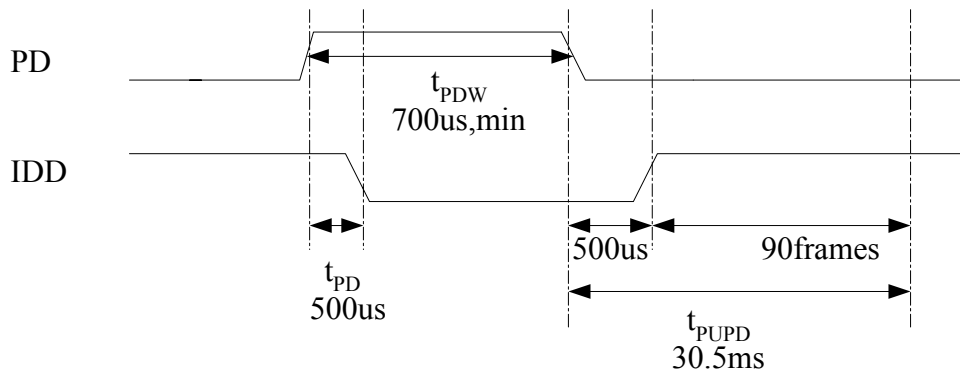

Figure 15. Power down minimum pulse width

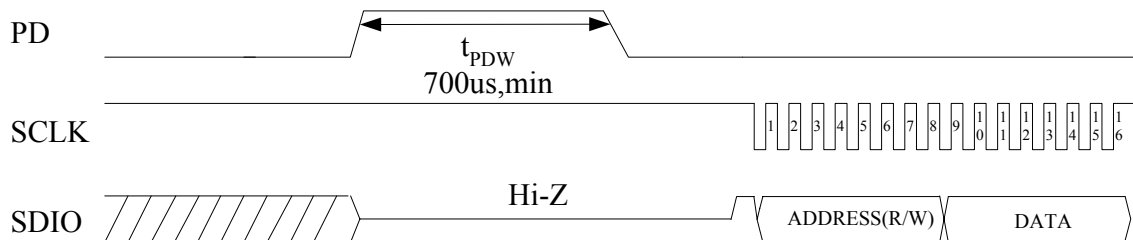

Figure 16. PD line power down mode

### 6.5.2 Register Power Down Mode

PAN301A can be placed in a power-down mode by setting bit 3 in the configuration register via a serial port write operation. After setting the configuration register, wait at least 1 frame times. To get the chip out of the power-down mode, clear bit 3 in the configuration register via a serial port write operation. In power-down mode, the serial interface watchdog timer is not available. But, The serial interface still can read/write normally. For an accurate report after leave power down mode, wait about 3ms before the micro-controller is able to issue any write/read operation to the PAN301A.

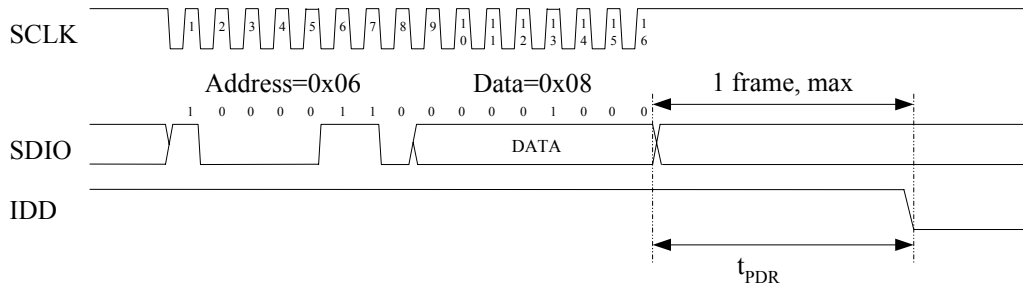

Figure 17. Power-down configuration register writing operation

### 6.6 Error Detection

1. The micro-controller can verify success of write operations by issuing a read command to the same address and comparing written data to read data.
2. The micro-controller can verify the synchronization of the serial port by periodically reading the product ID register.

## 7. Referencing Application Circuit

### 7.1 Recommended Typical Application using Serial Interface

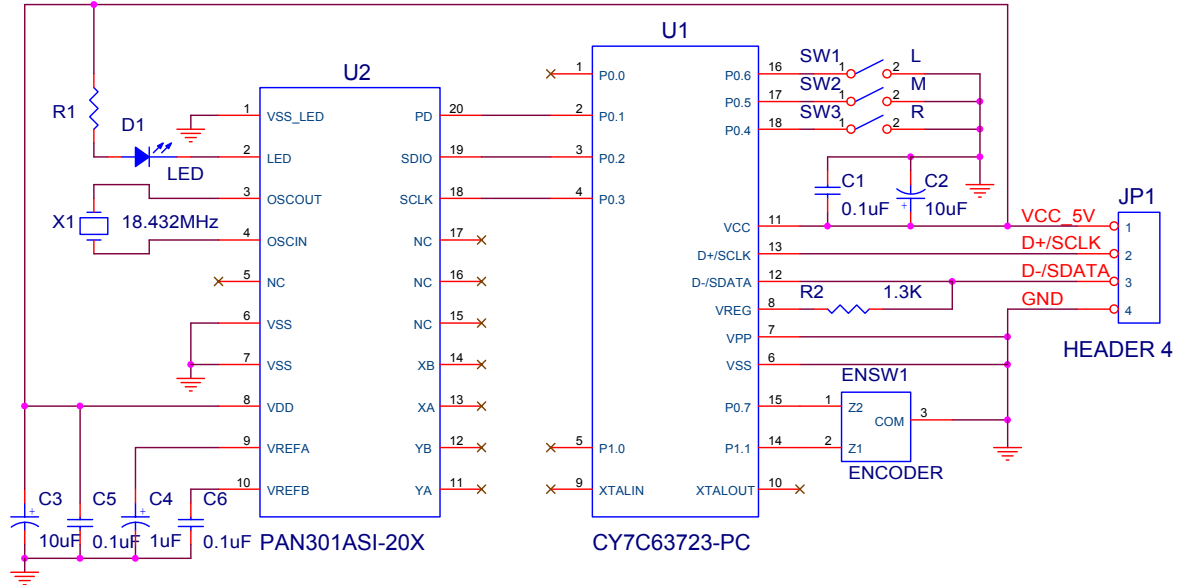

Figure 18. Application circuit using serial interface with PAN301ASI-20X

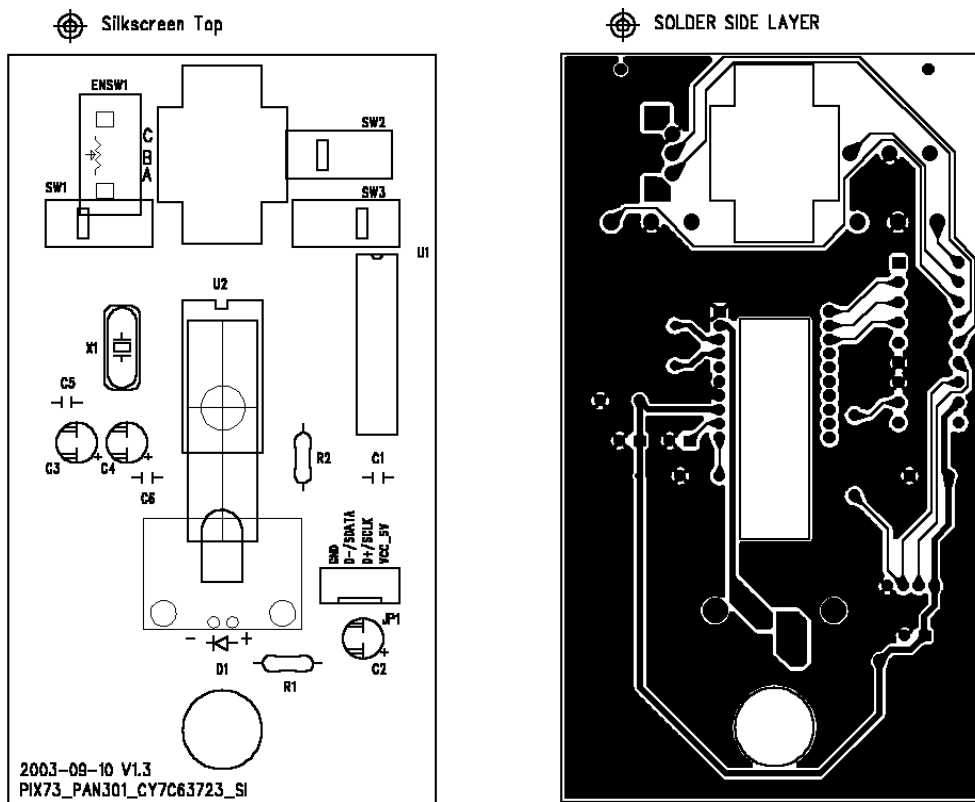

Figure 19. Example printed circuit board layout. (PAN301ASI-20X V.S CY7C63723-PC)

7.2 Application Circuit using Quadrature Output Pins

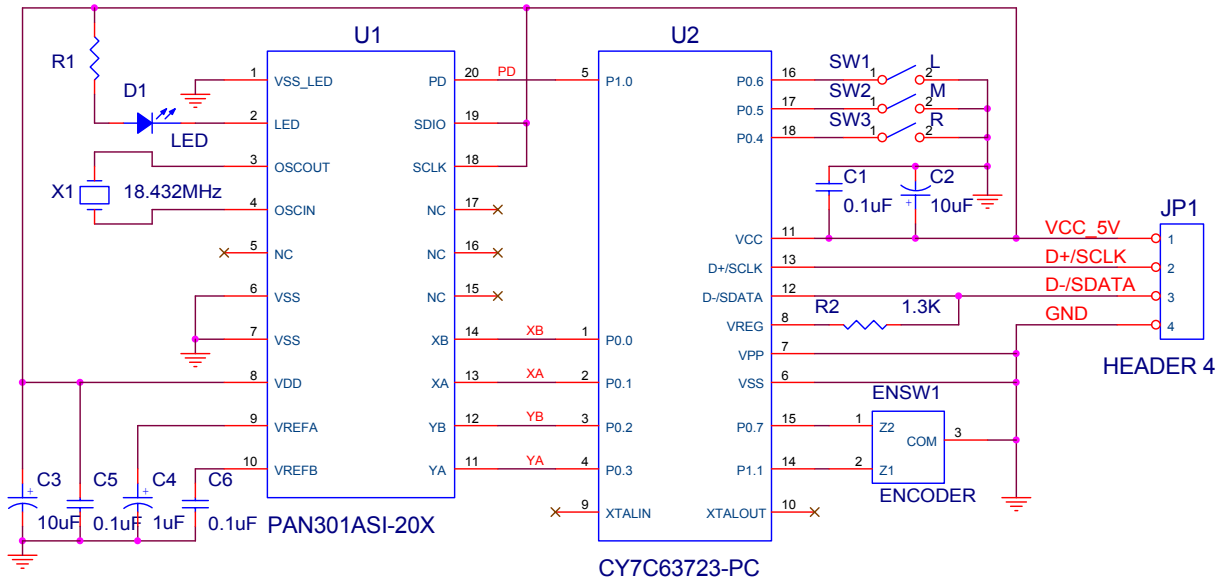

Figure 20. Application circuit using quadrature output with PAN301ASI-20X

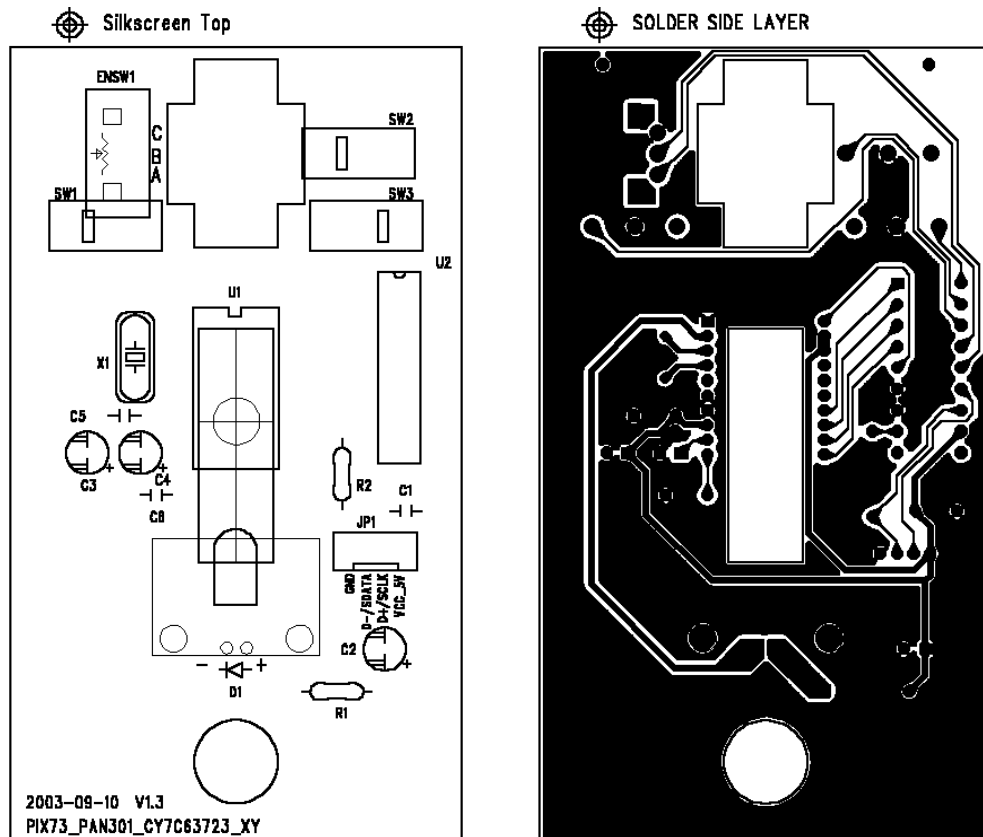

Figure 21. Example printed circuit board layout. (PAN301ASI-20X V.S CY7C63723-PC)

7.3 Typical Application for PS/2 Interface

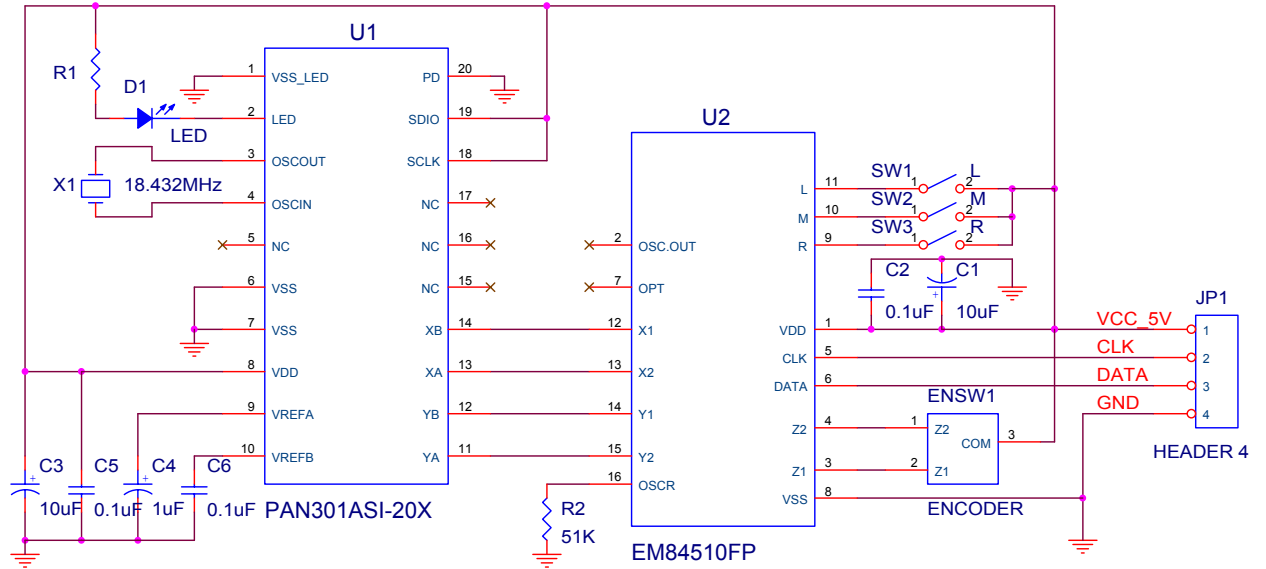

Figure 22. Application circuit using quadrature output with PAN301ASI-20X

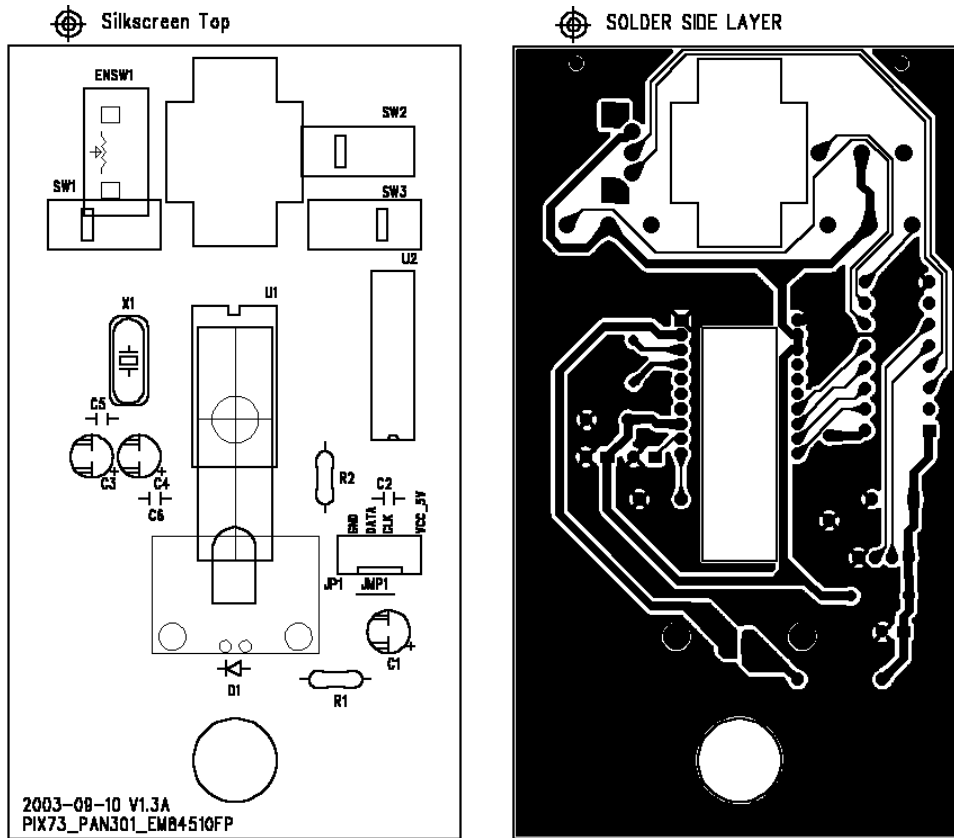

Figure 23. Example printed circuit board layout. (PAN301ASI-20X V.S EM84510FP)

#### 7.4 PCB Layout Consideration

1. Caps for pins 8, 9, 10 **MUST** have trace lengths **LESS** than **5mm**.
2. The trace lengths of OSCOUT, OSCIN must less than **6mm**.

#### 7.5 Recommended Value for R1

Radiometric intensity of LED  
Bin limits (mW/Sr at 20mA)

LED Bin grade	Min.	Typ.	Max.
N	14.7		17.7
P	17.7		21.2
Q	21.2		25.4

Note: Tolerance for each bin will be  $\pm 15\%$

R1 value (ohm), VDD=5.0V

LED bin grade	Min.	Typ.	Max.
N	51	100	
P	51	100	
Q	51	100	

## 8. Package Information

### 8.1 Package Outline Drawing

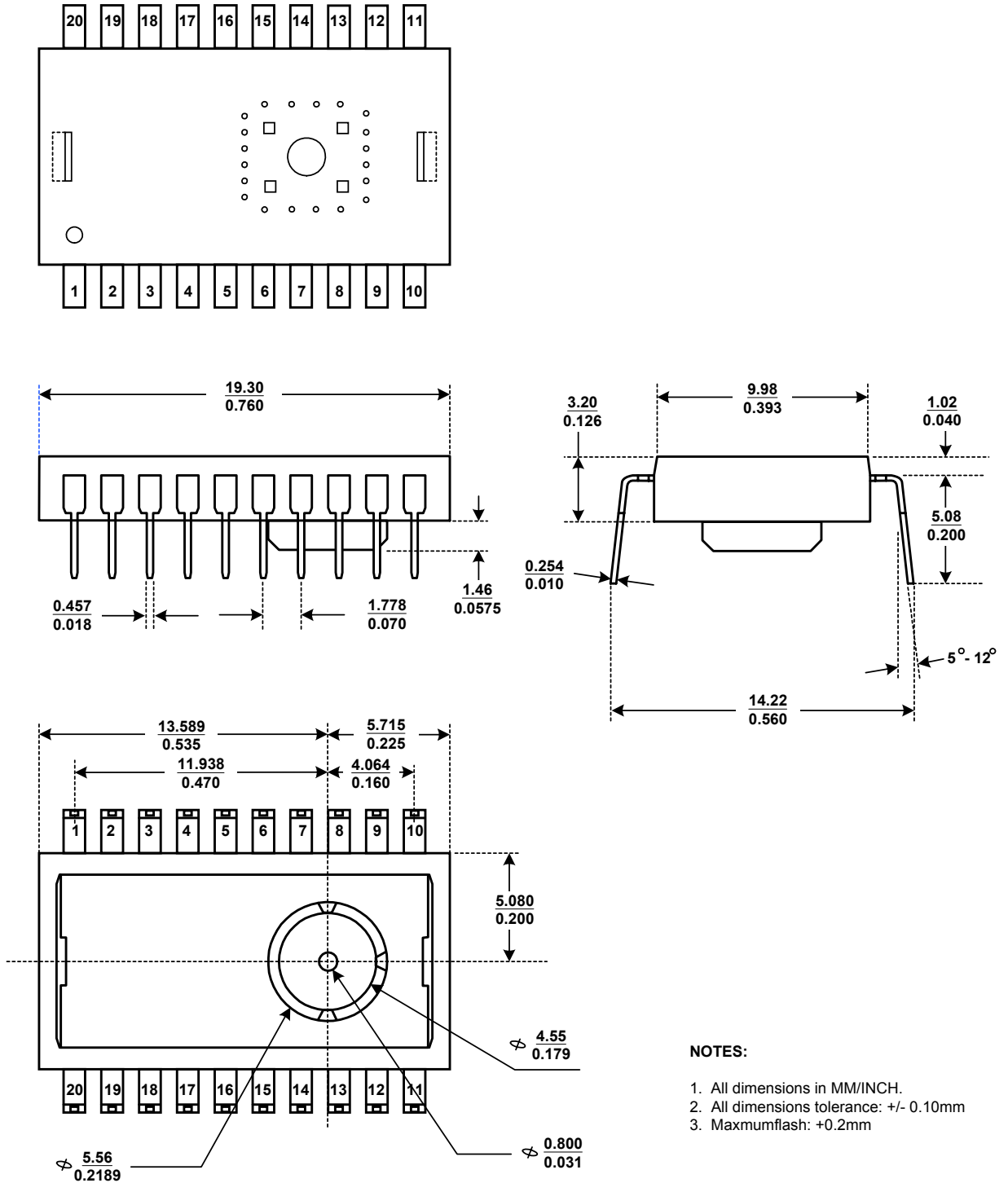

Figure 24. Package outline drawing

### 8.2 Recommended PCB Mechanical Cutouts and Spacing

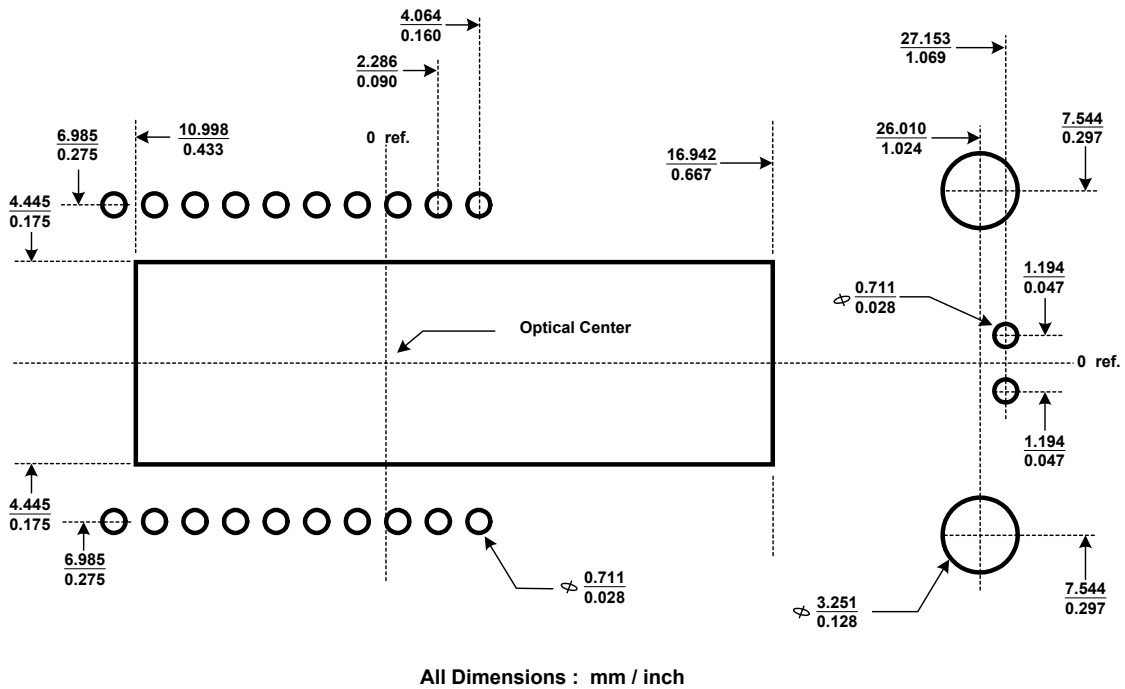

Figure 25. Recommended PCB mechanical cutouts and spacing

### 9. Update History

Version	Update	Date
V1.0	Creation, Preliminary 1 <sup>st</sup> version	10/27/2003
V1.1	3.2 Register Descriptions 4. Specifications - Recommend Operating Condition Figure5. 2D assembly 4. Specifications - DC Electrical Characteristics	01/12/2004
V1.2	3.2 Register Descriptions	01/14/2004
V1.3	3. Registers and Operation 4. Specifications - AC Operating Condition	05/06/2004