



Description

The ICS650-47 is a spread spectrum clock synthesizer intended for video projector applications. It generates an EMI optimized 50 MHz clock signal through the use of Spread Spectrum techniques from a 25 MHz crystal or clock input. For the 50 MHz output, the modulation rate is 50 kHz.

Features

- Packaged in 16-pin TSSOP (173 mil)
- Supply voltages: VDD = 3.3 V, VDDO = 2.5 V
- Peak-to-peak jitter: ± 125 ps typ
- Output duty cycle 45/55% (worst case)
- Guarantees +85°C operational condition
- 25 MHz crystal or reference clock input
- Zero (0) ppm frequency error on all output clocks
- Advanced, low-power CMOS process
- Industrial temperature range (0 to +85°C)

Block Diagram

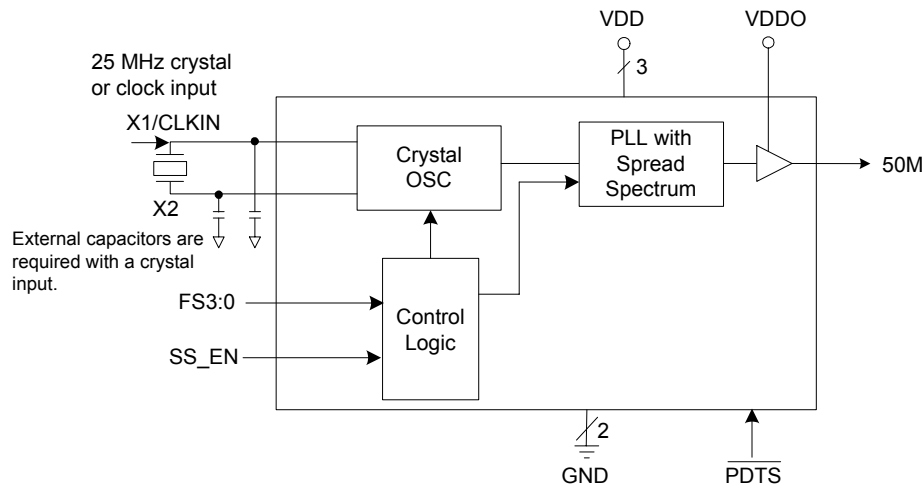



Pin Assignment

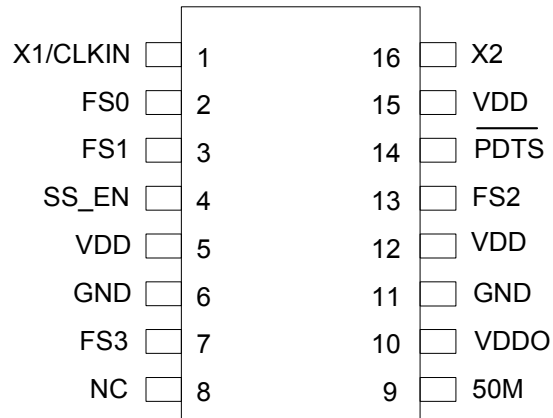

16-pin (173 mil) TSSOP

Spread Spectrum and Output Configuration Table

FS3	FS2	FS1	FS0	Spread Type	SS Out
0	0	0	0	Center	±0.25
0	0	0	1	Center	±0.50
0	0	1	0	Center	±0.75
0	0	1	1	Center	±1.00
0	1	0	0	Center	±1.25
0	1	0	1	Center	±1.50
0	1	1	0	Center	±1.75
0	1	1	1	Center	±2.00
1	0	0	0	Down	-0.5
1	0	0	1	Down	-0.75
1	0	1	0	Down	-1.0
1	0	1	1	Down	-1.25
1	1	0	0	Down	-1.5
1	1	0	1	Down	-1.75
1	1	1	0	Down	-2.0
1	1	1	1	Down	-2.25



Pin Descriptions

Pin Number	Pin Name	Pin Type	Pin Description
1	X1/CLKIN	Input	Crystal input. Connect this pin to a 25 MHz crystal or external input clock.
2	FS0	Input	Select pin 0. Internal pull-up resistor. See table on page 2.
3	FS1	Input	Select pin 1. Internal pull-up resistor. See table on page 2.
4	SS_EN	Input	Spread spectrum enable pin. Internal pull-up resistor. Enabled = high.
5	VDD	Power	Connect to +3.3 V.
6	GND	Power	Connect to ground.
7	FS3	Input	Select pin 3. Internal pull-up resistor. See table on page 2.
8	NC	—	No connect. No internal connection.
9	50M	Output	Spread Spectrum output. Weak internal pull-down when tri-stated.
10	VDDO	Power	Connect to +2.5 V.
11	GND	Power	Connect to ground.
12	VDD	Power	Connect to +3.3 V.
13	FS2	Input	Select pin 2. Internal pull-up resistor. See table on page 2.
14	PDTS	Input	Powers down entire chip. Tri-states CLK outputs when low. Internal pull-up.
15	VDD	Power	Connect to +3.3 V.
16	X2	Output	Crystal Output. Connect this pin to a 25 MHz crystal. Do not connect if clock input is used.

External Components

Decoupling Capacitor

As with any high-performance mixed-signal IC, the ICS650-47 must be isolated from system power supply noise to perform optimally.

A decoupling capacitor of 0.01 μ F must be connected between each VDD and the PCB ground plane.

Series Termination Resistor

Clock output traces over one inch should use series termination. To series terminate a 50 Ω trace (a commonly used trace impedance), place a 33 Ω resistor in series with the clock line, as close to the clock output pin as possible. The nominal impedance of the clock output is 20 Ω .

Crystal Load Capacitors

The device crystal connections should include pads for small capacitors from X1 to ground and from X2 to ground. These capacitors are used to adjust the stray capacitance of the board to match the nominally required crystal load capacitance. Because load capacitance can only be increased in this trimming process, it is important to keep stray capacitance to a minimum by using very short PCB traces (and no vias) between the crystal and device. Crystal capacitors must be connected from each of the pins X1 and X2 to ground.

The value (in pF) of these crystal caps should equal $(C_L - 6 \text{ pF}) * 2$. In this equation, C_L = crystal load capacitance in pF. Example: For a crystal with a 16 pF load capacitance, each crystal capacitor would be 20 pF $[(16-6) \times 2] = 20$.



PCB Layout Recommendations

For optimum device performance and lowest output phase noise, the following guidelines should be observed.

- 1) The 0.01 μ F decoupling capacitors should be mounted on the component side of the board as close to the VDD pin as possible. No vias should be used between the decoupling capacitors and VDD pins. The PCB trace to VDD pins should be kept as short as possible, as should the PCB trace to the ground via.
- 2) The external crystal should be mounted just next to the device with short traces. The X1 and X2 traces

should not be routed next to each other with minimum spaces, instead they should be separated and away from other traces.

- 3) To minimize EMI, the 33 Ω series termination resistor (if needed) should be placed close to the clock output.
- 4) An optimum layout is one with all components on the same side of the board, minimizing vias through other signal layers. Other signal traces should be routed away from the ICS650-47. This includes signal traces just underneath the device, or on layers adjacent to the ground plane layer used by the device.

Absolute Maximum Ratings

Stresses above the ratings listed below can cause permanent damage to the ICS650-47. These ratings, which are standard values for ICS commercially rated parts, are stress ratings only. Functional operation of the device at these or any other conditions above those indicated in the operational sections of the specifications is not implied. Exposure to absolute maximum rating conditions for extended periods can affect product reliability. Electrical parameters are guaranteed only over the recommended operating temperature range.

Item	Rating
Supply Voltage, VDD	5 V
All Inputs and Outputs	-0.5 V to VDD+0.5 V
Ambient Operating Temperature	0 to +85°C
Storage Temperature	-65 to +150°C
Junction Temperature	125°C
Soldering Temperature (max. of 10 seconds)	260°C

Recommended Operation Conditions

Parameter	Min.	Typ.	Max.	Units
Ambient Operating Temperature	0		+85	°C
Power Supply Voltage (measured in respect to GND)	+3.135	+3.3	+3.465	V
Power Supply Voltage (VDDO)	+2.375	+2.5	+2.625	V
Power Supply Ramp Time, Figure 4			4	ms



DC Electrical Characteristics

Unless stated otherwise, $V_{DD} = 3.3\text{ V} \pm 5\%$, $V_{DDO} = 2.5\text{ V} \pm 5\%$, Ambient Temperature 0 to +85°C

Parameter	Symbol	Conditions	Min.	Typ.	Max.	Units
Operating Supply Current	IDD	no load		27		mA
		$\overline{PDTS} = 0$, no load		40		μA
	IDDO	no load		4		mA
		$\overline{PDTS} = 0$, no load		1		μA
Input High Voltage	V_{IH}	FS3:0, \overline{PDTS} , SS_EN	2			V
Input Low Voltage	V_{IL}	FS3:0, \overline{PDTS} , SS_EN			0.8	V
Input High Voltage	V_{IH}	X1/CLKIN	0.7 x VDD			V
Input Low Voltage	V_{IL}	X1/CLKIN			0.3 x VDD	V
Output High Voltage	V_{OH}	$I_{OH} = -4\text{ mA}$	1.8			V
Output Low Voltage	V_{OL}	$I_{OL} = 4\text{ mA}$			0.6	V
Short Circuit Current	I_{OS}			± 50		mA
Nominal Output Impedance	Z_O			20		Ω
Internal Pull-up Resistor	R_{PU}	FS3:0, \overline{PDTS} , SS_EN		360		k Ω
Input Leakage Current	I_I	FS3:0, \overline{PDTS} , SS_EN, VIN=VDD		1		μA
Internal Pull-down Resistor	R_{PD}	CLK output		900		k Ω
Input Capacitance	C_{IN}	Inputs		4		pF



AC Electrical Characteristics

Unless stated otherwise, $V_{DD} = 3.3\text{ V} \pm 5\%$, $V_{DDO} = 2.5\text{ V} \pm 5\%$, Ambient Temperature 0 to $+85^{\circ}\text{C}$

Parameter	Symbol	Conditions	Min.	Typ.	Max.	Units
Input Frequency	F_{IN}	Crystal or clock input		25		MHz
Spread Spectrum Modulation Frequency				50		kHz
Duty Cycle	t_2/t_1	At $V_{DD}/2$, Note 1 and Figures 1 and 2	45	50	55	%
Output Fall Time	t_3	80% to 20%, Note 1 and Figures 1 & 3		1.5		ns
Output Rise Time	t_4	20% to 80%, Note 1 and Figures 1 & 3		1.5		ns
One Sigma Clock Period Jitter		Note 1		30		ps
Absolute Jitter, Peak-to-Peak	t_{ja}	Deviation from mean, $SS_EN=0$, Note1 & Figures 1 and 6		± 125		ps
Output Enable Time	t_{EN}	$\overline{PDT\overline{S}}$ high to PLL locked to within 1% of final value, Figure 5		2.5	5	ms
Output Disable Time	t_{DIS}	$\overline{PDT\overline{S}}$ low to tri-state, Figure 5		20		ns
Power-up Time	t_P	PLL lock-time from power-up to 1% of final value, Figure 4		6	10	ms

Note 1: Measured with 15 pF load.



Thermal Characteristics

Parameter	Symbol	Conditions	Min.	Typ.	Max.	Units
Thermal Resistance Junction to Ambient	θ_{JA}	Still air		78		°C/W
	θ_{JA}	1 m/s air flow		70		°C/W
	θ_{JA}	3 m/s air flow		68		°C/W
Thermal Resistance Junction to Case	θ_{JC}			37		°C/W

Marking Diagram

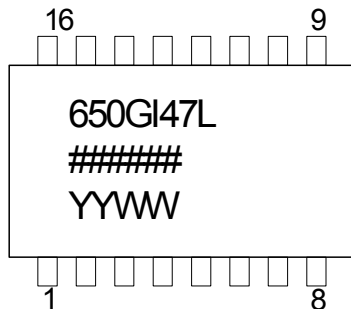

Notes:

1. ##### is the lot number.
2. YYWW is the last two digits of the year and the week number that the part was assembled.
3. "L" designates Pb (lead) free package
4. Bottom marking: country of origin if not USA.



Timing Diagrams

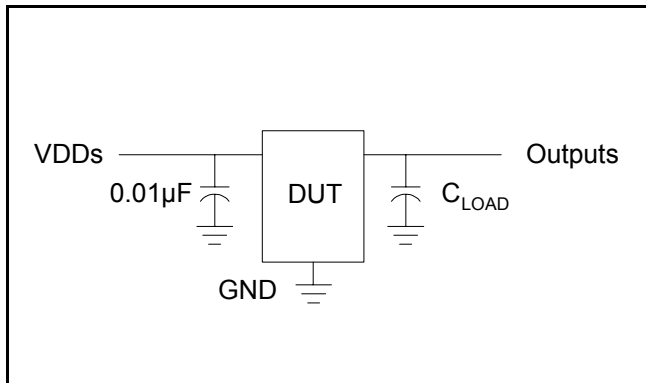

Figure 1: Test and Measurement Setup

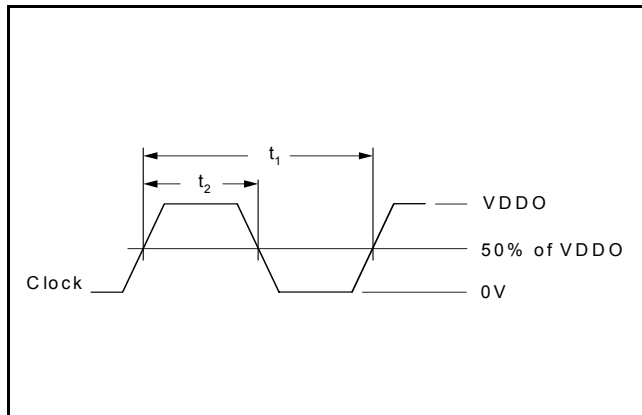

Figure 2: Duty Cycle Definitions

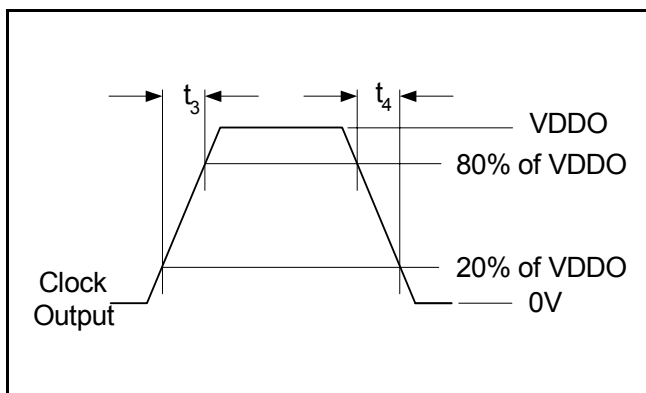

Figure 3: Rise and Fall Time Definitions

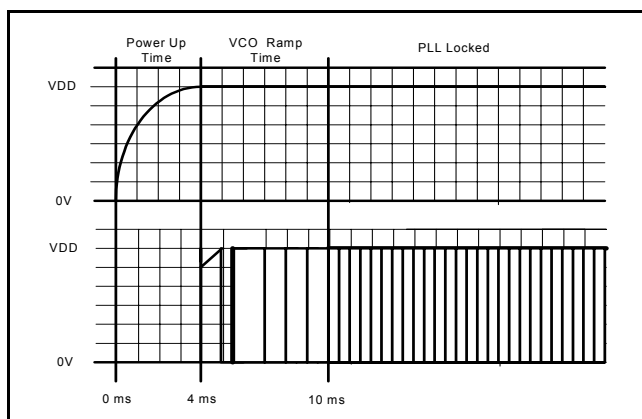

Figure 4: Power Up and PLL Lock Timing

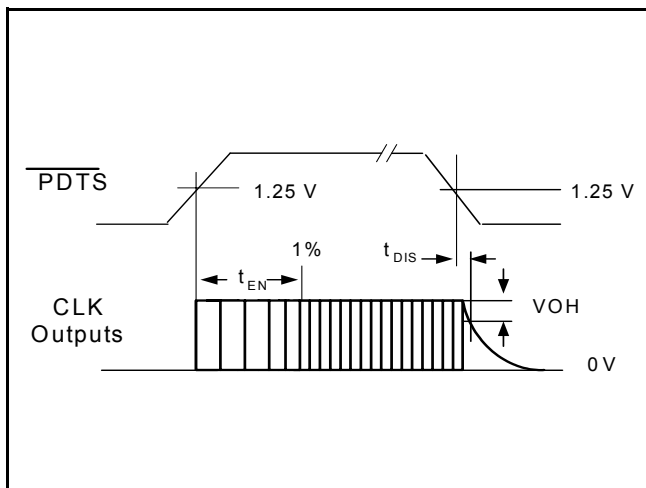

Figure 5: PDS to Stable Clock Output Timing

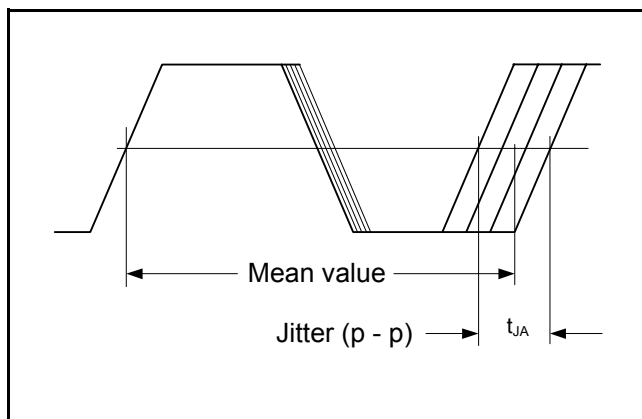
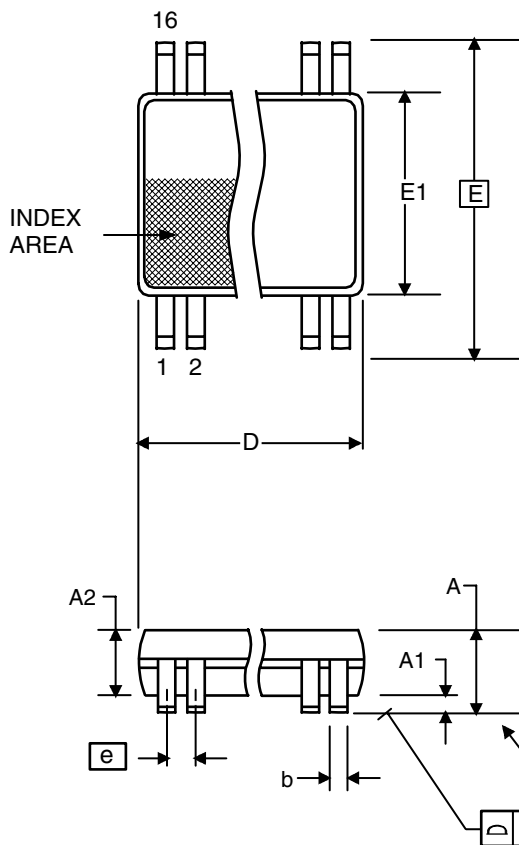

Figure 6: Short Term Jitter Definition

**Package Outline and Package Dimensions (16-pin TSSOP, 173 Mil. Narrow Body)**

Package dimensions are kept current with JEDEC Publication No. 95

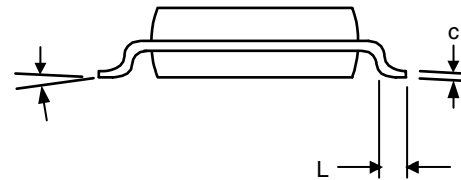

Symbol	Millimeters		Inches	
	Min	Max	Min	Max
A	--	1.20	--	0.047
A1	0.05	0.15	0.002	0.006
A2	0.80	1.05	0.032	0.041
b	0.19	0.30	0.007	0.012
C	0.09	0.20	0.0035	0.008
D	4.90	5.1	0.193	0.201
E	6.40 BASIC		0.252 BASIC	
E1	4.30	4.50	0.169	0.177
e	0.65 Basic		0.0256 Basic	
L	0.45	0.75	0.018	0.030
α	0°	8°	0°	8°
aaa	--	0.10	--	0.004

**Ordering Information**

Part / Order Number	Marking	Shipping Packaging	Package	Temperature
ICS650GI-47LF	650GI47L	Tubes	16-pin TSSOP	0 to +85° C
ICS650GI-47LFT	650GI47L	Tape and Reel	16-pin TSSOP	0 to +85° C

Parts that are ordered with a "LF" suffix to the part number are the Pb-Free configuration and are RoHS compliant.

While the information presented herein has been checked for both accuracy and reliability, Integrated Circuit Systems (ICS) assumes no responsibility for either its use or for the infringement of any patents or other rights of third parties, which would result from its use. No other circuits, patents, or licenses are implied. This product is intended for use in normal commercial applications. Any other applications such as those requiring extended temperature range, high reliability, or other extraordinary environmental requirements are not recommended without additional processing by ICS. ICS reserves the right to change any circuitry or specifications without notice. ICS does not authorize or warrant any ICS product for use in life support devices or critical medical instruments.



Revision History

Rev.	Originator	Date	Description of Change
A	P.Griffith	8/11/05	New device.