

# 2.00mm (0.079") PITCH CONNECTOR



**Board-to-Board  
Housing**

**20045HS Series**

**SMT(Dual Sided Contact Type)**

**Straight**

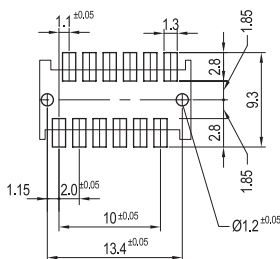
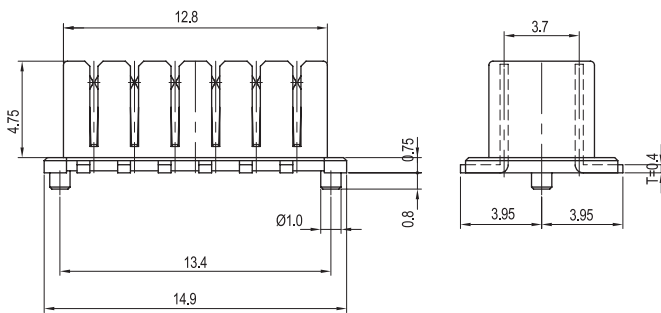
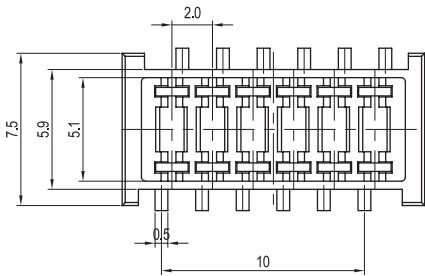
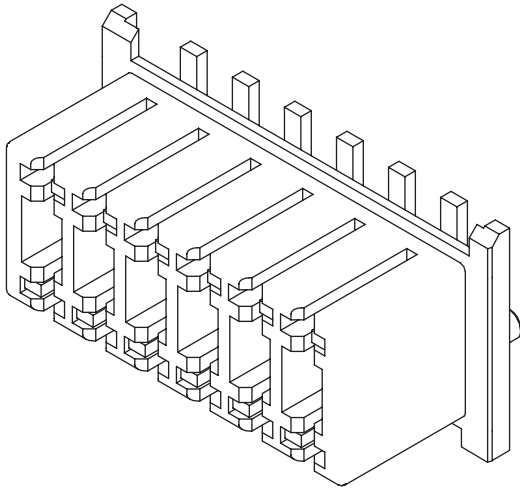

**P,C,B LAYOUT**

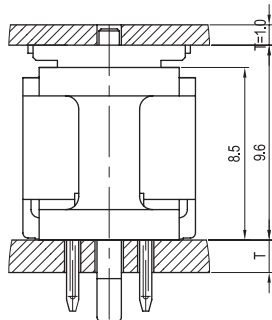

**MATING WITH**

## Material

I/NO	DESCRIPTION	TITLE	MATERIAL
1	WAFER	20045HS	PA6T or PA46, UL 94V Grade
2	PIN	20045TS	Phosphor Bronze & Tin-Plated

## Available Pin

PARTS NO.	A	B	C	D
20045HS-08A00	10.9	9.4	6.0	8.8
20045HS-10A00	12.9	11.4	8.0	10.8
20045HS-12A00	14.9	13.4	10.0	12.8

## Specification

ITEM	SPEC
Voltage Rating	AC/DC 250V
Current Rating	AC/DC 1A
Operating Temperature	-25°C~+85°C
Contact Resistance	30mΩ MAX
Withstanding Voltage	AC500V/1min
Insulation Resistance	1000MΩ MIN
Applicable Wire	-
Applicable P.C.B	0.8~1.6mm
Applicable FPC/FFC	-
Solder Height	0.15mm
Crimp Tensile Strength	-
UL FILE NO	-