

LSI53C1000R ULTRA160 SCSI CONTROLLER



PCI-SINGLE CHANNEL ULTRA160 SCSI CONTROLLER OVERVIEW

The LSI53C1000R PCI-Single Channel Ultra160 SCSI Controller provides a low-risk upgrade path to Ultra320 SCSI and to PCI-X. Because the LSI53C1000R is packaged in the same BGA as the LSI53C1020 PCI-X to Single Channel Ultra320 SCSI Controller, a motherboard can be designed now to accept either part without the need for redesign. The LSI53C1000R is identical in function to the proven LSI53C1000 PCI-Single Channel Ultra160 SCSI Controller.

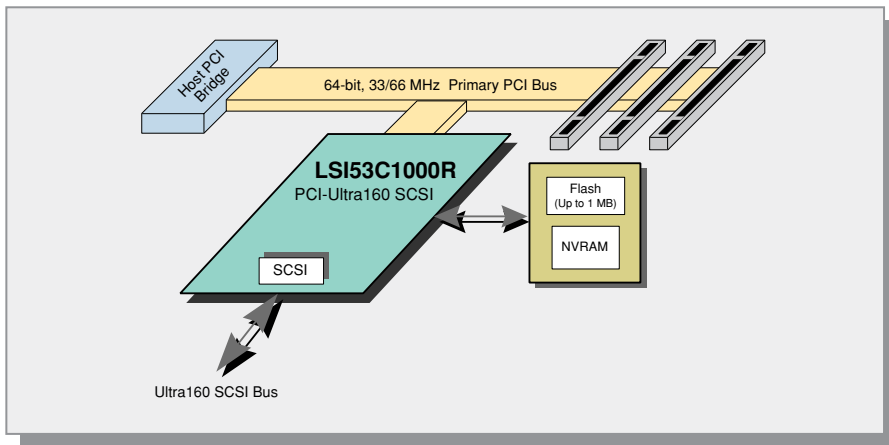

Figure 1. SCSI on the motherboard

KEY APPLICATIONS

- Servers – Internet/Intranet network, video, e-mail, printing, database management, and financial applications
- Workstations – CAD/CAM, industrial simulation, etc.
- Host attach for RAID and JBOD mass storage subsystems – Anywhere data access is the bottleneck

BENEFITS

- Provides a low-risk upgrade path to next level of performance
- Paves the way to Ultra320 SCSI by being pin compatible with the LSI53C1020 PCI-X to Single Channel Ultra320 SCSI Controller
- Allows you to design one board for present and future technologies
- Preserves SCSI investment
- Reduces time to market
- Provides complete end-to-end protection of the SCSI I/O with Cyclic Redundancy Check (CRC) and Asynchronous Information Protection (AIP)
- Provides robust performance with SureLINK™ domain validation
- Supports all major operating systems



The
Communications
Company™

LSI53C1000R Ultra160 SCSI Controller

FEATURES

- Pin compatible with LSI53C1020 Ultra320 controller
 - Functionally identical to LSI53C1000 Ultra160 controller
- No external memory required
- 64-bit, 33/66 MHz PCI interface
 - Theoretical 528 MBps zero wait state transfer rate
 - 64-bit addressing supported through Dual Address Cycle (DAC)
- Compliant with PCI 2.2, PCI Power Management 1.1 and PC99
- Supports Ultra160 SCSI
 - Double transition clocking for 160 MBps throughput
 - CRC
 - Domain validation
- Comprehensive SureLINK domain validation
 - Basic (Level 1) with inquiry command
 - Enhanced (Level 2) with read/write buffer
 - Margined (Level 3) with margining of LVD drive strength and programmable skew test

ULTRA160 SCSI FEATURES

Double transition clocking enables throughput of up to 160 MBps without increasing the interface clock rate.

Cyclic Redundancy Check (CRC) improves the reliability of SCSI data transmission through enhanced detection of communication errors. CRC provides extra data protection for marginal cable plants and external devices. CRC is the best way to ensure data protection during hot plugging. It uses the same proven CRC algorithm used by FDDI, Ethernet, and Fibre Channel, and detects all single bit errors, all double bit errors, all odd number of errors, and all burst errors up to 32 bits long. To provide complete end-to-end protection of the SCSI I/O, AIP protects all non-data phases, augmenting the CRC feature of Ultra160.

SureLINK domain validation technology detects the configuration of the SCSI bus and automatically tests and adjusts the SCSI transfer rate to optimize interoperability. The LSI53C1000R exceeds Ultra160 by providing not only Basic (Level 1) and Enhanced (Level 2) domain validation, but adds Margined (Level 3) domain validation. This enhancement margins LVD drive strength and clock signal timing characteristics to identify marginal Ultra160 systems.

HARDWARE/SOFTWARE OVERVIEW

PCI Interface

The host PCI interface complies with PCI Local Bus Specification Revision 2.2, and implements a 64-bit/66 MHz PCI bus. It is backward compatible with 32-bit/33 MHz buses. Additionally, support for DAC is provided.

The LSI53C1000R complies with PCI Power Management Interface Specification Revision 1.1 and PC 99, supporting power states D0, D1, D2, D3hot and D3cold, power management capabilities registers, and programmable values for PCI Subsystem Vendor ID and Subsystem ID. Extended access cycles (Memory Read Line, Memory Read Multiple, and Memory Write and Invalidate) are also supported.

SCSI Processor

The LSI53C1000R supports wide Ultra160 SCSI synchronous transfer rates up to 160 MBps on a LVD SCSI bus. Integrated LVDlink™ transceivers support both LVD and single-ended signals with no external transceivers required. Fast SCSI, Ultra SCSI, Ultra2 SCSI, and Ultra160 SCSI are all supported by the LSI53C1000R.

An on-chip SCSI clock quadrupler allows the chip to achieve Ultra160 SCSI transfer rates with an input frequency of 40 MHz. The 8 KB of internal RAM for SCRIPTS™ instruction storage allow all accesses to remain internal, reducing the time spent on the PCI bus. A 944-byte DMA FIFO allows the device to efficiently burst up to 512 bytes across the PCI bus. SCSI bus phase mismatches are handled in SCRIPTS, reducing CPU utilization.

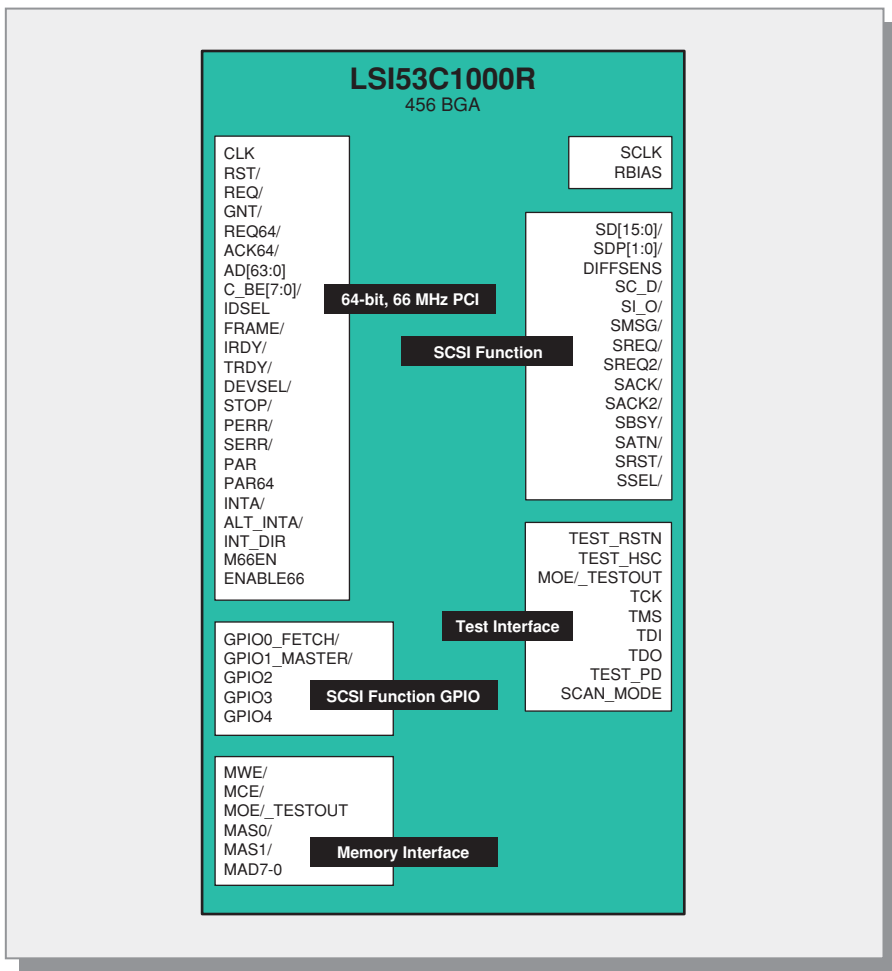

Figure 2. LSI53C1000R functional signal grouping

MEMORY INTERFACES

The LSI53C1000R supports up to 1 MB of external expansion ROM through a parallel interface, for add-in card designs. For ease of software development and field upgrades of the ROM, the interface supports local programming of FLASH memory. A serial 2-wire interface provides a connection to an external serial EEPROM for storing Subsystem Vendor ID and Subsystem ID.

FEATURES (Continued)

- AIP
 - Covers all non-data, including command, status and messages
- One wide Ultra160 SCSI channel
- SCSI Interrupt Steering Logic (SISL) alternate interrupt routing for RAID applications
- Proven integrated LVDlink transceivers for direct attach to either Low Voltage Differential (LVD) or single-ended (SE) SCSI buses
- IEEE 1149.1 JTAG boundary scan
- Flash and local memory interface
- Packaged in a 456 BGA
- Supported in Storage Device Management System (SDMS™) software
 - Full operating system support:
 - Windows® NT® 4.0, 95/98 and 2000
 - Linux™
 - Solaris™
 - UnixWare™
 - Novell® NetWare®
 - OS/2
- Server Management CI (component instrumentation)

LSI53C1000R Ultra160 SCSI Controller

SOFTWARE

The LSI53C1000R is supported with the proven SDMS software. SDMS software enables the performance enhancements of Ultra160 data transfer speed increases and improved PCI bus utilization capabilities included in the LSI53C1000R. The LSI53C1000R reliability capabilities of AIP and CRC are enabled and managed by the SDMS software. SDMS software implements the manageability improvements of the LSI Logic SureLINK domain validation technology. SureLINK technology extends standard domain validation with the addition of full cable plant margining. The cable plant margining capability, exclusive to LSI Logic's Ultra160 solution, includes end-to-end margining from the LSI53C1000R through LSI Logic's LSI53C180 SCSI bus expander to the target device. The domain validation capability of SDMS software is available as an independent application as well as integrated in the DMI 2.0 based system management solution for enterprise class implementations. SDMS software includes BIOS and OSV certified drivers for all major operating systems including DOS with ASPI support, Windows 95/98, Windows NT/2000, UnixWare, OS/2, NetWare, Solaris, and Linux. A complete set of SCSI utilities rounds out the software solution, which includes a DMI 2.0 based system management software for Windows NT, NetWare, UnixWare, Solaris and Linux, and a stand-alone or snap-in DMI browser applet and SureLINK applet.

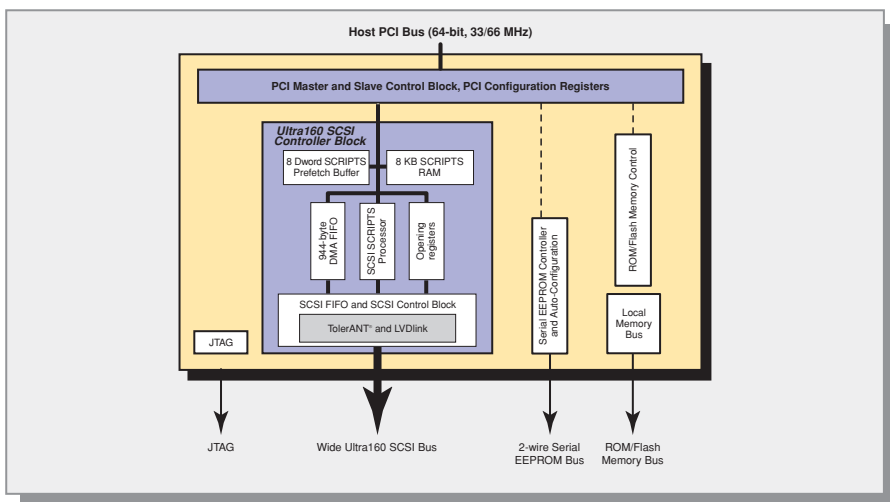

Figure 3. LSI53C1000R functional block diagram

For more information please visit the LSI Logic web site at:

<http://storageio.lsillogic.com>

LSI Logic Corporation

North American Headquarters
Milpitas, CA

Tel: 866 574 5741

LSI Logic Europe Ltd.

European Headquarters
United Kingdom

Tel: 44 1344 426544

Fax: 44 1344 481039

LSI Logic KK Headquarters

Tokyo, Japan

Tel: 81 3 5463 7165

Fax 81 3 5463 7820

ISO 9000 Certified

LSI Logic logo design and TolerANT are registered trademarks, and LVDlink, SCRIPTS, SDMS, and SureLINK are trademarks of LSI Logic Corporation. All other brand and product names may be trademarks of their respective companies.

LSI Logic Corporation reserves the right to make changes to any products and services herein at any time without notice. LSI Logic does not assume any responsibility or liability arising out of the application or use of any product or service described herein, except as expressly agreed to in writing by LSI Logic; nor does the purchase, lease, or use of a product or service from LSI Logic convey a license under any patent rights, copyrights, trademark rights, or any other of the intellectual property rights of LSI Logic or of third parties.

Copyright ©2001 by LSI Logic Corporation.
All rights reserved.

Order No. S20036
7/01-1M – Printed in USA



The
Communications
Company™