

GENERAL DESCRIPTION

The SM5021A/B is a high performance infrared remote control encoder utilizing CMOS technology. Mode A is a signal-key control and mode B is a multi-key control during data transmission, supports eight data key inputs and a LED output to indicate the status during transmission.

Auto power off function when key is not pressed to save power, custom codes to distinguish different products. SM5021 encoder is paired with SM5032 decoder for more data control applications.

FEATURES

- * Wide operation voltage range, 2.4V to 6V
- * Eight data key control
- * Option of signal-key or multi-key control
- * Two custom codes to separate products
- * Auto power off for saving power
- * LED output to indicate transmission status
- * Direct infrared LED 38KHz modulation output
- * Low power consumption
- * Paired with SM5032 decoder
- * 16 pin DIP or SO package

APPLICATIONS

- * SM3015 Fan Remote Control
- * Audio Remote Control
- * Toy Remote Control
- * Consumer Products Remote Control

PIN ASSIGNMENT (TOP VIEW)

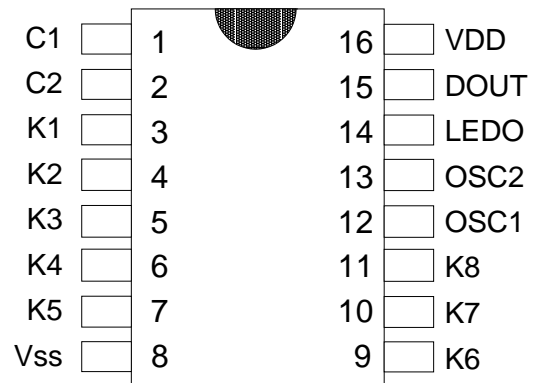

SM5021A/B

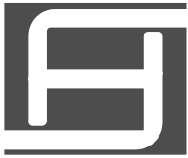

BLOCK DIAGRAM

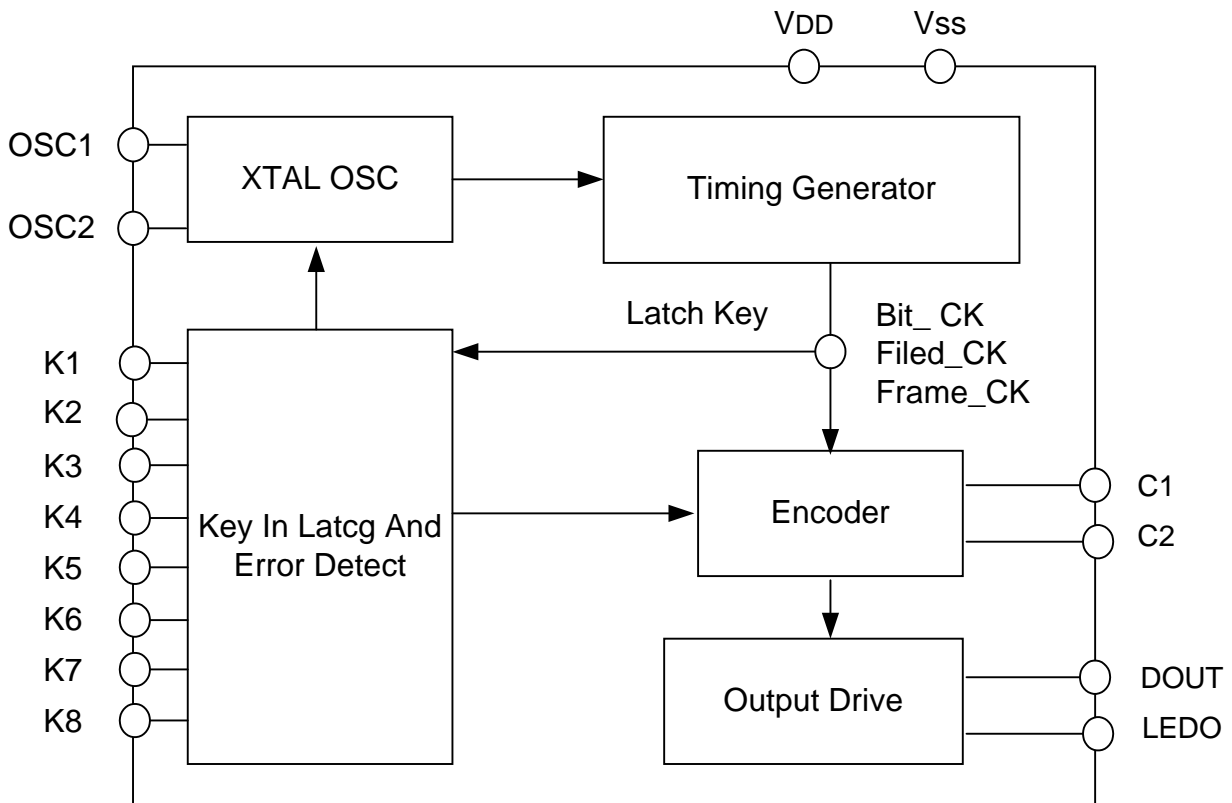

PIN DESCRIPTION

Pin Name	I / O	Function
C1,C2	I	Custom Code
K1 ~ K8	I	Remote Control Key Inputs (Built-In Pull-Low Resistor)
Vss	POWER	Negative Power Supply (Substrate)
OSC1	I	455KHz XTAL OSC Pin
OSC2	O	455KHz XTAL OSC Pin
DOUT	O	Signal Output
LEDO	O	Transmission Indicator
VDD	POWER	Positive Power Supply



C. Transmission Timing

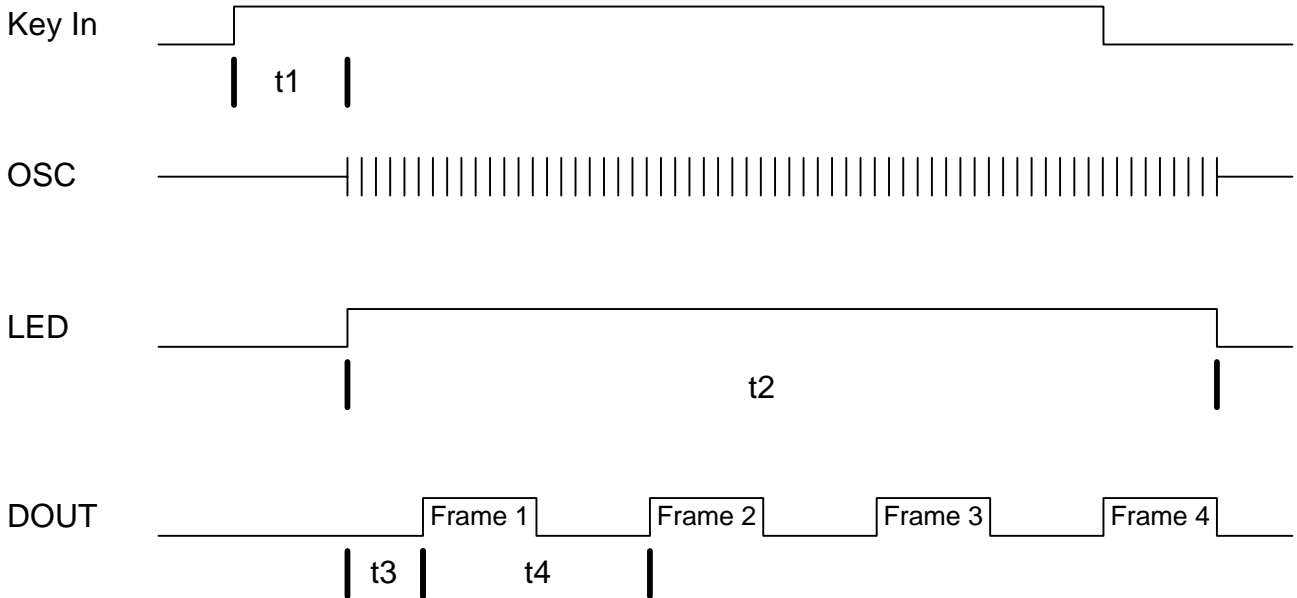

* t1: Key pressing > 32ms

* t2: Transmission time $t_3 + 108\text{ms}$ (Four frame)
If t1 is over $t_3 + 108\text{ms}$, DOUT will be transmitted again.
 $[(\text{Pressing time}) \text{MOD} (t_3 + 108\text{ms}) + 1] * 108\text{ms} + t_3$

* t3: Oscillator stable time. $\text{OSC} * 384 = 0.8\text{ms}$

* t4: 3-Bits(Head) + 2-Bits(Custom Code) + 7-Bits(Data) + 6-Bits(Empty) = 18-Bits (27ms)

* OSC: 455KHz resonator



D. SM5021A Transmission Waveform

Normal Condition

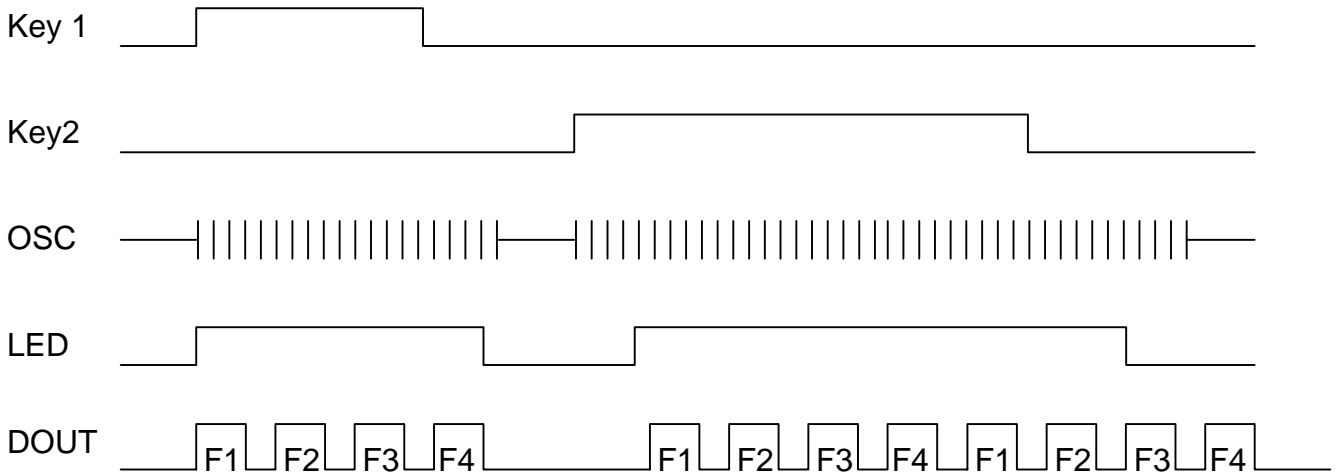

Overlap Condition

If more than one key is pressed, transmission stops.

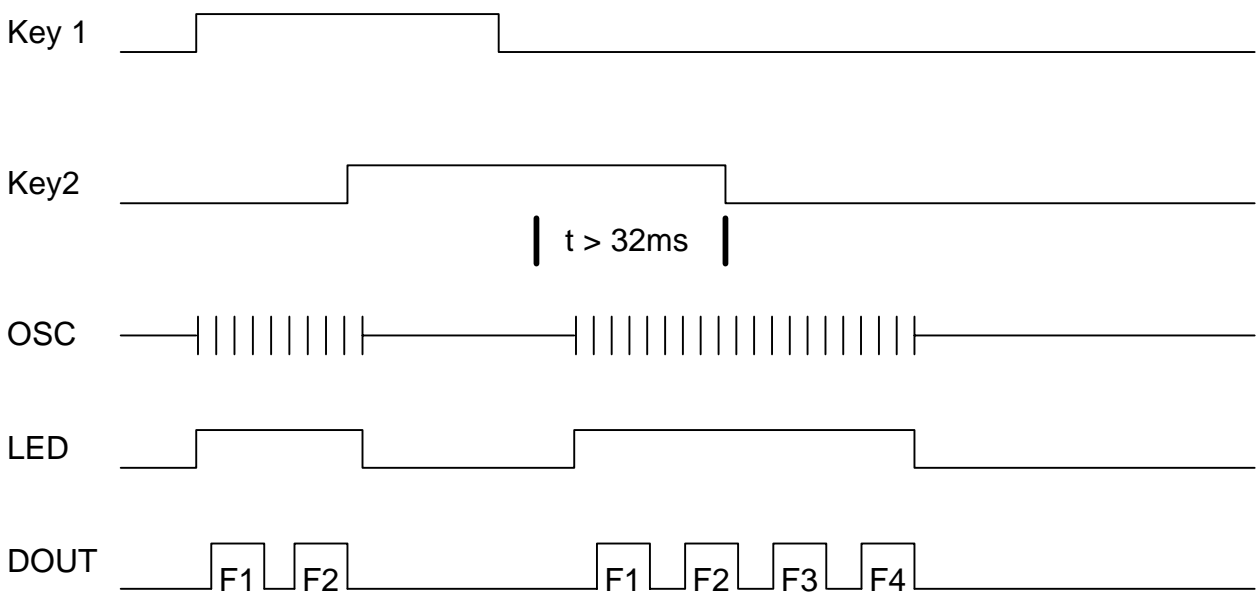



E. SM5021B Transmission Waveform

Normal Condition

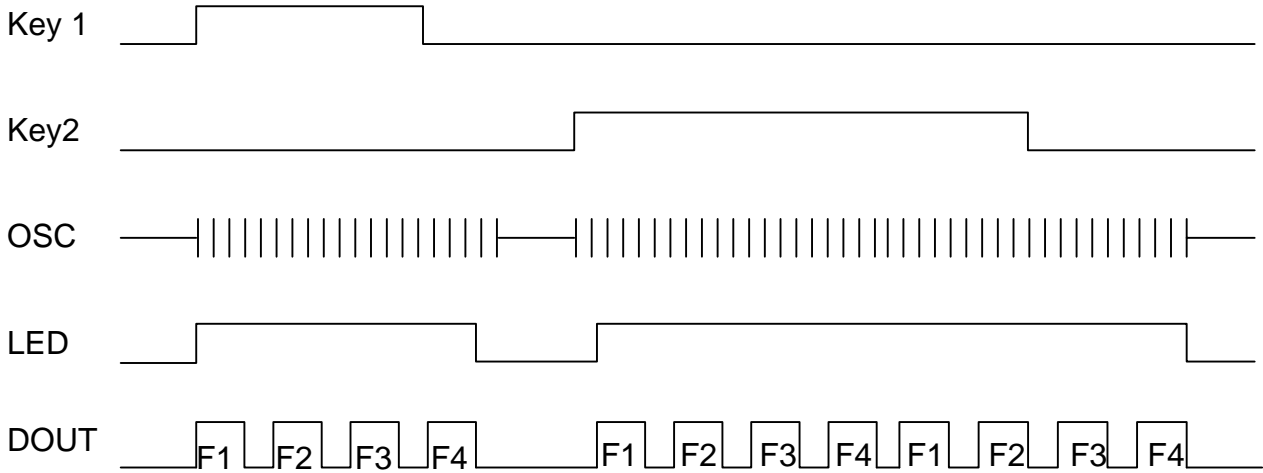

Overlap Condition

If more than one key is pressed, multi-key data transmission.

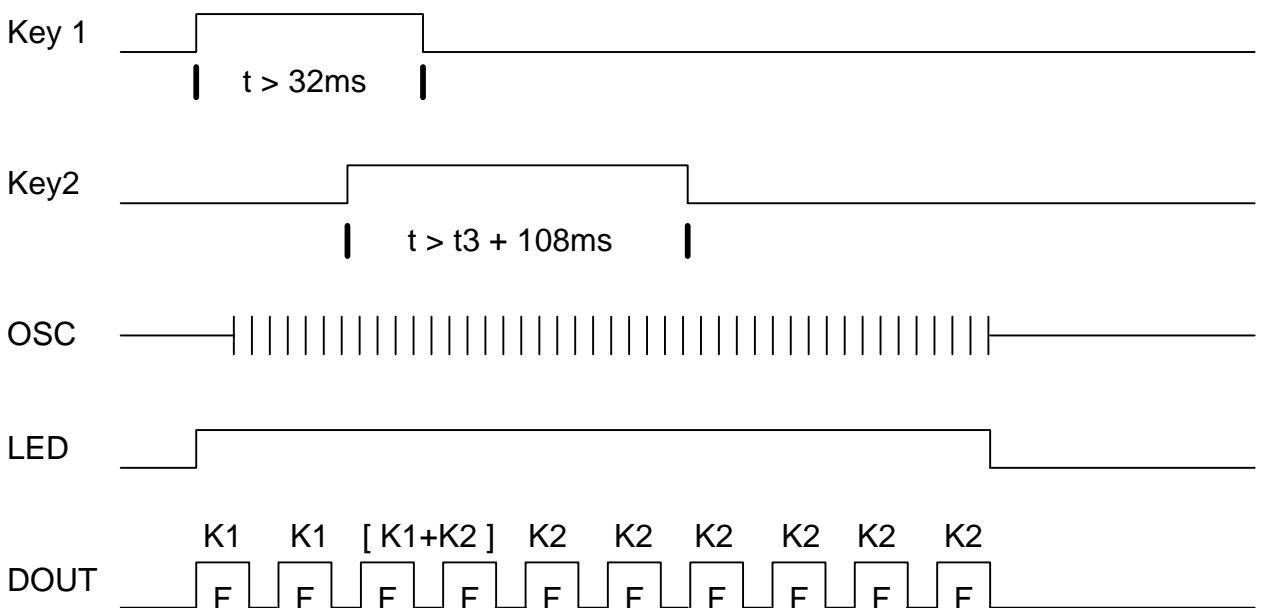



ABSOLUTE MAXIMUM RATINGS

Parameter	Symbol	Test Conditions	Ratings	Unit
Supply Voltage	VDD-Vss		-0.3 ~ 6	V
Input Voltage	VI		Vss -0.3 ~ VDD +0.3	V
Output Voltage	VO		Vss -0.3 ~ VDD +0.3	V
Maximum Power Consumption	Pa	VDD - Vss = 5V	500	mW
Operating Temperature	Topr		-10 ~ 70	
Storage Temperature	Tstg		-40 ~ 125	

DC ELECTRICAL CHARACTERISTICS

Parameter	Symbol	Conditions	Limit			Unit
			Min.	Typ.	Max.	
Supply Voltage	VDD		2.4	3	6	V
Stand-by Current	ISB	VDD - Vss = 3V OSC stop all output pins open		1		μA
Input High Level	VIH		1.5		3.5	V
Input Low Level	VIL		0		1.5	V
DOUT Source Current	IOH	VOH = +2.4V			5	mA
LEDO Source Current	IOH	VOH = +2.4V			7.5	mA
DOUT Sink Current	IOL	VOL = +0.4V			5	mA



APPLICATION CIRCUIT

