

GaAs MMIC

Data Sheet

CGY 93

- Power amplifier for GSM application
- 2 stage amplifier
- Overall power added efficiency 55%

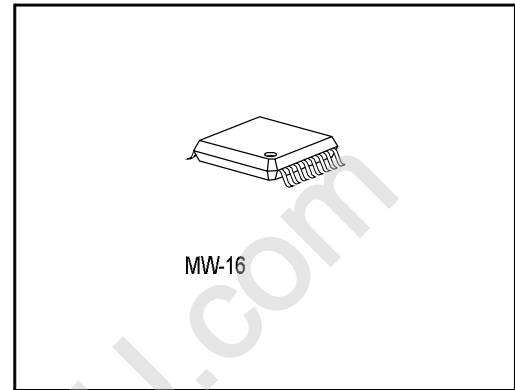

ESD: Electrostatic discharge sensitive device, observe handling precautions!

Type	Marking	Ordering Code (taped)	Package
CGY 93	CGY 93	t.b.d.	MW-16

Maximum Ratings	Symbol	Value	Unit
Positive supply voltage	V_D	7.0	V
Negative supply voltage	V_G	- 4.0	V
Supply current stage 1	I_{D1}	0.6	A
Supply current stage 2	I_{D2}	3.5	A
Channel temperature	T_{Ch}	150	°C
Storage temperature	T_{stg}	- 55 ... + 150	°C
RF input power	P_{in}	20	dBm
Total power dissipation (CW, $T_c \leq 83$ °C) T_c : Temperature at soldering point	P_{tot}	7.5	W
Pulse peak power dissipation duty cycle 12.5%, $t_{on} = 0.577$ ms	P_{Puls}	17	W

Thermal Resistance	Symbol	Value	Unit
Junction-Case	R_{thJCh}	9.0	K/W

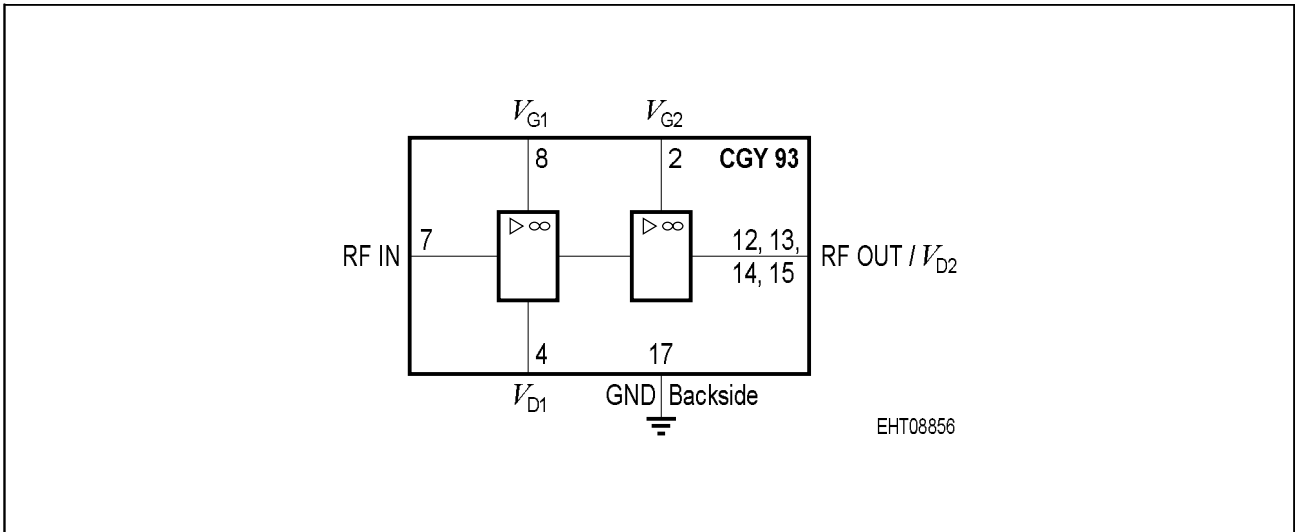

Figure 1 Functional Block Diagram

Pin Out

Pin #	Name	Configuration
1	NC	–
2	VG2	Gate voltage stage 2
3	NC	–
4	VD1	Drain Voltage stage 1
5	NC	–
6	NC	–
7	RFin	RF input
8	VG1	Gate Voltage stage 1
9	NC	–
10	NC	–
11	NC	–
12,13,14,15	VD2/RFout	Drain voltage stage 2/RF output
16	NC	–
(17)	GND	Ground (backside of MW-16 housing)

Electrical Characteristics

$T_A = 25\text{ }^\circ\text{C}$, pulsed with a duty cycle of 12.5%, $t_{\text{on}} = 577\text{ }\mu\text{s}$
 adjust $V_{G1} = V_{G2}$ for $I_{D0} = 1.6\text{ A}$ (I_{D0} : drain current without RF)

Parameters	Symbol	Limit Values			Unit	Test Conditions
		min.	typ.	max.		
Frequency range	f	880	–	915	MHz	–
Supply current without RF	I_{D0}	–	1.6	–	A	–
Supply current with RF	I_{DHF}	–	1.2	–	A	$P_{\text{in}} = 12\text{ dBm}$
Small signal gain	G	–	33.0	–	dB	$V_D = 2.8\text{ V}$, $P_{\text{in}} = -10\text{ dBm}$
Power gain	G_P	–	20.5	–	dB	$V_D = 2.8\text{ V}$, $P_{\text{in}} = 12\text{ dBm}$
Output Power	P_{out}	32.1	32.5	–	dBm	$V_D = 2.8\text{ V}$, $P_{\text{in}} = 12\text{ dBm}$
Output Power	P_{out}	34.0	34.5	–	dBm	$V_D = 3.5\text{ V}$, $P_{\text{in}} = 12\text{ dBm}$
Output Power	P_{out}	35.8	36.3	–	dBm	$V_D = 4.8\text{ V}$, $P_{\text{in}} = 12\text{ dBm}$
Overall Power added Efficiency	η	47	53	–	%	$V_D = 2.8\text{ V}$, $P_{\text{in}} = 12\text{ dBm}$
Overall Power added Efficiency	η	50	55	–	%	$V_D = 3.5\text{ V}$ or $V_D = 4.8\text{ V}$, $P_{\text{in}} = 12\text{ dBm}$
Noise Power in RX (935 - 960 MHz)	N_{RX}	–	– 80	–	dBm	$P_{\text{in}} = 12\text{ dBm}$, $P_{\text{out}} = 32.5\text{ dBm}$, 100 kHz RBW
Harmonics	$H(2f_0)$ $H(3f_0)$	40 40	43 43	– –	dBc	$V_D = 2.8\text{ V}$, $P_{\text{in}} = 10\text{ dBm}$, $P_{\text{out}} = 32.5\text{ dBm}$
Stability all spurious outputs < – 60 dBc, VSWR load, all phase angles	–	–	10 : 1	–	–	–
Input VSWR	–	–	2 : 1	2.2 : 1	–	$V_D = 2.8\text{ V}$

CGY 93, @ 2.8 V, $f = 900$ MHz

$V_G = -2.1$ V, pulsed with a duty cycle of 12.5%, $t_{on} = 0.577$ ms

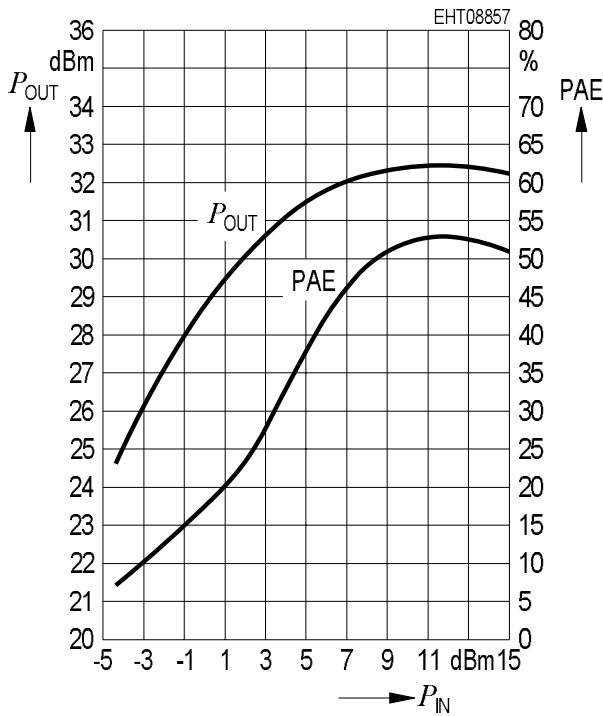

CGY 93, @ 4.8 V, $f = 900$ MHz

$V_G = -2.1$ V, pulsed with a duty cycle of 12.5%, $t_{on} = 0.577$ ms

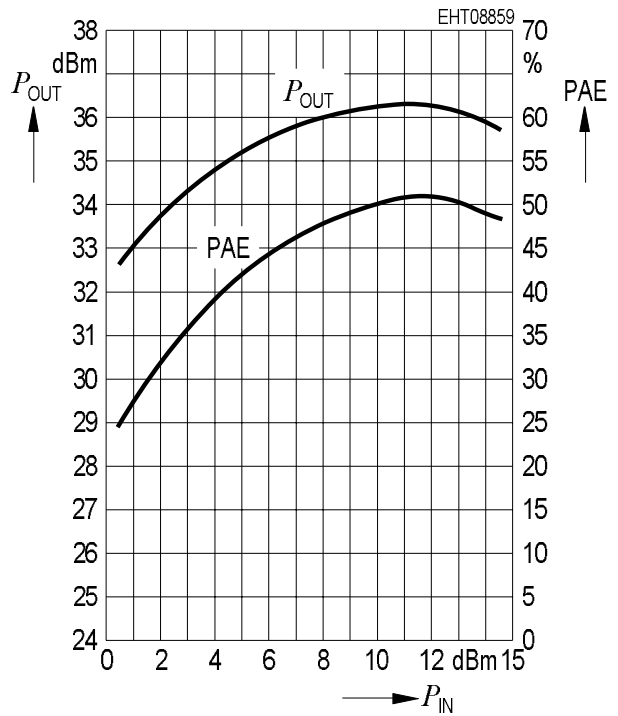

CGY 93, @ 3.5 V, $f = 900$ MHz

$V_G = -2.1$ V, pulsed with a duty cycle of 12.5%, $t_{on} = 0.577$ ms

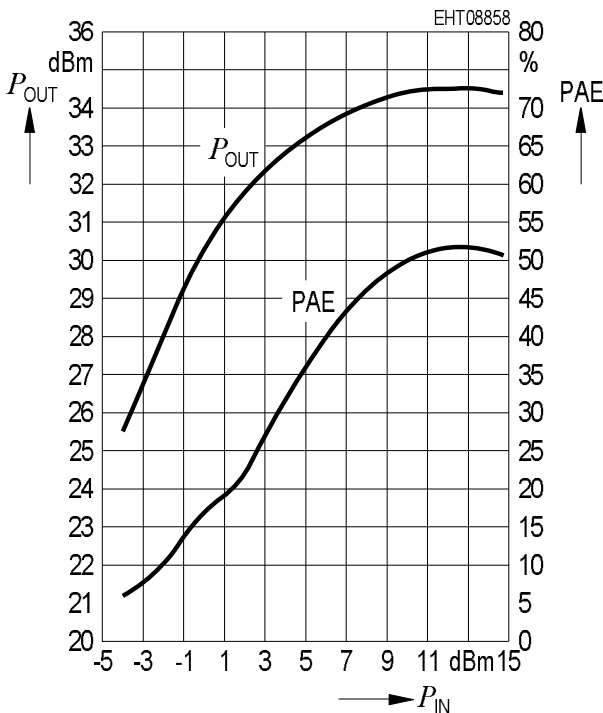

CGY 93 – P_{out} vs. Drain Voltage

@ 900 MHz, $P_{in} = 12$ dBm

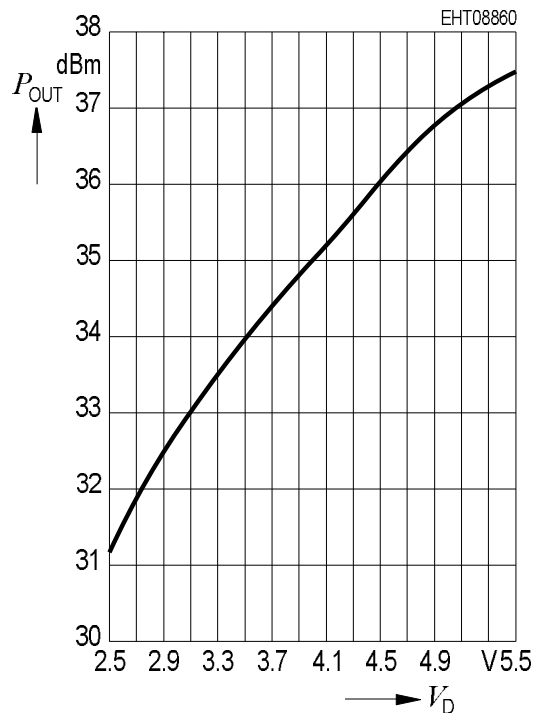

GSM Application Board CGY 93

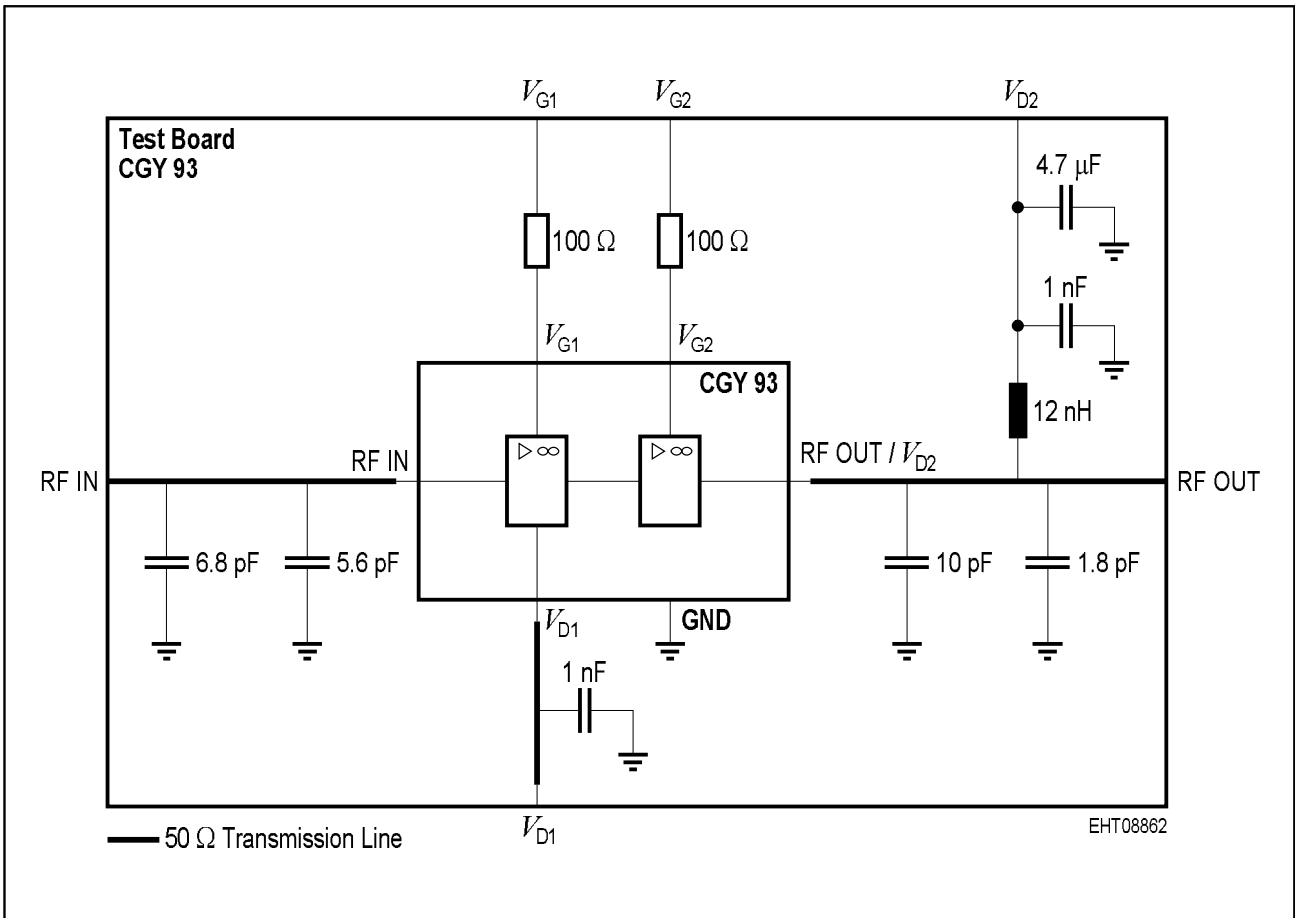

Figure 2

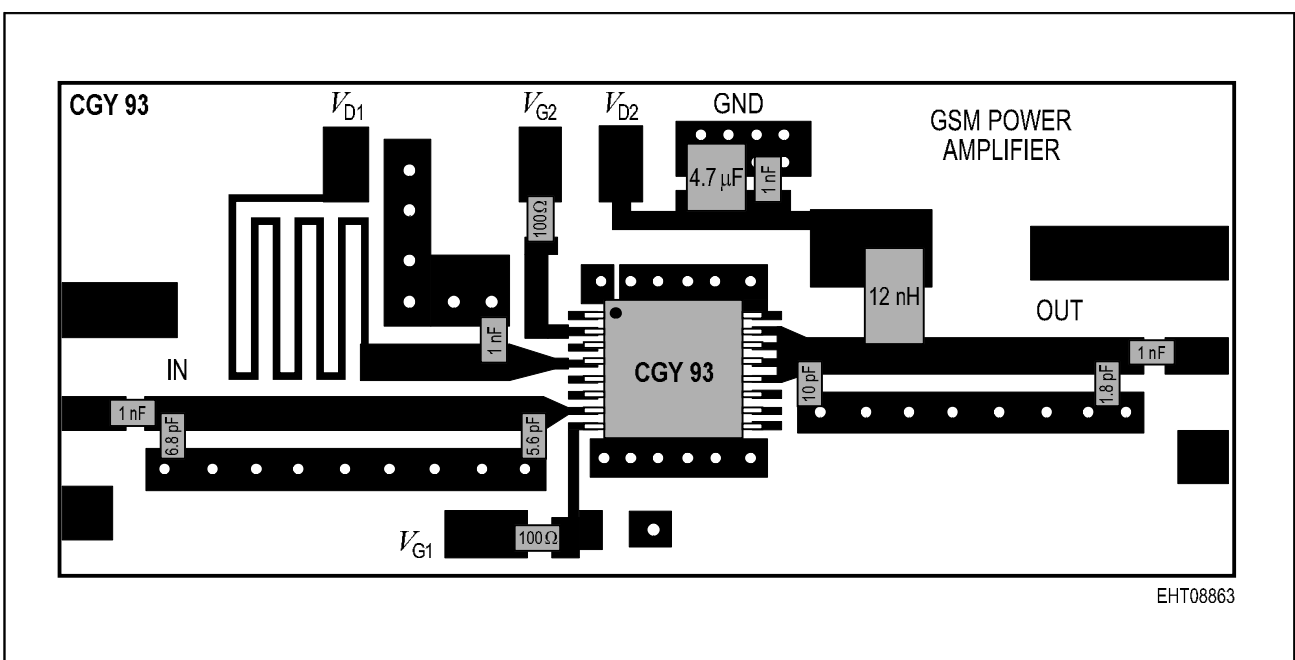

Figure 3

Determination of Permissible Total Power Dissipation for Continuous and Pulse Operation

The purpose of the following procedure is to prevent the junction temperature T_J from exceeding the maximum allowed data sheet value. T_J is determined by the dissipated power and the thermal properties of the device and board. The dissipated power is the power which remains in the chip and heats the device and junction. It does not contain RF signals which are coupled out consistently.

This is a two step approach: For a pulsed condition both steps are needed. For CW and DC step one is sufficient.

Step 1: Continuous Wave DC Operation

For the determination of the permissible total power dissipation $P_{\text{tot-DC}}$ from the diagram below it is necessary to obtain the temperature of the case T_C first. Because the MW-16 heat sink is not easily accessible to a temperature measurement the thermal resistance is defined as R_{thJC} using the case temperature T_C . There are two cases:

- When R_{thCA} (case to ambient) is not known: Measure T_C in operation of device and board at the upper side of the case where the temperature is highest. Small thermoelements ($< 1 \text{ mm}$, thin wires, thermopaste) or thermopapers with low heat dissipation are well suited.

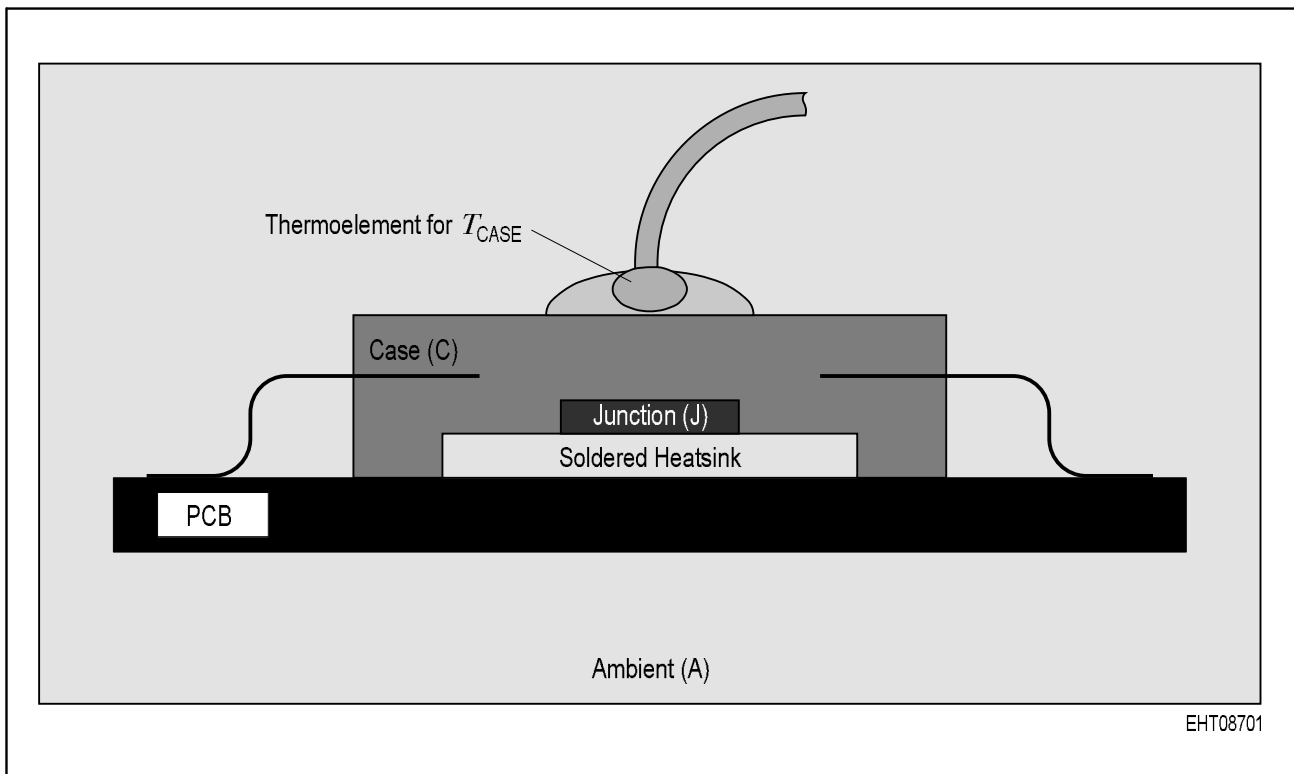
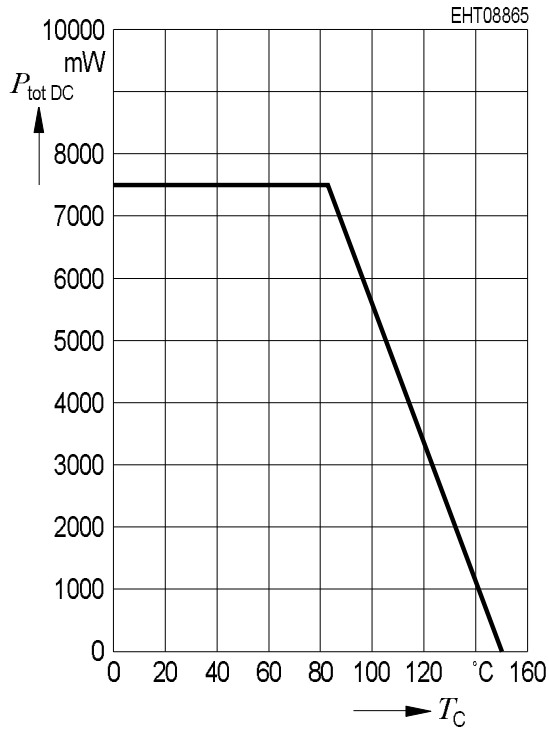

Figure 4 Measurement of Case Temperature T_C

- When R_{thCA} is already known.

Calculate the case temperature as $T_C = P_{diss} \times R_{thCA} + T_A$ Graph for P_{tot-DC}

P_{tot-DC} in mW



Step 2: Pulsed Operation

For the calculation of the permissible pulse load $P_{tot-max}$ the following formula is applicable:

$$P_{tot-max} = P_{tot-DC} \times \text{Pulse Factor} = P_{tot-DC} \times (P_{tot-max}/P_{tot-DC})$$

Use the values for P_{tot-DC} as derived from the above diagram and for the Pulse Factor = $P_{tot-max}/P_{tot-DC}$ from the following diagram to get a specific value.

Pulse Factor

$$P_{\text{tot-max}}/P_{\text{tot-DC}} = f(t_p)$$

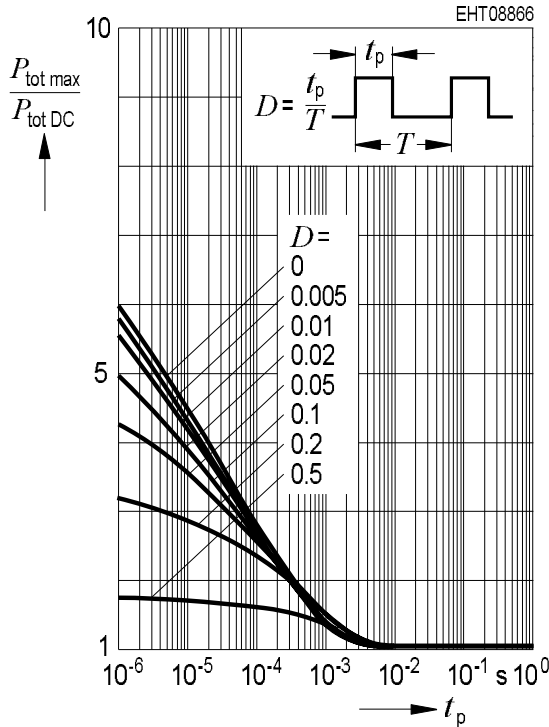

$P_{\text{tot-max}}$ should not exceed the absolute maximum rating for the dissipated power

$$P_{\text{Pulse}} = \text{“Pulse peak power”} = 17 \text{ W}$$

Reliability Considerations

The above procedure yields the upper limit for the power dissipation for continuous wave (cw) and pulse applications which correspond to the maximum allowed junction temperature. For best reliability keep the junction temperature low. The following formula allows to track the individual contributions which determine the junction temperature.

$T_J =$	$(P_{\text{tot-diss}}/ \text{Pulse Factor} \times$	$R_{\text{thJC}}) +$	T_C
Junction temperature (= channel temperature)	Power dissipated in the chip, divided by the applicable pulse factor (= 1 for DC and CW). It does not contain decoupled RF- power	R_{th} of device from junction to case	Temperature of the case, measured or calculated, device and board operating

Package Outlines

MW-16
(Special Package)

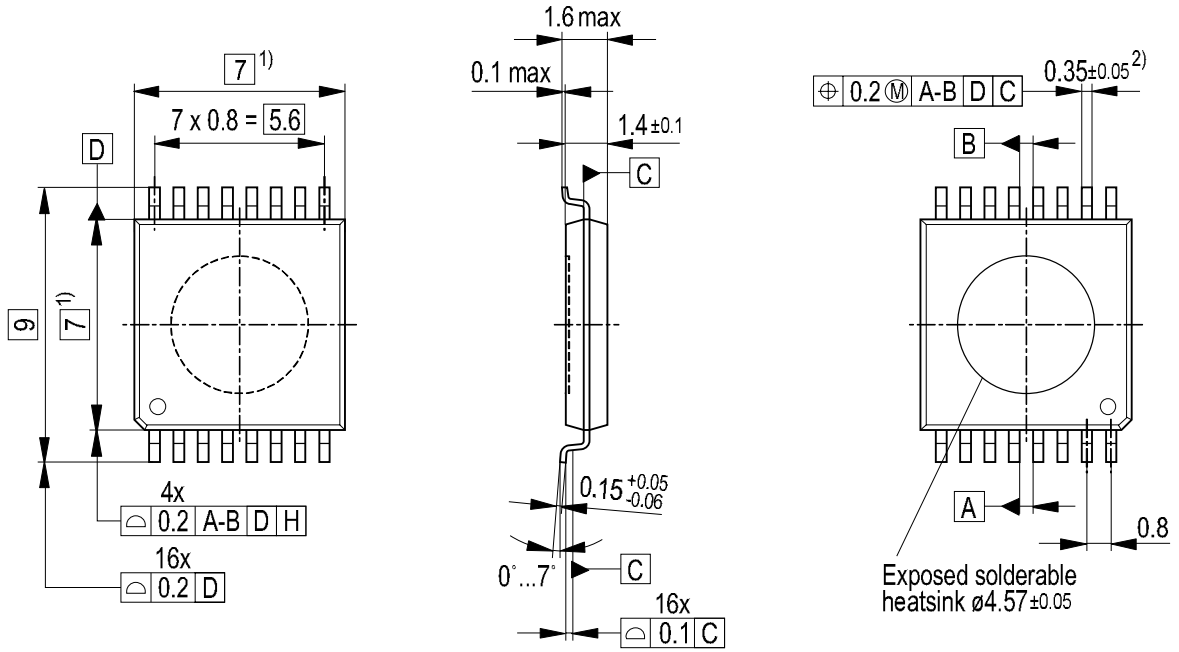

GPW05969

Sorts of Packing

Package outlines for tubes, trays etc. are contained in our Data Book "Package Information".

SMD = Surface Mounted Device

Dimensions in mm