

1. General Description

This EPROM-Based 8-bit micro-controller uses a fully static CMOS technology process to achieve higher speed and smaller size with the low power consumption and high noise immunity. On chip memory includes 2K words of ROM, and 128 bytes of static RAM.

2. Features

The followings are some of the features on the hardware and software :

- ◆ Fully CMOS static design
- ◆ 8-bit data bus
- ◆ On chip EPROM size : 2.0 K words
- ◆ Internal RAM size : 161 bytes
(128 general purpose registers, 33 special registers)
- ◆ 37 single word instructions
- ◆ 14-bit instructions
- ◆ 8-level stacks
- ◆ Operating voltage : 2.5 V ~ 5.5 V (PRD Disable)
4.5 V ~ 5.5 V (PRD Enable)
- ◆ Operating frequency : DC ~ 20 MHz
- ◆ The most fast execution time is 200 ns under 20 MHz in all single cycle instructions except the branch instruction
- ◆ Addressing modes include direct, indirect and relative addressing modes
- ◆ Power-on Reset
- ◆ Power edge-detector Reset
- ◆ Power range-detector Reset
- ◆ Sleep Mode for power saving
- ◆ 8 interrupt sources:
 - External INT pin
 - TMR0 timer,TMR1 timer,TMR2 timer
 - PortB<7:4> interrupt on change
 - CCP,SCM,PCM
- ◆ Capture,Compare,PWM module
- ◆ Synchronous serial port with SCM
- ◆ Parallel communication mode(PCM)
- ◆ TMR0 : 8-bit real time clock/counter
- ◆ TMR1 : 16-bit real time clock/count
- ◆ TMR2 : 8-bit clock/counter(internal)
- ◆ 4 types of oscillator can be selected by programming option:
 - RC - Low cost RC oscillator
 - LFXT - Low frequency crystal oscillator
 - XTAL - Standard crystal oscillator
 - HFXT - High frequency crystal oscillator
- ◆ On-chip RC oscillator based Watchdog Timer(WDT)
- ◆ 33 I/O pins with their own independent direction control

3. Applications

The application areas of this MDT10P64 range from appliance motor control and high speed auto-motive to low power remote transmitters/receivers, pointing devices, and telecommunications processors, such as Remote controller, small instruments, toy, automobile and PC peripheral ... etc.

4. Pin Assignment

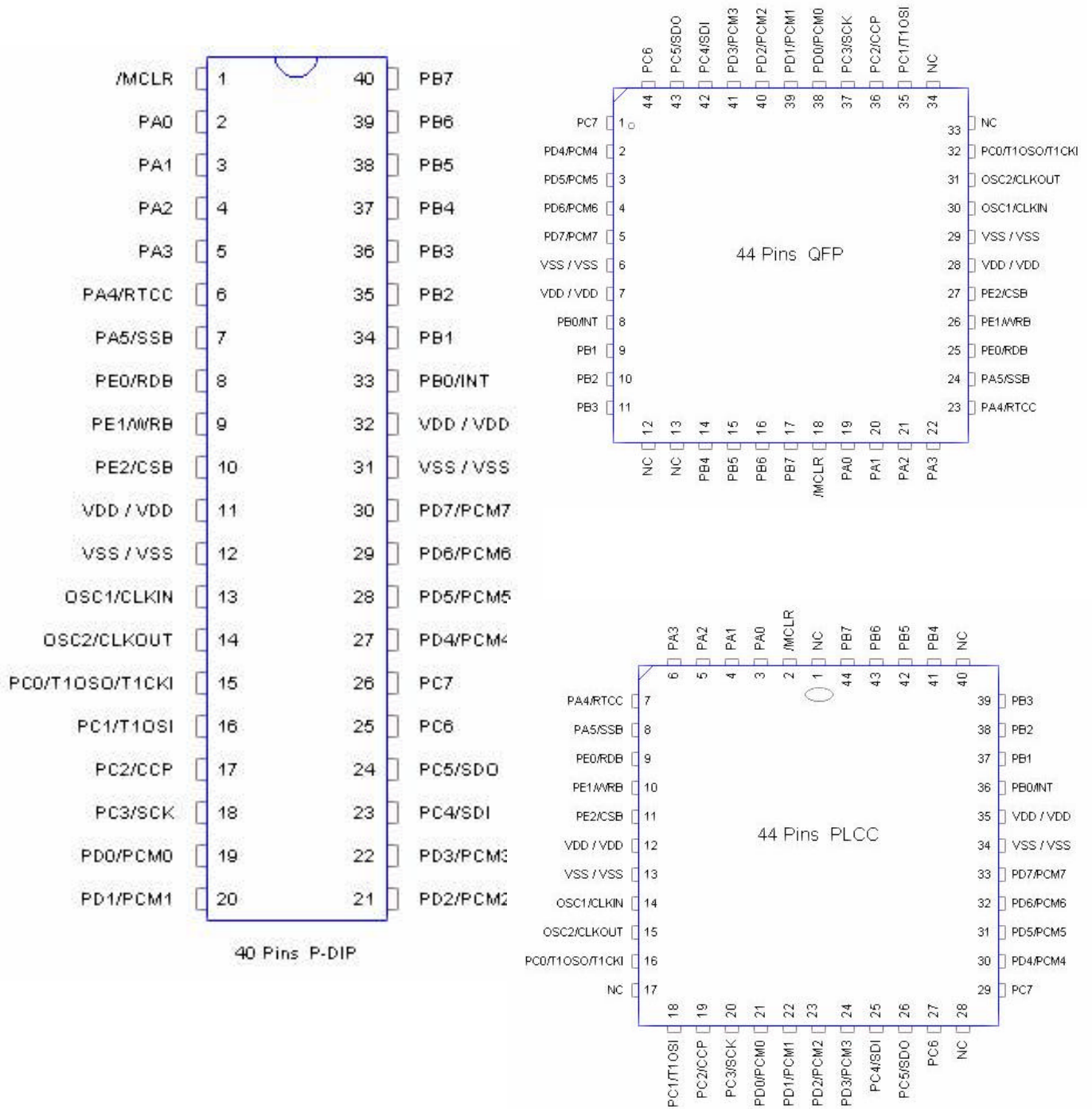

5. Pin Function Description

Pin Name	I/O	Function Description
PA0~PA3,PA5	I/O	Port A, TTL input level
RTCC/PA4	I/O	Real Time Clock/Counter, Schmitt Trigger input levels Open drain output
PB0~PB7	I/O	Port B, TTL input level / PB0:External interrupt input , PB4~PB7:Interrupt on pin change
PC0~PC7	I/O	Port C, Schmitt Trigger input levels
PD0~PD7	I/O	Port D, Schmitt Trigger input levels / TTL input level
PE0~PE2	I/O	Port E, Schmitt Trigger input levels / TTL input level
/MCLR	I	Master Clear, Schmitt Trigger input levels
OSC1/CLKIN	I	Oscillator Input/external clock input
OSC2/CLKOUT	O	Oscillator Output/in RC mode , the CLKOUT pin has 1/4 frequency of CLKIN
V _{dd}		Power supply
V _{ss}		Ground

6. Memory Map

(A) Register Map

Address	Description
BANK0	
00	Indirect Addressing Register
01	RTCC
02	PCL
03	STATUS
04	MSR
05	Port A
06	Port B
07	Port C
08	Port D
09	Port E
0A	PCHLAT

Address	Description
0B	INTS
0C	PIFB1
0E	TMR1L
0F	TMR1H
10	T1STA
11	TMR2
12	T2STA
13	SCMBUF
14	SCMCTL
15	CCPL
16	CCPH
17	CCPCTL
20~7F	General purpose register
BANK1	
01	TMR
05	CPIO A
06	CPIO B
07	CPIO C
08	CPIO D
09	CPIO E
0C	PIEB1
0E	PSTA
12	T2PER
14	SCMSTA
A0~BF	General purpose register

(1) IAR (Indirect Address Register) : R00

(2) RTCC (Real Time Counter/Counter Register) : R01

(3) PC (Program Counter) : R02,R0A

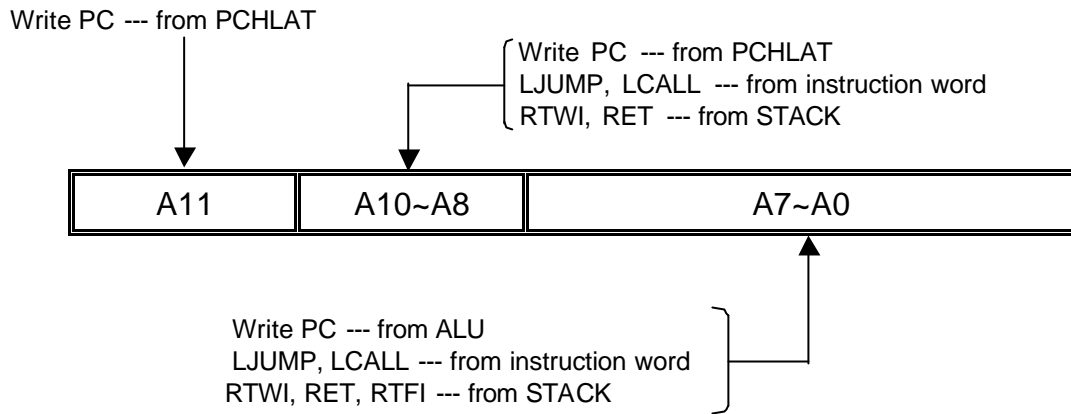

(4) STATUS (Status register) : R03

Bit	Symbol	Function
0	C	Carry bit
1	HC	Half Carry bit
2	Z	Zero bit
3	/PF	Power down Flag bit
4	/TF	WDT Timer overflow Flag bit
5	RBS0	Register Bank Select bit : 0 : 00H --- 7FH (Bank0) 1 : 80H --- FFH (Bank1)
6-7	---	General purpose bit

(5) MSR (Memory Bank Select Register) : R04

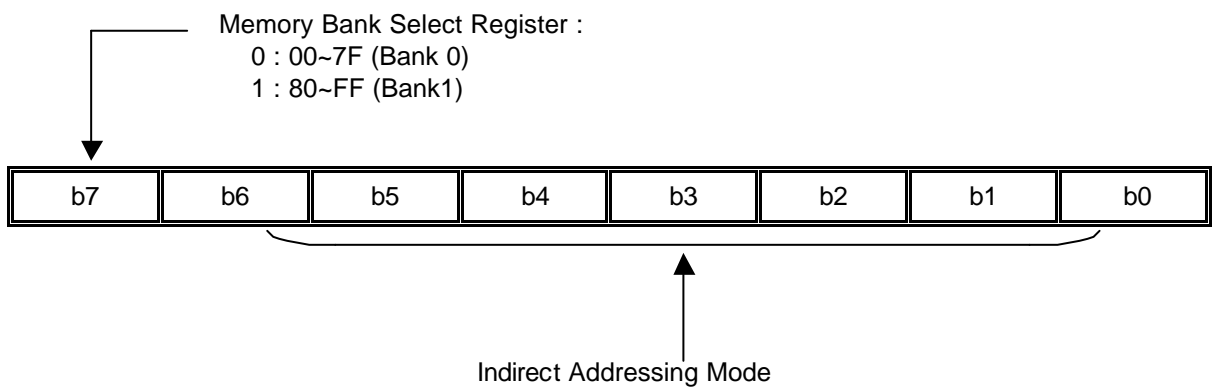

(6) PORT A : R05

PA5~PA0, I/O Register

(7) PORT B : R06

PB7~PB0, I/O Register

(8) PORT C : R07
PC7~PC0, I/O Register

(9) PORT D : R08
PD7~PD0, I/O Register

(10) PORT E : R09
PE2~PE0, I/O Register

(11) PCHLAT : R0A

(12) INTS (Interrupt Status Register) : R0B

Bit	Symbol	Function
0	RBIF	PORT B change interrupt flag. Set when PB <7:4> inputs change
1	INTF	Set when INT interrupt occurs. INT interrupt flag.
2	TIF	Set when TMR0 overflows.
3	RBIE	0 : disable PB change interrupt 1 : enable PB change interrupt
4	INTS	0 : disable INT interrupt 1 : enable INT interrupt
5	TIS	0 : disable TMR0 interrupt 1 : enable TMR0 interrupt
6	PEIE	0 : disable all peripheral interrupt 1 : enable all peripheral interrupt
7	GIS	0 : disable global interrupt 1 : enable global interrupt

(13) PIFB1 (Peripheral Interrupt Flag Bit) : R0C

Bit	Symbol	Function
0	TMR1IF	TMR1 interrupt flag 0 : TMR1 did not overflow 1 : TMR1 overflowed
1	TMR2IF	TMR2 interrupt flag 0 : No TMR2 to T2PER match occurred 1 : TMR2 to T2PER match occurred
2	CCPIF	CCP interrupt flag 0 : No TMR1 capture/compare occurred 1 : A TMR1 capture/compare occurred

Bit	Symbol	Function
3	SCMIF	SCM interrupt flag 0 : No read or write has occurred 1 : A read or a write has occurred
6~4	--	Unimplemented
7	PCMIF	PCM interrupt flag 0 : No R/W operation has taken place 1 : A R/W operation has taken place

(14) TMR1L : R0E

The LSB of the 16-bit TMR1

(15) TMR1H : R0F

The MSB of the 16-bit TMR1

(16) T1STA : R10

Bit	Symbol	Function
0	TMR1ON	0 : Stop TMR1 1 : Enable TMR1
1	TMR1CLK	0 : Internal clock (Fosc/4) 1 : External clock from pin PC0
2	/T1SYNC	TMR1CLK = 1 0 : Synchronize external clock 1 : Do not synchronize external clock TMR1CLK = 0 This bit is ignored
3	T1OSCEN	0 : TMR1 Oscillator is shut off 1 : TMR1 Oscillator is enable
5~4	T1CKPS1 ~ T1CKPS0	1 1 = 1:8 Prescale value 1 0 = 1:4 Prescale value 0 1 = 1:2 Prescale value 0 0 = 1:1 Prescale value
7~6	--	Unimplemented

(17) TMR2 : R11

TMR2 register

(18) T2STA : R12

Bit	Symbol	Function
1~0	T2CKPS1 ~ T2CKPS0	0 0 = Prescaler is 1 0 1 = Prescaler is 4 1 x = Prescaler is 16
2	TMR2ON	0 : TMR2 is off 1 : TMR2 is on
7~3	--	Unimplemented

(19) SCMBUF : R13

Serial communication port buffer

(20) SCMCTL : R14

Bit	Symbol	Function
3~0	SCM3 ~ SCM0	0 0 0 0 : SCM master mode , clock = Fosc/4 0 0 0 1 : SCM master mode , clock = Fosc/16 0 0 1 0 : SCM master mode , clock = Fosc/64 0 0 1 1 : SCM master mode , clock = TMR2 output/2 0 1 0 0 : SCM slave mode , clock = SCK pin , /SS control enable 0 1 0 1 : SCM slave mode , clock = SCK pin , /SS control disable
4	CKS	0 : Transmit happens on rising edge , receive on falling edge, Idle state for clock is low level. 1 : Transmit happens on falling edge , receive on rising edge, Idle state for clock is high level
5	SCMEN	0 : Disable SCM, then pc3, pc4, pc5 is I/O prot 1 : Enable SCM
6	SCMROI	0 : No overflow 1 : Overflow
7	WCOL	0 : No collision 1 : The SCMBUF is written while it is still transmitting the previous word

(21) CCPL : R15

Capture/Compare/PWM LSB

(22) CCPH : R16

Capture/Compare/PWM MSB

(23) CCPCTL : R17

Bit	Symbol	Function
3~0	CCPM3 ~ CCPM0	0 0 0 0 : CCP off 0 1 0 0 : Capture mode , every falling edge 0 1 0 1 : Capture mode , every rising edge 0 1 1 0 : Capture mode , every 4 th rising edge 0 1 1 1 : Capture mode , every 16 th rising edge 1 0 0 0 : Compare mode , set output on match 1 0 0 1 : Compare mode , clear output on match 1 0 1 0 : Compare mode , generate software interrupt on match 1 0 1 1 : Compare mode , trigger special event 1 1 x x : PWM mode
5~4	PWMLSB	These bits are the two LSBs of the PWM duty cycle
7~6	--	Unimplemented

(24) TMR (Time Mode Register) : R81

Bit	Symbol	Function		
2~0	PS2~0	Prescaler Value	RTCC rate	WDT rate
		0 0 0	1 : 2	1 : 1
		0 0 1	1 : 4	1 : 2
		0 1 0	1 : 8	1 : 4
		0 1 1	1 : 16	1 : 8
		1 0 0	1 : 32	1 : 16
		1 0 1	1 : 64	1 : 32
		1 1 0	1 : 128	1 : 64
1 1 1	1 : 256	1 : 128		
3	PSC	Prescaler assignment bit : 0 : RTCC 1 : Watchdog Timer		
4	TCE	RTCC signal Edge : 0 : Increment on low-to-high transition on RTCC pin 1 : Increment on high-to-low transition on RTCC pin		
5	TCS	RTCC signal set : 0 : Internal instruction cycle clock 1 : Transition on RTCC pin		
6	IES	Interrupt edge select 0 : Interrupt on falling edge on PB0 1 : Interrupt on rising edge on PB0		
7	PBPH	PORTB3~0 pull-hi 0 : PORTB3~0 pull-hi are enable 1 : PORTB3~0 pull-hi are disable		

(25) CPIO A (Control Port I/O Mode Register) : R85

= "0", I/O pin in output mode.

= "1", I/O pin in input mode.

- (26) CPIO B (Control Port I/O Mode Register) : R86
 = "0", I/O pin in output mode.
 = "1", I/O pin in input mode.
- (27) CPIO C (Control Port I/O Mode Register) : R87
 = "0", I/O pin in output mode.
 = "1", I/O pin in input mode.
- (28) CPIO D (Control Port I/O Mode Register) : R88
 = "0", I/O pin in output mode.
 = "1", I/O pin in input mode.
- (29) CPIO E (Control Port I/O Mode Register) : R89

Bit	Symbol	Function
2~0	BIT2~BIT0	Port E control port I/O mode bits 0 : I/O pin in output mode 1 : I/O pin in input mode
3	--	Unimplemented
4	PCMSB	0 : General I/O mode 1 : PCM mode
5	IBOB	0 : No overflow occurred 1 : A write occurred when a previously input word has not been read
6	OBF	0 : The output buffer has been read 1 : The output buffer still holds
7	IBF	0 : No data has been received 1 : A data has been received and is waiting to be read

- (30) PIEB1 : R8C

Bit	Symbol	Function
0	TMR1IE	TMR1 interrupt enable bit 0 : Disable TMR1 interrupt 1 : Enable TMR1 interrupt
1	TMR2IE	TMR2 interrupt enable bit 0 : Disable TMR2 interrupt 1 : Enable TMR2 interrupt
2	CCP1IE	CCP1 interrupt enable bit 0 : disable CCP1 interrupt 1 : enable CCP1 interrupt
3	SCMIE	SCM interrupt enable bit 0 : Disable SCM interrupt 1 : Enable SCM interrupt

Bit	Symbol	Function
6~4	--	Unimplemented
7	PCMIE	PCM interrupt enable bit 0 : Disable PCM interrupt 1 : Enable PCM interrupt

(31) PSTA : R8E

Bit	Symbol	Function
0	PRDB	0 : Power range-detector Reset occurred 1 : No Power range-detector Reset Occurred
1	PORB	0 : Power on Reset occurred 1 : No Power on Reset occurred

(32) T2PER : R92
Timer2 period

(33) SCMSTA : R94

Bit	Symbol	Function
0	BF	0 : Receive not complete 1 : Receive complete
7~1	--	Unimplemented

(34) Configurable options for EPROM (Set by writer) :

Oscillator Type
RC Oscillator
HFXT Oscillator
XTAL Oscillator
LFXT Oscillator

Watchdog Timer control
Watchdog timer disable all the time
Watchdog timer enable all the time

Power-range control
Power-range disable
Power-range enable

Oscillator-start Timer control
0ms
75ms

Power-edge Detect
PED Disable
PED Enable

Security state
Security Disable
Security Enable

(B) Program Memory

Address	Description
000-7FF	Program memory
000	The starting address of power on, external reset or WDT time-out reset.
004	Interrupt vector

7. Reset Condition for all Registers

Register	Address	Power-On Reset, Power range detector Reset	/MCLR or WDT Reset	Wake-up from SLEEP
IAR	00h	N/A	N/A	N/A
RTCC	01h	xxxx xxxx	uuuu uuuu	uuuu uuuu
PC	0Ah,02h	0000 0000 0000	0000 0000 0000	PC+1
STATUS	03h	0001 1xxx	000# #uuu	000# #uuu
MSR	04h	xxxx xxxx	uuuu uuuu	uuuu uuuu
PORT A	05h	--xx xxxx	--uu uuuu	--uu uuuu
PORT B	06h	xxxx xxxx	uuuu uuuu	uuuu uuuu
PORT C	07h	xxxx xxxx	uuuu uuuu	uuuu uuuu
PORT D	08h	xxxx xxxx	uuuu uuuu	uuuu uuuu
PORT E	09h	---- -xxx	---- -uuu	---- -uuu
PCHLAT	0Ah	---0 0000	---0 0000	---u uuuu
INTS	0Bh	0000 000x	0000 000u	uuuu uuuu
PIFB1	0Ch	---- 0000	---- 0000	---- uuuu
TMR1H	0Fh	xxxx xxxx	uuuu uuuu	uuuu uuuu
T1STA	10h	--00 0000	--uu uuuu	--uu uuuu

Register	Address	Power-On Reset, Power range detector Reset	/MCLR or WDT Reset	Wake-up from SLEEP
TMR1L	0Eh	xxxx xxxx	uuuu uuuu	uuuu uuuu
TMR2	11h	0000 0000	0000 0000	uuuu uuuu
T2STA	12h	---- -000	---- -uuu	---- -uuu
SCMBUF	13h	xxxx xxxx	uuuu uuuu	uuuu uuuu
SCMCTL	14h	0000 0000	0000 0000	uuuu uuuu
CCPL	15h	xxxx xxxx	uuuu uuuu	uuuu uuuu
CCPH	16h	xxxx xxxx	uuuu uuuu	uuuu uuuu
CCPCTL	17h	--00 0000	--00 0000	--uu uuuu
TMR	81h	1111 1111	1111 1111	uuuu uuuu
CPIOA	85h	--11 1111	--11 1111	--uu uuuu
CPIOB	86h	1111 1111	1111 1111	uuuu uuuu
CPIOC	87h	1111 1111	1111 1111	uuuu uuuu
CPIOD	88h	1111 1111	1111 1111	uuuu uuuu
CPIOE	89h	0000 -111	0000 -111	uuuu -uuu
PIEB1	8Ch	0--- 0000	0--- 0000	u--- uuuu
PSTA	8Eh	---- --0u	---- --uu	---- --uu
T2PER	92h	1111 1111	1111 1111	1111 1111
SCMSTA	94h	---- --0	---- --0	---- --u

Note : u = unchanged, x = unknown, - = unimplemented, read as "0"

= value depends on the condition of the following table

Condition	Status: bit 4	Status: bit 3	PSTA: bit 1	PSTA: bit 0
/MCLR reset (not during SLEEP)	u	u	u	u
/MCLR reset during SLEEP	1	0	u	u
WDT reset (not during SLEEP)	0	1	u	u
WDT reset during SLEEP	0	0	u	u
Power-on reset	1	1	0	x
Power-range reset	1	1	u	0

Note : u = unchanged, x = unknown, - = unimplemented, read as "0"

8. Instruction Set :

Instruction Code	Mnemonic Operands	Function	Operating	Status
010000 00000000	NOP	No operation	None	
010000 00000001	CLRWT	Clear Watchdog timer	0 WT	TF, PF
010000 00000010	SLEEP	Sleep mode	0 WT, stop OSC	TF, PF
010000 00000011	TMODE	Load W to TMODE register	W TMODE	None
010000 00000100	RET	Return from subroutine	Stack PC	None
010000 00000rrr	CPIO R	Control I/O port register	W CPIO r	None
010001 1rrrrrrr	STWR R	Store W to register	W R	None
011000 trrrrrrr	LDR R, t	Load register	R t	Z
111010 iiiiii	LDWI I	Load immediate to W	I W	None
010111 trrrrrrr	SWAPR R, t	Swap halves register	[R(0~3) ↔ R(4~7)] t	None
011001 trrrrrrr	INCR R, t	Increment register	R + 1 t	Z
011010 trrrrrrr	INCRSZ R, t	Increment register, skip if zero	R + 1 t	None
011011 trrrrrrr	ADDWR R, t	Add W and register	W + R t	C, HC, Z
011100 trrrrrrr	SUBWR R, t	Subtract W from register	R - W t or (R+/W+1 t)	C, HC, Z
011101 trrrrrrr	DECR R, t	Decrement register	R - 1 t	Z
011110 trrrrrrr	DECRSZ R, t	Decrement register, skip if zero	R - 1 t	None
010010 trrrrrrr	ANDWR R, t	AND W and register	R W t	Z
110100 iiiiii	ANDWI i	AND W and immediate	i W W	Z
010011 trrrrrrr	IORWR R, t	Inclu. OR W and register	R W t	Z
110101 iiiiii	IORWI i	Inclu. OR W and immediate	i W W	Z
010100 trrrrrrr	XORWR R, t	Exclu. OR W and register	R W t	Z
110110 iiiiii	XORWI i	Exclu. OR W and immediate	i W W	Z
011111 trrrrrrr	COMR R, t	Complement register	/R t	Z
010110 trrrrrrr	RRR R, t	Rotate right register	R(n) R(n-1), C R(7), R(0) C	C
010101 trrrrrrr	RLR R, t	Rotate left register	R(n) r(n+1), C R(0), R(7) C	C
010000 1xxxxxxx	CLRW	Clear working register	0 W	Z
010001 0rrrrrrr	CLRR R	Clear register	0 R	Z
0000bb brrrrrrr	BCR R, b	Bit clear	0 R(b)	None
0010bb brrrrrrr	BSR R, b	Bit set	1 R(b)	None
0001bb brrrrrrr	BTSC R, b	Bit Test, skip if clear	Skip if R(b)=0	None
0011bb brrrrrrr	BTSS R, b	Bit Test, skip if set	Skip if R(b)=1	None

This specification are subject to be changed without notice. Any latest information please preview

Instruction Code	Mnemonic Operands	Function	Operating	Status
100nnn nnnnnnnn	LCALL n	Long CALL subroutine	n PC, PC+1 Stack	None
101nnn nnnnnnnn	LJUMP n	Long JUMP to address	n PC	None
110111 iiiiii	ADDWI i	Add immediate to W	W+i W	C,HC,Z
110001 iiiiii	RTWI i	Return, place immediate to W	Stack PC,i W	None
111000 iiiiii	SUBWI i	Subtract W from immediate	i-W W	C,HC,Z
010000 00001001	RTFI	Return from interrupt	Stack PC,1 GIS	None

Note :

W	:	Working register	b	:	Bit position
WT	:	Watchdog timer	t	:	Target
TMODE	:	TMODE mode register	0	:	Working register
CPIO	:	Control I/O port register	1	:	General register
TF	:	Timer overflow flag	R	:	General register address
PF	:	Power loss flag	C	:	Carry flag
PC	:	Program Counter	HC	:	Half carry
OSC	:	Oscillator	Z	:	Zero flag
Inclu.	:	Inclusive ' '	/	:	Complement
Exclu.	:	Exclusive ' '	x	:	Don' t care
AND	:	Logic AND ' '	I	:	Immediate data (8 bits)

9. Electrical Characteristics

*Note: Temperature=25°C

1.Operation Current :

(1) HF (C=10p) , WDT - disable, PRD – disable

	4M	10M	20M	Sleep
2.5V	330u	710u	1.3m	<1u
3.0V	480u	910u	1.7m	<1u
4.0V	720u	1.4m	2.8m	<1u
5.0V	1.4m	2.6m	4.3m	<1u
5.5V	1.8m	3.5m	5.7m	<1u

These parameters are for reference only.

(2) XT (C=10p) , WDT - disable, PRD – disable

	1M	4M	10M	Sleep
2.5V	100u	310u	600u	<1u
3.0V	220u	450u	860u	<1u
4.0V	310u	660u	1.3m	<1u
5.0V	560u	1.0m	1.9m	<1u
5.5V	780u	1.5m	2.9m	<1u

These parameters are for reference only.

This specification are subject to be changed without notice. Any latest information please preview

(3) LF (C=10p) , WDT - disable, PRD - disable,

	32K	455K	1M	Sleep
2.5V	10u	@2.7V 50u	80u	<1u
3.0V	15u	60u	90u	<1u
4.0V	25u	80u	150u	<1u
5.0V	40u	140u	230u	<1u
5.5V	80u	250u	390u	<1u

These parameters are for reference only.

(4) RC, WDT - disable; PRD - disable; @Vdd = 5.0V

C	R	Freq.	Current
3p	4.7k	8.4M	1.7m
	10k	4.5M	1.1m
	47k	1.1M	430u
	100k	520K	330u
	300k	180K	165u
	470k	110K	155u
20p	4.7k	3.2M	1.3m
	10k	2.2M	640u
	47k	500K	230u
	100k	240K	180u
	300k	81.2K	150u
	470k	51.6K	145u
100p	4.7k	1.4M	500u
	10k	688K	370u
	47k	152K	165u
	100k	72.8K	150u
	300k	24.4K	140u
	470k	15.6K	138u
300p	4.7k	592K	350u
	10k	292K	190u
	47k	64K	147u
	100k	30.8K	141u
	300k	10.4K	137u
	470k	6.4K	136u

These parameters are for reference only.

2. Input Voltage (Vdd = 5V) :

	Port	Min	Max
Vil	TTL	Vss	0.8V
	Schmitt trigger	Vss	0.6V
Vih	TTL	3.0V	Vdd
	Schmitt trigger	3.8V	Vdd

These parameters are for reference only.

Input Voltage (Vdd = 3V) :

	Port	Min	Max
Vil	TTL	Vss	0.4V
	Schmitt trigger	Vss	0.2V
Vih	TTL	2.0V	Vdd
	Schmitt trigger	2.6V	Vdd

These parameters are for reference only.

3. Output Voltage (Vdd = 5V) :

	PA,PB	Condition
Voh	3.5V	Ioh = -20mA
Vol	0.9V	Iol = 20mA
Voh	4.2V	Ioh = -5mA
Vol	0.7V	Iol = 5mA

These parameters are for reference only.

4. Output Current (Max.) (Vdd = 5V) :

I/O Port		Current
	source current	25mA
	sink current	40mA

These parameters are for reference only.

5. The basic WDT time-out cycle time :

	Time
2.5V	26
3.0V	23
4.0V	20
5.0V	18
5.5V	17

Unit = ms

These parameters are for reference only.

6.PRD :

(1)PRD reset voltage :

	Voltage
Vih	4.0±10%
Vil	3.6±10%

Unit = V

These parameters are for reference only.

(2) PRD reset current :

	Current
5.0V	120
4.0V	100

Unit = uA

These parameters are for reference only.

7.Pull high resistor :

Vdd	5V	3V
PB3~0 Pull high	40	80

Unit = K Ohm

These parameters are for reference only.

8.MCLR filter time :

Vdd=5V	
time	640

Unit = ns

These parameters are for reference only.