



# MAX1639 Evaluation Kit

Evaluates: MAX1639

## General Description

The MAX1639 evaluation kit (EV kit) provides a 2.5V output voltage from a +4.5V to +5.5V input supply. It delivers up to 8A output current with greater than 90% efficiency. Features include pin-selectable switching frequencies of 300kHz, 600kHz, and 1MHz, as well as current-mode operation for superior load- and line-transient response. This EV kit operates at 600kHz switching frequency. It can also be used to evaluate other output voltages by changing the feedback resistors R2 and R3.

This EV kit is fully assembled and tested, and is offered in a 16-pin narrow SO package.

## Component List

DESIGNATION	QTY	DESCRIPTION
C1	1	330µF, 6.3V, low-ESR capacitor Sanyo 6SA330M
C2, C3	2	560µF, 4V, low-ESR capacitors Sanyo 4SP560M
C4, C5, C9	3	0.1µF ceramic capacitors
CC1	1	1000pF ceramic capacitor
CC2	1	0.056µF ceramic capacitor
C6	1	2.2µF, 10V ceramic capacitor TDK C3216X7R1C225M or Taiyo Yuden EMK316BJ225ML
C7	1	10µF, 10V tantalum capacitor Sprague 595D106X0010A2T
C8	1	4.7µF, 16V tantalum capacitor Sprague 595D475X0016A2T
C10, D1	0	Not installed
D2	1	Schottky diode Central Semiconductor CMPSH-3
L1	1	1.0µH power inductor Coiltronics UP2B-1R0 or Coilcraft DO3316P-102HC
N1, N2	1	N-channel MOSFETs (SO-8) Fairchild FDS6680
R1	1	0.009Ω, 1%, 1W resistor Dale WSL-2512-R009-F or IRC LR2512-01-R009-F
R2	1	12.7kΩ, 1% resistor
R3	1	10kΩ, 1% resistor
R4	1	10Ω, 5% resistor
R5	1	100kΩ, 5% resistor
R6	1	1kΩ, 5% resistor
U1	1	MAX1639ESE
JU1	1	2-pin header
None	1	Shunt
None	1	MAX1639 PC board
None	1	MAX1639 data sheet

## Features

- ◆ +4.5V to +5.5V Input Voltage Range
- ◆ 2.5V Output Voltage (1.1V to 4.0V adjustable)
- ◆ 8A Output Current
- ◆ Power-Good Output
- ◆ 600kHz Switching Frequency
- ◆ 16-Pin Narrow SO Package
- ◆ Fully Assembled and Tested

## Ordering Information

PART	TEMP. RANGE	PIN-PACKAGE
MAX1639EVKIT	0°C to +70°C	16 Narrow SO

## Quick Start

The MAX1639 EV kit is fully assembled and tested. Follow these steps to verify board operation. **Do not turn on the power supply until all connections are completed.**

- 1) Connect a +5V supply voltage to the VIN pad. Connect ground to the GND pad.
- 2) Connect a voltmeter and load, if any, to the VOUT pad.
- 3) Remove the shunt from JU1.
- 4) Turn on the power supply to the board. Verify that the output voltage is 2.5V.

## Detailed Description

The MAX1639 provides a 2.5V output from 4.5V to 5.5V input voltage. It delivers up to 8A and operates at 600kHz. Other output voltages can be programmed by changing the feedback resistor R2. R2 is given by:

$$R2 = R3 \left( \frac{V_{OUT}}{1.1} - 1 \right)$$

where R3 = 10kΩ.

For output voltages greater than 3.3V, use appropriately rated output capacitors (C2, C3).

## Jumper Selection

The 2-pin header JU1 selects the shutdown mode. Table 1 lists the selectable jumper options.

The 4-pin header JU2 selects the switching frequency. Table 2 lists the selectable jumper options. The EV kit's components are selected for 600kHz operation. If 300kHz or 1MHz operation is selected, component values need to be changed and the PC board trace between pins 1 and 2 of JU2 must be cut (refer to the *Design Procedure* section in the MAX1639 data sheet).



# MAX1639 Evaluation Kit

**Table 1. Jumper JU1 Functions**

SHUNT LOCATION	REF PIN	MAX1639 OUTPUT
ON	Connected to GND	Shutdown mode, $V_{OUT} = 0V$
OFF	Floating	MAX1639 enabled, $V_{OUT} = 2.5V$

**Table 2. Jumper JU2 Functions**

SHUNT LOCATION	FREQ PIN	SWITCHING FREQUENCY (kHz)
1 and 3	Connected to GND	300
1 and 2	Connected to REF	600
1 and 4	Connected to $V_{CC}$	1000

**Note:** 1MHz operation can affect the allowable output voltage range (due to duty factor limitations); it also affects soft-start and foldback current limiting (see the MAX1639 data sheet).

## Component Suppliers

SUPPLIER	PHONE	FAX
AVX	(803) 946-0690	(803) 626-3123
Central Semiconductor	(516) 435-1110	(516) 435-1824
Coilcraft	(847) 639-6400	(847) 639-1469
Dale-Vishay	(402) 564-3131	(402) 563-6418
Fairchild	(408) 721-2181	(408) 721-1635
International Rectifier	(310) 322-3331	(310) 322-3332
IRC	(512) 992-7900	(512) 992-3377
Motorola	(602) 303-5454	(602) 994-6430
Nihon	(805) 867-2555	(805) 867-2698
Sanyo	(619) 661-6835	(619) 661-1055
Sprague	(603) 224-1961	(603) 224-1430
Sumida	(847) 956-0666	(847) 956-0702
Taiyo Yuden	(408) 573-4150	(408) 573-4159
TDK	(847) 390-4373	(847) 390-4428
Vishay/Vitramon	(203) 268-6261	(203) 452-5670

**Note:** Please indicate that you are using the MAX1639 when contacting these component suppliers.

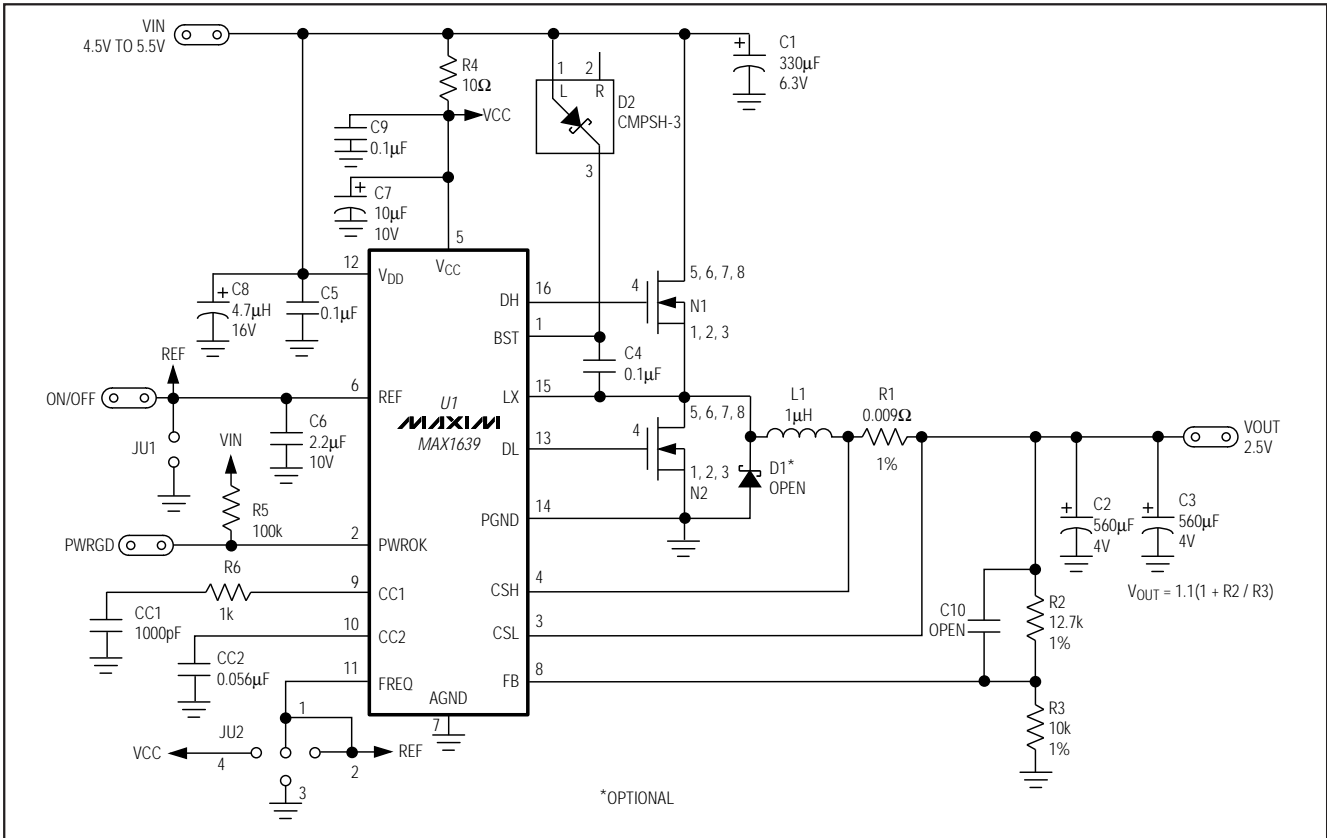

Figure 1. MAX1639 EV Kit Schematic Diagram

# MAX1639 Evaluation Kit

Evaluates: MAX1639

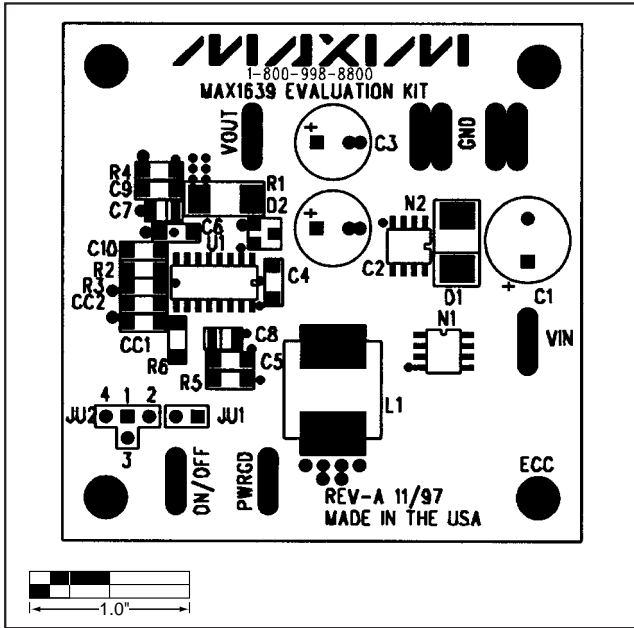

Figure 2. MAX1639 EV Kit Component Placement Guide—Component Side

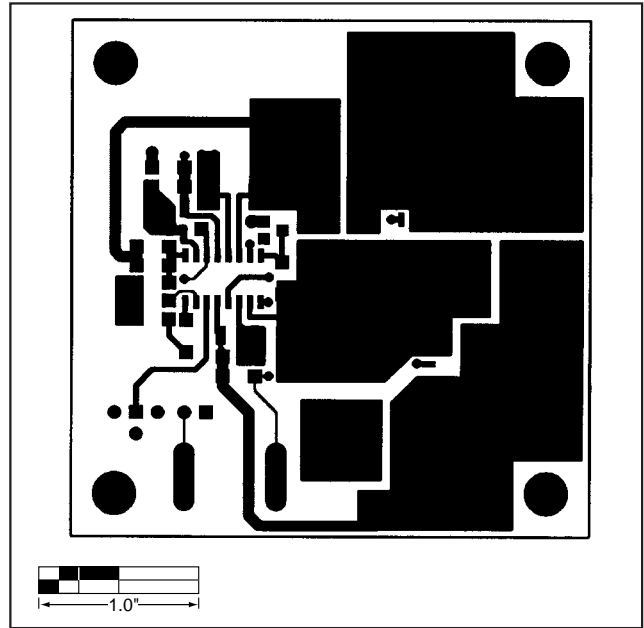

Figure 3. MAX1639 EV Kit PC Board Layout—Component Side

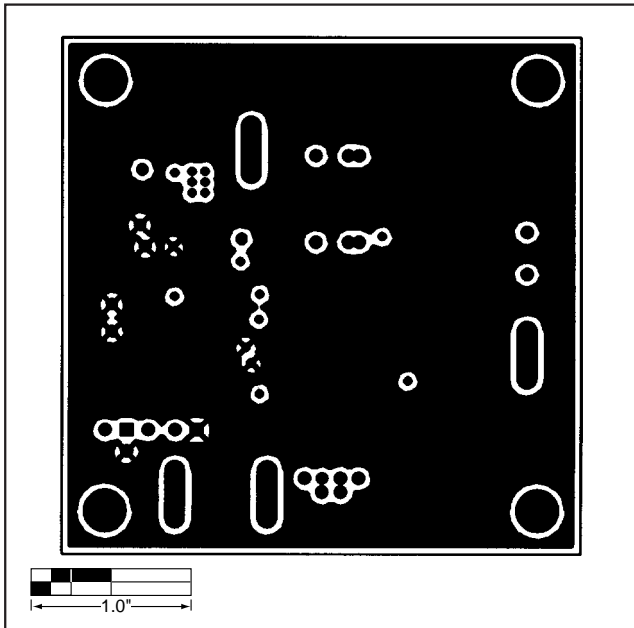

Figure 4. MAX1639 EV Kit PC Board Layout—Two Internal Ground Planes

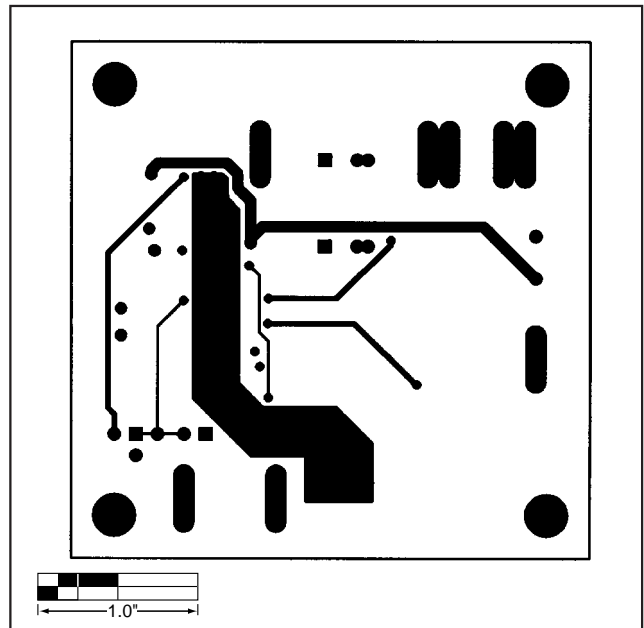

Figure 5. MAX1639 EV Kit PC Board Layout—Solder Side

Maxim cannot assume responsibility for use of any circuitry other than circuitry entirely embodied in a Maxim product. No circuit patent licenses are implied. Maxim reserves the right to change the circuitry and specifications without notice at any time.

3 \_\_\_\_\_ Maxim Integrated Products, 120 San Gabriel Drive, Sunnyvale, CA 94086 408-737-7600