**HIGH-PRECISION SMALL-PACKAGE
VOLTAGE DETECTOR**

S-808xxC Series

The S-808xxC series is a series of high-precision voltage detectors developed using CMOS process. The detection voltage is fixed internally with an accuracy of $\pm 2.0\%$. Two output forms, Nch open-drain and CMOS output, are available. Ultra-low current consumption and miniature package lineup can meet demand from the portable device applications.

■ Features

- Ultra-low current consumption
 - 1.3 μA Typ. (at $V_{DD}=1.5\text{ V}$) (Products with detection voltage of 1.4 V Typ. or less)
 - 0.8 μA Typ. (at $V_{DD}=3.5\text{ V}$) (Products with detection voltage of 1.5 V Typ. or more)
- High-accuracy detection voltage $\pm 2.0\%$
- Operating voltage range
 - 0.65 V to 5.0 V (Products with detection voltage of 1.4 V Typ. or less)
 - 0.95 V to 10.0 V (Products with detection voltage of 1.5 V Typ. or more)
- Hysteresis characteristics 5 % typ.
- Detection voltage 0.8 V to 6.0 V (0.1 V step)
- Output form Active low CMOS output or active low Nch open-drain

■ Applications

- Power monitor for portable equipment such as note book computers, digital cameras, PDA, and cellular phones.
- Constant voltage power monitor for cameras, video equipment and communication devices.
- Power monitor for microcomputers and reset for CPUs.
- Battery checker
- Detection of power failure

■ Packages

- 3-Pin SOT-89-3 (Package drawing code: UP003-A)
- 3-Pin TO-92 (Package drawing code: Yx *1003-A)
- 4-Pin SC-82AB (Package drawing code: NP004-A)
- 4-Pin SNB(B) (Package drawing code: BB004-A)
- 5-Pin SOT-23-5 (Package drawing code: MP005-A)

*1. x changes according to the packing form in TO-92 S; Bulk and F; Tape and Reel Z; Tape and ammo.

■ Block Diagrams

1. Active low Nch open-drain

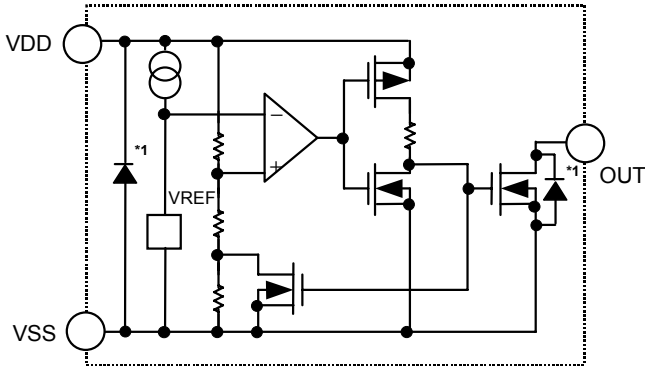

2. Active low CMOS output

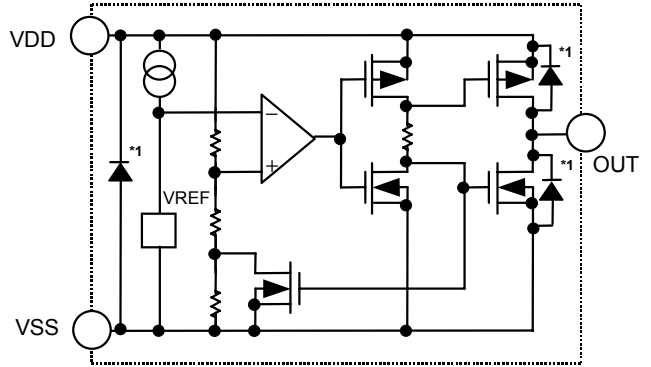

*1. Parasitic diode

Figure 1

■ **Pin Configuration**

See the attached drawings for details of the package.

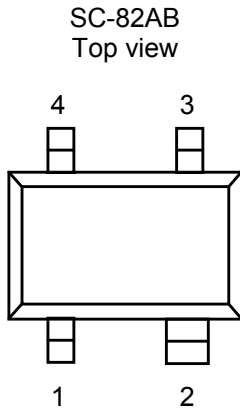

Figure 2

Table 1 Pin Description

No.	Symbol	Description
1	OUT	Voltage detection output pin
2	VDD	Voltage input pin
3	NC *1	Non-connected
4	VSS	Ground pin

*1. NC pin is electrically open.
Connecting this pin to VDD or VSS is allowed.

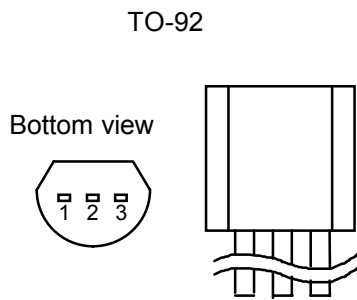

Figure 3

Table 2 Pin Description

No.	Symbol	Description
1	OUT	Voltage detection output pin
2	VDD	Voltage input pin
3	VSS	Ground pin

SOT-89-3
Top view

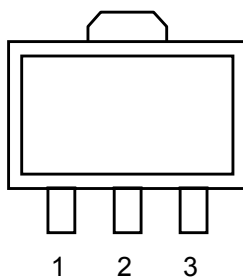

Figure 4

Table 3 Pin Description

No.	Symbol	Description
1	OUT	Voltage detection output pin
2	VDD	Voltage input pin
3	VSS	Ground pin

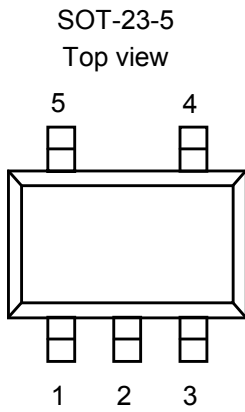

Figure 5

Table 4 Pin Description

No.	Symbol	Description
1	OUT	Voltage detection output pin
2	VDD	Voltage input pin
3	VSS	Ground pin
4	NC *1	Non-connected
5	NC *1	Non-connected

*1. NC Pin is electrically open.
 Connecting this pin to VDD or VSS is allowed.

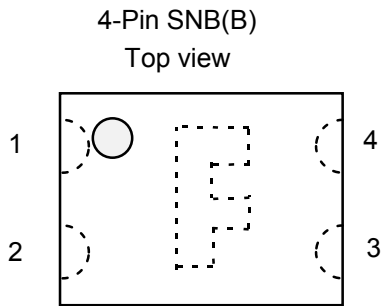

Figure 6

Table 5 Pin Description

No.	Symbol	Description
1	OUT	Voltage detection output pin
2	VSS	Ground pin
3	NC *1	Non-connected
4	VDD	Voltage input pin

*1. NC Pin is electrically open.
 Connecting this pin to VDD or VSS is allowed.

■ **Selection Guide**

1. Product Name

1-1 Package: 4-Pin SNB(B), SC-82AB, SOT-23-5, SOT-89-3

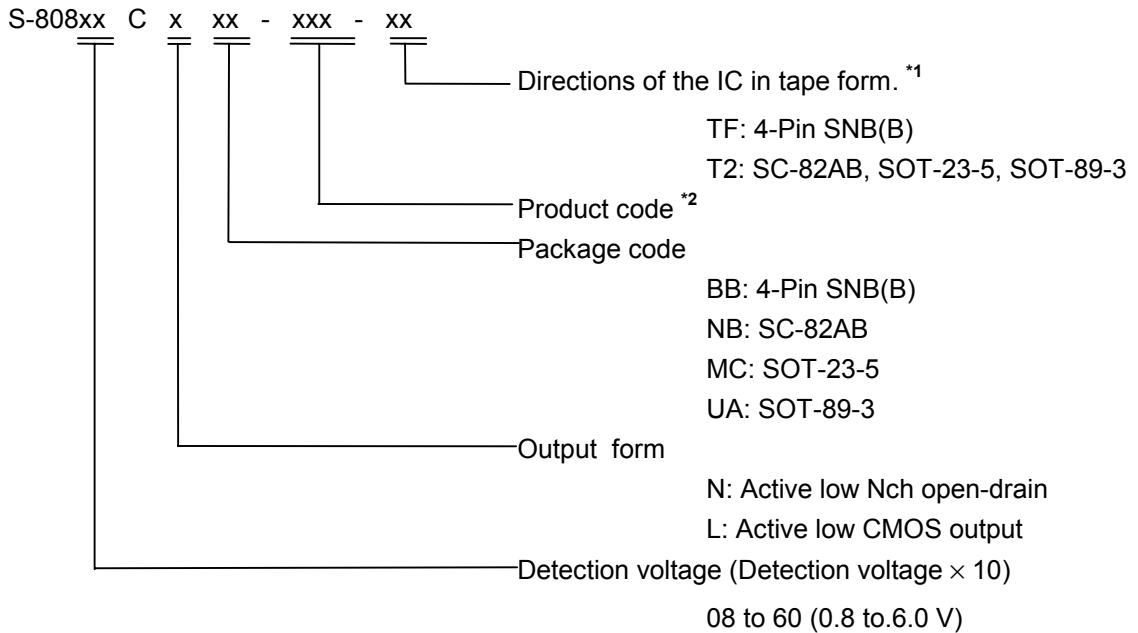

*1. Please refer taping drawings at the end this book for directions of this IC in tape form. TF and T2 are the standards.

*2. Please refer **Table 6** and **7** for product code.

1-2 Package: TO-92

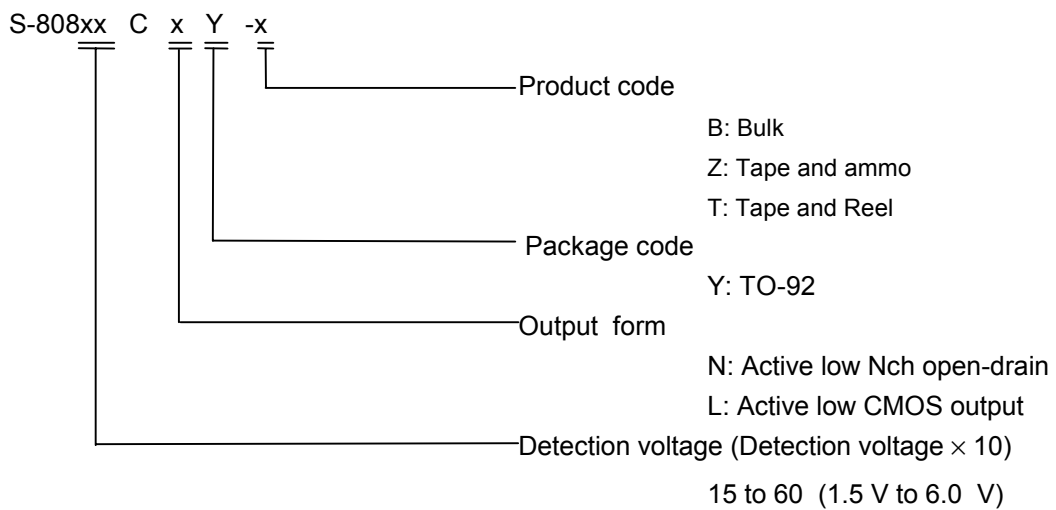

2. Product Name List

2-1 Active Low Nch Open-drain

Table 6 Selection Guide

Detection voltage range	Hysteresis width (typ.)	SC-82AB	TO-92 *2	SOT-89-3	SOT-23-5	4-Pin SNB(B)
0.8 V±2.0%	0.034V	S-80808CNNB-B9M-T2	—	—	—	S-80808CNBB-B9M-TF
0.9 V±2.0%	0.044V	S-80809CNNB-B9N-T2	—	—	—	S-80809CNBB-B9N-TF
1.0 V±2.0%	0.054V	S-80810CNNB-B9O-T2	—	—	—	S-80810CNBB-B9O-TF
1.1 V±2.0%	0.064V	S-80811CNNB-B9P-T2	—	—	—	S-80811CNBB-B9P-TF
1.2 V±2.0%	0.073V	S-80812CNNB-B9Q-T2	—	—	—	S-80812CNBB-B9Q-TF
1.3 V±2.0%	0.083V	S-80813CNNB-B9R-T2	—	—	—	S-80813CNBB-B9R-TF
1.4 V±2.0%	0.093V	S-80814CNNB-B9S-T2	—	—	—	S-80814CNBB-B9S-TF
1.5 V±2.0%	0.075 V	S-80815CNNB-B8A-T2	S-80815CNY-x	S-80815CNUA-B8A-T2	S-80815CNMC-B8A-T2	S-80815CNBB-B8A-TF
1.6 V±2.0%	0.080 V	S-80816CNNB-B8B-T2	S-80816CNY-x	S-80816CNUA-B8B-T2	S-80816CNMC-B8B-T2	S-80816CNBB-B8B-TF
1.7 V±2.0%	0.085 V	S-80817CNNB-B8C-T2	S-80817CNY-x	S-80817CNUA-B8C-T2	S-80817CNMC-B8C-T2	S-80817CNBB-B8C-TF
1.8 V±2.0%	0.090 V	S-80818CNNB-B8D-T2	S-80818CNY-x	S-80818CNUA-B8D-T2	S-80818CNMC-B8D-T2	S-80818CNBB-B8D-TF
1.9 V±2.0%	0.095 V	S-80819CNNB-B8E-T2	S-80819CNY-x	S-80819CNUA-B8E-T2	S-80819CNMC-B8E-T2	S-80819CNBB-B8E-TF
2.0 V±2.0%	0.100 V	S-80820CNNB-B8F-T2	S-80820CNY-x	S-80820CNUA-B8F-T2	S-80820CNMC-B8F-T2	S-80820CNBB-B8F-TF
2.1 V±2.0%	0.105 V	S-80821CNNB-B8G-T2	S-80821CNY-x	S-80821CNUA-B8G-T2	S-80821CNMC-B8G-T2	S-80821CNBB-B8G-TF
2.2 V±2.0%	0.110 V	S-80822CNNB-B8H-T2	S-80822CNY-x	S-80822CNUA-B8H-T2	S-80822CNMC-B8H-T2	S-80822CNBB-B8H-TF
2.3 V±2.0%	0.115 V	S-80823CNNB-B8I-T2	S-80823CNY-x	S-80823CNUA-B8I-T2	S-80823CNMC-B8I-T2	S-80823CNBB-B8I-TF
2.4 V±2.0%	0.120 V	S-80824CNNB-B8J-T2	S-80824CNY-x	S-80824CNUA-B8J-T2	S-80824CNMC-B8J-T2	S-80824CNBB-B8J-TF
2.4 V typ.	4.4±0.1 V *3	—	S-80824KNY-x *1	S-80824KNUA-D2B-T2 *1	—	—
2.5 V±2.0%	0.125 V	S-80825CNNB-B8K-T2	S-80825CNY-x	S-80825CNUA-B8K-T2	S-80825CNMC-B8K-T2	S-80825CNBB-B8K-TF
2.6 V±2.0%	0.130 V	S-80826CNNB-B8L-T2	S-80826CNY-x	S-80826CNUA-B8L-T2	S-80826CNMC-B8L-T2	S-80826CNBB-B8L-TF
2.7 V±2.0%	0.135 V	S-80827CNNB-B8M-T2	S-80827CNY-x	S-80827CNUA-B8M-T2	S-80827CNMC-B8M-T2	S-80827CNBB-B8M-TF
2.8 V±2.0%	0.140 V	S-80828CNNB-B8N-T2	S-80828CNY-x	S-80828CNUA-B8N-T2	S-80828CNMC-B8N-T2	S-80828CNBB-B8N-TF
2.9 V±2.0%	0.145 V	S-80829CNNB-B8O-T2	S-80829CNY-x	S-80829CNUA-B8O-T2	S-80829CNMC-B8O-T2	S-80829CNBB-B8O-TF
3.0 V±2.0%	0.150 V	S-80830CNNB-B8P-T2	S-80830CNY-x	S-80830CNUA-B8P-T2	S-80830CNMC-B8P-T2	S-80830CNBB-B8P-TF
3.1 V±2.0%	0.155 V	S-80831CNNB-B8Q-T2	S-80831CNY-x	S-80831CNUA-B8Q-T2	S-80831CNMC-B8Q-T2	S-80831CNBB-B8Q-TF
3.2 V±2.0%	0.160 V	S-80832CNNB-B8R-T2	S-80832CNY-x	S-80832CNUA-B8R-T2	S-80832CNMC-B8R-T2	S-80832CNBB-B8R-TF
3.3 V±2.0%	0.165 V	S-80833CNNB-B8S-T2	S-80833CNY-x	S-80833CNUA-B8S-T2	S-80833CNMC-B8S-T2	S-80833CNBB-B8S-TF
3.4 V±2.0%	0.170 V	S-80834CNNB-B8T-T2	S-80834CNY-x	S-80834CNUA-B8T-T2	S-80834CNMC-B8T-T2	S-80834CNBB-B8T-TF
3.5 V±2.0%	0.175 V	S-80835CNNB-B8U-T2	S-80835CNY-x	S-80835CNUA-B8U-T2	S-80835CNMC-B8U-T2	S-80835CNBB-B8U-TF
3.6 V±2.0%	0.180 V	S-80836CNNB-B8V-T2	S-80836CNY-x	S-80836CNUA-B8V-T2	S-80836CNMC-B8V-T2	S-80836CNBB-B8V-TF
3.7 V±2.0%	0.185 V	S-80837CNNB-B8W-T2	S-80837CNY-x	S-80837CNUA-B8W-T2	S-80837CNMC-B8W-T2	S-80837CNBB-B8W-TF
3.8 V±2.0%	0.190 V	S-80838CNNB-B8X-T2	S-80838CNY-x	S-80838CNUA-B8X-T2	S-80838CNMC-B8X-T2	S-80838CNBB-B8X-TF
3.9 V±2.0%	0.195 V	S-80839CNNB-B8Y-T2	S-80839CNY-x	S-80839CNUA-B8Y-T2	S-80839CNMC-B8Y-T2	S-80839CNBB-B8Y-TF
4.0 V±2.0%	0.200 V	S-80840CNNB-B8Z-T2	S-80840CNY-x	S-80840CNUA-B8Z-T2	S-80840CNMC-B8Z-T2	S-80840CNBB-B8Z-TF
4.1 V±2.0%	0.205 V	S-80841CNNB-B82-T2	S-80841CNY-x	S-80841CNUA-B82-T2	S-80841CNMC-B82-T2	S-80841CNBB-B82-TF
4.2 V±2.0%	0.210 V	S-80842CNNB-B83-T2	S-80842CNY-x	S-80842CNUA-B83-T2	S-80842CNMC-B83-T2	S-80842CNBB-B83-TF
4.3 V±2.0%	0.215 V	S-80843CNNB-B84-T2	S-80843CNY-x	S-80843CNUA-B84-T2	S-80843CNMC-B84-T2	S-80843CNBB-B84-TF
4.4 V±2.0%	0.220 V	S-80844CNNB-B85-T2	S-80844CNY-x	S-80844CNUA-B85-T2	S-80844CNMC-B85-T2	S-80844CNBB-B85-TF
4.5 V±2.0%	0.225 V	S-80845CNNB-B86-T2	S-80845CNY-x	S-80845CNUA-B86-T2	S-80845CNMC-B86-T2	S-80845CNBB-B86-TF
4.6 V±2.0%	0.230 V	S-80846CNNB-B87-T2	S-80846CNY-x	S-80846CNUA-B87-T2	S-80846CNMC-B87-T2	S-80846CNBB-B87-TF
4.6 V±0.10 V	0.10 V max.	—	S-80846KNY-x *1	S-80846KNUA-D2C-T2 *1	—	—
4.7 V±2.0%	0.235 V	S-80847CNNB-B88-T2	S-80847CNY-x	S-80847CNUA-B88-T2	S-80847CNMC-B88-T2	S-80847CNBB-B88-TF
4.8 V±2.0%	0.240 V	S-80848CNNB-B89-T2	S-80848CNY-x	S-80848CNUA-B89-T2	S-80848CNMC-B89-T2	S-80848CNBB-B89-TF
4.9 V±2.0%	0.245 V	S-80849CNNB-B9A-T2	S-80849CNY-x	S-80849CNUA-B9A-T2	S-80849CNMC-B9A-T2	S-80849CNBB-B9A-TF
5.0 V±2.0%	0.250 V	S-80850CNNB-B9B-T2	S-80850CNY-x	S-80850CNUA-B9B-T2	S-80850CNMC-B9B-T2	S-80850CNBB-B9B-TF
5.1 V±2.0%	0.255 V	S-80851CNNB-B9C-T2	S-80851CNY-x	S-80851CNUA-B9C-T2	S-80851CNMC-B9C-T2	S-80851CNBB-B9C-TF
5.2 V±2.0%	0.260 V	S-80852CNNB-B9D-T2	S-80852CNY-x	S-80852CNUA-B9D-T2	S-80852CNMC-B9D-T2	S-80852CNBB-B9D-TF
5.3 V±2.0%	0.265 V	S-80853CNNB-B9E-T2	S-80853CNY-x	S-80853CNUA-B9E-T2	S-80853CNMC-B9E-T2	S-80853CNBB-B9E-TF
5.4 V±2.0%	0.270 V	S-80854CNNB-B9F-T2	S-80854CNY-x	S-80854CNUA-B9F-T2	S-80854CNMC-B9F-T2	S-80854CNBB-B9F-TF
5.5 V±2.0%	0.275 V	S-80855CNNB-B9G-T2	S-80855CNY-x	S-80855CNUA-B9G-T2	S-80855CNMC-B9G-T2	S-80855CNBB-B9G-TF
5.6 V±2.0%	0.280 V	S-80856CNNB-B9H-T2	S-80856CNY-x	S-80856CNUA-B9H-T2	S-80856CNMC-B9H-T2	S-80856CNBB-B9H-TF
5.7 V±2.0%	0.285 V	S-80857CNNB-B9I-T2	S-80857CNY-x	S-80857CNUA-B9I-T2	S-80857CNMC-B9I-T2	S-80857CNBB-B9I-TF
5.8 V±2.0%	0.290 V	S-80858CNNB-B9J-T2	S-80858CNY-x	S-80858CNUA-B9J-T2	S-80858CNMC-B9J-T2	S-80858CNBB-B9J-TF
5.9 V±2.0%	0.295 V	S-80859CNNB-B9K-T2	S-80859CNY-x	S-80859CNUA-B9K-T2	S-80859CNMC-B9K-T2	S-80859CNBB-B9K-TF
6.0 V±2.0%	0.300 V	S-80860CNNB-B9L-T2	S-80860CNY-x	S-80860CNUA-B9L-T2	S-80860CNMC-B9L-T2	S-80860CNBB-B9L-TF

*1. Please refer to the Table 13 or 15 in the Electrical Characteristics.

*2. x changes according to the packing form in TO-92. B; Bulk and T; Tape and Reel and Z; Tape and ammo.

*3. Describes the release voltage.

HIGH-PRECISION SMALL PACKAGE VOLTAGE DETECTOR S-808xxC Series

Rev.2.0_31

2-2 Active Low CMOS output

Table 7 Selection Guide

Detection voltage range	Hysteresis width (typ.)	SC-82AB	TO-92 ^{*2}	SOT-89-3	SOT-23-5	4-Pin SNB(B)
0.8 V± 2.0%	0.034 V	S-80808CLNB-B7M-T2	—	—	—	S-80808CLBB-B7M-TF
0.9 V± 2.0%	0.044 V	S-80809CLNB-B7N-T2	—	—	—	S-80809CLBB-B7N-TF
1.0 V± 2.0%	0.054 V	S-80810CLNB-B7O-T2	—	—	—	S-80810CLBB-B7O-TF
1.1 V± 2.0%	0.064 V	S-80811CLNB-B7P-T2	—	—	—	S-80811CLBB-B7P-TF
1.2 V± 2.0%	0.073 V	S-80812CLNB-B7Q-T2	—	—	—	S-80812CLBB-B7Q-TF
1.3 V± 2.0%	0.083 V	S-80813CLNB-B7R-T2	—	—	—	S-80813CLBB-B7R-TF
1.4 V± 2.0%	0.093 V	S-80814CLNB-B7S-T2	—	—	—	S-80814CLBB-B7S-TF
1.5 V± 2.0%	0.075 V	S-80815CLNB-B6A-T2	S-80815CLY-x	S-80815CLUA-B6A-T2	S-80815CLMC-B6A-T2	S-80815CLBB-B6A-TF
1.6 V± 2.0%	0.080 V	S-80816CLNB-B6B-T2	S-80816CLY-x	S-80816CLUA-B6B-T2	S-80816CLMC-B6B-T2	S-80816CLBB-B6B-TF
1.7 V± 2.0%	0.085 V	S-80817CLNB-B6C-T2	S-80817CLY-x	S-80817CLUA-B6C-T2	S-80817CLMC-B6C-T2	S-80817CLBB-B6C-TF
1.8 V± 2.0%	0.090 V	S-80818CLNB-B6D-T2	S-80818CLY-x	S-80818CLUA-B6D-T2	S-80818CLMC-B6D-T2	S-80818CLBB-B6D-TF
1.9 V± 2.0%	0.095 V	S-80819CLNB-B6E-T2	S-80819CLY-x	S-80819CLUA-B6E-T2	S-80819CLMC-B6E-T2	S-80819CLBB-B6E-TF
2.0 V± 2.0%	0.100 V	S-80820CLNB-B6F-T2	S-80820CLY-x	S-80820CLUA-B6F-T2	S-80820CLMC-B6F-T2	S-80820CLBB-B6F-TF
2.1 V± 2.0%	0.105 V	S-80821CLNB-B6G-T2	S-80821CLY-x	S-80821CLUA-B6G-T2	S-80821CLMC-B6G-T2	S-80821CLBB-B6G-TF
2.2 V± 2.0%	0.110 V	S-80822CLNB-B6H-T2	S-80822CLY-x	S-80822CLUA-B6H-T2	S-80822CLMC-B6H-T2	S-80822CLBB-B6H-TF
2.3 V± 2.0%	0.115 V	S-80823CLNB-B6I-T2	S-80823CLY-x	S-80823CLUA-B6I-T2	S-80823CLMC-B6I-T2	S-80823CLBB-B6I-TF
2.4 V± 2.0%	0.120 V	S-80824CLNB-B6J-T2	S-80824CLY-x	S-80824CLUA-B6J-T2	S-80824CLMC-B6J-T2	S-80824CLBB-B6J-TF
2.5 V± 2.0%	0.125 V	S-80825CLNB-B6K-T2	S-80825CLY-x	S-80825CLUA-B6K-T2	S-80825CLMC-B6K-T2	S-80825CLBB-B6K-TF
2.6 V± 2.0%	0.130 V	S-80826CLNB-B6L-T2	S-80826CLY-x	S-80826CLUA-B6L-T2	S-80826CLMC-B6L-T2	S-80826CLBB-B6L-TF
2.7 V± 2.0%	0.135 V	S-80827CLNB-B6M-T2	S-80827CLY-x	S-80827CLUA-B6M-T2	S-80827CLMC-B6M-T2	S-80827CLBB-B6M-TF
2.8 V± 2.0%	0.140 V	S-80828CLNB-B6N-T2	S-80828CLY-x	S-80828CLUA-B6N-T2	S-80828CLMC-B6N-T2	S-80828CLBB-B6N-TF
2.9 V± 2.0%	0.145 V	S-80829CLNB-B6O-T2	S-80829CLY-x	S-80829CLUA-B6O-T2	S-80829CLMC-B6O-T2	S-80829CLBB-B6O-TF
3.0 V± 2.0%	0.150 V	S-80830CLNB-B6P-T2	S-80830CLY-x	S-80830CLUA-B6P-T2	S-80830CLMC-B6P-T2	S-80830CLBB-B6P-TF
3.1 V± 2.0%	0.155 V	S-80831CLNB-B6Q-T2	S-80831CLY-x	S-80831CLUA-B6Q-T2	S-80831CLMC-B6Q-T2	S-80831CLBB-B6Q-TF
3.2 V± 2.0%	0.160 V	S-80832CLNB-B6R-T2	S-80832CLY-x	S-80832CLUA-B6R-T2	S-80832CLMC-B6R-T2	S-80832CLBB-B6R-TF
3.3 V± 2.0%	0.165 V	S-80833CLNB-B6S-T2	S-80833CLY-x	S-80833CLUA-B6S-T2	S-80833CLMC-B6S-T2	S-80833CLBB-B6S-TF
3.4 V± 2.0%	0.170 V	S-80834CLNB-B6T-T2	S-80834CLY-x	S-80834CLUA-B6T-T2	S-80834CLMC-B6T-T2	S-80834CLBB-B6T-TF
3.5 V± 2.0%	0.175 V	S-80835CLNB-B6U-T2	S-80835CLY-x	S-80835CLUA-B6U-T2	S-80835CLMC-B6U-T2	S-80835CLBB-B6U-TF
3.6 V± 2.0%	0.180 V	S-80836CLNB-B6V-T2	S-80836CLY-x	S-80836CLUA-B6V-T2	S-80836CLMC-B6V-T2	S-80836CLBB-B6V-TF
3.7 V± 2.0%	0.185 V	S-80837CLNB-B6W-T2	S-80837CLY-x	S-80837CLUA-B6W-T2	S-80837CLMC-B6W-T2	S-80837CLBB-B6W-TF
3.8 V± 2.0%	0.190 V	S-80838CLNB-B6X-T2	S-80838CLY-x	S-80838CLUA-B6X-T2	S-80838CLMC-B6X-T2	S-80838CLBB-B6X-TF
3.9 V± 2.0%	0.195 V	S-80839CLNB-B6Y-T2	S-80839CLY-x	S-80839CLUA-B6Y-T2	S-80839CLMC-B6Y-T2	S-80839CLBB-B6Y-TF
4.0 V± 2.0%	0.200 V	S-80840CLNB-B6Z-T2	S-80840CLY-x	S-80840CLUA-B6Z-T2	S-80840CLMC-B6Z-T2	S-80840CLBB-B6Z-TF
4.1 V± 2.0%	0.205 V	S-80841CLNB-B62-T2	S-80841CLY-x	S-80841CLUA-B62-T2	S-80841CLMC-B62-T2	S-80841CLBB-B62-TF
4.2 V± 2.0%	0.210 V	S-80842CLNB-B63-T2	S-80842CLY-x	S-80842CLUA-B63-T2	S-80842CLMC-B63-T2	S-80842CLBB-B63-TF
4.3 V± 2.0%	0.215 V	S-80843CLNB-B64-T2	S-80843CLY-x	S-80843CLUA-B64-T2	S-80843CLMC-B64-T2	S-80843CLBB-B64-TF
4.4 V± 2.0%	0.220 V	S-80844CLNB-B65-T2	S-80844CLY-x	S-80844CLUA-B65-T2	S-80844CLMC-B65-T2	S-80844CLBB-B65-TF
4.45 V typ.	4.70 V max. ^{*3}	—	S-80844KLY-x ^{*1}	S-80844KLUA-D2A-T2 ^{*1}	—	—
4.5 V± 2.0%	0.225 V	S-80845CLNB-B66-T2	S-80845CLY-x	S-80845CLUA-B66-T2	S-80845CLMC-B66-T2	S-80845CLBB-B66-TF
4.6 V± 2.0%	0.230 V	S-80846CLNB-B67-T2	S-80846CLY-x	S-80846CLUA-B67-T2	S-80846CLMC-B67-T2	S-80846CLBB-B67-TF
4.7 V± 2.0%	0.235 V	S-80847CLNB-B68-T2	S-80847CLY-x	S-80847CLUA-B68-T2	S-80847CLMC-B68-T2	S-80847CLBB-B68-TF
4.8 V± 2.0%	0.240 V	S-80848CLNB-B69-T2	S-80848CLY-x	S-80848CLUA-B69-T2	S-80848CLMC-B69-T2	S-80848CLBB-B69-TF
4.9 V± 2.0%	0.245 V	S-80849CLNB-B7A-T2	S-80849CLY-x	S-80849CLUA-B7A-T2	S-80849CLMC-B7A-T2	S-80849CLBB-B7A-TF
5.0 V± 2.0%	0.250 V	S-80850CLNB-B7B-T2	S-80850CLY-x	S-80850CLUA-B7B-T2	S-80850CLMC-B7B-T2	S-80850CLBB-B7B-TF
5.1 V± 2.0%	0.255 V	S-80851CLNB-B7C-T2	S-80851CLY-x	S-80851CLUA-B7C-T2	S-80851CLMC-B7C-T2	S-80851CLBB-B7C-TF
5.2 V± 2.0%	0.260 V	S-80852CLNB-B7D-T2	S-80852CLY-x	S-80852CLUA-B7D-T2	S-80852CLMC-B7D-T2	S-80852CLBB-B7D-TF
5.3 V± 2.0%	0.265 V	S-80853CLNB-B7E-T2	S-80853CLY-x	S-80853CLUA-B7E-T2	S-80853CLMC-B7E-T2	S-80853CLBB-B7E-TF
5.4 V± 2.0%	0.270 V	S-80854CLNB-B7F-T2	S-80854CLY-x	S-80854CLUA-B7F-T2	S-80854CLMC-B7F-T2	S-80854CLBB-B7F-TF
5.5 V± 2.0%	0.275 V	S-80855CLNB-B7G-T2	S-80855CLY-x	S-80855CLUA-B7G-T2	S-80855CLMC-B7G-T2	S-80855CLBB-B7G-TF
5.6 V± 2.0%	0.280 V	S-80856CLNB-B7H-T2	S-80856CLY-x	S-80856CLUA-B7H-T2	S-80856CLMC-B7H-T2	S-80856CLBB-B7H-TF
5.7 V± 2.0%	0.285 V	S-80857CLNB-B7I-T2	S-80857CLY-x	S-80857CLUA-B7I-T2	S-80857CLMC-B7I-T2	S-80857CLBB-B7I-TF
5.8 V± 2.0%	0.290 V	S-80858CLNB-B7J-T2	S-80858CLY-x	S-80858CLUA-B7J-T2	S-80858CLMC-B7J-T2	S-80858CLBB-B7J-TF
5.9 V± 2.0%	0.295 V	S-80859CLNB-B7K-T2	S-80859CLY-x	S-80859CLUA-B7K-T2	S-80859CLMC-B7K-T2	S-80859CLBB-B7K-TF
6.0 V± 2.0%	0.300 V	S-80860CLNB-B7L-T2	S-80860CLY-x	S-80860CLUA-B7L-T2	S-80860CLMC-B7L-T2	S-80860CLBB-B7L-TF

*1. Please refer to the **Table 14** in the Electrical Characteristics.

*2. x changes according to the packing form in TO-92. B; Bulk and T; Tape and Reel and Z; Tape and ammo.

*3. Describes the release voltage.

■ **Output Forms**

1. **Output forms in S-808xxC Series**

	Nch open-drain (Active low)	CMOS output(Active low)
S-808xxC Series	“N” is the last letter of the Product Name. e.g. S-80815CN	“L” is the last letter of the Product Name. e.g. S-80815CL

2. **Output forms and their usage**

Usage	Nch (“L”)	CMOS (“L”)
Different power supplies	Yes	No
Active low reset for CPUs	Yes	Yes
Active high reset for CPUs	No	No
Detection voltage change by resistor divider	Yes	No

- Example for two power supplies
- Examples for one power supply

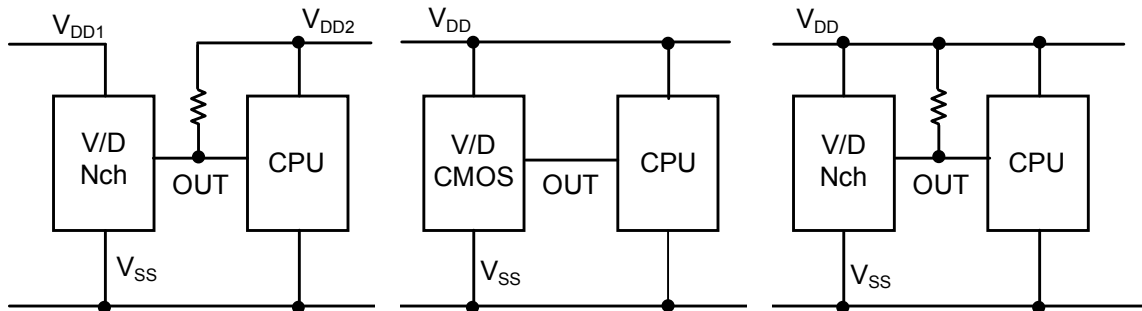

Figure 7

■ Absolute Maximum Ratings

Table 8

1. Products with detection voltage Typ. 1.4 V or less

(Unless otherwise specified :Ta=25°C)

Parameter	Symbol	Ratings	Unit
Power supply voltage	$V_{DD}-V_{SS}$	7	V
Output voltage	Nch open-drain	V_{OUT}	V
	CMOS output		
		$V_{SS}-0.3$ to $V_{SS}+7$	
		$V_{SS}-0.3$ to $V_{DD}+0.3$	
Output current	I_{OUT}	50	mA
Power dissipation	P_D	SC-82AB	150
		4-Pin SNB(B)	60
Operating temperature	T_{opr}	-40 to +85	°C
Storage temperature	T_{stg}	-40 to +125	°C

2. Products with detection voltage Typ. 1.5 V or more

(Unless otherwise specified :Ta=25°C)

Parameter	Symbol	Ratings	Unit
Power supply voltage	$V_{DD}-V_{SS}$	12	V
Output voltage	Nch open-drain	V_{OUT}	V
	CMOS output		
		$V_{SS}-0.3$ to $V_{SS}+12$	
		$V_{SS}-0.3$ to $V_{DD}+0.3$	
Output current	I_{OUT}	50	mA
Power dissipation	P_D	TO-92	400
		SOT-89-3	500
		SOT-23-5	250
		SC-82AB	150
		4-Pin SNB(B)	60
Operating temperature	T_{opr}	-40 to +85	°C
Storage temperature	T_{stg}	-40 to +125	°C

Caution The absolute maximum ratings are rated values exceeding which the product could suffer physical damage. These values must therefore not be exceeded under any conditions.

■ Electrical Characteristics

1. Nch open-drain products (Detection voltage Typ.1.4 V or less)

Table 9

(Unless otherwise specified :Ta=25°C)

Parameter	Symbol	Conditions	Min.	Typ.	Max.	Units	Test circuit	
Detection voltage *1	-V _{DET}	S-80808	0.784	0.800	0.816	V	1	
		S-80809	0.882	0.900	0.918			
		S-80810	0.980	1.000	1.020			
		S-80811	1.078	1.100	1.122			
		S-80812	1.176	1.200	1.224			
		S-80813	1.274	1.300	1.326			
		S-80814	1.372	1.400	1.428			
Release voltage	+V _{DET}	S-80808	0.802	0.834	0.867	V	1	
		S-80809	0.910	0.944	0.979			
		S-80810	1.017	1.054	1.091			
		S-80811	1.125	1.164	1.203			
		S-80812	1.232	1.273	1.315			
		S-80813	1.340	1.383	1.427			
		S-80814	1.448	1.493	1.538			
Hysteresis width	V _{HYS}	S-80808	0.018	0.034	0.051	V	1	
		S-80809	0.028	0.044	0.061			
		S-80810	0.037	0.054	0.071			
		S-80811	0.047	0.064	0.081			
		S-80812	0.056	0.073	0.091			
		S-80813	0.066	0.083	0.101			
		S-80814	0.076	0.093	0.110			
Current consumption	I _{SS}	V _{DD} =1.5 V	S-80808 to 09	—	1.3	3.5	μA	2
		V _{DD} =2.0 V	S-80810 to 14	—	1.3	3.5		
Operating voltage	V _{DD}	S-80808 to 14		0.65	—	5.0	V	1
Output current of output transistor	I _{OUT}	Nch V _{DS} =0.5 V	V _{DD} =0.7 V S-80808 to 14	0.04	0.2	—	mA	3
Leakage current of output transistor	I _{LEAK}	Nch	V _{DS} =5.0V, V _{DD} =5.0 V S-80808 to 14	—	—	60	nA	3
Response time	t _{PLH}	—		—	—	60	μs	1
Temperature coefficient for detection voltage *2	$\frac{\Delta - V_{DET}}{\Delta Ta \cdot -V_{DET}}$	Ta=-40°C to +85°C		—	±100	±350	ppm/°C	1

*1. -V_{DET} : Actual detection voltage value

*2. Temperature change ratio for the detection voltage [mV/°C] is calculated using the following equation.

$$\frac{\Delta - V_{DET}}{\Delta Ta} [mV/°C] = -V_{DET(S)} [V] \times \frac{\Delta - V_{DET}}{\Delta Ta \cdot -V_{DET}} [ppm/°C] \div 1000$$

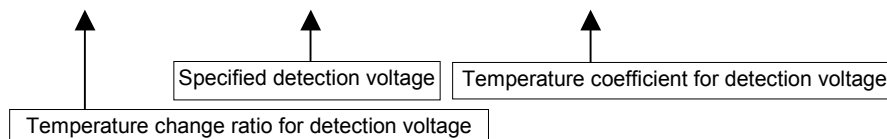

2. Nch open-drain products (Detection voltage Typ.1.5 V or more)

Table 10

(Unless otherwise specified :Ta=25°C)

Parameter	Symbol	Conditions		Min.	Typ.	Max.	Units	Test circuit
Detection voltage *1	-V _{DET}	—		-V _{DET(S)} ×0.98	-V _{DET(S)}	-V _{DET(S)} ×1.02	V	1
Hysteresis width	V _{HYS}	—		-V _{DET} ×0.03	-V _{DET} ×0.05	-V _{DET} ×0.08	V	1
Current consumption	I _{SS}	V _{DD} =3.5 V	S-80815 to 26	—	0.8	2.4	μA	2
		V _{DD} =4.5 V	S-80827 to 39	—	0.8	2.4		
		V _{DD} =6.0 V	S-80840 to 56	—	0.9	2.7		
		V _{DD} =7.5 V	S-80857 to 60	—	0.9	2.7		
Operating voltage	V _{DD}	S-80815 to 60		0.95	—	10.0	V	1
Output current of output transistor	I _{OUT}	Nch V _{DS} =0.5 V	V _{DD} =1.2 V S-80815 to 60	0.59	1.36	—	mA	3
			V _{DD} =2.4 V S-80827 to 60	2.88	4.98	—		
Leakage current of output transistor	I _{LEAK}	Nch	V _{DS} = 10.0 V, V _{DD} =10.0 V S-80815 to 60	—	—	100	nA	3
Response time	t _{PLH}	—		—	—	60	μs	1
Temperature coefficient for detection voltage *2	$\frac{\Delta - V_{DET}}{\Delta Ta \bullet -V_{DET}}$	Ta=-40°C to +85°C		—	±100	±350	ppm/°C	1

*1. -V_{DET} : Actual detection voltage value

-V_{DET(S)}: Specified detection voltage value (The center value of the detection voltage range in **Table 6** and **Table 7**)

*2. Temperature change ratio for the detection voltage [mV/°C] is calculated using the following equation.

$$\frac{\Delta - V_{DET}}{\Delta Ta} [mV/°C] = -V_{DET(S)} [V] \times \frac{\Delta - V_{DET}}{\Delta Ta \bullet -V_{DET}} [ppm/°C] \div 1000$$

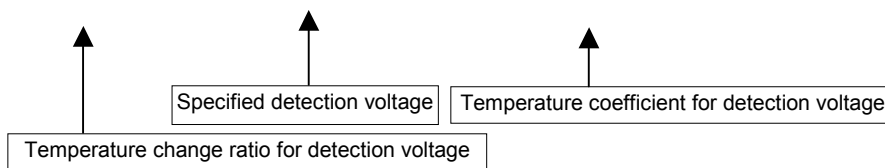

3. CMOS output products (Detection voltage Typ.1.4 V or less)

Table 11

(Unless otherwise specified :Ta=25°C)

Parameter	Symbol	Conditions	Min.	Typ.	Max.	Units	Test circuit	
Detection voltage *1	-V _{DET}	S-80808	0.784	0.800	0.816	V	1	
		S-80809	0.882	0.900	0.918			
		S-80810	0.980	1.000	1.020			
		S-80811	1.078	1.100	1.122			
		S-80812	1.176	1.200	1.224			
		S-80813	1.274	1.300	1.326			
		S-80814	1.372	1.400	1.428			
Release voltage	+V _{DET}	S-80808	0.802	0.834	0.867	V	1	
		S-80809	0.910	0.944	0.979			
		S-80810	1.017	1.054	1.091			
		S-80811	1.125	1.164	1.203			
		S-80812	1.232	1.273	1.315			
		S-80813	1.340	1.383	1.427			
		S-80814	1.448	1.493	1.538			
Hysteresis width	V _{HYS}	S-80808	0.018	0.034	0.051	V	1	
		S-80809	0.028	0.044	0.061			
		S-80810	0.037	0.054	0.071			
		S-80811	0.047	0.064	0.081			
		S-80812	0.056	0.073	0.091			
		S-80813	0.066	0.083	0.101			
		S-80814	0.076	0.093	0.110			
Current consumption	I _{SS}	V _{DD} =1.5 V	S-80808 to 09	—	1.3	3.5	μA	2
		V _{DD} =2.0 V	S-80810 to 14	—	1.3	3.5		
Operating voltage	V _{DD}	S-80808 to 14		0.65	—	5.0	V	1
Output current of output transistor	I _{OUT}	Nch V _{DS} =0.5 V	V _{DD} =0.7 V S-80808 to 14	0.04	0.2	—	mA	3
		Pch V _{DS} =2.1 V	V _{DD} =4.5 V S-80808 to 14	2.9	5.8	—		4
Response time	t _{PLH}	—		—	—	60	μs	1
Temperature coefficient for detection voltage *2	$\frac{\Delta - V_{DET}}{\Delta Ta \cdot -V_{DET}}$	Ta=-40°C to +85°C		—	±100	±350	ppm/°C	1

*1. -V_{DET} : Actual detection voltage value

*2. Temperature change ratio for the detection voltage [mV/°C] is calculated using the following equation.

$$\frac{\Delta - V_{DET}}{\Delta Ta} [mV/°C] = -V_{DET(S)} [V] \times \frac{\Delta - V_{DET}}{\Delta Ta \cdot -V_{DET}} [ppm/°C] \div 1000$$

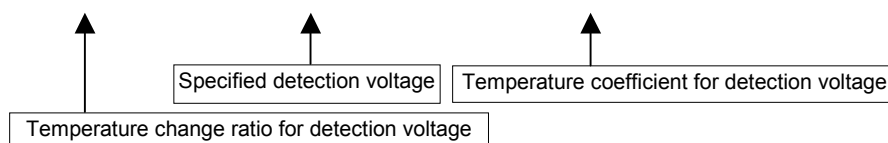

4. CMOS output products (Detection voltage Typ.1.5 V or more)

Table 12

(Unless otherwise specified :Ta=25°C)

Parameter	Symbol	Conditions	Min.	Typ.	Max.	Units	Test circuit	
Detection voltage *1	-V _{DET}	—	-V _{DET(S)} ×0.98	-V _{DET(S)}	-V _{DET(S)} ×1.02	V	1	
Hysteresis width	V _{HYS}	—	-V _{DET} ×0.03	-V _{DET} ×0.05	-V _{DET} ×0.08	V	1	
Current consumption	I _{SS}	V _{DD} =3.5 V	S-80815 to 26	—	0.8	2.4	μA	2
		V _{DD} =4.5 V	S-80827 to 39	—	0.8	2.4		
		V _{DD} =6.0 V	S-80840 to 56	—	0.9	2.7		
		V _{DD} =7.5 V	S-80857 to 60	—	0.9	2.7		
Operating voltage	V _{DD}	S-80815 to 60		0.95	—	10.0	V	1
Output current of output transistor	I _{OUT}	Nch V _{DS} =0.5 V	V _{DD} =1.2 V S-80815 to 60	0.59	1.36	—	mA	3
			V _{DD} =2.4 V S-80827 to 60	2.88	4.98	—		
		Pch V _{DS} =0.5 V	V _{DD} =4.8 V S-80815 to 39	1.43	2.39	—		4
			V _{DD} =6.0 V S-80840 to 56	1.68	2.78	—		
			V _{DD} =8.4 V S-80857 to 60	2.08	3.42	—		
			—	—	—	—		
Response time	t _{PLH}	—		—	—	60	μs	1
Temperature coefficient for detection voltage *2	$\frac{\Delta - V_{DET}}{\Delta Ta \bullet -V_{DET}}$	Ta=-40°C to +85°C		—	±100	±350	ppm/°C	1

*1. -V_{DET} : Actual detection voltage value

-V_{DET(S)} : Specified detection voltage value (The center value of the detection voltage range in **Table 6** and **Table 7**)

*2. Temperature change ratio for the detection voltage [mV/°C] is calculated using the following equation .

$$\frac{\Delta - V_{DET}}{\Delta Ta} [mV/°C] = -V_{DET(S)} [V] \times \frac{\Delta - V_{DET}}{\Delta Ta \bullet -V_{DET}} [ppm/°C] \div 1000$$

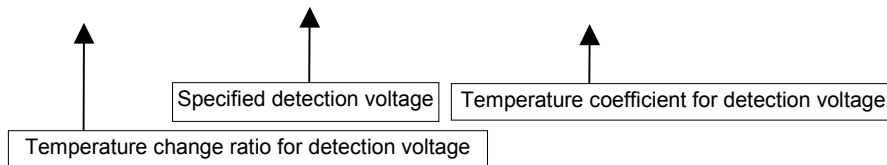

■ Test Circuits

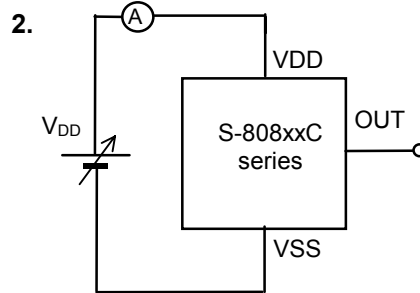
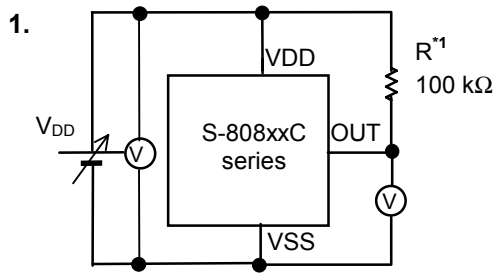

*1. R is unnecessary for CMOS output products.

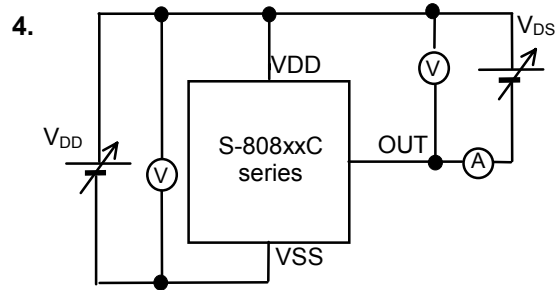
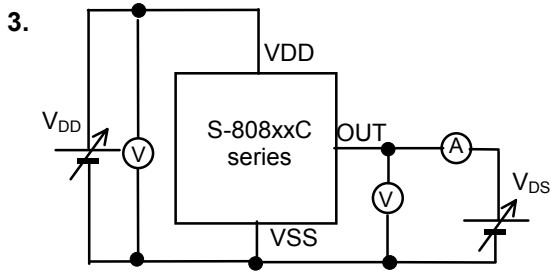

Figure 8

■ **Timing chart**

1. Active low Nch open-drain

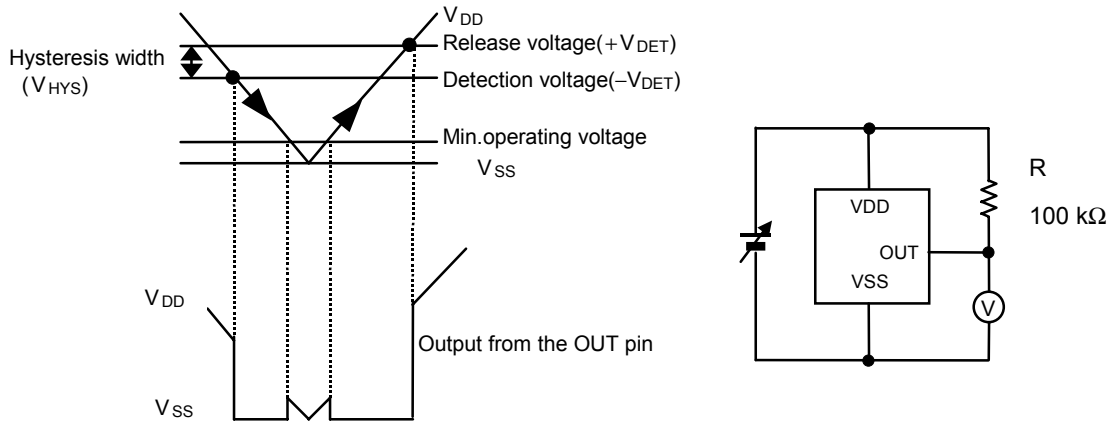

Figure 9

2. Active low CMOS output

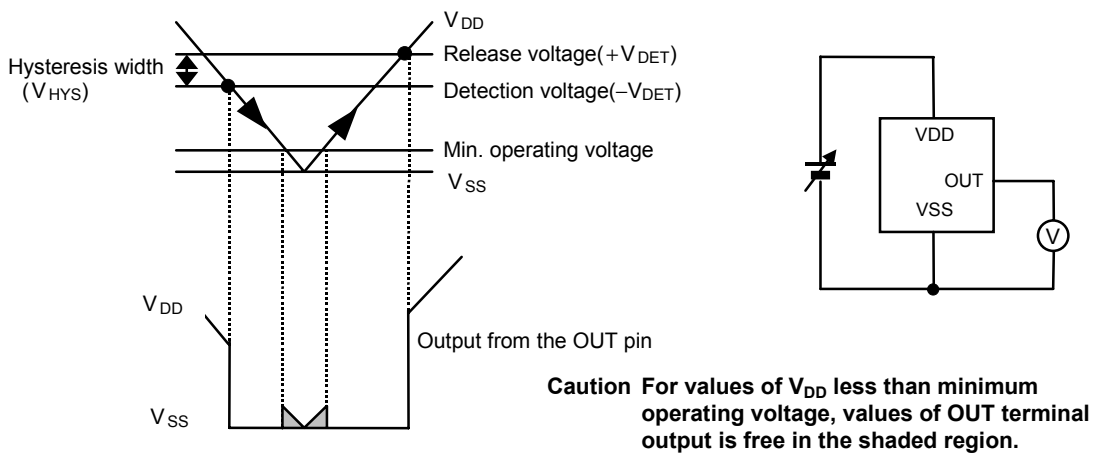

Figure 10

■ **Definition of Terms**

1. Detection voltage ($-V_{DET}$)

The detection voltage ($-V_{DET}$) is a voltage at which the output turns to low. The detection voltage varies slightly among products of the same specification. The variation of detection voltage between the minimum [$(-V_{DET})_{min.}$] and the maximum [$(-V_{DET})_{max.}$] is called the detection voltage range (See **Figure 11**).

Example : For the S-80815CN, the detection voltage lies in the range of $1.470 \leq (-V_{DET}) \leq 1.530$. This means that some S-80815CNs have 1.470 V for $-V_{DET}$ and some have 1.530 V.

2. Release voltage (+V_{DET})

The release voltage (+V_{DET}) is a voltage at which the output turns to high. The release voltage varies slightly among products of the same specification. The variation of release voltages between the minimum [(+V_{DET})min.] and the maximum [(+V_{DET})max.] is called the release voltage range (See **Figure 12**).

The range is calculated from the actual detection voltage -V_{DET} of a product and is expressed by -V_{DET} × 1.03 ≤ +V_{DET} ≤ -V_{DET} × 1.08.

Example : For the S-80815CN, the release voltage lies in the range of 1.514 ≤ (+V_{DET}) ≤ 1.652.
 This means that some S-80815CNs have 1.514 V for +V_{DET} and some have 1.652 V.

Remark Although the detection voltage and release voltage overlap in the range of 1.514 V to 1.530 V, +V_{DET} is always larger than -V_{DET}.

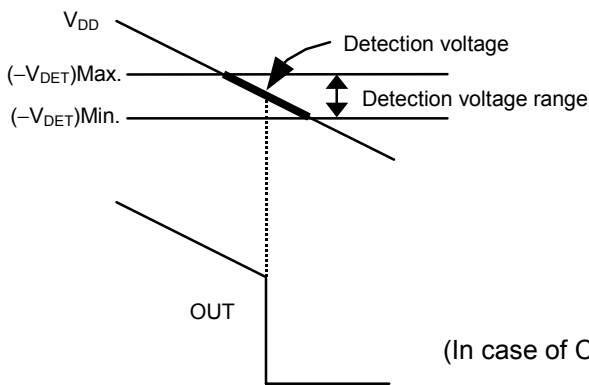

Figure 11 Detection Voltage

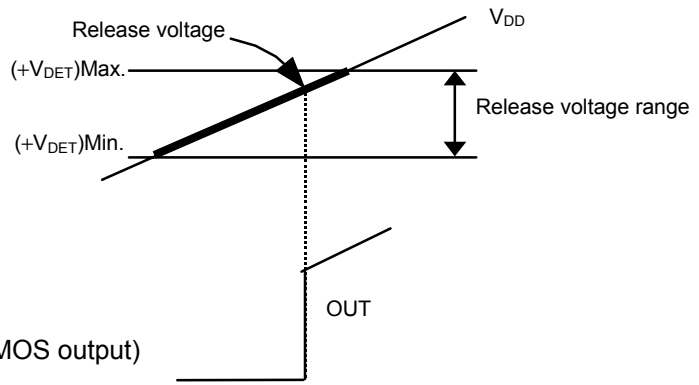

Figure 12 Release Voltage

(In case of CMOS output)

3. Hysteresis width (V_{HYS})

The hysteresis width is the voltage difference between the detection voltage and the release voltage (See **Figure 16**).

The existence of the hysteresis width avoids malfunction caused by noise on input signal.

4. Through-type current

The through-type current in a voltage detector is the current which flows instantaneously at the time of detection and release of a voltage detector. The through-type current is large in CMOS output products, small in Nch open-drain output products.

5. Oscillation

In applications where a resistor is connected to the voltage detector input (**Figure 13**), taking a CMOS active low product for example, the through-type current which is generated when the output goes from low to high (release) causes a voltage drop equal to [through-type current] × [input resistance] across the resistor. When the input voltage drops below the detection voltage -V_{DET} as a result, the output voltage goes to low level. In this state, the through-type current stops and its resultant voltage drop disappears, and the output goes from low to high. A through-type current is again generated, a voltage drop appears, and oscillation is finally induced by repeating the process.

Following is an example for bad implementation: input voltage divider for a CMOS output product.

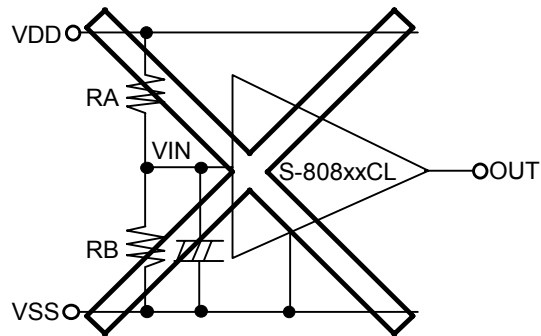
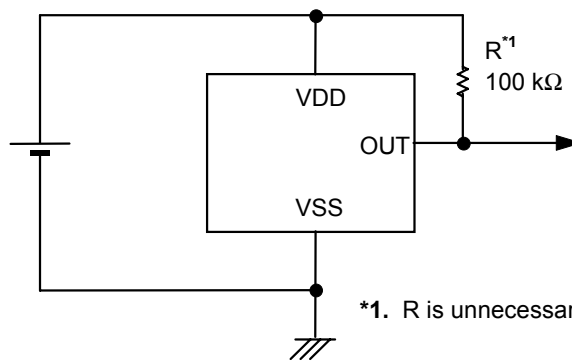

Figure 13 An example for bad implementation

■ **Standard Circuit**



*1. R is unnecessary for CMOS output products.

Figure 14

Caution The above connection diagram and constants do not guarantee correct operation. Perform sufficient evaluation using the actual application to set the constants.

■ Operation Description

1. Basic operation : In case of active low CMOS output

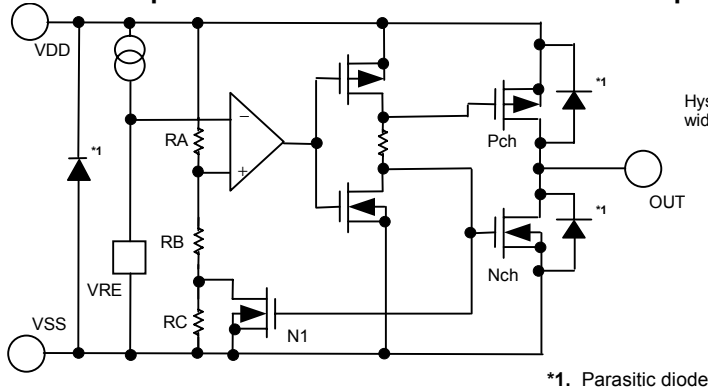

Figure 15 Operation 1

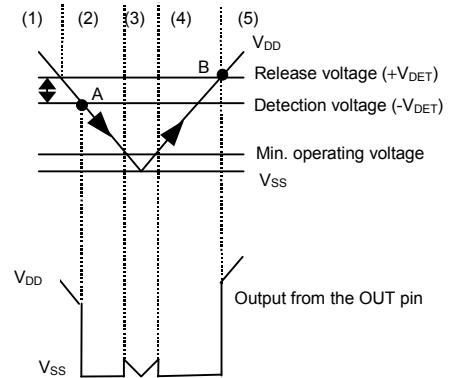

Figure 16 Operation 2

- (1) When the power supply voltage V_{DD} is higher than the release voltage $+V_{DET}$, the Nch transistor is OFF and the Pch transistor is ON to provide V_{DD} (high) at the output. Since the Nch transistor N1 in **Figure 15** is OFF, the comparator input voltage is $(RB+RC)/(RA+RB+RC) \times V_{DD}$.
- (2) When the V_{DD} goes below $+V_{DET}$, the output provides the V_{DD} level, as long as the V_{DD} remains above the detection voltage $-V_{DET}$. When the V_{DD} falls below $-V_{DET}$ (point A in **Figure 16**), the Nch transistor becomes ON, the Pch transistor becomes OFF, and the V_{SS} level appears at the output. At this time the Nch transistor N1 in **Figure 15** becomes ON, the comparator input voltage is changed to $RB/(RA+RB) \times V_{DD}$.
- (3) When the V_{DD} falls below the minimum operating voltage, the output becomes undefined, or goes to the V_{DD} when the output is pulled up to the V_{DD} .
- (4) The V_{SS} level appears when the V_{DD} rises above the minimum operating voltage. The V_{SS} level still appears even when the V_{DD} surpasses $-V_{DET}$, as long as it does not exceed the release voltage $+V_{DET}$.
- (5) When the V_{DD} rises above $+V_{DET}$ (point B in **Figure 16**), the Nch transistor becomes OFF and the Pch transistor becomes ON to provide V_{DD} level at the output.

2. Other characteristics

(1) Temperature dependence of detection voltage

The temperature dependence of the detection voltage is shown by the shaded area in **Figure 17**.

S-80827C:

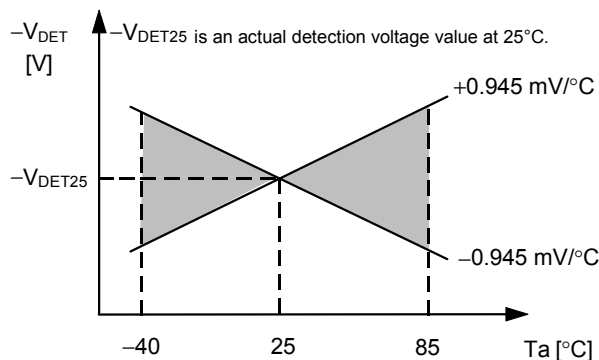

Figure 17 Temperature dependence of Detection Voltage

Seiko Instruments Inc.

(2) Temperature dependence of release voltage

The temperature coefficient $\left(\frac{\Delta + V_{DET}}{\Delta T_a}\right)$ of the release voltage is calculated by the temperature coefficient $\left(\frac{\Delta - V_{DET}}{\Delta T_a}\right)$ of the detection voltage as follows:

$$\frac{\Delta + V_{DET}}{\Delta T_a} = \frac{+V_{DET}}{-V_{DET}} \times \frac{\Delta - V_{DET}}{\Delta T_a}$$

The temperature coefficients for the release voltage and the detection voltage have the same sign consequently.

(3) Temperature characteristics of hysteresis voltage

The temperature dependence of hysteresis voltage is expressed as $\left(\frac{\Delta + V_{DET}}{\Delta T_a} - \frac{\Delta - V_{DET}}{\Delta T_a}\right)$ and is calculated as follows:

$$\frac{\Delta + V_{DET}}{\Delta T_a} - \frac{\Delta - V_{DET}}{\Delta T_a} = \frac{V_{HYS}}{-V_{DET}} \times \frac{\Delta - V_{DET}}{\Delta T_a}$$

■ Electrical Characteristics for customized products

1. S-80824KNUA-D2B-T2 / S-80824KNY-x

Table 13

(Unless otherwise specified: Ta=25 °C)

Parameter	Symbol	Conditions	Min.	Typ.	Max.	Units	Test circuit	
Detection voltage	-V _{DET}	—	2.295	2.400	2.505	V	1	
Release voltage	+V _{DET}	—	4.300	4.400	4.500			
Current consumption	I _{SS}	V _{DD} =6.0 V	—	0.8	2.4	μA	2	
Operating voltage	V _{DD}	—	0.95	—	10.0	V	1	
Output current of output transistor	I _{OUT}	Nch V _{DS} =0.5 V	V _{DD} =0.95 V	0.03	0.24	—	mA	3
			V _{DD} =1.2 V	0.23	0.50	—		
Leakage current of output transistor	I _{LEAK}	Nch V _{DS} =10.0 V, V _{DD} =10.0 V	—	—	0.1	μA	3	
Response time	t _{PLH}	—	—	—	60	μs	1	
Temperature coefficient for detection voltage *1	$\frac{\Delta - V_{DET}}{\Delta T_a \bullet -V_{DET}}$	Ta=-40°C to +85°C	—	±100	±350	ppm/°C	1	

*1. Temperature change ratio for the detection voltage [mV/°C] is calculated using the following equation.

$$\frac{\Delta - V_{DET}}{\Delta T_a} [mV/°C] = -V_{DET} [V] \times \frac{\Delta - V_{DET}}{\Delta T_a \bullet -V_{DET}} [ppm/°C] \div 1000$$

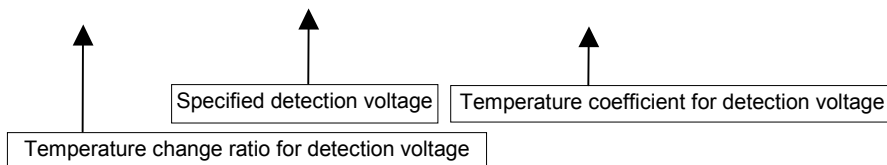

2. S-80844KLUA-D2A-T2 / S-80844KLY-x

Table 14

(Unless otherwise specified: Ta=25 °C)

Parameter	Symbol	Conditions	Min.	Typ.	Max.	Units	Test circuit	
Detection voltage	-V _{DET}	—	4.295	4.450	4.605	V	1	
Release voltage	+V _{DET}	—	—	—	4.700			
Current consumption	I _{SS}	V _{DD} =6.0 V	—	1.0	3.0	μA	2	
Operating voltage	V _{DD}	—	0.95	—	10.0	V	1	
Output current of output transistor	I _{OUT}	Nch V _{DS} =0.5 V	V _{DD} =1.2 V	0.23	0.50	—	mA	3
			V _{DD} =2.4 V	1.60	3.70	—		
		Pch V _{DS} = 0.5 V	V _{DD} =4.8 V	0.36	0.62	—	4	
Response time	t _{PLH}	—	—	—	60	μs	1	
Temperature coefficient for detection voltage *1	$\frac{\Delta - V_{DET}}{\Delta Ta \bullet -V_{DET}}$	Ta=-40°C to +85°C	—	±100	±350	ppm/°C	1	

*1. Temperature change ratio for the detection voltage [mV/°C] is calculated using the following equation.

$$\frac{\Delta - V_{DET}}{\Delta Ta} [mV/°C] = -V_{DET} [V] \times \frac{\Delta - V_{DET}}{\Delta Ta \bullet -V_{DET}} [ppm/°C] \div 1000$$

3. S-80846KNUA-D2C-T2 / S-80846KNY-x

Table 15

(Unless otherwise specified: Ta=25 °C)

Parameter	Symbol	Conditions	Min.	Typ.	Max.	Units	Test circuit	
Detection voltage	-V _{DET}	—	4.500	4.600	4.700	V	1	
Hysteresis width	V _{HYS}	—	—	0.05	0.10			
Current consumption	I _{SS}	V _{DD} =6.0 V	—	0.9	2.7	μA	2	
Operating voltage	V _{DD}	—	0.95	—	10.0	V	1	
Output current of output transistor	I _{OUT}	Nch V _{DS} =0.5 V	V _{DD} =1.2 V	0.59	1.36	—	mA	3
			V _{DD} =2.4 V	2.88	4.98	—		
Leakage current of output transistor	I _{LEAK}	Nch V _{DD} =10.0 V, V _{DS} =10.0 V	—	—	0.1	μA	3	
Response time	t _{PLH}	—	—	—	60	μs	1	
Temperature coefficient for detection voltage *1	$\frac{\Delta - V_{DET}}{\Delta Ta \bullet -V_{DET}}$	Ta=-40°C to +85°C	—	±100	±350	ppm/°C	1	

*1. Temperature change ratio for the detection voltage [mV/°C] is calculated using the following equation.

$$\frac{\Delta - V_{DET}}{\Delta Ta} [mV/°C] = -V_{DET} [V] \times \frac{\Delta - V_{DET}}{\Delta Ta \bullet -V_{DET}} [ppm/°C] \div 1000$$

■ Typical Characteristics

(1) Detection voltage (V_{DET}) - Temperature (T_a)

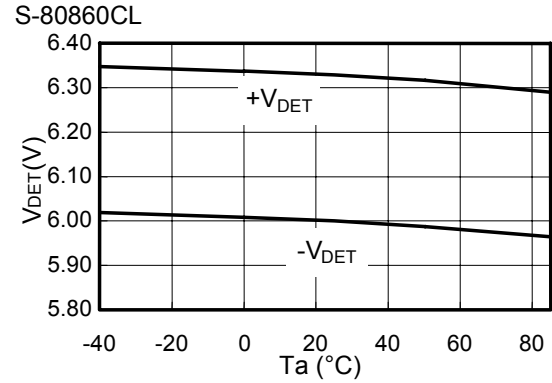
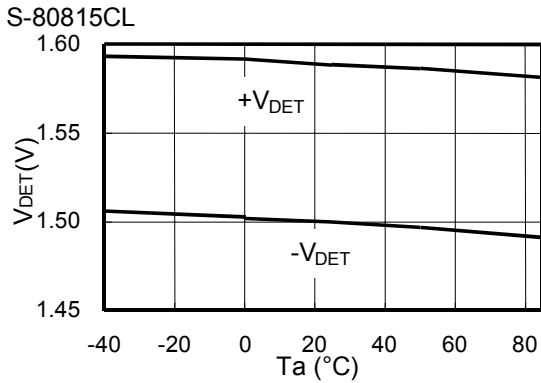
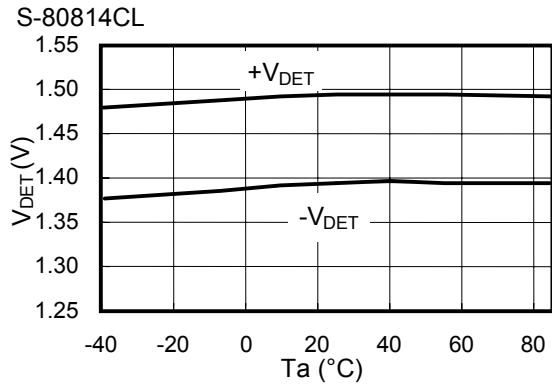
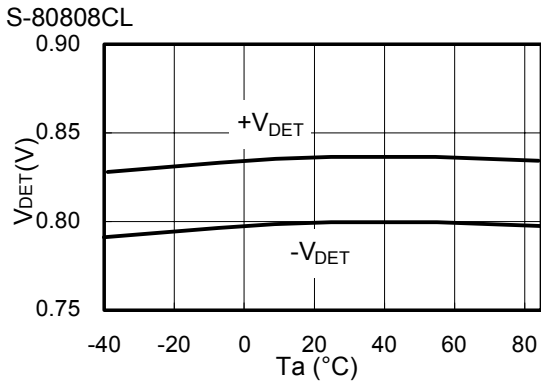

(2) Hysteresis voltage width (V_{HYS}) - Temperature (T_a)

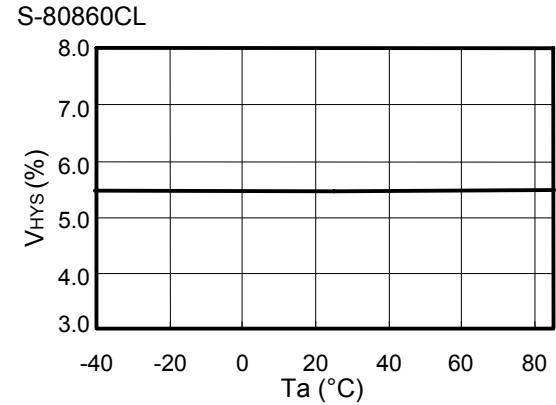
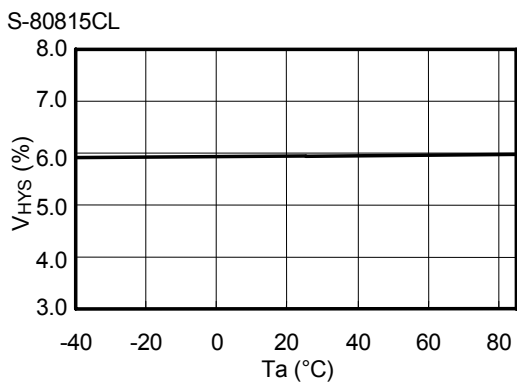
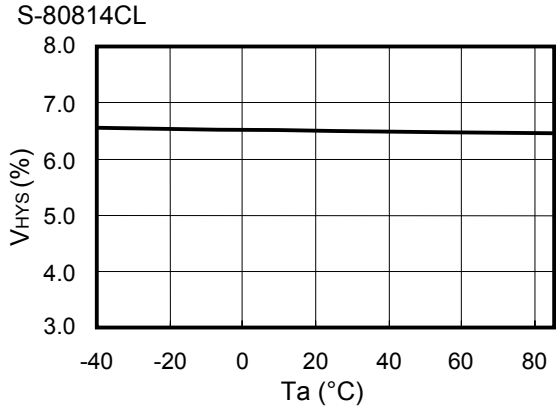
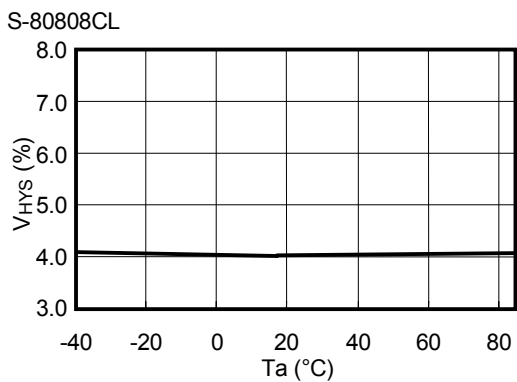

(3) Current consumption (I_{SS}) - Input voltage (V_{DD})

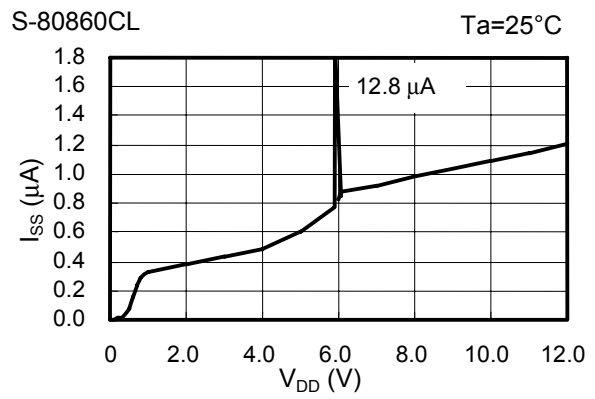
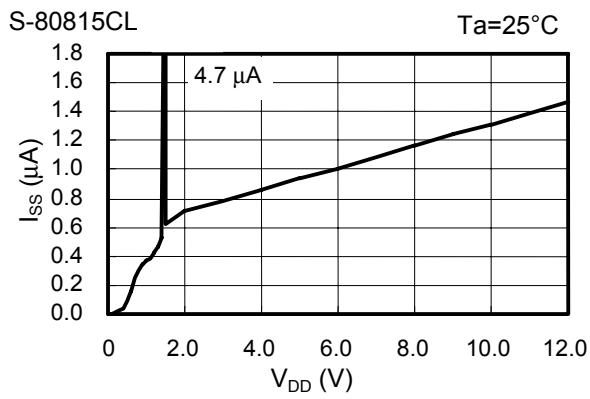
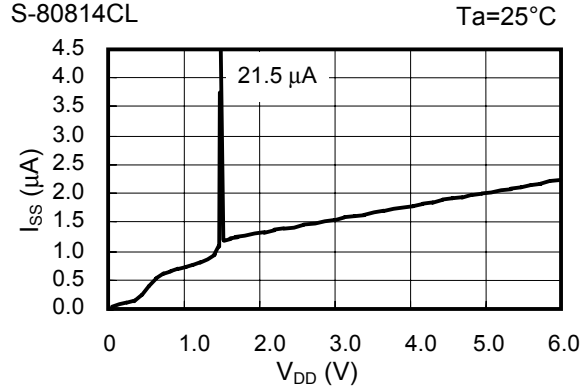
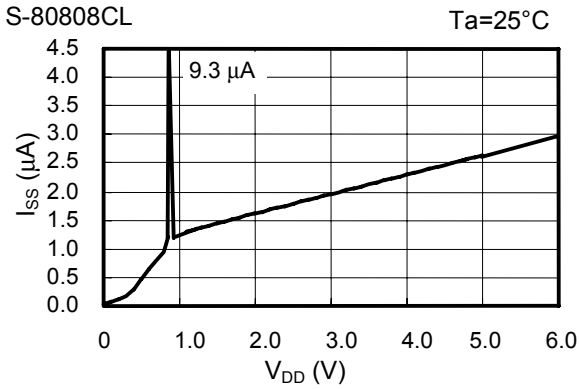

(4) Current consumption (I_{SS}) - Temperature (T_a)

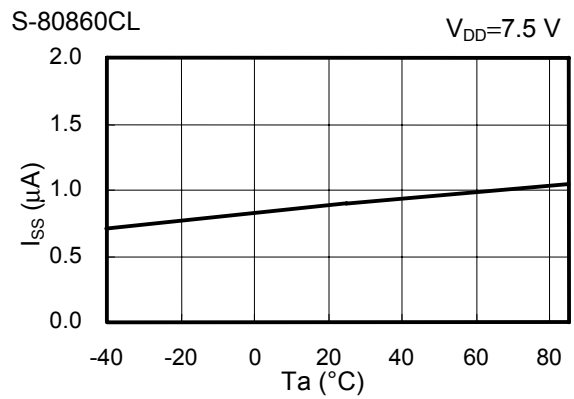
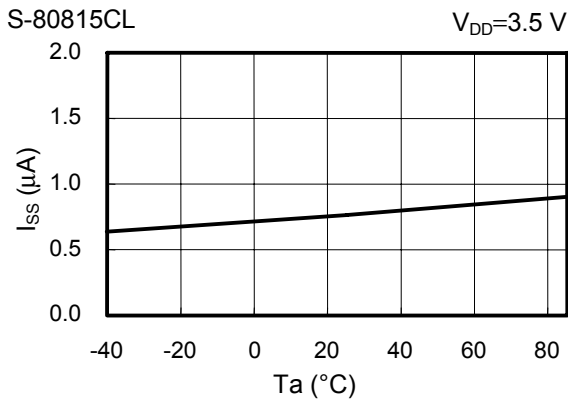
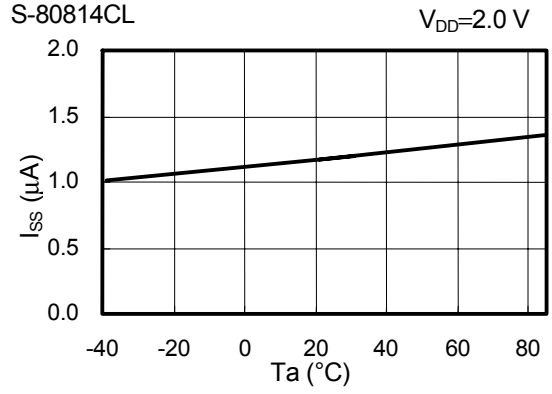
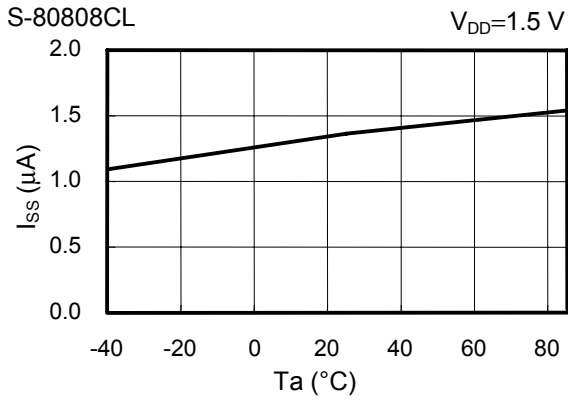

(5) Nch transistor output current (I_{OUT}) - V_{DS}

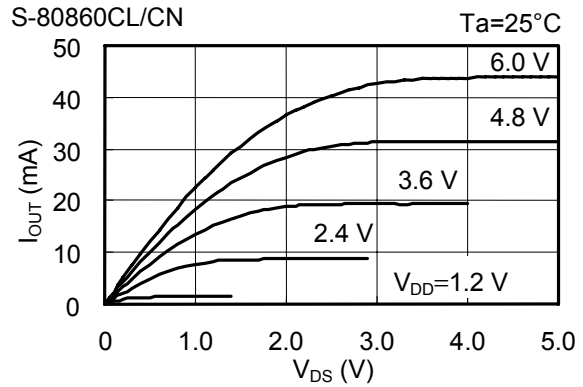
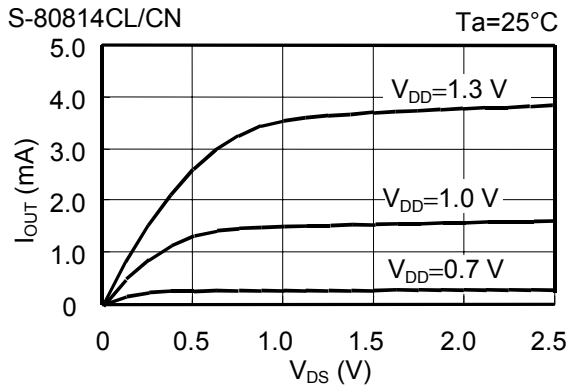

(6) Pch transistor output current (I_{OUT}) - V_{DS}

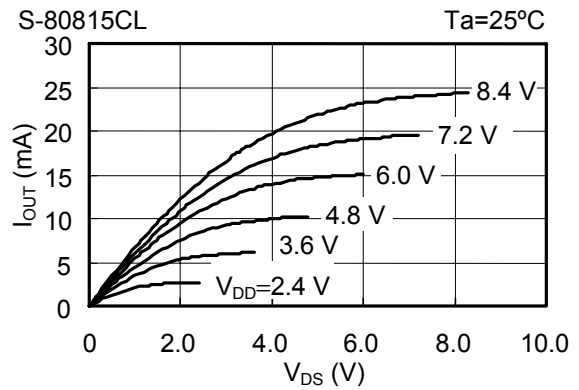
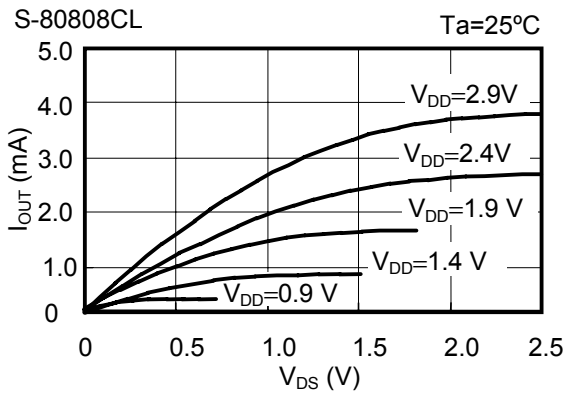

(7) Nch transistor output current (I_{OUT})

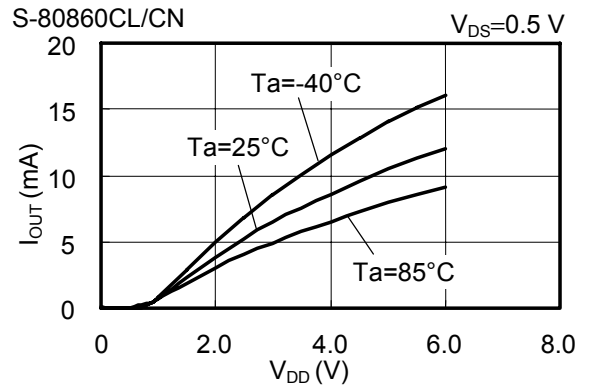
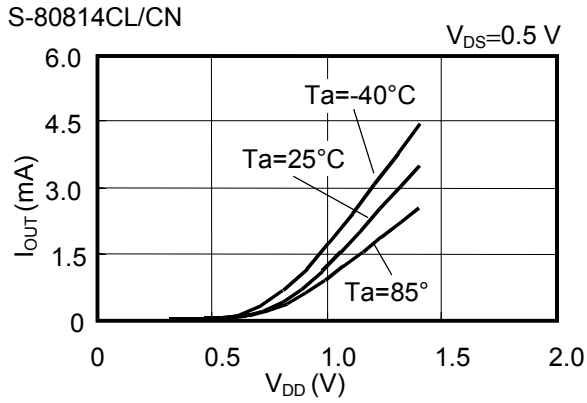

(8) Pch transistor output current (I_{OUT})

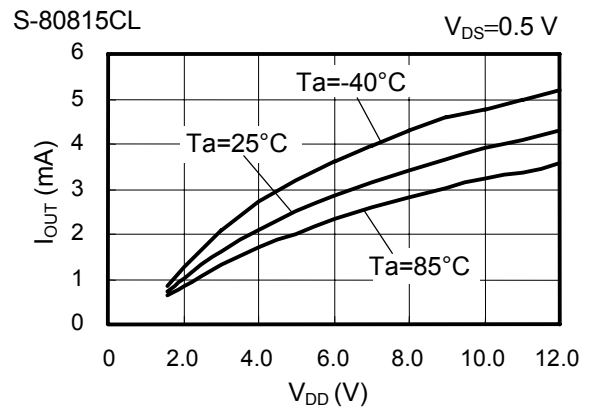
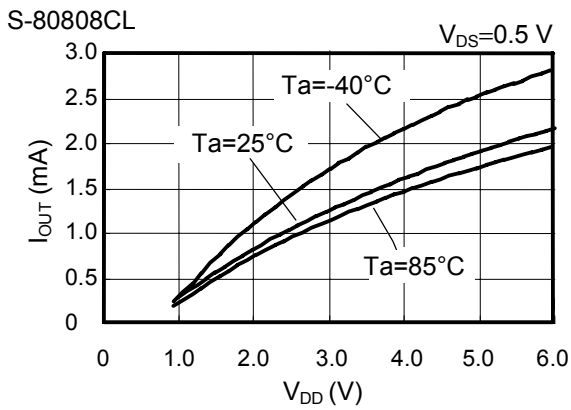

(9) Minimum operating voltage - Input voltage (V_{DD})

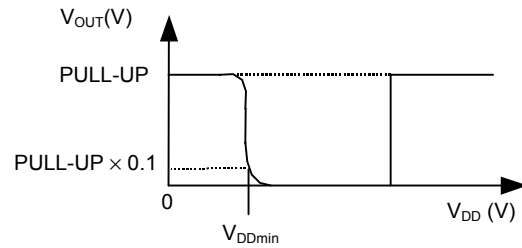
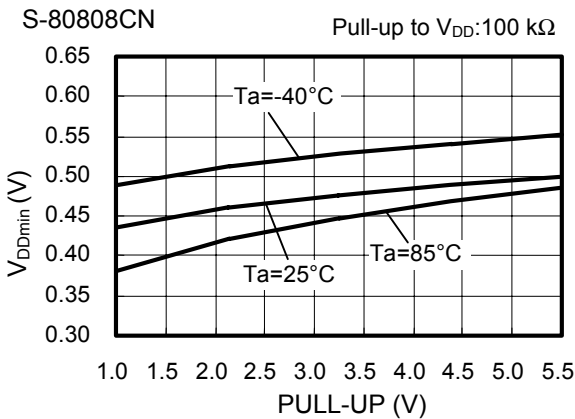
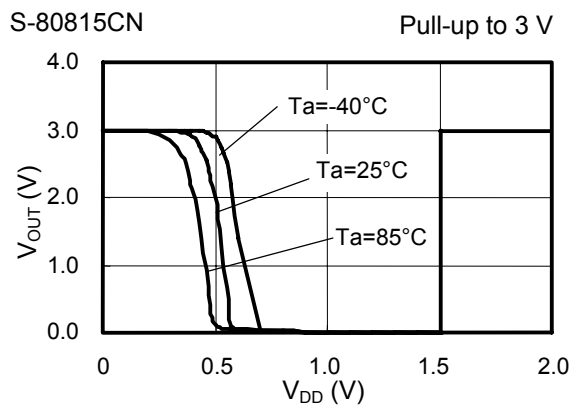
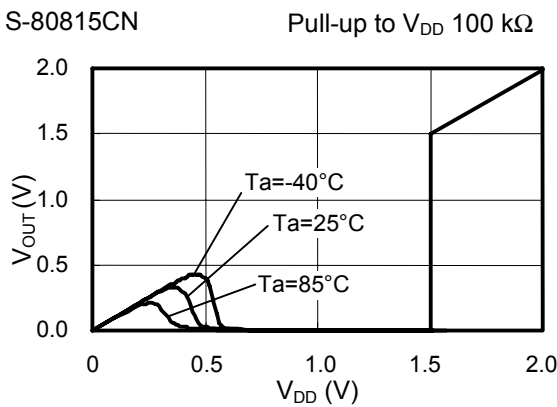
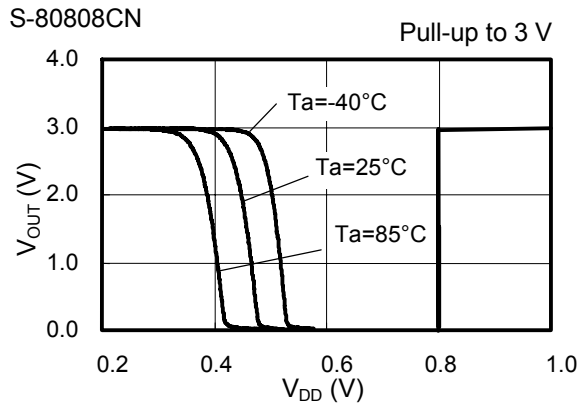
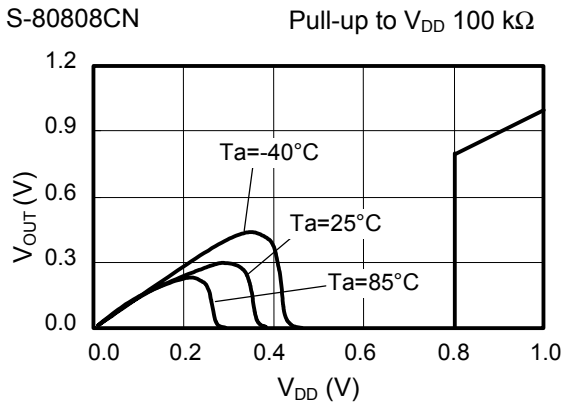

Remark V_{DDmin} is defined by the V_{DD} voltage at which V_{OUT} goes below 10% of PULL-UP voltage when the V_{DD} increase from 0 V.

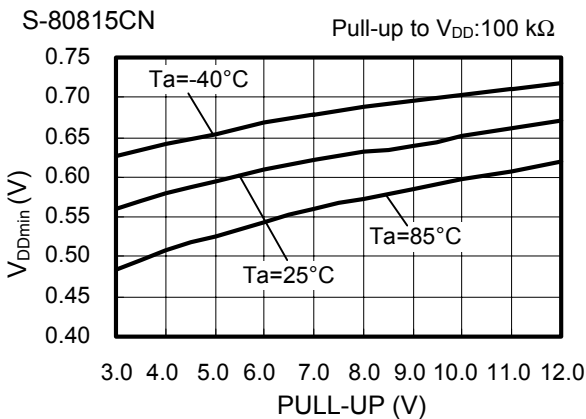

(10) Dynamic response - Load capacitor (C_{OUT})

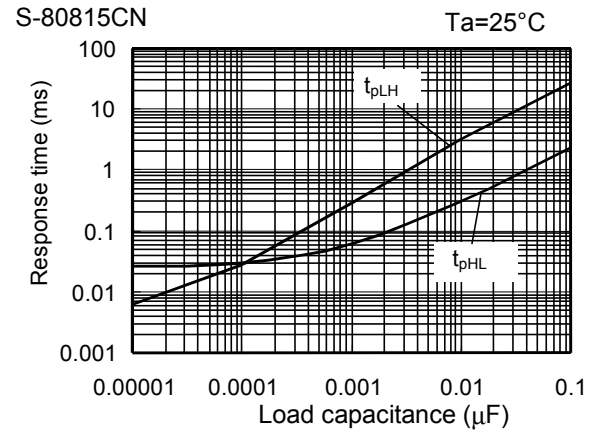
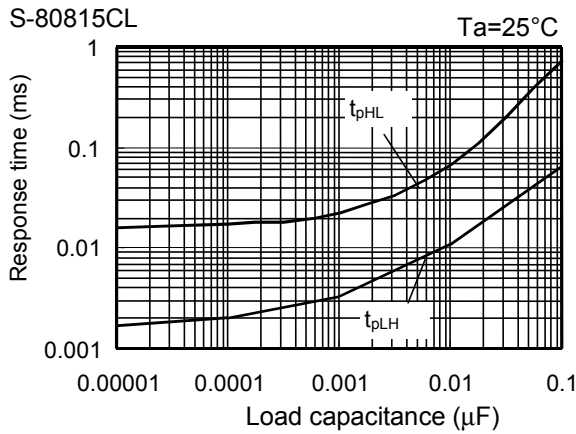
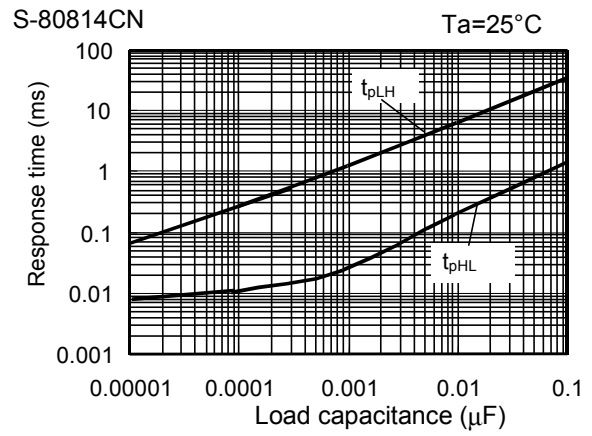
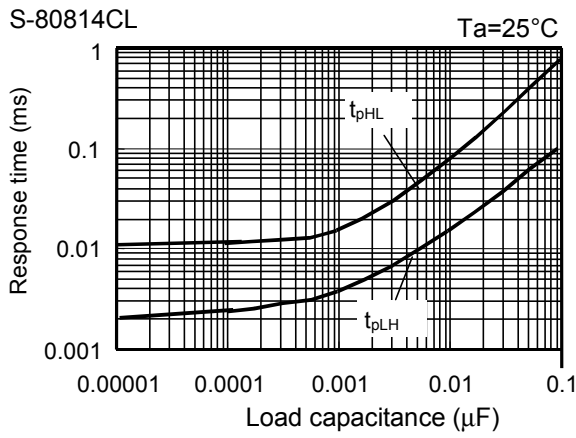
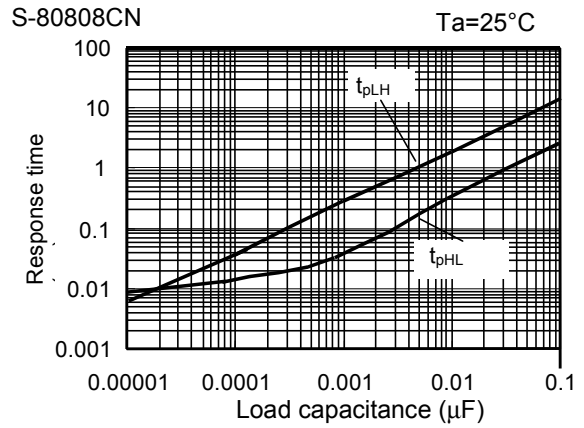
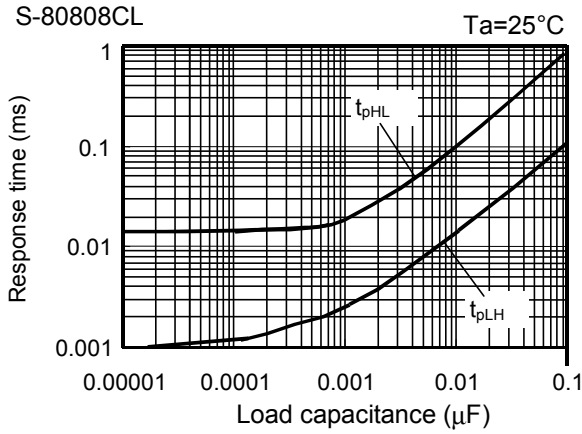

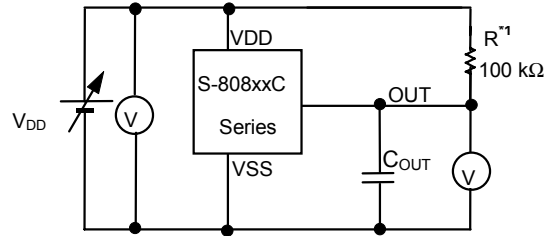
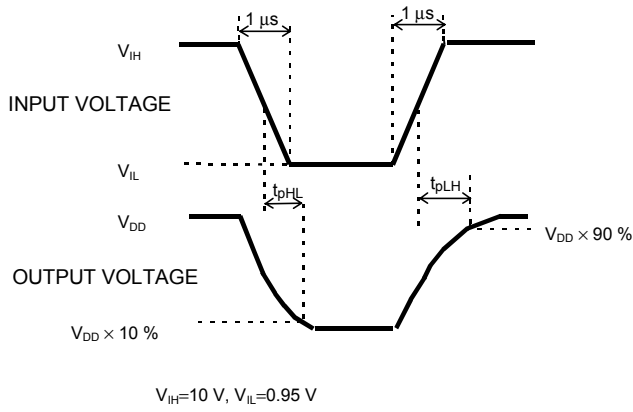
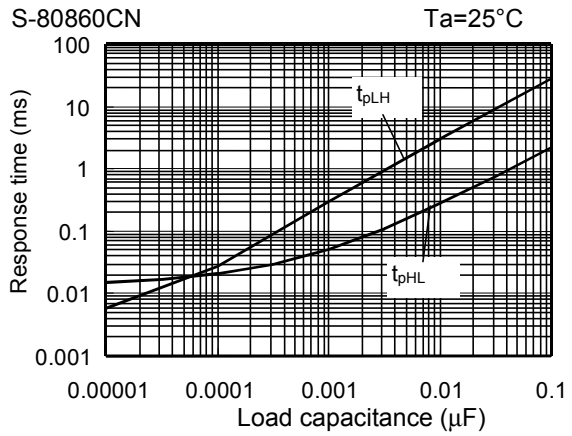
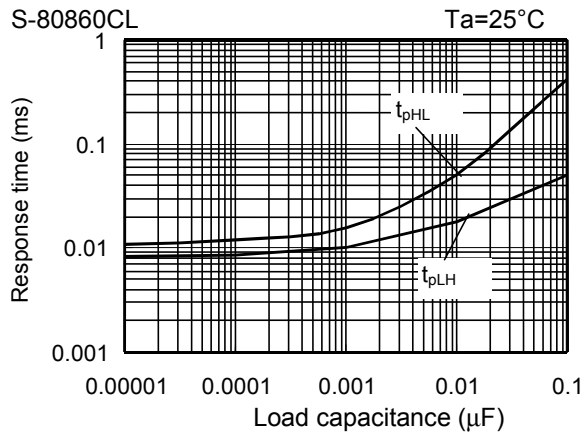

*1. R is not necessary for CMOS output products.

Figure 18 Measurement Condition for Response Time

Figure 19 Measurement Circuit for Response Time

■ **Application Circuit Examples**

1. **Microcomputer reset circuits**

If the power supply voltage to a microcomputer falls below the specified level, an unspecified operation may be performed or the contents of the memory register may be lost. When power supply voltage returns to normal, the microcomputer needs to be initialized before normal operations can be done.

Reset circuits protect microcomputers in the event of current being momentarily switched off or lowered.

Reset circuits shown in **Figures 20** and **21** can be easily constructed with the help of the S-808xxC series, since the detector has low operating voltage, a high-precision detection voltage and hysteresis.

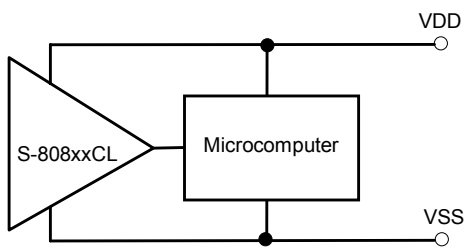
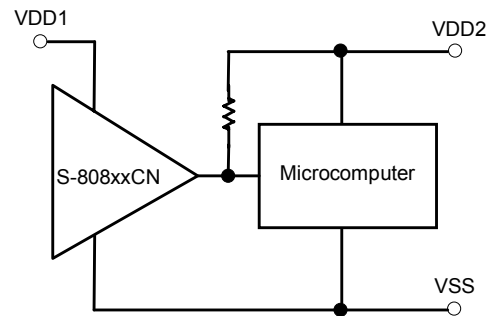

Figure 20 Reset Circuit (S-808xxCL)



(Nch open-drain products only)

Figure 21 Reset Circuit (S-808xxCN)

2. Power-on reset circuit

A power-on reset circuit can be constructed using Nch open-drain product of S-808xxC Series.

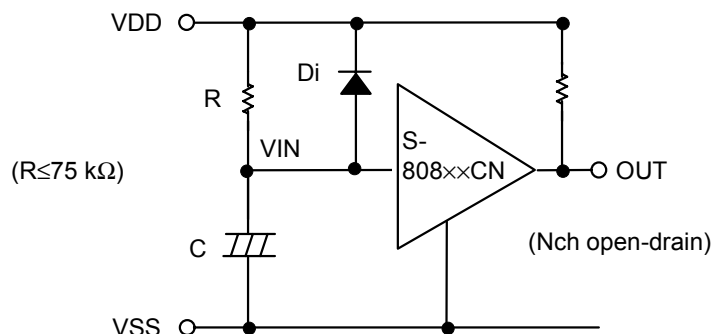

Figure 22

- Remark 1.** Resistor R should be 75 kΩ or less to avoid oscillation.
- 2.** Diode Di instantaneously discharges the charge stored in the capacitor C at the power falling, Di can be removed when the delay of the falling time is not important.

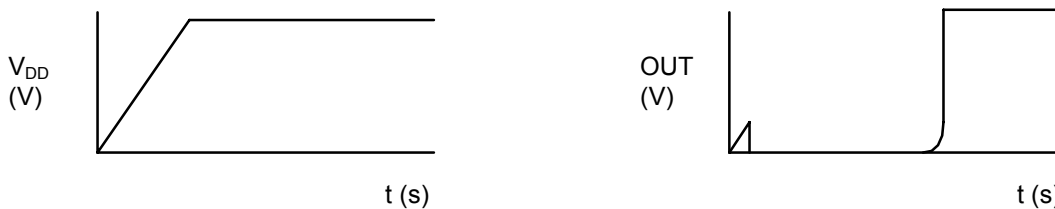

Figure 23

Remark When the power rises sharply as shown in the **Figure 24** left, the output may go to the high level for an instant in the undefined region where the output voltage is undefined since the power voltage is less than the minimum operation voltage.

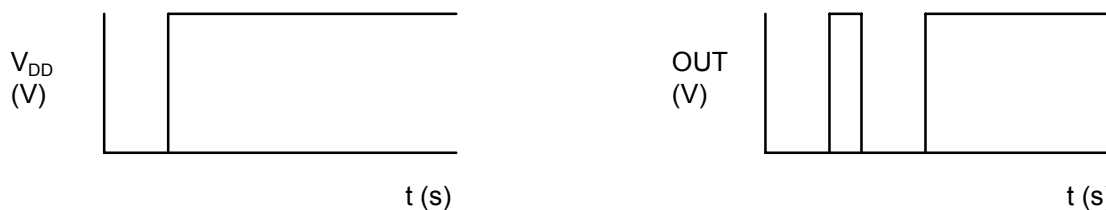
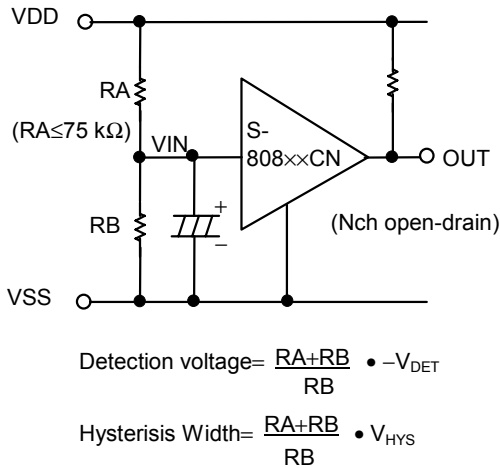

Figure 24

3. Change of detection voltage

In Nch open-drain output products of the S-808xxC series, detection voltage can be changed using resistance dividers or diodes as shown in **Figures 25** and **26**. In **Figure 25** hysteresis width also changes.



- Remark 1.** If RA and RB are large, the hysteresis width may be larger than the value given by the above equation due to the through-type current (which flows slightly in an Nch open-drain product).
- 2.** RA should be 75 kΩ or less to avoid oscillation.

Figure 25

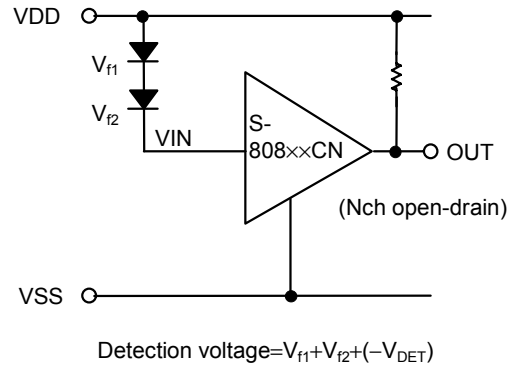
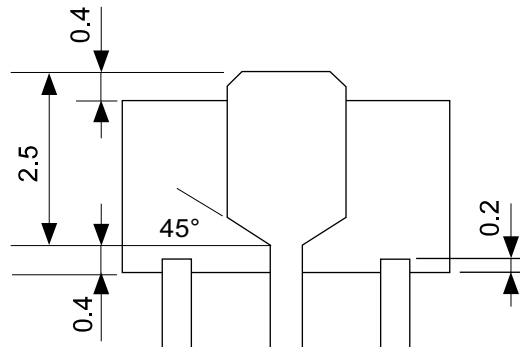
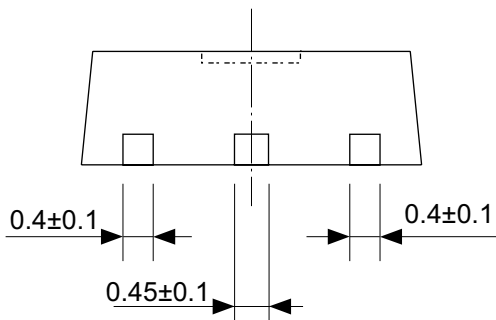
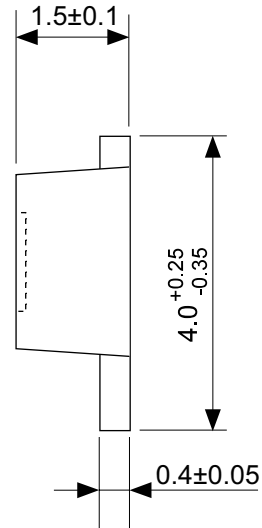
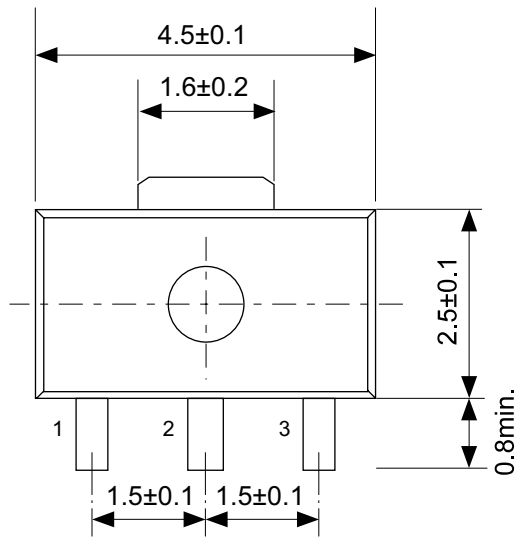

Figure 26

Caution The above connection diagram and constants do not guarantee correct operation. Perform sufficient evaluation using the actual application to set the constants.

■ Precautions

- In CMOS output products of the S-808xxC series, the short-circuit current flows at the detection and the release. If the input impedance is high, oscillation may occur due to the voltage drop by the short-circuit current during releasing.
- Do not apply an electrostatic discharge to this IC that exceeds the performance ratings of the built-in electrostatic protection circuit.
- When designing for mass production using an application circuit described herein, parts deviation and temperature characteristics should be taken into consideration.
Seiko Instruments Inc. shall not bear any responsibility for the patents on the circuits described herein.



No. UP003-A-P-SD-1.1

TITLE	SOT893-A-PKG Dimensions
No.	UP003-A-P-SD-1.1
SCALE	
UNIT	mm
Seiko Instruments Inc.	

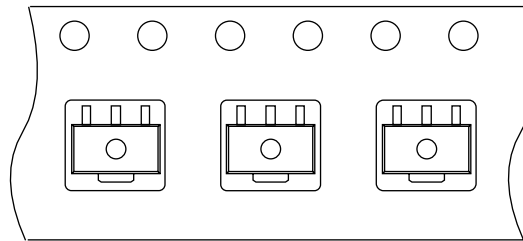
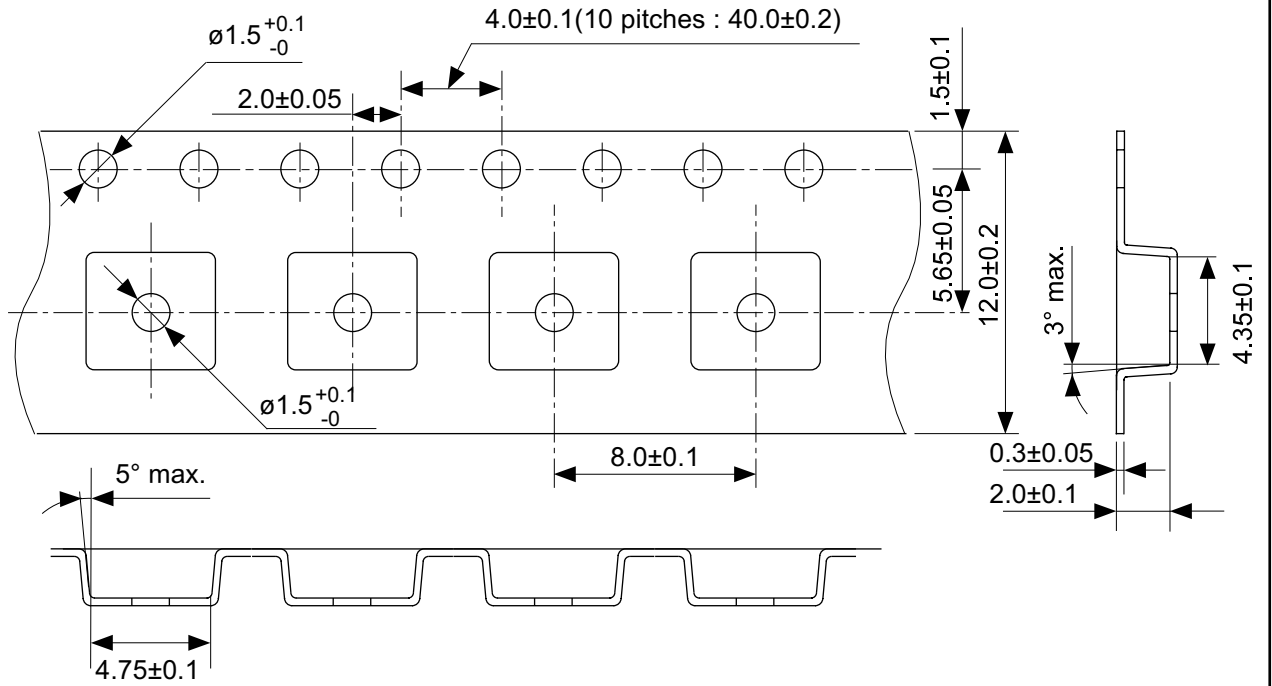

→
Feed direction

No. UP003-A-C-SD-1.1

TITLE	SOT893-A-Carrier Tape
No.	UP003-A-C-SD-1.1
SCALE	
UNIT	mm

Seiko Instruments Inc.

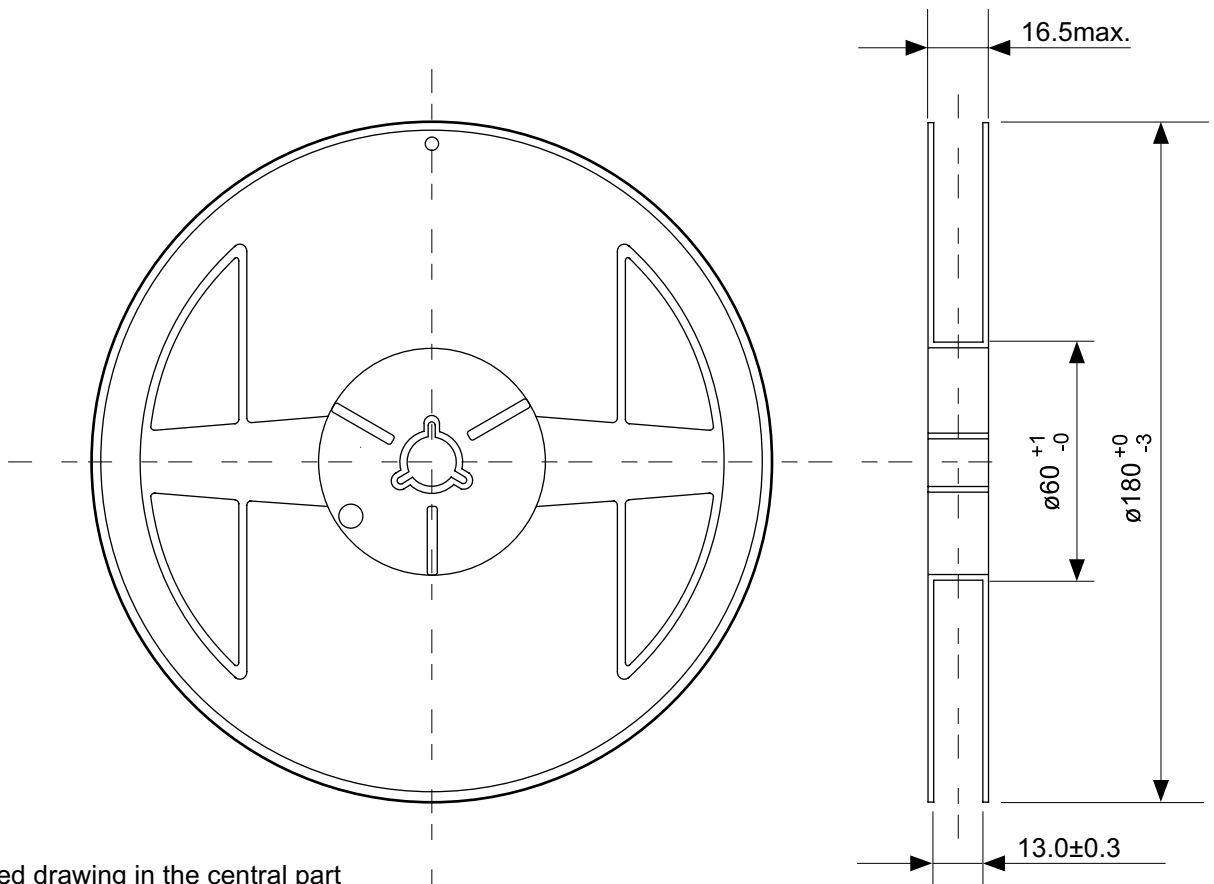

Enlarged drawing in the central part

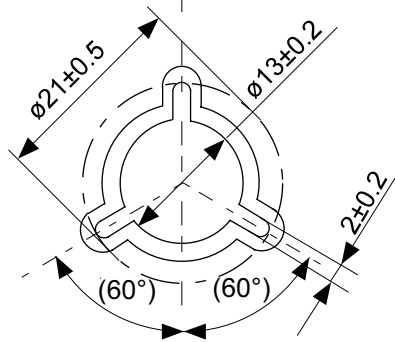

No. UP003-A-R-SD-1.1

TITLE	SOT893-A-Reel		
No.	UP003-A-R-SD-1.1		
SCALE		QTY.	1,000
UNIT	mm		
Seiko Instruments Inc.			

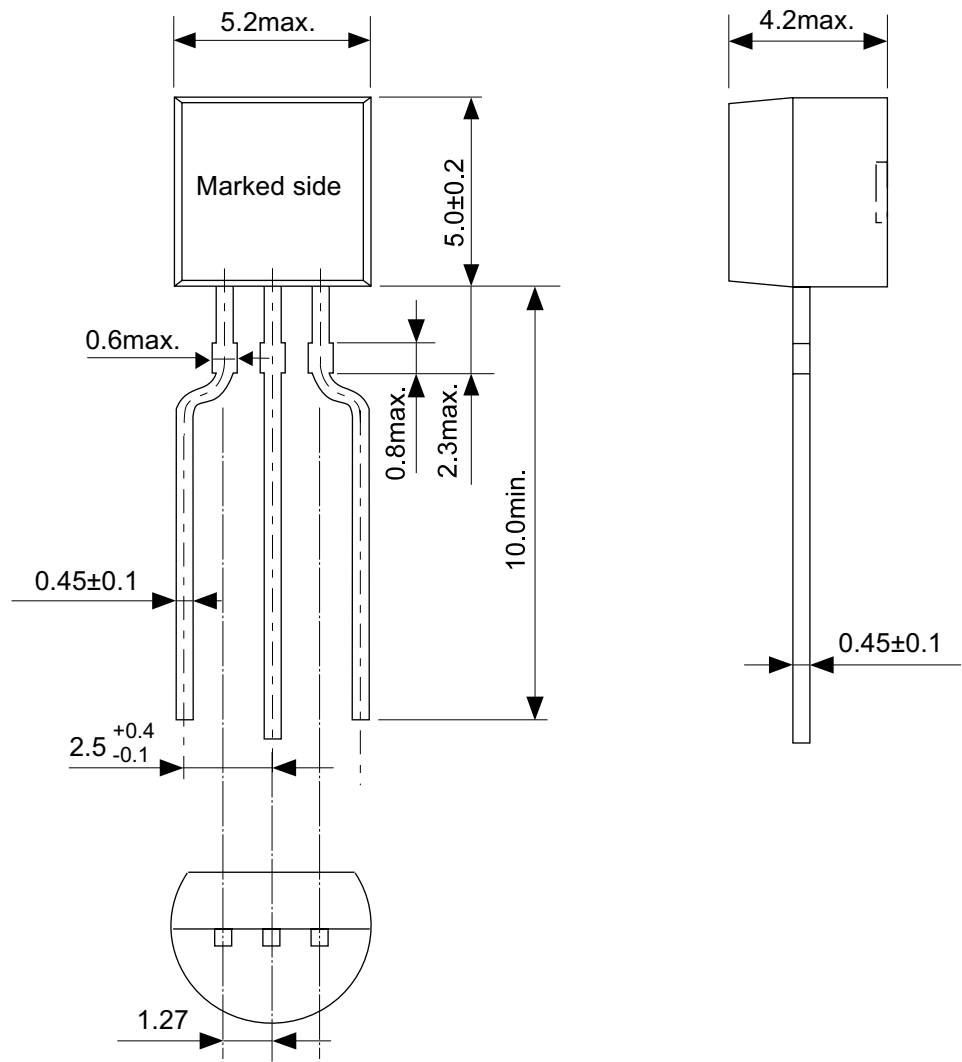

No. YF003-A-P-SD-1.1

TITLE	TO92-A-PKG Dimensions
No.	YF003-A-P-SD-1.1
SCALE	
UNIT	mm
Seiko Instruments Inc.	

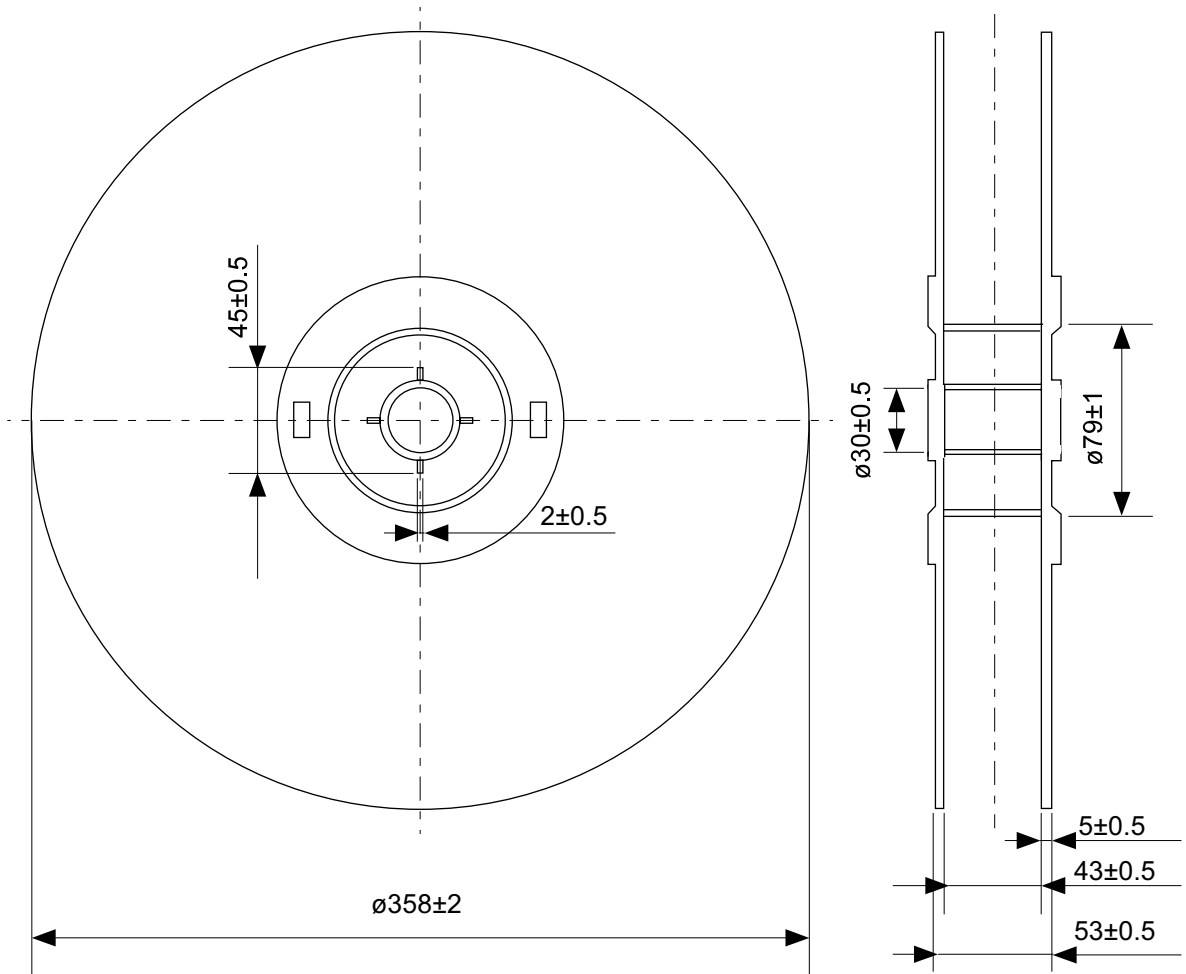

No. YF003-A-R-SD-2.1

TITLE	TO92-A-Reel		
No.	YF003-A-R-SD-2.1		
SCALE		QTY.	2,000
UNIT	mm		
Seiko Instruments Inc.			

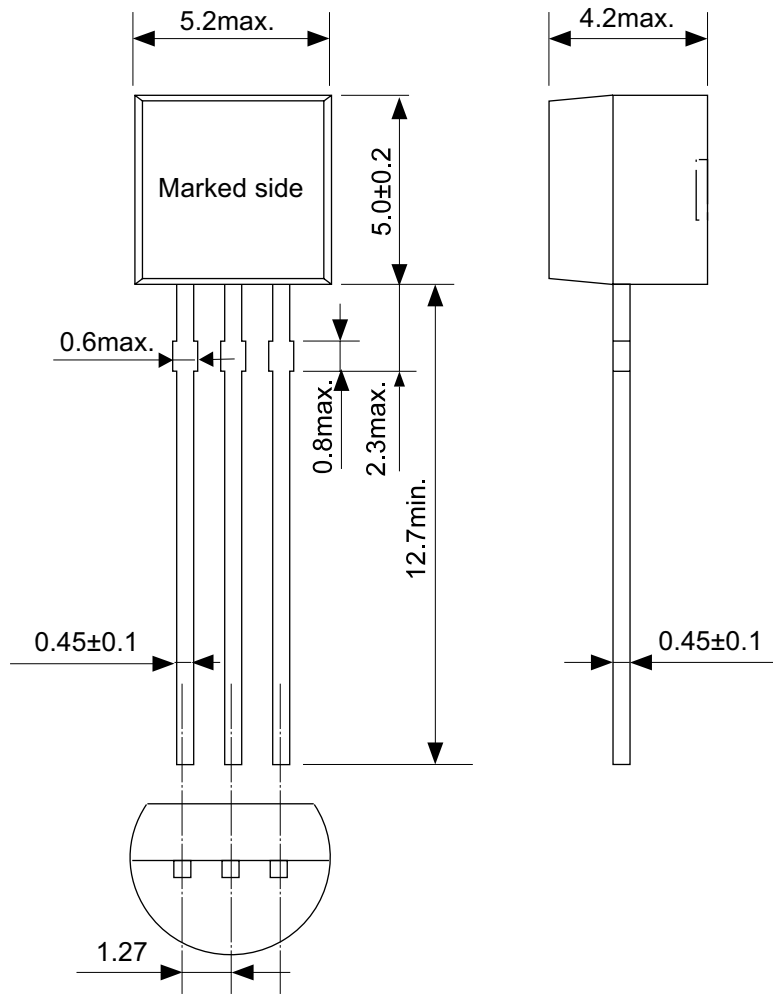

No. YS003-B-P-SD-1.1

TITLE	TO92-B-PKG Dimensions
No.	YS003-B-P-SD-1.1
SCALE	
UNIT	mm

Seiko Instruments Inc.

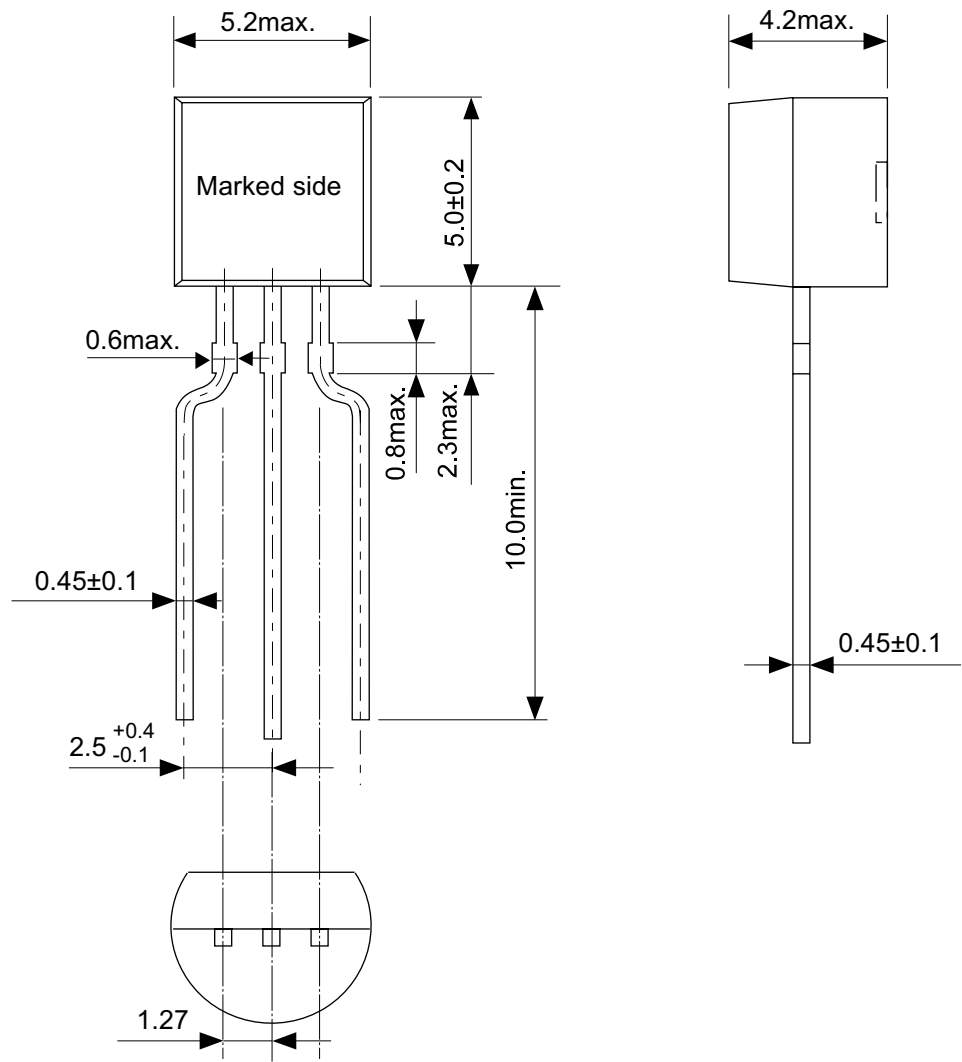

No. YF003-A-P-SD-1.1

TITLE	TO92-A-PKG Dimensions
No.	YF003-A-P-SD-1.1
SCALE	
UNIT	mm
Seiko Instruments Inc.	

Spacer

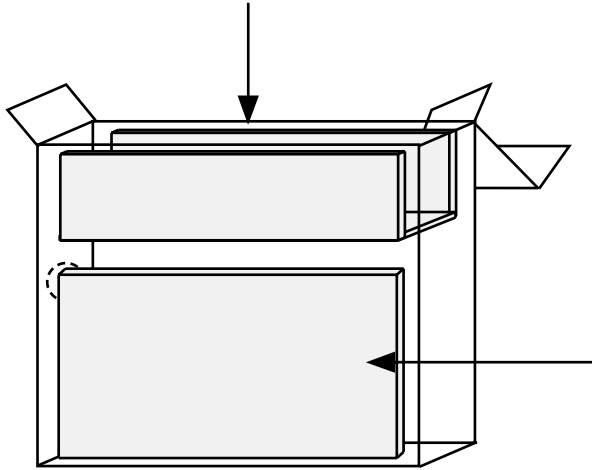
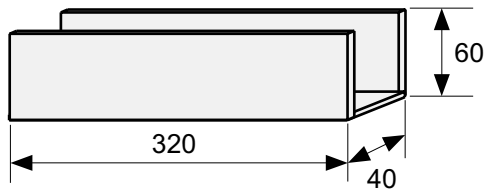

Side spacer placed in front side

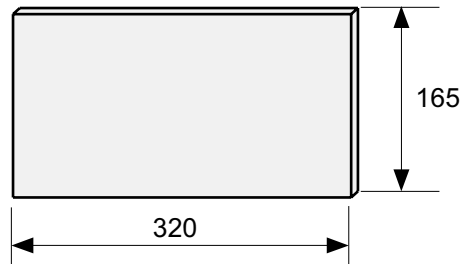

Space more than 4 strokes

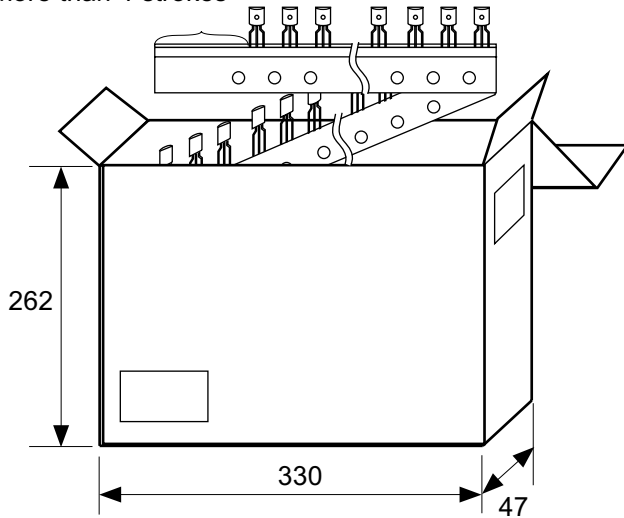

No. YZ003-C-Z-SD-2.1

TITLE	TO92-C-Ammo Packing		
No.	YZ003-C-Z-SD-2.1		
SCALE		QTY.	2,500
UNIT	mm		
Seiko Instruments Inc.			

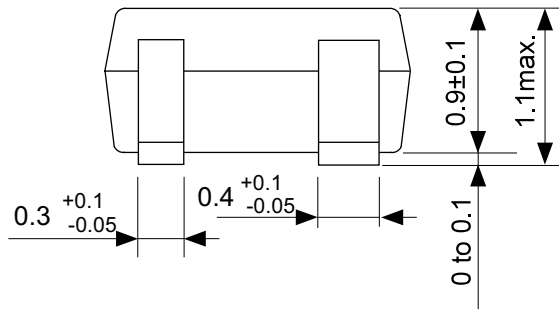
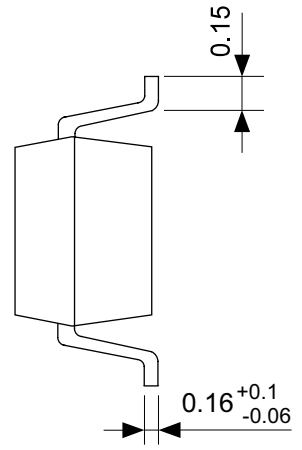
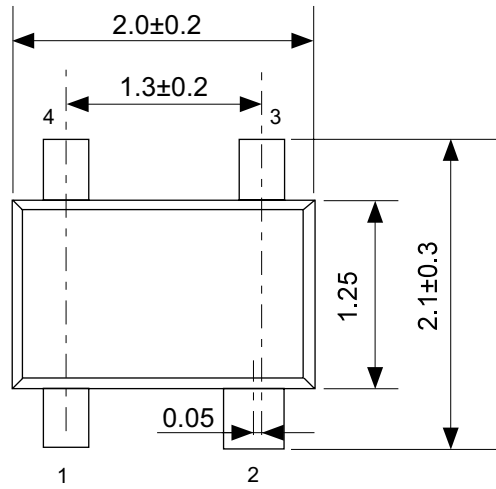

No. NP004-A-P-SD-1.1

TITLE	SC82AB-A-PKG Dimensions
No.	NP004-A-P-SD-1.1
SCALE	
UNIT	mm
Seiko Instruments Inc.	

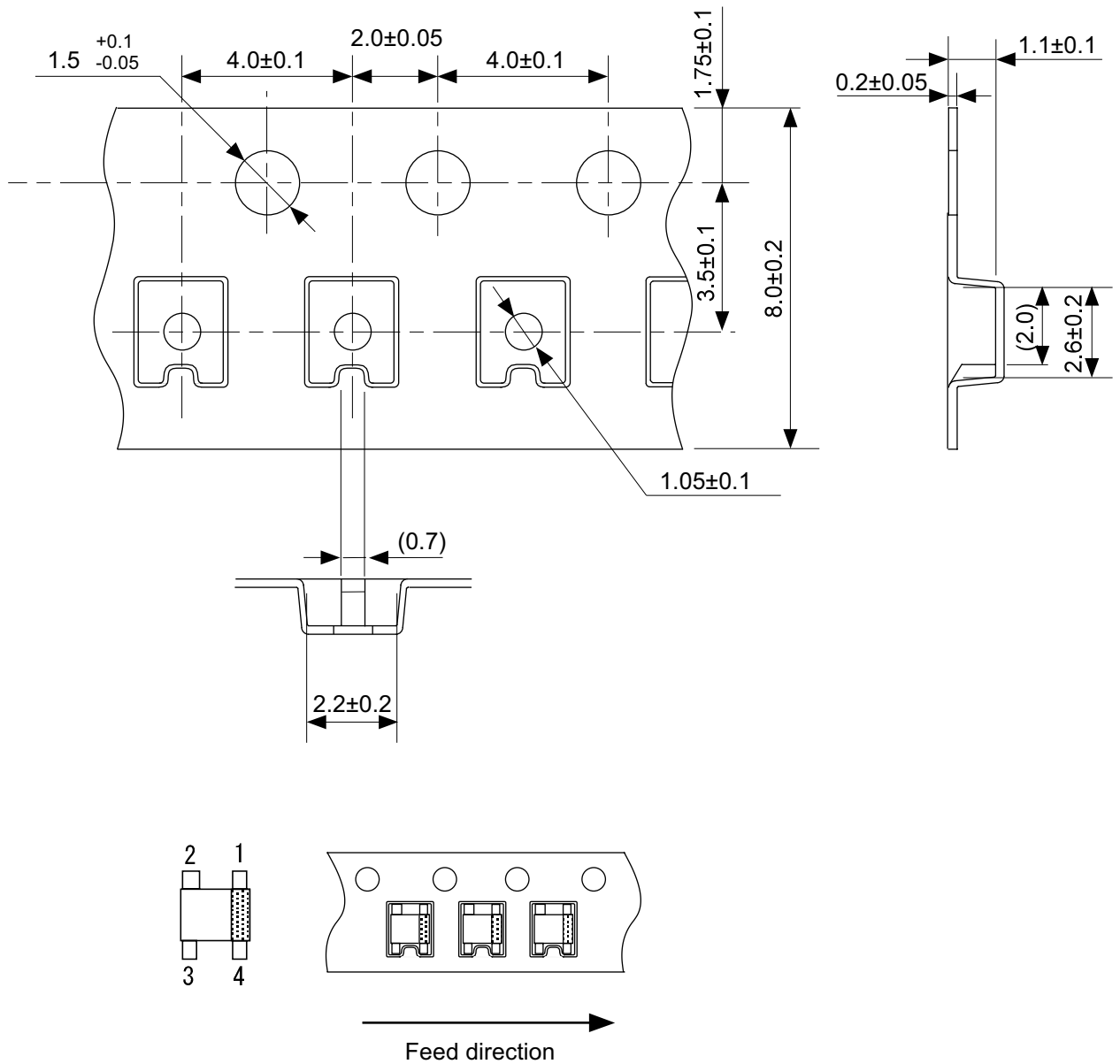

No. NP004-A-C-SD-2.1

TITLE	SC82AB-A-Carrier Tape
No.	NP004-A-C-SD-2.1
SCALE	
UNIT	mm
Seiko Instruments Inc.	

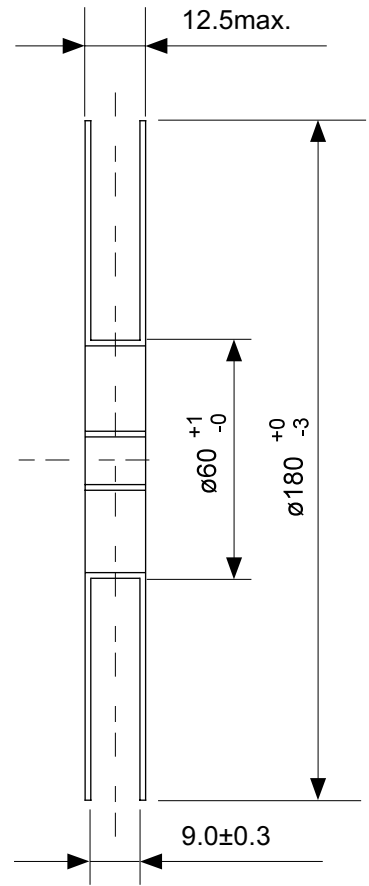
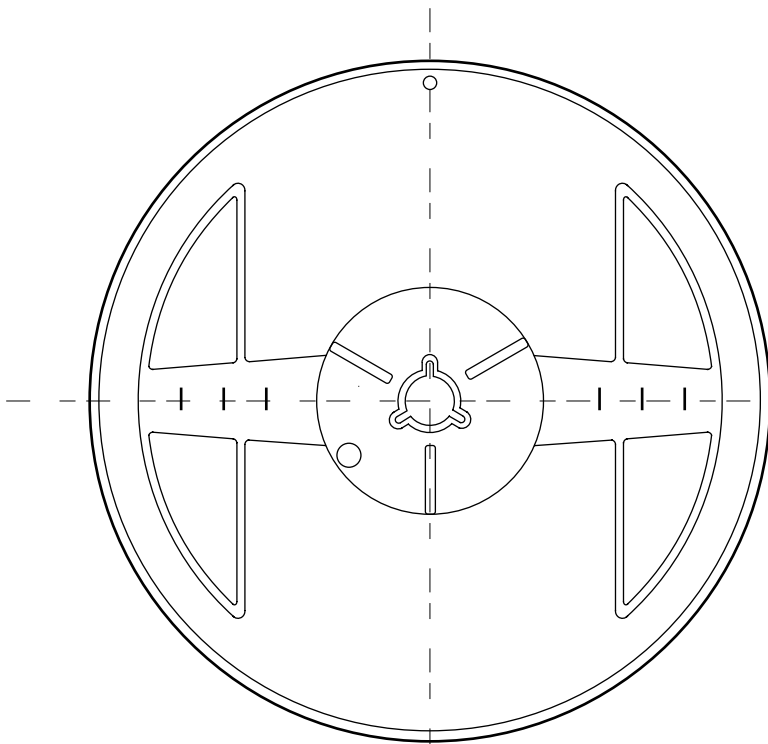

Enlarged drawing in the central part

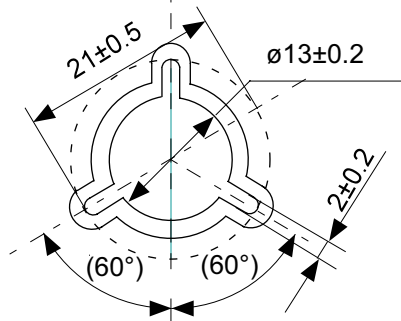

No. NP004-A-R-SD-1.1

TITLE	SC82AB-A-Reel		
No.	NP004-A-R-SD-1.1		
SCALE		QTY.	3,000
UNIT	mm		
Seiko Instruments Inc.			

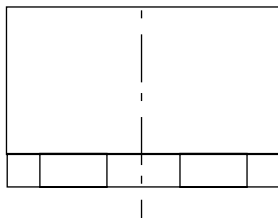
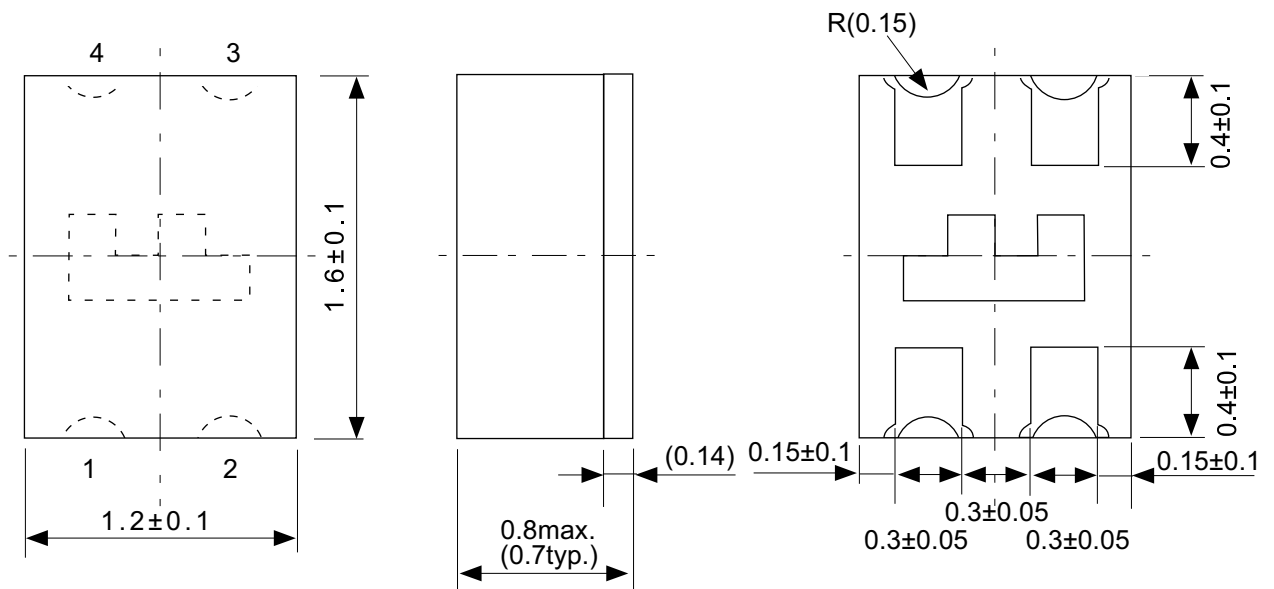

Electrode (Magnified)

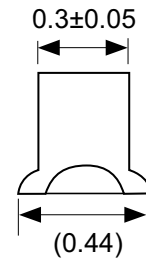

Direction identification mark

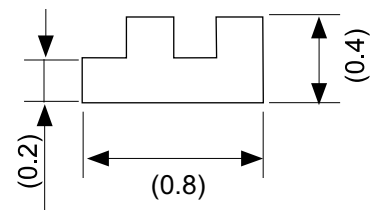

No. BB004-A-P-SD-1.1

TITLE	SNB4B-A-PKG Dimensions
No.	BB004-A-P-SD-1.1
SCALE	
UNIT	mm
Seiko Instruments Inc.	

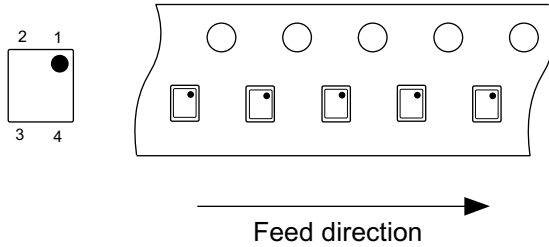
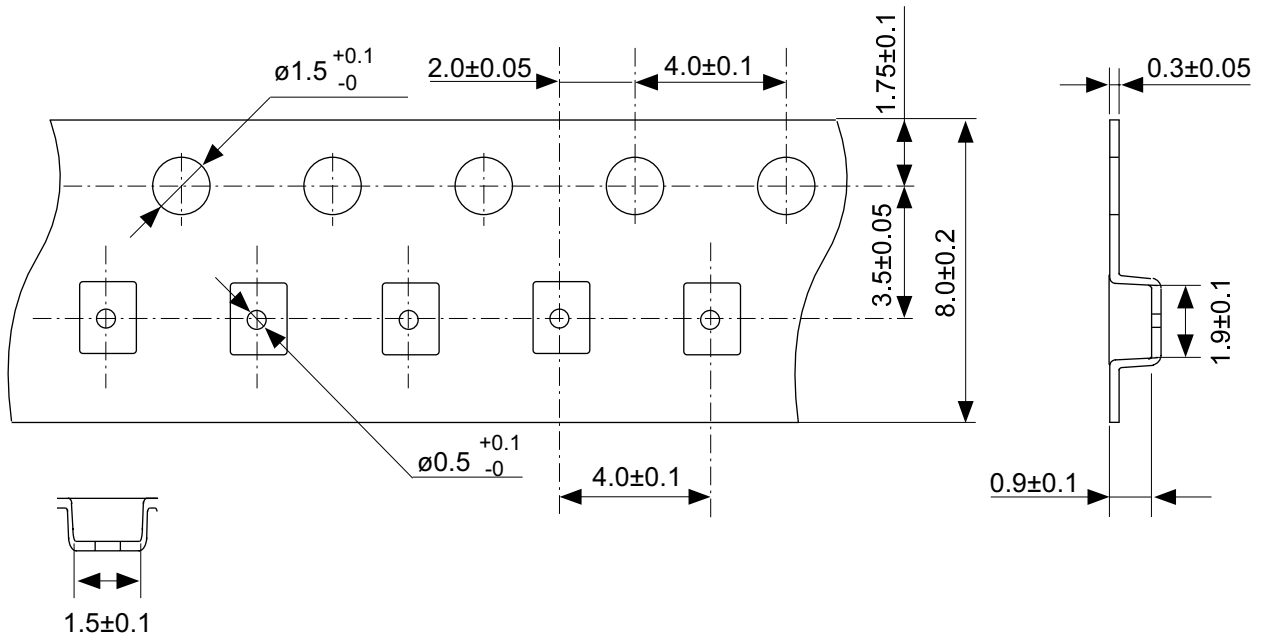

No. BB004-A-C-SD-1.1

TITLE	SNB4B-A-Carrier Tape
No.	BB004-A-C-SD-1.1
SCALE	
UNIT	mm
Seiko Instruments Inc.	

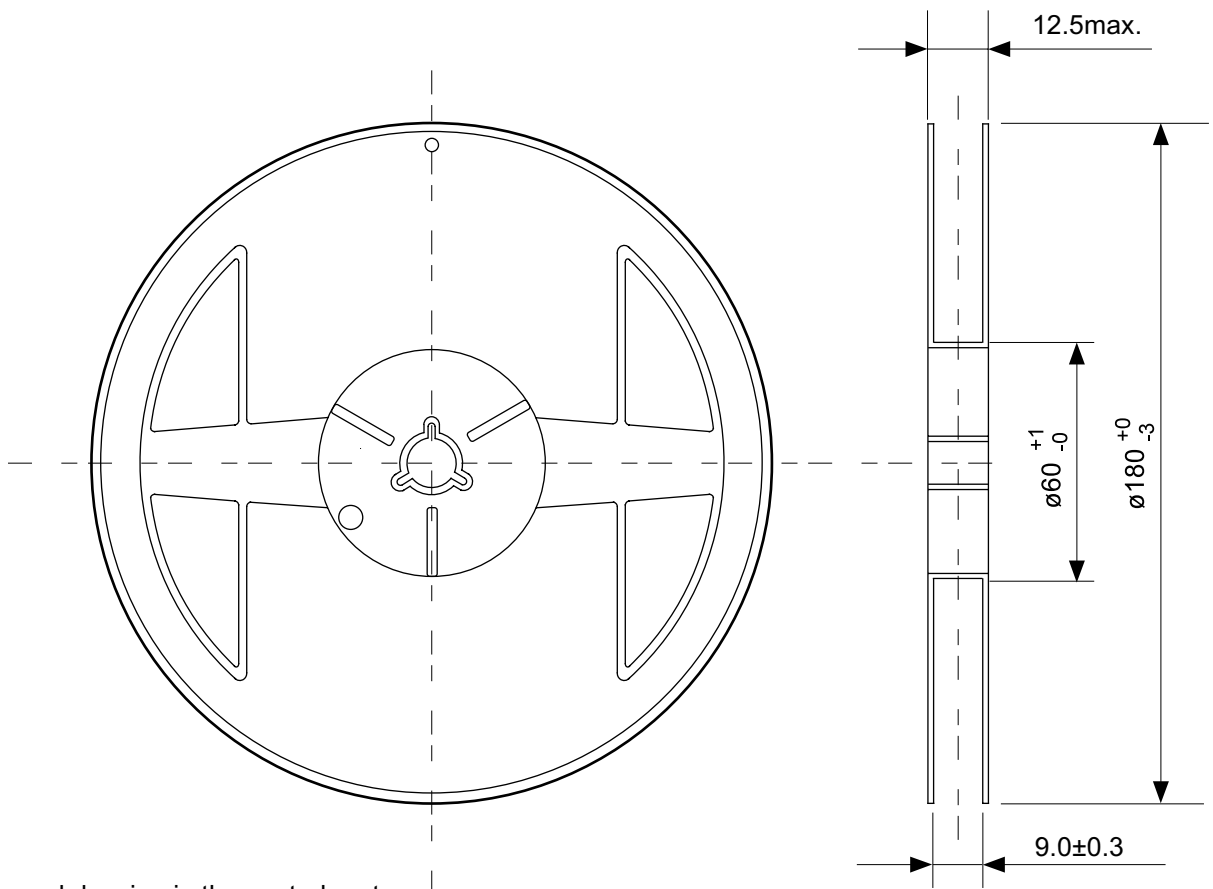

Enlarged drawing in the central part

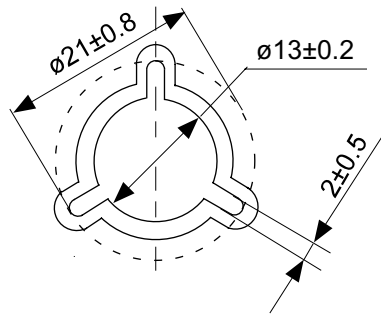

No. BB004-A-R-SD-1.1

TITLE	SNB4B-A-Reel		
No.	BB004-A-R-SD-1.1		
SCALE		QTY.	5.000
UNIT	mm		
Seiko Instruments Inc.			

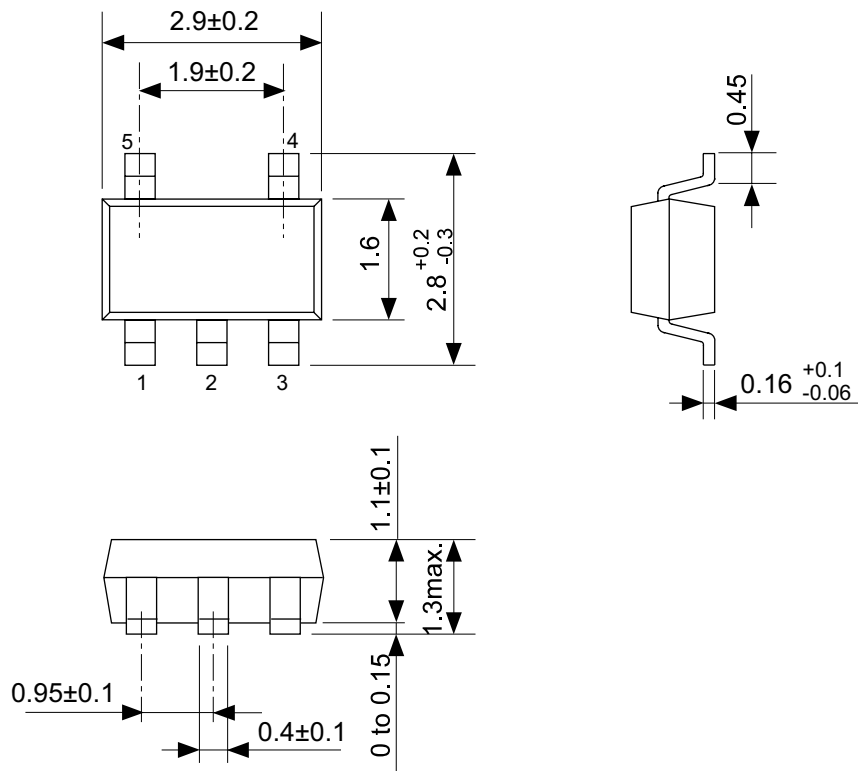

No. MP005-A-P-SD-1.2

TITLE	SOT235-A-PKG Dimensions
No.	MP005-A-P-SD-1.2
SCALE	
UNIT	mm
Seiko Instruments Inc.	

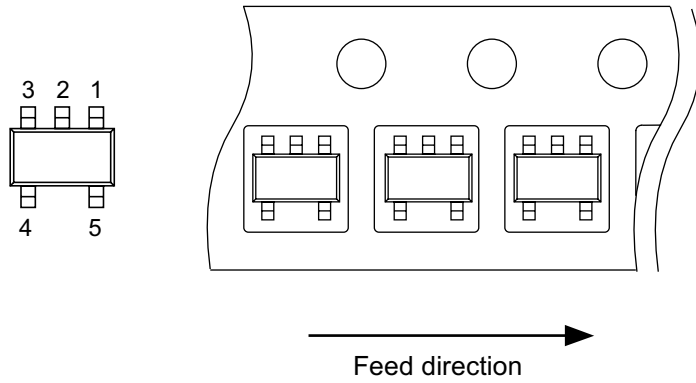
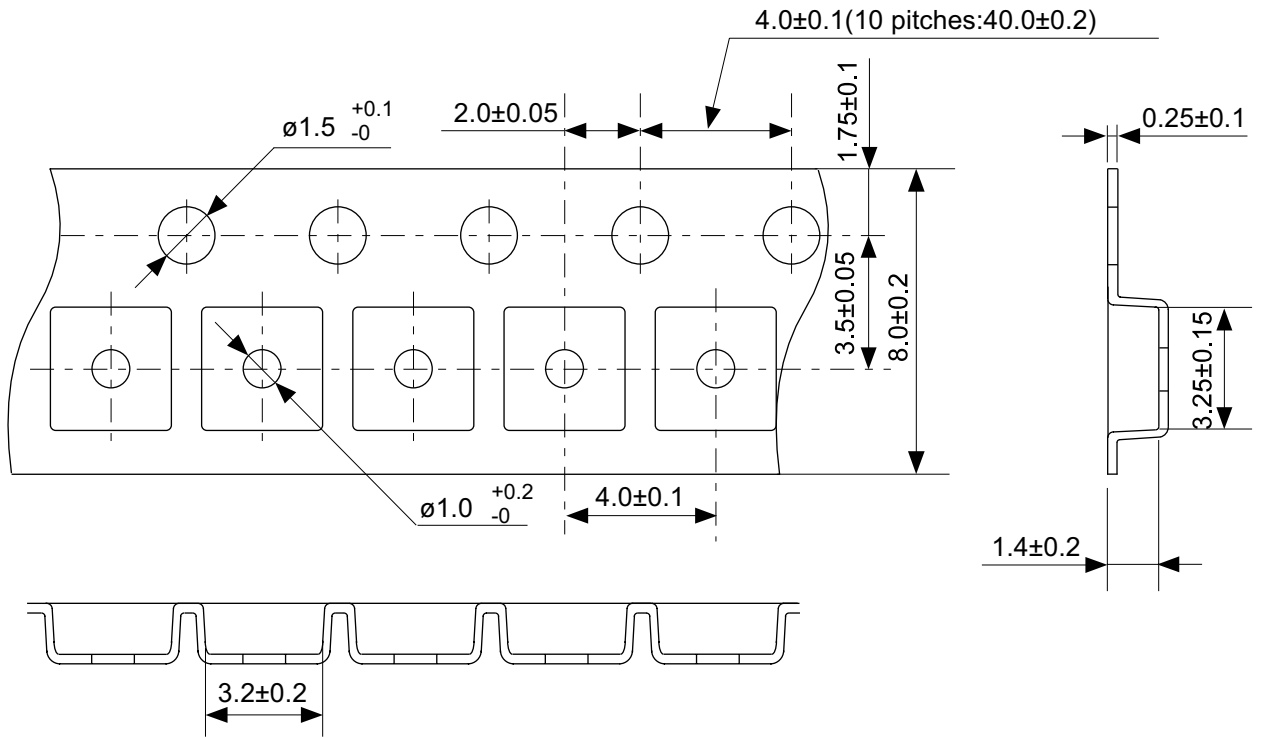

No. MP005-A-C-SD-2.1

TITLE	SOT235-A-Carrier Tape
No.	MP005-A-C-SD-2.1
SCALE	
UNIT	mm
Seiko Instruments Inc.	

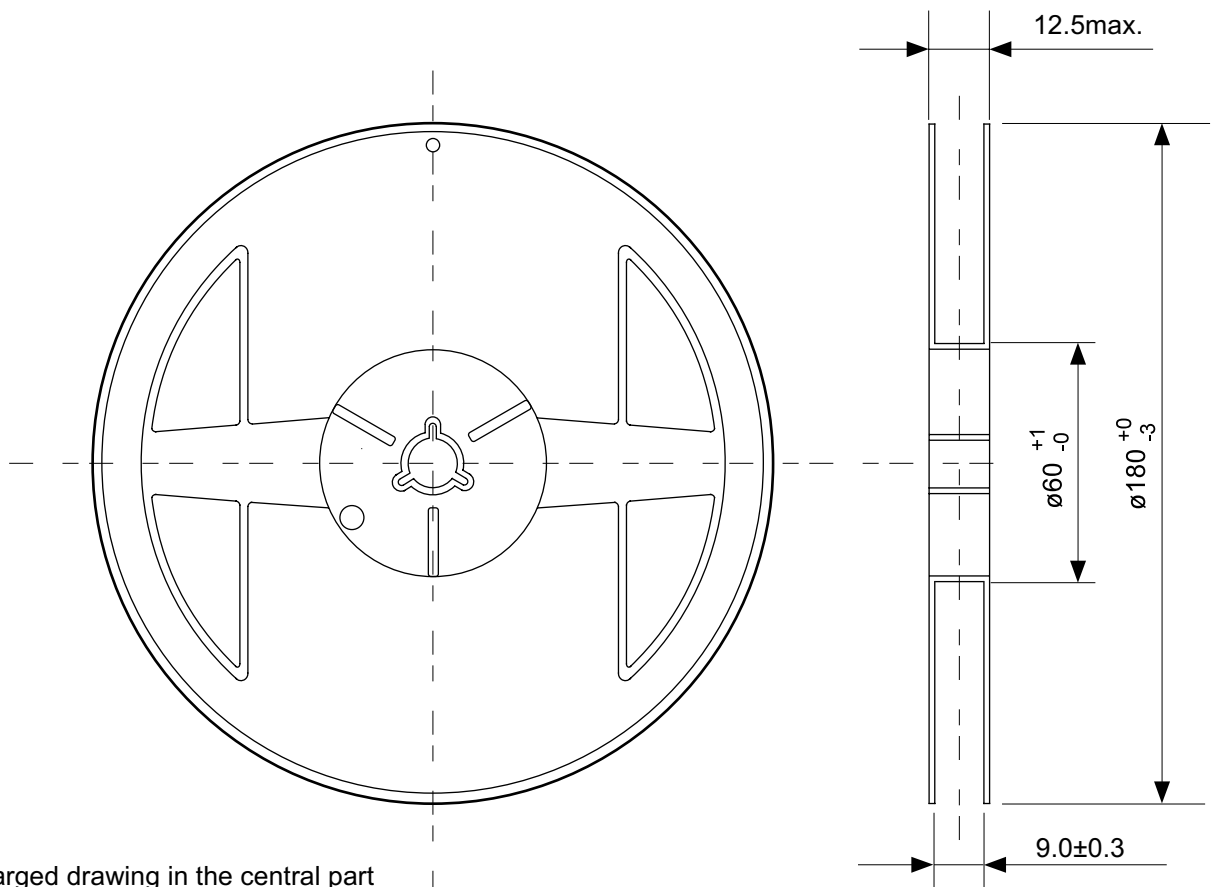

Enlarged drawing in the central part

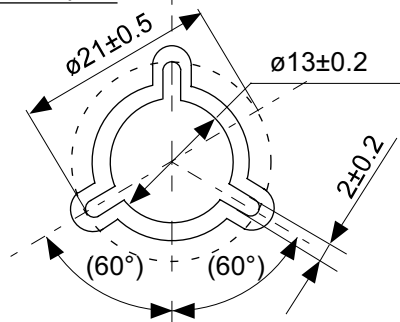

No. MP005-A-R-SD-1.1

TITLE	SOT235-A-Reel		
No.	MP005-A-R-SD-1.1		
SCALE		QTY.	3,000
UNIT	mm		
Seiko Instruments Inc.			

- The information described herein is subject to change without notice.
- Seiko Instruments Inc. is not responsible for any problems caused by circuits or diagrams described herein whose related industrial properties, patents, or other rights belong to third parties. The application circuit examples explain typical applications of the products, and do not guarantee the success of any specific mass-production design.
- When the products described herein are regulated products subject to the Wassenaar Arrangement or other agreements, they may not be exported without authorization from the appropriate governmental authority.
- Use of the information described herein for other purposes and/or reproduction or copying without the express permission of Seiko Instruments Inc. is strictly prohibited.
- The products described herein cannot be used as part of any device or equipment affecting the human body, such as exercise equipment, medical equipment, security systems, gas equipment, or any apparatus installed in airplanes and other vehicles, without prior written permission of Seiko Instruments Inc.
- Although Seiko Instruments Inc. exerts the greatest possible effort to ensure high quality and reliability, the failure or malfunction of semiconductor products may occur. The user of these products should therefore give thorough consideration to safety design, including redundancy, fire-prevention measures, and malfunction prevention, to prevent any accidents, fires, or community damage that may ensue.