



# NPN SILICON HIGH FREQUENCY TRANSISTOR

## UPA800T

### FEATURES

- **SMALL PACKAGE STYLE:**  
2 NE680 Die in a 2 mm x 1.25 mm package
- **LOW NOISE FIGURE:**  
NF = 1.9 dB TYP at 2 GHz
- **HIGH GAIN:**  
 $IS_{21}EI^2 = 7.5$  dB TYP at 2 GHz
- **EXCELLENT LOW VOLTAGE, LOW CURRENT PERFORMANCE**

### DESCRIPTION

NEC's UPA800T is two NPN high frequency silicon epitaxial transistors encapsulated in an ultra small 6 pin SMT package. Each transistor is independently mounted and easily configured for either dual transistor or cascode operation. The high  $f_T$ , low voltage bias and small size make this device ideally suited for pager and other hand-held wireless applications.

### OUTLINE DIMENSIONS (Units in mm)

PACKAGE OUTLINE S06  
(Top View)

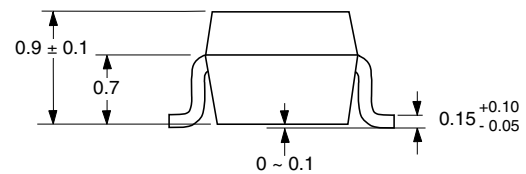
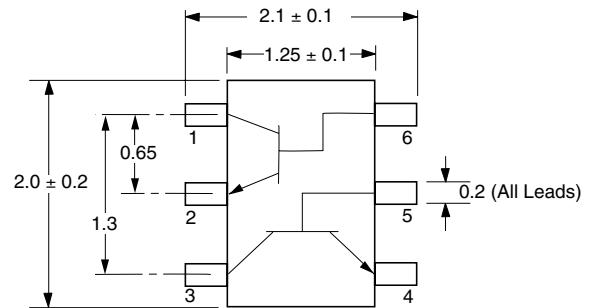

**PIN OUT**

1. Collector Transistor 1
2. Emitter Transistor 1
3. Collector Transistor 2
4. Emitter Transistor 2
5. Base Transistor 2
6. Base Transistor 1

**Note:**

Pin 3 is identified with a circle on the bottom of the package.

### ELECTRICAL CHARACTERISTICS (T<sub>A</sub> = 25°C)

PART NUMBER PACKAGE OUTLINE			UPA800T S06		
SYMBOLS	PARAMETERS AND CONDITIONS	UNITS	MIN	TYP	MAX
I <sub>CBO</sub>	Collector Cutoff Current at V <sub>CB</sub> = 10 V, I <sub>E</sub> = 0	μA			1.0
I <sub>EBO</sub>	Emitter Cutoff Current at V <sub>EB</sub> = 1 V, I <sub>C</sub> = 0	μA			1.0
h <sub>FE</sub> <sup>1</sup>	Forward Current Gain at V <sub>CE</sub> = 3 V, I <sub>C</sub> = 5 mA		80	120	200
f <sub>T</sub>	Gain Bandwidth at V <sub>CE</sub> = 3 V, I <sub>C</sub> = 5 mA	GHz	5.5	8.0	
C <sub>re</sub> <sup>2</sup>	Feedback Capacitance at V <sub>CB</sub> = 3 V, I <sub>E</sub> = 0, f = 1 MHz	pF		0.3	0.7
IS <sub>21</sub> EI <sup>2</sup>	Insertion Power Gain at V <sub>CE</sub> = 3 V, I <sub>C</sub> = 5 mA, f = 2 GHz	dB	5.5	7.5	
NF	Noise Figure at V <sub>CE</sub> = 3 V, I <sub>C</sub> = 5 mA, f = 2 GHz	dB		1.9	3.2

Notes: 1. Pulsed measurement, pulse width ≤ 350 μs, duty cycle ≤ 2 %.

2. The emitter terminal should be connected to the ground terminal of the 3 terminal capacitance bridge.

For Tape and Reel version use part number UPA800T-T1, 3K per reel..

# UPA800T

## ABSOLUTE MAXIMUM RATINGS<sup>1</sup> (T<sub>A</sub> = 25°C)

SYMBOLS	PARAMETERS	UNITS	RATINGS
V <sub>CB0</sub>	Collector to Base Voltage	V	20
V <sub>CE0</sub>	Collector to Emitter Voltage	V	10
V <sub>EB0</sub>	Emitter to Base Voltage	V	1.5
I <sub>C</sub>	Collector Current	mA	35
P <sub>T</sub>	Total Power Dissipation		
	1 Die	mW	110
	2 Die	mW	200
T <sub>J</sub>	Junction Temperature	°C	150
T <sub>STG</sub>	Storage Temperature	°C	-65 to +150

Note:

1. Operation in excess of any one of these parameters may result in permanent damage.

## ORDERING INFORMATION

PART NUMBER	QUANTITY	PACKAGING
UPA800T-T1-A	3000	Tape & Reel

## TYPICAL SCATTERING PARAMETERS

### UPA800T (Q1)

V<sub>CE</sub> = .5V, I<sub>C</sub> = .5mA, CE; h<sub>FE</sub> = 112

Frequency GHz	S <sub>11</sub>		S <sub>21</sub>		S <sub>12</sub>		S <sub>22</sub>		K	MAG <sup>1</sup> (dB)
	MAG	ANG	MAG	ANG	MAG	ANG	MAG	ANG		
0.250	0.966	-16.00	1.722	162.10	0.055	77.50	0.983	-9.10	0.147	14.957
0.400	0.943	-25.30	1.702	152.50	0.085	70.70	0.965	-14.20	0.214	13.015
0.600	0.906	-36.90	1.659	140.90	0.120	62.90	0.934	-20.50	0.286	11.407
0.800	0.859	-48.20	1.611	129.70	0.150	55.50	0.900	-26.50	0.359	10.310
1.000	0.810	-58.80	1.544	119.40	0.175	48.70	0.864	-31.90	0.432	9.456
1.500	0.662	-83.70	1.423	95.40	0.216	34.40	0.778	-44.40	0.622	8.188
2.000	0.514	-109.60	1.288	74.30	0.234	23.10	0.710	-55.20	0.806	7.407
2.500	0.394	-143.00	1.163	55.10	0.232	14.10	0.663	-63.70	0.985	7.001
3.000	0.348	176.20	1.034	38.80	0.220	8.80	0.634	-70.20	1.153	4.345
3.500	0.384	141.10	0.905	25.30	0.204	7.90	0.621	-75.10	1.310	3.131
4.000	0.442	119.70	0.805	15.20	0.197	11.70	0.607	-80.30	1.420	2.262
4.500	0.484	108.00	0.735	7.60	0.206	17.70	0.586	-87.50	1.453	1.531
5.000	0.503	101.60	0.701	1.60	0.238	22.60	0.550	-98.00	1.386	0.989

### UPA800T (Q2)

V<sub>CE</sub> = .5V, I<sub>C</sub> = .5mA, CE; h<sub>FE</sub> = 107

Frequency GHz	S <sub>11</sub>		S <sub>21</sub>		S <sub>12</sub>		S <sub>22</sub>		K	MAG <sup>1</sup> (dB)
	MAG	ANG	MAG	ANG	MAG	ANG	MAG	ANG		
0.250	0.967	-16.40	1.707	162.30	0.049	77.30	0.983	-8.60	0.144	15.420
0.400	0.947	-26.00	1.688	152.80	0.076	70.30	0.967	-13.50	0.208	13.466
0.600	0.913	-37.80	1.646	141.30	0.107	62.40	0.940	-19.60	0.276	11.870
0.800	0.871	-49.30	1.599	130.20	0.135	54.70	0.908	-25.30	0.350	10.735
1.000	0.828	-60.10	1.533	120.00	0.157	47.80	0.875	-30.60	0.418	9.896
1.500	0.695	-85.20	1.420	96.00	0.195	32.90	0.794	-42.80	0.609	8.623
2.000	0.560	-111.10	1.292	74.50	0.213	20.40	0.727	-53.80	0.798	7.829
2.500	0.448	-142.50	1.174	54.50	0.213	10.30	0.675	-63.50	0.991	7.413
3.000	0.394	-179.10	1.049	37.20	0.202	3.60	0.644	-71.30	1.181	4.580
3.500	0.409	147.80	0.923	22.50	0.185	1.50	0.629	-77.90	1.380	3.305
4.000	0.451	125.20	0.823	10.90	0.175	4.70	0.613	-84.40	1.548	2.362
4.500	0.483	111.60	0.751	1.90	0.181	11.10	0.590	-92.70	1.623	1.554
5.000	0.498	103.20	0.715	-5.60	0.211	16.80	0.549	-104.30	1.549	0.934

Note:

1. Gain Calculations:

$$\text{MAG} = \frac{|S_{21}|}{|S_{12}|} (K \pm \sqrt{K^2 - 1}). \text{ When } K \leq 1, \text{ MAG is undefined and MSG values are used. } \text{MSG} = \frac{|S_{21}|}{|S_{12}|}, K = \frac{1 + |\Delta|^2 - |S_{11}|^2 - |S_{22}|^2}{2 |S_{12} S_{21}|}, \Delta = S_{11} S_{22} - S_{21} S_{12}$$

MAG = Maximum Available Gain

MSG = Maximum Stable Gain

TYPICAL SCATTERING PARAMETERS

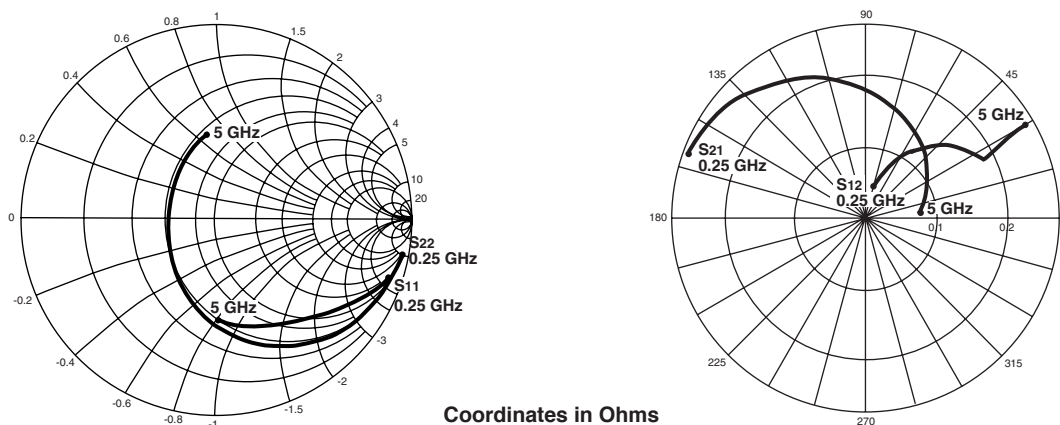

Coordinates in Ohms  
 Frequency in GHz  
 V<sub>CE</sub> = 1 V, I<sub>c</sub> = 1 mA,  
 h<sub>FE</sub> = 112

UPA800T (Q1)

V<sub>CE</sub> = 1V, I<sub>c</sub> = 1mA, CE; h<sub>FE</sub> = 112

Frequency GHz	S <sub>11</sub>		S <sub>21</sub>		S <sub>12</sub>		S <sub>22</sub>		K	MAG <sup>1</sup> (dB)
	MAG	ANG	MAG	ANG	MAG	ANG	MAG	ANG		
0.250	0.940	-18.90	3.202	160.10	0.045	76.20	0.972	-10.30	0.166	18.522
0.400	0.905	-29.70	3.115	149.80	0.069	69.30	0.943	-15.90	0.233	16.546
0.600	0.846	-43.00	2.960	137.70	0.095	61.40	0.897	-22.30	0.313	14.936
0.800	0.778	-55.50	2.793	126.30	0.117	54.60	0.849	-28.00	0.396	13.779
1.000	0.710	-66.90	2.604	116.10	0.133	48.80	0.804	-32.90	0.479	12.918
1.500	0.532	-92.30	2.215	93.30	0.160	38.60	0.711	-43.30	0.694	11.413
2.000	0.378	-119.10	1.881	74.00	0.174	32.00	0.653	-52.30	0.883	10.338
2.500	0.267	-156.40	1.621	57.00	0.181	28.00	0.614	-59.70	1.048	8.180
3.000	0.251	157.60	1.398	42.50	0.186	26.20	0.595	-65.60	1.157	6.359
3.500	0.309	125.10	1.211	30.30	0.192	26.60	0.583	-70.20	1.220	5.167
4.000	0.372	108.20	1.073	20.60	0.206	28.10	0.569	-74.60	1.224	4.311
4.500	0.413	99.90	0.981	12.70	0.229	29.60	0.547	-80.40	1.198	3.630
5.000	0.430	96.20	0.932	5.80	0.265	30.10	0.513	-88.50	1.145	3.151

UPA800T (Q2)

V<sub>CE</sub> = 1V, I<sub>c</sub> = 1mA, CE; h<sub>FE</sub> = 107

Frequency GHz	S <sub>11</sub>		S <sub>21</sub>		S <sub>12</sub>		S <sub>22</sub>		K	MAG <sup>1</sup> (dB)
	MAG	ANG	MAG	ANG	MAG	ANG	MAG	ANG		
0.250	0.941	-19.30	3.214	160.40	0.039	76.10	0.975	-9.60	0.159	19.160
0.400	0.908	-30.30	3.130	150.20	0.060	68.90	0.949	-14.80	0.227	17.174
0.600	0.856	-43.80	2.979	138.20	0.083	60.80	0.907	-20.90	0.305	15.550
0.800	0.795	-56.60	2.816	126.90	0.102	53.80	0.863	-26.20	0.385	14.410
1.000	0.734	-68.20	2.634	116.80	0.116	47.80	0.822	-31.00	0.463	13.562
1.500	0.571	-94.10	2.259	93.80	0.140	36.80	0.734	-41.10	0.680	12.078
2.000	0.428	-120.60	1.934	74.00	0.152	29.30	0.673	-50.20	0.886	11.046
2.500	0.323	-154.40	1.678	56.20	0.158	24.60	0.633	-58.40	1.063	8.727
3.000	0.292	165.70	1.453	40.60	0.161	22.40	0.610	-65.50	1.203	6.834
3.500	0.326	133.50	1.262	27.20	0.166	22.70	0.599	-71.50	1.282	5.623
4.000	0.376	114.20	1.118	16.20	0.178	24.40	0.585	-77.20	1.299	4.700
4.500	0.409	103.50	1.018	7.10	0.200	26.10	0.564	-83.80	1.272	3.933
5.000	0.423	97.70	0.965	-1.00	0.236	26.50	0.528	-92.90	1.205	3.380

Note:

1. Gain Calculations:

$$MAG = \frac{|S_{21}|}{|S_{12}|} (K \pm \sqrt{K^2 - 1}). \text{ When } K \leq 1, \text{ MAG is undefined and MSG values are used. } MSG = \frac{|S_{21}|}{|S_{12}|}, K = \frac{1 + |\Delta|^2 - |S_{11}|^2 - |S_{22}|^2}{2 |S_{12} S_{21}|}, \Delta = S_{11} S_{22} - S_{21} S_{12}$$

MAG = Maximum Available Gain

MSG = Maximum Stable Gain

# UPA800T

## TYPICAL SCATTERING PARAMETERS

### UPA800T (Q1)

V<sub>CE</sub> = 2 V, I<sub>c</sub> = 5 mA, CE; h<sub>FE</sub> = 112

Frequency GHz	S <sub>11</sub>		S <sub>21</sub>		S <sub>12</sub>		S <sub>22</sub>		K	MAG <sup>1</sup> (dB)
	MAG	ANG	MAG	ANG	MAG	ANG	MAG	ANG		
0.250	0.734	-38.60	11.103	143.00	0.033	68.60	0.868	-18.50	0.353	25.269
0.400	0.611	-56.60	9.478	127.60	0.046	62.70	0.770	-24.10	0.668	23.140
0.600	0.480	-74.00	7.583	112.90	0.059	59.30	0.677	-27.60	0.795	21.090
0.800	0.381	-87.20	6.193	102.00	0.070	58.20	0.620	-29.60	0.892	19.468
1.000	0.308	-98.10	5.198	93.50	0.080	57.80	0.584	-31.30	1.027	18.127
1.500	0.177	-123.80	3.692	76.80	0.107	56.90	0.540	-36.50	1.082	14.369
2.000	0.097	-171.70	2.863	63.00	0.135	54.40	0.521	-43.70	1.092	11.519
2.500	0.123	122.90	2.329	50.70	0.162	51.20	0.516	-51.60	1.092	9.731
3.000	0.200	96.70	1.952	40.00	0.187	47.60	0.512	-58.50	1.086	8.396
3.500	0.271	86.10	1.677	30.50	0.211	44.10	0.505	-64.00	1.069	7.399
4.000	0.317	81.70	1.485	22.30	0.236	41.00	0.489	-68.30	1.052	6.596
4.500	0.339	81.10	1.358	15.00	0.266	37.90	0.466	-72.40	1.026	6.084
5.000	0.343	82.90	1.284	8.10	0.303	34.60	0.434	-77.60	0.997	6.271

### UPA800T (Q2)

V<sub>CE</sub> = 2 V, I<sub>c</sub> = 5 mA, CE; h<sub>FE</sub> = 107

Frequency GHz	S <sub>11</sub>		S <sub>21</sub>		S <sub>12</sub>		S <sub>22</sub>		K	MAG <sup>1</sup> (dB)
	MAG	ANG	MAG	ANG	MAG	ANG	MAG	ANG		
0.250	0.742	-38.90	11.219	143.90	0.029	69.20	0.885	-16.50	0.330	25.876
0.400	0.629	-57.50	9.662	128.60	0.039	62.00	0.797	-21.60	0.484	23.940
0.600	0.506	-75.80	7.801	113.70	0.050	58.00	0.712	-25.00	0.650	21.932
0.800	0.412	-89.80	6.409	102.60	0.059	56.50	0.659	-27.00	0.782	20.359
1.000	0.343	-101.40	5.400	93.80	0.067	56.10	0.624	-28.70	0.888	19.063
1.500	0.220	-127.00	3.859	76.50	0.089	55.30	0.580	-33.80	1.042	15.116
2.000	0.142	-164.20	3.007	62.00	0.112	53.40	0.559	-40.90	1.107	12.295
2.500	0.139	143.40	2.457	48.80	0.135	50.20	0.547	-48.90	1.126	10.443
3.000	0.197	110.70	2.063	36.90	0.158	46.30	0.541	-56.60	1.113	9.115
3.500	0.259	94.90	1.773	26.30	0.180	42.60	0.535	-63.10	1.092	8.082
4.000	0.304	87.30	1.565	16.90	0.204	39.10	0.523	-68.30	1.065	7.288
4.500	0.326	84.10	1.423	8.60	0.233	35.70	0.506	-73.40	1.031	6.779
5.000	0.332	83.90	1.338	0.80	0.270	31.90	0.477	-79.60	0.993	6.951

Note:

1. Gain Calculations:

$$\text{MAG} = \frac{|S_{21}|}{|S_{12}|} \left( K \pm \sqrt{K^2 - 1} \right). \text{ When } K \leq 1, \text{ MAG is undefined and MSG values are used. } \text{MSG} = \frac{|S_{21}|}{|S_{12}|}, K = \frac{1 + |\Delta|^2 - |S_{11}|^2 - |S_{22}|^2}{2 |S_{12} S_{21}|}, \Delta = S_{11} S_{22} - S_{21} S_{12}$$

MAG = Maximum Available Gain

MSG = Maximum Stable Gain

TYPICAL SCATTERING PARAMETERS

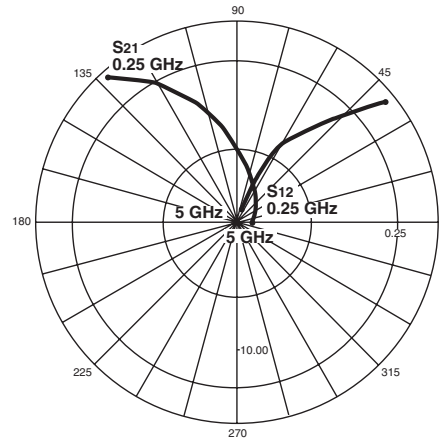
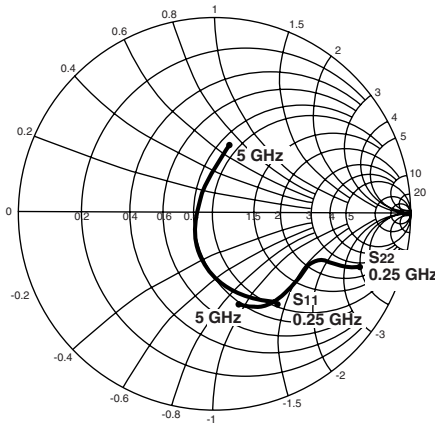

Coordinates in Ohms  
Frequency in GHz  
V<sub>CE</sub> = 3 V, I<sub>c</sub> = 10 mA  
h<sub>FE</sub> = 112

UPA800T (Q1)

V<sub>CE</sub> = 3V, I<sub>c</sub> = 10 mA, CE; h<sub>FE</sub> = 112

Frequency GHz	S <sub>11</sub>		S <sub>21</sub>		S <sub>12</sub>		S <sub>22</sub>		K	MAG <sup>1</sup> (dB)
	MAG	ANG	MAG	ANG	MAG	ANG	MAG	ANG		
0.250	0.550	-54.70	15.326	131.00	0.026	66.80	0.787	-20.00	0.513	27.705
0.400	0.414	-74.40	11.717	115.40	0.036	64.10	0.687	-22.50	0.698	25.125
0.600	0.308	-91.40	8.623	102.50	0.047	64.40	0.619	-23.20	0.853	22.636
0.800	0.237	-104.90	6.763	93.60	0.057	65.10	0.586	-23.90	0.955	20.743
1.000	0.188	-116.80	5.553	86.40	0.068	65.30	0.567	-25.20	1.013	18.430
1.500	0.105	-152.20	3.844	72.00	0.097	64.30	0.547	-30.70	1.072	14.338
2.000	0.091	142.00	2.950	59.60	0.126	61.00	0.541	-38.50	1.082	11.944
2.500	0.154	102.90	2.383	48.20	0.154	56.90	0.540	-46.90	1.071	10.265
3.000	0.230	87.40	1.988	38.10	0.179	52.70	0.539	-54.10	1.055	9.016
3.500	0.294	80.20	1.703	29.10	0.204	48.80	0.534	-59.80	1.029	8.168
4.000	0.334	77.20	1.504	21.30	0.229	45.40	0.521	-64.30	1.009	7.588
4.500	0.352	77.10	1.374	14.30	0.260	42.20	0.501	-68.70	0.979	7.230
5.000	0.351	79.20	1.298	7.70	0.297	38.70	0.474	-73.90	0.949	6.405

UPA800T (Q2)

V<sub>CE</sub> = 3V, I<sub>c</sub> = 10 mA, CE; h<sub>FE</sub> = 107

Frequency GHz	S <sub>11</sub>		S <sub>21</sub>		S <sub>12</sub>		S <sub>22</sub>		K	MAG <sup>1</sup> (dB)
	MAG	ANG	MAG	ANG	MAG	ANG	MAG	ANG		
0.250	0.563	-55.80	15.579	131.90	0.022	66.50	0.816	-17.60	0.490	28.501
0.400	0.436	-76.70	12.036	116.20	0.030	62.70	0.725	-20.00	0.682	26.034
0.600	0.336	-95.10	8.920	103.00	0.039	62.90	0.664	-20.80	0.841	23.593
0.800	0.268	-109.20	7.018	93.70	0.047	63.60	0.633	-21.70	0.955	21.741
1.000	0.223	-121.00	5.776	86.40	0.056	64.10	0.615	-23.10	1.018	19.312
1.500	0.145	-151.60	4.016	71.40	0.079	63.70	0.595	-28.50	1.094	15.193
2.000	0.117	161.50	3.095	58.20	0.104	60.90	0.585	-36.10	1.101	12.803
2.500	0.155	119.60	2.510	46.00	0.128	56.70	0.579	-44.50	1.091	11.088
3.000	0.221	98.40	2.100	34.70	0.151	52.30	0.576	-52.40	1.065	9.879
3.500	0.280	87.40	1.798	24.60	0.174	48.10	0.572	-59.20	1.033	9.027
4.000	0.320	81.50	1.583	15.70	0.198	44.30	0.563	-64.70	1.003	8.670
4.500	0.338	79.30	1.438	7.60	0.228	40.50	0.549	-70.00	0.963	7.998
5.000	0.340	79.60	1.351	0.10	0.265	36.70	0.526	-76.30	0.923	7.074

Note:

1. Gain Calculations:

$$MAG = \frac{|S_{21}|}{|S_{12}|} (K \pm \sqrt{K^2 - 1})$$

When  $K \leq 1$ , MAG is undefined and MSG values are used.  $MSG = \frac{|S_{21}|}{|S_{12}|}$ ,  $K = \frac{1 + |\Delta|^2 - |S_{11}|^2 - |S_{22}|^2}{2 |S_{12} S_{21}|}$ ,  $\Delta = S_{11} S_{22} - S_{21} S_{12}$

MAG = Maximum Available Gain

MSG = Maximum Stable Gain

TYPICAL SCATTERING PARAMETERS

UPA800T (Q1)

V<sub>CE</sub> = 5 V, I<sub>c</sub> = 10 mA, CE; h<sub>FE</sub> = 112

Frequency GHz	S <sub>11</sub>		S <sub>21</sub>		S <sub>12</sub>		S <sub>22</sub>		K	MAG <sup>1</sup> (dB)
	MAG	ANG	MAG	ANG	MAG	ANG	MAG	ANG		
0.25	0.574	-51.50	15.447	132.20	0.025	68.00	0.807	-18.40	0.495	27.909
0.40	0.434	-70.10	11.889	116.50	0.034	64.40	0.712	-20.90	0.687	25.437
0.60	0.321	-86.20	8.790	103.50	0.044	64.90	0.648	-21.70	0.843	23.005
0.80	0.245	-98.30	6.904	94.50	0.054	65.50	0.616	-22.60	0.940	21.067
1.00	0.192	-108.70	5.675	87.30	0.065	65.90	0.598	-23.90	0.992	19.411
1.50	0.097	-139.40	3.933	73.00	0.092	65.00	0.579	-29.30	1.057	14.846
2.00	0.069	145.20	3.019	60.50	0.119	62.00	0.572	-36.90	1.073	12.390
2.50	0.135	99.90	2.438	49.20	0.146	58.10	0.571	-44.90	1.060	10.726
3.00	0.213	85.30	2.035	39.10	0.170	54.10	0.571	-51.90	1.042	9.532
3.50	0.277	78.80	1.743	30.10	0.194	50.50	0.567	-57.50	1.015	8.779
4.00	0.318	76.30	1.537	22.30	0.218	47.30	0.556	-61.90	0.993	8.482
4.50	0.335	76.40	1.403	15.40	0.248	44.30	0.539	-66.20	0.962	7.526
5.00	0.334	78.80	1.325	8.80	0.285	41.10	0.515	-71.40	0.926	6.674

UPA800T2 (Q2)

V<sub>CE</sub> = 5V, I<sub>c</sub> = 10 mA, CE; h<sub>FE</sub> = 107

Frequency GHz	S <sub>11</sub>		S <sub>21</sub>		S <sub>12</sub>		S <sub>22</sub>		K	MAG <sup>1</sup> (dB)
	MAG	ANG	MAG	ANG	MAG	ANG	MAG	ANG		
0.25	0.586	-52.30	15.769	133.30	0.020	67.00	0.836	-16.00	0.483	28.968
0.40	0.455	-72.20	12.274	117.50	0.028	63.70	0.753	-18.50	0.660	26.418
0.60	0.346	-89.60	9.139	104.20	0.036	63.60	0.694	-19.40	0.830	24.046
0.80	0.273	-102.80	7.204	94.80	0.044	64.30	0.664	-20.50	0.936	22.141
1.00	0.224	-113.70	5.935	87.40	0.052	64.90	0.648	-21.90	1.002	20.276
1.50	0.136	-141.60	4.130	72.40	0.074	64.70	0.629	-27.20	1.073	15.817
2.00	0.096	168.00	3.184	59.30	0.097	62.30	0.620	-34.60	1.084	13.398
2.50	0.132	119.10	2.584	47.10	0.119	58.50	0.615	-42.70	1.076	11.682
3.00	0.199	97.00	2.161	35.90	0.142	54.40	0.613	-50.40	1.042	10.568
3.50	0.260	86.30	1.851	25.80	0.164	50.30	0.610	-57.00	1.008	9.994
4.00	0.300	80.80	1.628	16.90	0.187	46.80	0.604	-62.50	0.974	9.398
4.50	0.318	78.70	1.477	8.90	0.216	43.40	0.592	-67.80	0.933	8.349
5.00	0.319	79.50	1.388	1.50	0.252	39.80	0.573	-74.10	0.889	7.410

Note:

1. Gain Calculations:

$$MAG = \frac{|S_{21}|}{|S_{12}|} (K \pm \sqrt{K^2 - 1}). \text{ When } K \leq 1, \text{ MAG is undefined and MSG values are used. } MSG = \frac{|S_{21}|}{|S_{12}|}, K = \frac{1 + |\Delta|^2 - |S_{11}|^2 - |S_{22}|^2}{2 |S_{12} S_{21}|}, \Delta = S_{11} S_{22} - S_{21} S_{12}$$

MAG = Maximum Available Gain

MSG = Maximum Stable Gain

**UPA800T NONLINEAR MODEL**

**BJT NONLINEAR MODEL PARAMETERS(1)**

Parameters	Q1, Q2	Parameters	Q1, Q2
IS	3.84e-16	MJC	0.5
BF	124.9	XCJC	0
NF	1.04	CJS	0
VAF	11.87	VJS	0.75
IKF	0.027	MJS	0
ISE	1e-14	FC	0.5
NE	2.17	TF	10e-12
BR	1.0	XTF	18.0
NR	1.05	VTF	19.12
VAR	Infinity	ITF	0.082
IKR	Infinity	PTF	0
ISC	0	TR	0.635e-9
NC	2.0	EG	1.11
RE	0.6	XTB	0
RB	17.88	XTI	3
RBM	1.02	KF	0
IRB	4.01e-4	AF	1
RC	10.46		
CJE	0.358e-12		
VJE	0.711		
MJE	0.5		
CJC	0.21e-12		
VJC	0.791		

(1) Gummel-Poon Model

**UNITS**

Parameter	Units
time	seconds
capacitance	farads
inductance	henries
resistance	ohms
voltage	volts
current	amps

**MODEL RANGE**

Frequency: 0.1 to 3.0 GHz

Bias:  $V_{CE} = 0.5 \text{ V to } 5 \text{ V}$ ,  $I_C = 0.5 \text{ mA to } 10 \text{ mA}$

Date: 10/98

## UPA800T NONLINEAR MODEL

## SCHEMATIC

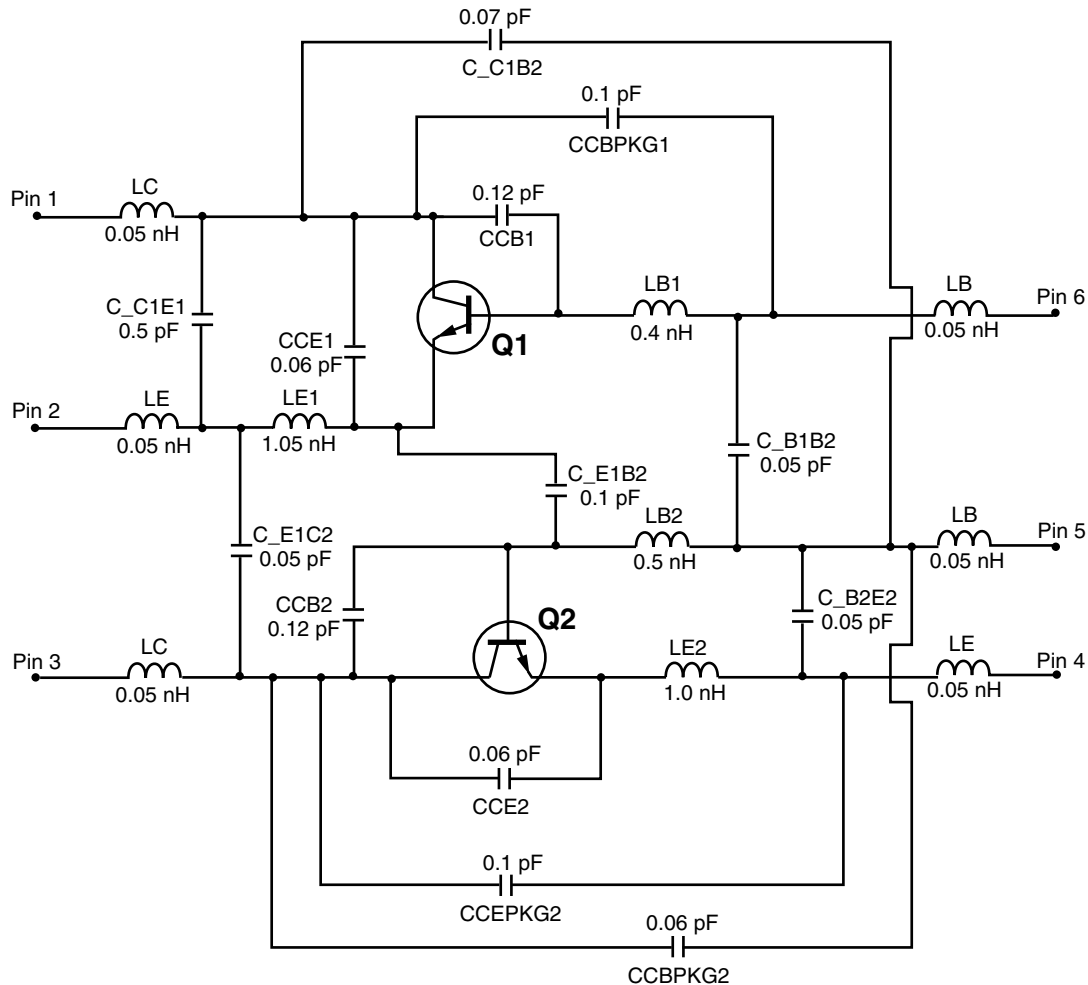

## MODEL RANGE

Frequency: 0.1 to 3.0 GHz

Bias:  $V_{CE} = 0.5$  V to 5 V,  $I_C = 0.5$  mA to 10 mA

Date: 10/98

## Life Support Applications

These NEC products are not intended for use in life support devices, appliances, or systems where the malfunction of these products can reasonably be expected to result in personal injury. The customers of CEL using or selling these products for use in such applications do so at their own risk and agree to fully indemnify CEL for all damages resulting from such improper use or sale.

EXCLUSIVE NORTH AMERICAN AGENT FOR **NEC** RF, MICROWAVE & OPTOELECTRONIC SEMICONDUCTORS
**CEL CALIFORNIA EASTERN LABORATORIES** • Headquarters • 4590 Patrick Henry Drive • Santa Clara, CA 95054-1817 • (408) 988-3500 • Telex 34-6393 • FAX (408) 988-0279
24-Hour Fax-On-Demand: 800-390-3232 (U.S. and Canada only) • Internet: <http://WWW.CEL.COM>

DATA SUBJECT TO CHANGE WITHOUT NOTICE

 PRINTED IN USA ON RECYCLED PAPER -12/98



Subject: Compliance with EU Directives

CEL certifies, to its knowledge, that semiconductor and laser products detailed below are compliant with the requirements of European Union (EU) Directive 2002/95/EC Restriction on Use of Hazardous Substances in electrical and electronic equipment (RoHS) and the requirements of EU Directive 2003/11/EC Restriction on Penta and Octa BDE.

CEL Pb-free products have the same base part number with a suffix added. The suffix –A indicates that the device is Pb-free. The –AZ suffix is used to designate devices containing Pb which are exempted from the requirement of RoHS directive (\*). In all cases the devices have Pb-free terminals. All devices with these suffixes meet the requirements of the RoHS directive.

This status is based on CEL’s understanding of the EU Directives and knowledge of the materials that go into its products as of the date of disclosure of this information.

Restricted Substance per RoHS	Concentration Limit per RoHS (values are not yet fixed)	Concentration contained in CEL devices	
		-A	-AZ
Lead (Pb)	< 1000 PPM	Not Detected	(*)
Mercury	< 1000 PPM	Not Detected	
Cadmium	< 100 PPM	Not Detected	
Hexavalent Chromium	< 1000 PPM	Not Detected	
PBB	< 1000 PPM	Not Detected	
PBDE	< 1000 PPM	Not Detected	

If you should have any additional questions regarding our devices and compliance to environmental standards, please do not hesitate to contact your local representative.

**Important Information and Disclaimer:** Information provided by CEL on its website or in other communications concerning the substance content of its products represents knowledge and belief as of the date that it is provided. CEL bases its knowledge and belief on information provided by third parties and makes no representation or warranty as to the accuracy of such information. Efforts are underway to better integrate information from third parties. CEL has taken and continues to take reasonable steps to provide representative and accurate information but may not have conducted destructive testing or chemical analysis on incoming materials and chemicals. CEL and CEL suppliers consider certain information to be proprietary, and thus CAS numbers and other limited information may not be available for release.

In no event shall CEL’s liability arising out of such information exceed the total purchase price of the CEL part(s) at issue sold by CEL to customer on an annual basis.

See CEL Terms and Conditions for additional clarification of warranties and liability.