

### HIGH-PERFORMANCE PRODUCTS

#### Description

SK1303 is a true differential LVDS Receiver/Driver. This device is designed to support frequency rates in excess of 800 MHz. SK1303 operates over an extended supply range of 3.0V to 5.5V and has a 100  $\Omega$  onchip termination resistor across its differential inputs.

When the differential LVDS inputs are left open or floating, the output Q will be at a logic LOW and Q\* at a logic HIGH.

#### Features

- Extended Supply Voltage Range: (VCC = 3.0V to 5.5V; VEE = 0V)
- 800 MHz Minimum Toggle Frequency
- Typical 350 mV Differential LVDS Inputs/Outputs
- Onchip 100  $\Omega$  Input Termination Resistor
- ESD Protection > 4000V
- Specified Over Industrial Temperature Range: -40°C to 85°C
- Available in both 8 pin SOIC and MSOP Packages
- Flammability Rating: UL-94 Code V-0
- Moisture sensitivity: Level 1

#### Functional Block Diagram

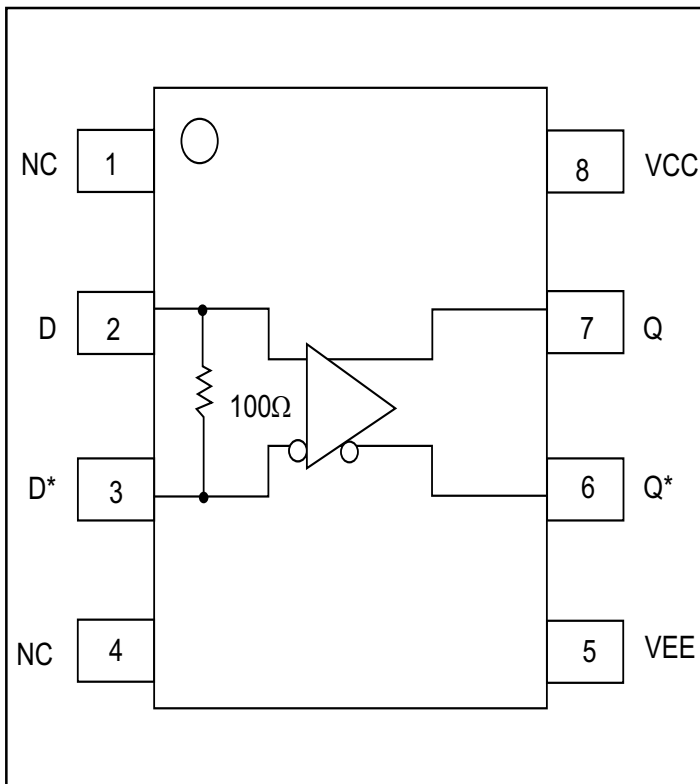

#### Pin Descriptions

Pin Name	Function
D, D*	Differential LVDS inputs
Q, Q*	Differential LVDS Outputs

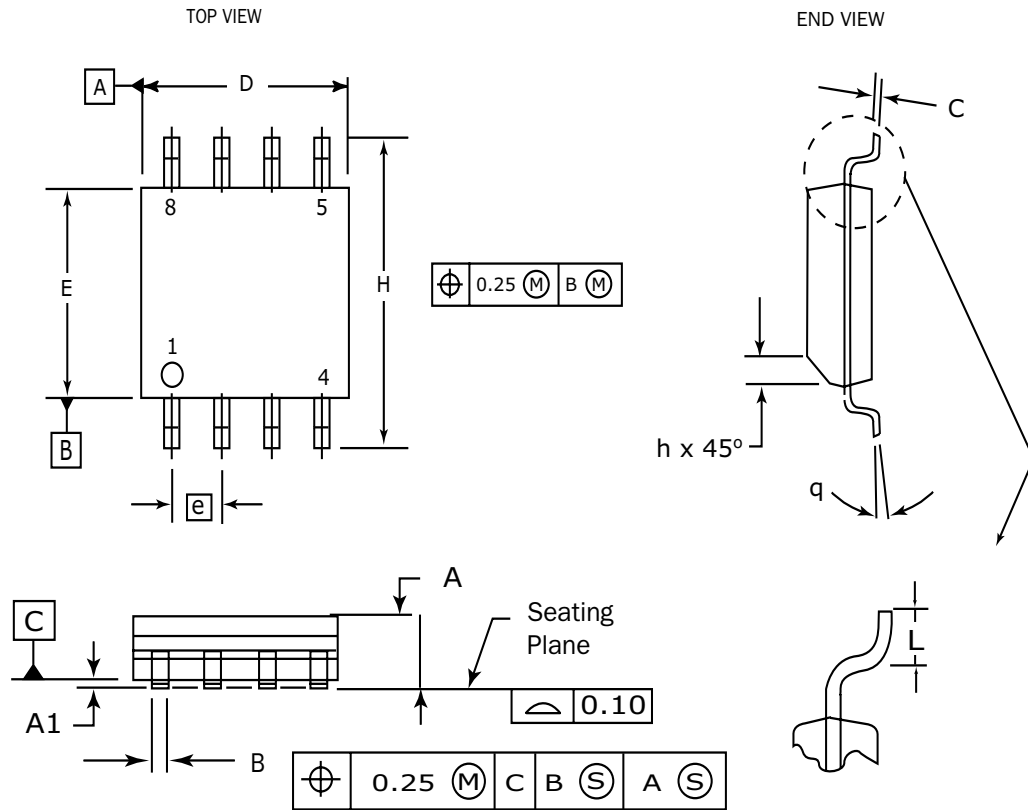
**8 Pin SOIC Package**

DIM	MILLIMETERS	
	MIN	MAX
A	1.35	1.75
A1	0.10	0.25
B	0.33	0.51
C	0.19	0.25
D	4.80	5.00
E	3.80	4.00
e	1.27 BSC	
H	5.80	6.20
h	0.25	0.50
L	0.40	1.27
θ	0°	8°

**NOTES:**

1. Dimensions are in millimeters.
2. Dimensions D and E do not include mold protrusion.
3. Maximum mold protrusion 0.15 per side.
4. Dimension B does not include Dambar protrusion. Allowable Dambar protrusion shall be 0.127 total in excess of the B dimension at maximum material condition.

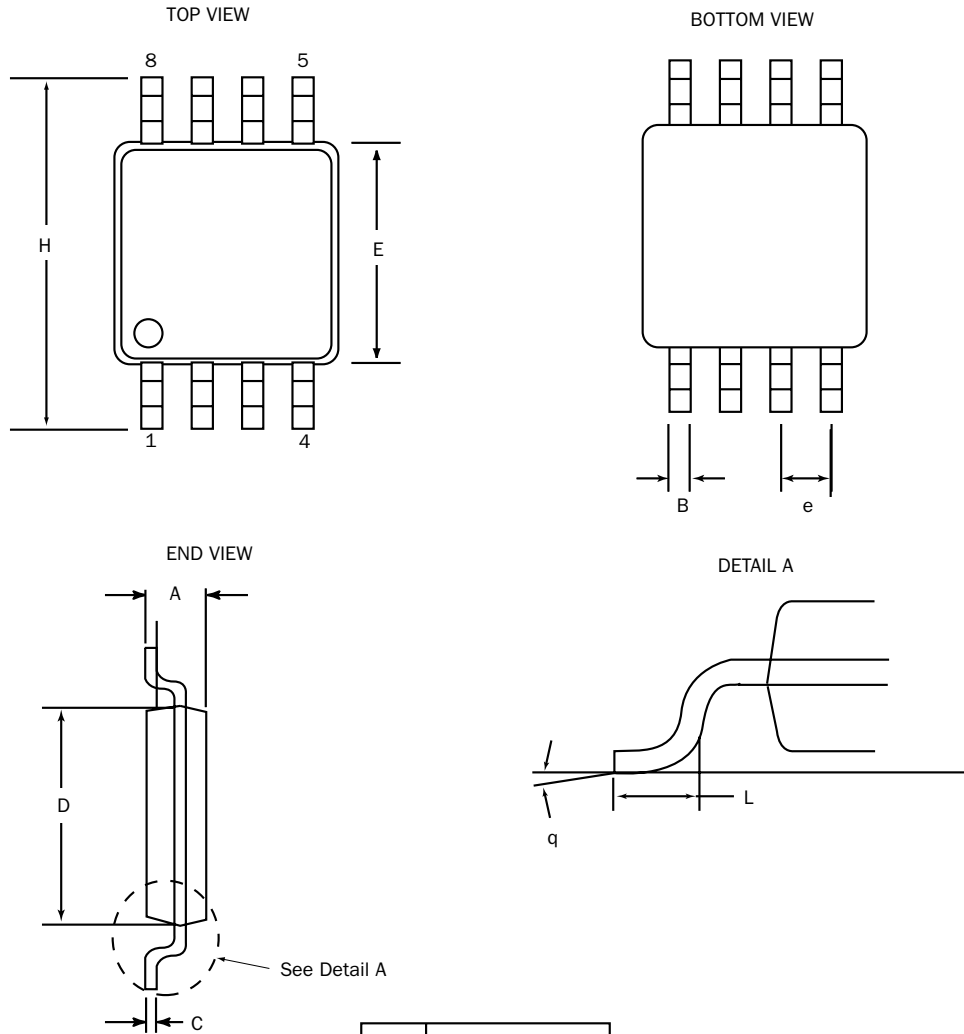
**8 Pin MSOP Package**

DIM	MILLIMETERS	
	MIN	MAX
A	0.94	1.1
B	0.25	0.40
C	0.13	0.23
D	2.90	3.10
E	2.90	3.10
e	0.65	BSC
H	4.75	5.1
L	0.4	0.7
θ	0°	6°

**NOTES:**

1. Dimensions are in mm
2. Controlling dimension: mm
3. Dimension does not include mold flash or protrusions, either of which shall not exceed 0.20

**HIGH-PERFORMANCE PRODUCTS**
**Absolute Maximum Ratings**

Symbol	Parameter	Value	Unit
V <sub>EE</sub>	Power Supply (V <sub>CC</sub> = 0V)	-6.0 to 0	V
V <sub>CC</sub>	Power Supply (V <sub>EE</sub> = 0V)	6.0 to 0	V
V <sub>I</sub>	Input Voltage (V <sub>CC</sub> = 0V, V <sub>I</sub> not more negative than V <sub>EE</sub> )	-6.0 to 0	V
V <sub>I</sub>	Input Voltage (V <sub>EE</sub> = 0V, V <sub>I</sub> not more positive than V <sub>CC</sub> )	6.0 to 0	V
I <sub>OUT</sub>	Output Current Continuous Surge	50 100	mA mA
T <sub>A</sub>	Operating Temperature Range	-40 to +85	°C
T <sub>stg</sub>	Storage Temperature	-65 to +150	°C
θ <sub>JA</sub> for SOIC	Thermal Resistance (Junction-to-Ambient) Still Air 500 lfpm	153.7 130	°C/W °C/W
θ <sub>JC</sub> for SOIC	Thermal Resistance (Junction-to-Case)	41.2	°C/W
θ <sub>JA</sub> for MSOP	Thermal Resistance (Junction-to-Ambient) Still Air 500 lfpm (>2 layers)	206.3 140	°C/W °C/W
θ <sub>JC</sub> for MSOP	Thermal Resistance (Junction-to-Case)	39.1	°C/W
T <sub>sol</sub>	Solder Temperature (<2 to 3 seconds: 245°C desired)	265	°C

\* Maximum Ratings are those values beyond which damage to the device may occur.

**DC Characteristics**
**SK1303 LVDS Input DC Electrical Characteristics**

(V<sub>CC</sub> = +3.0V to +5.5V; V<sub>EE</sub> = 0V)

Symbol	Characteristic	T <sub>A</sub> = - 40°C			T <sub>A</sub> = 0°C			T <sub>A</sub> = + 25°C			T <sub>A</sub> = + 85°C			Unit
		Min	Typ	Max	Min	Typ	Max	Min	Typ	Max	Min	Typ	Max	
V <sub>IH</sub>	Input High Voltage	0.9		2.6	0.9		2.6	0.9		2.6	0.9		2.6	V
V <sub>IL</sub>	Input Low Voltage	0.65		2.40	0.65		2.40	0.65		2.40	0.65		2.40	V
R <sub>IN</sub>	Input Impedance	79	100	121	79	100	121	79	100	121	79	100	121	Ω
V <sub>PP</sub>	Minimum Peak-to-Peak Input Swing	100		1000	100		1000	100		1000	100		1000	mV
I <sub>CC</sub>	Supply Current			45			45			45			45	mA

**HIGH-PERFORMANCE PRODUCTS**
**DC Characteristics (Continued)**
**SK1303 LVDS Outputs DC Electrical Characteristics**

(VCC = +3.0V to +5.5V; VEE = 0V)

Symbol	Characteristic	TA = - 40°C			TA = 0°C			TA = + 25°C			TA = + 85°C			Unit
		Min	Typ	Max	Min	Typ	Max	Min	Typ	Max	Min	Typ	Max	
V <sub>OH</sub>	Output High Voltage	1.25		1.8	1.25		1.8	1.25		1.8	1.25		1.8	V
V <sub>OL</sub>	Output Low Voltage	0.95		1.5	0.95		1.5	0.95		1.5	0.95		1.5	V
R <sub>O</sub>	Output Impedance	15		70	15		70	15		70	15		70	Ω
DV <sub>OUT</sub>	Peak-to-Peak Voltage <sup>1</sup>	250	350	470	250	350	470	250	350	470	250	350	470	mV

**AC Characteristics**
**SK1303 AC Electrical Characteristics**

(VCC = +3.0V to +5.5V; VEE = 0V)

Symbol	Characteristic	TA = - 40°C			TA = 0°C			TA = + 25°C			TA = + 85°C			Unit
		Min	Typ	Max	Min	Typ	Max	Min	Typ	Max	Min	Typ	Max	
F <sub>MAX</sub>	Max Toggle Frequency <sup>2</sup>	800			800			800			800			MHz
t <sub>PLH</sub> t <sub>PHL</sub>	Propagation Delay D to Q	450	595	740	450	600	750	470	615	760	500	650	800	ps
t <sub>r</sub> , t <sub>f</sub>	Output Rise/Fall	150	335	520	150	240	330	150	240	330	160	250	340	ps

**Notes:**

- DV<sub>OUT</sub> is obtained as follows: Voltages of Q and Q\* outputs with respect with V<sub>EE</sub> are measured. The absolute difference between the high and the low is equal to DV<sub>OUT</sub>.
- 250 mV minimum output peak-to-peak swing per Max. toggle frequency.

**Application Notes**
**AN1004 - Interfacing Between LVDS and ECL / LVECL / PECL / LVPECL**

**HIGH-PERFORMANCE PRODUCTS**

**Ordering Information**

Ordering Code	Package ID
SK1303D	8-SOIC
SK1303DT	8-SOIC
SK1303MS	8-MSOP
SK1303MST	8-MSOP

The letter “T” stands for tape and reel. For tape and reel information refer to the HPP Part Ordering Information Data Sheet.

**Marking Information**

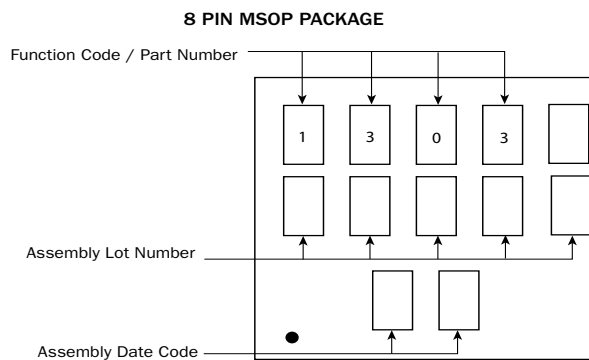
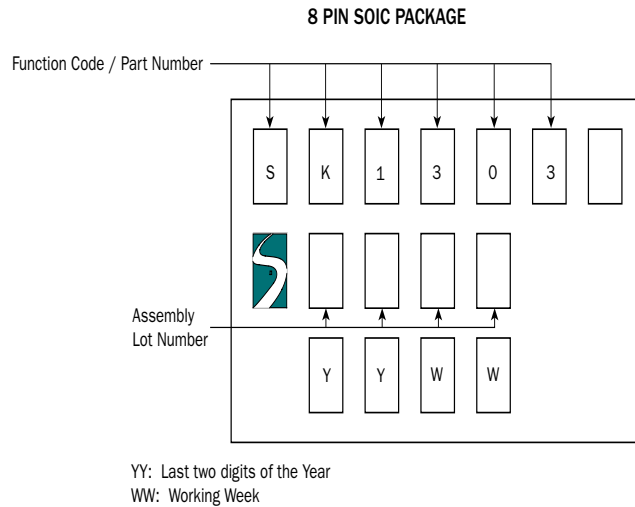

**Contact Information**

<p>Division Headquarters 10021 Willow Creek Road San Diego, CA 92131 Phone: (858) 695-1808 FAX: (858) 695-2633</p>	<p><b>Semtech Corporation</b> <b>High-Performance Products Division</b></p>	<p>Marketing Group 1111 Comstock Street Santa Clara, CA 95054 Phone: (408) 566-8776 FAX: (408) 566-8759</p>
--	---	---