

MAGNACHIP SEMICONDUCTOR LTD.
8-BIT SINGLE-CHIP MICROCONTROLLERS

MC80F0424/0432/0448
MC80C0424/0432/0448

User's Manual (Ver. 0.2)



Version History

Ver 0.2 (MAR, 2005) this book
FLASH memory feature is included.

Ver 0.1 (MAR, 2005)
First release version.

Version 0.2

Published by
MCU Application Team

©2005 MagnaChip Semiconductor Ltd. All right reserved.

Additional information of this manual may be served by MagnaChip semiconductor offices in Korea or Distributors and Representatives.

MagnaChip semiconductor reserves the right to make changes to any information here in at any time without notice.

The information, diagrams and other data in this manual are correct and reliable; however, MagnaChip semiconductor is in no way responsible for any violations of patents or other rights of the third party generated by the use of this manual.

CONTENTS

1. OVERVIEW	1
1.1 Description	1
1.2 Features	1
1.3 Development Tools	2
1.4 Ordering Information	3
2. BLOCK DIAGRAM	4
3. PIN ASSIGNMENT	5
4. PACKAGE DIAGRAM	7
5. PIN FUNCTION	9
5.1 MC80F0424/0432/0448 Pin Description	10
6. PORT STRUCTURES	13
7. ELECTRICAL CHARACTERISTICS	17
7.1 Absolute Maximum Ratings	17
7.2 Recommended Operating Conditions	17
7.3 A/D Converter Characteristics	17
7.4 DC Electrical Characteristics	18
7.5 AC Characteristics	19
7.6 Serial Interface Timing Characteristics	20
7.7 Typical Characteristic Curves	21
8. MEMORY ORGANIZATION	24
8.1 Registers	24
8.2 Program Memory	26
8.3 Data Memory	30
8.4 Addressing Mode	36
9. I/O PORTS	40
10. CLOCK GENERATOR	44
11. BASIC INTERVAL TIMER	46
12. WATCHDOG TIMER	48
13. WATCH TIMER	51
14. TIMER/EVENT COUNTER	52
14.1 8-bit Timer / Counter Mode	56
14.2 16-bit Timer / Counter Mode	62
14.3 8-bit Compare Output (16-bit)	63
14.4 8-bit Capture Mode	64
14.5 16-bit Capture Mode	68
14.6 PWM Mode	71
15. ANALOG TO DIGITAL CONVERTER	75

16. SERIAL INPUT/OUTPUT (SIO)	78
16.1 Transmission/Receiving Timing	79
16.2 The method of Serial I/O	81
16.3 The Method to Test Correct Transmission	81
17. UNIVERSAL ASYNCHRONOUS RECEIVER/TRANSMITTER (UART)	82
17.1 UART Serial Interface Functions	82
17.2 Serial Interface Configuration	83
17.3 Communication operation	85
17.4 Relationship between main clock and baud rate	86
17.5 Communication operation	87
18. BUZZER FUNCTION	88
19. INTERRUPTS	90
19.1 Interrupt Sequence	92
19.2 BRK Interrupt	94
19.3 Shared Interrupt Vector	94
19.4 Multi Interrupt	95
19.5 External Interrupt	96
20. OPERATION MODE	98
20.1 Operation Mode Switching	99
21. POWER SAVING OPERATION	101
21.1 Sleep Mode	101
21.2 Stop Mode	102
21.3 Stop Mode at Internal RC-Oscillated Watchdog Timer Mode	105
21.4 Minimizing Current Consumption	107
22. OSCILLATOR CIRCUIT	109
23. RESET	110
24. POWER FAIL PROCESSOR	111
25. FLASH PROGRAMMING	113
25.1 Lock bit	113
25.2 Power Fail Detection level	113
26. Emulator EVA. Board Setting	114
27. IN-SYSTEM PROGRAMMING (ISP)	117
27.1 Getting Started / Installation	117
27.2 Basic ISP S/W Information	117
27.3 Hardware Conditions to Enter the ISP Mode	119
27.4 Reference ISP Circuit Diagram and MagnaChip Supplied ISP Board	120
INSTRUCTION MAP	i
INSTRUCTION SET	ii
MASK ORDER SHEET	viii

MC80F0424/0432/0448

MC80C0424/0432/0448

CMOS SINGLE-CHIP 8-BIT MICROCONTROLLER WITH 10-BIT A/D CONVERTER AND UART

1. OVERVIEW

1.1 Description

The MC80F0424/0432/0448 is advanced CMOS 8-bit microcontroller with 48K/32K/24K bytes of ROM(FLASH). This is a powerful microcontroller which provides a highly flexible and cost effective solution to many embedded control applications. This provides the following standard features : 24K/32K/48K bytes of ROM(FLASH), 1.5K bytes of RAM, 8/16-bit timer/counter, watchdog timer, watch timer, 10-bit A/D converter, 8-bit Serial Input/Output, UART, 6-bit buzzer driving port, 10-bit PWM output and on-chip oscillator and clock circuitry. It also has 8 high current I/O pins with typical 20mA. In addition, the MC80F0424/0432/0448 supports power saving modes to reduce power consumption.

FLASH MCU	MASK MCU	ROM	RAM	ADC	PWM	I/O PORT	Package
MC80F0424	MC80C0424	24KB	1.5KB	16 channel	2 channel	57 port	64SDIP, 64MQFP 64LQFP
MC80F0432	MC80C0432	32KB	1.5KB				
MC80F0448	MC80C0448	48KB	1.5KB				

1.2 Features

- **24/32K/48K Bytes On-chip ROM**
- **FLASH memory**
 - Endurance : 100 cycles
 - Data retention time : 10 years
- **1.5K Bytes of On-chip Data RAM**
(Included stack memory)
- **Minimum Instruction Execution Time**
 - 333ns at 12MHz (NOP instruction)
- **57 I/O Ports at 64 pin**
- **One 8-bit Basic Interval Timer**
- **Four 8-bit and one 16-bit Timer/Event counter**
(or three 16-bit Timer/Event counter)
- **One Watchdog timer**
- **One Watch timer**
- **Two 10-bit PWM**
- **Three 8-bit Serial Communication Interface**
 - One SIO and two UART
- **One Buzzer Driving port**
 - 488Hz ~ 250kHz@4MHz
- **16 channel 10-bit A/D converter**
- **Four External Interrupt input ports**
- **Fifteen Interrupt sources**
 - Basic Interval Timer(1), External input(4)
 - Timer/Event counter(5), ADC(1)
 - Serial Interface(3), WDT and Watch Timer(1)
- **Built in Noise Immunity Circuit**
 - Noise filter
 - 3-level Power fail detector [3.0V, 2.7V, 2.4V]
- **Power Down Mode**
 - Stop, Sleep, Sub active, Sub sleep mode
- **Wide Operating Voltage Range**
 - 2.7V to 5.5V @ (0.4~4MHz)
 - 4.5V to 5.5V @ (0.4~12MHz)
- **0.4 ~ 12MHz Wide Operating Frequency Range**
- **64SDIP, 64MQFP, 64LQFP type**
- **Operating Temperature : -40°C ~ 85°C**
- **Oscillator Type**
 - Crystal, Ceramic resonator, External clock
- **Sub-clock : 32.768kHz crystal oscillator**

1.3 Development Tools

The MC80F0424/0432/0448 is supported by a full-featured macro assembler, an in-circuit emulator CHOICE-Dr.™ and OTP programmers. There are two different type of programmers such as single type and gang type. For mode detail, Refer to “25. FLASH PROGRAMMING” on page 113. Macro assembler operates under the MS-Windows 95 and upversioned Windows OS. Please contact sales part of MagnaChip semiconductor.

Software	<ul style="list-style-type: none"> - MS-Windows based assembler - MS-Windows based Debugger - HMS800 C compiler
Hardware (Emulator)	<ul style="list-style-type: none"> - CHOICE-Dr. - CHOICE-Dr. EVA 80C0x B/D
FLASH Writer	<ul style="list-style-type: none"> - CHOICE - SIGMA I/II(Single writer) - PGM Plus I/II/III(Single writer) - Standalone GANG4 I/II(Gang writer)



Figure 1-2 PGM-Plus (Single writer)



Figure 1-1 Choice-Dr (Emulator)



Figure 1-3 Standalone GANG4 (Gang writer)

1.4 Ordering Information

	Device name	ROM Size	RAM size	Package
Mask version	MC80C0424K MC80C0424Q MC80C0424L	24K bytes	1.5K bytes	K : 64SDIP Q : 64QFP L : 64LQFP
	MC80C0432K MC80C0432Q MC80C0432L	32K bytes		
	MC80C0448K MC80C0448Q MC80C0448L	48K bytes		
FLASH version	MC80F0424K MC80F0424Q MC80F0424L	24K bytes		
	MC80F0432K MC80F0432Q MC80F0432L	32K bytes		
	MC80F0448K MC80F0448Q MC80F0448L	48K bytes		

Table 1-1 Ordering Information of MC80F0424/0432/0448

2. BLOCK DIAGRAM

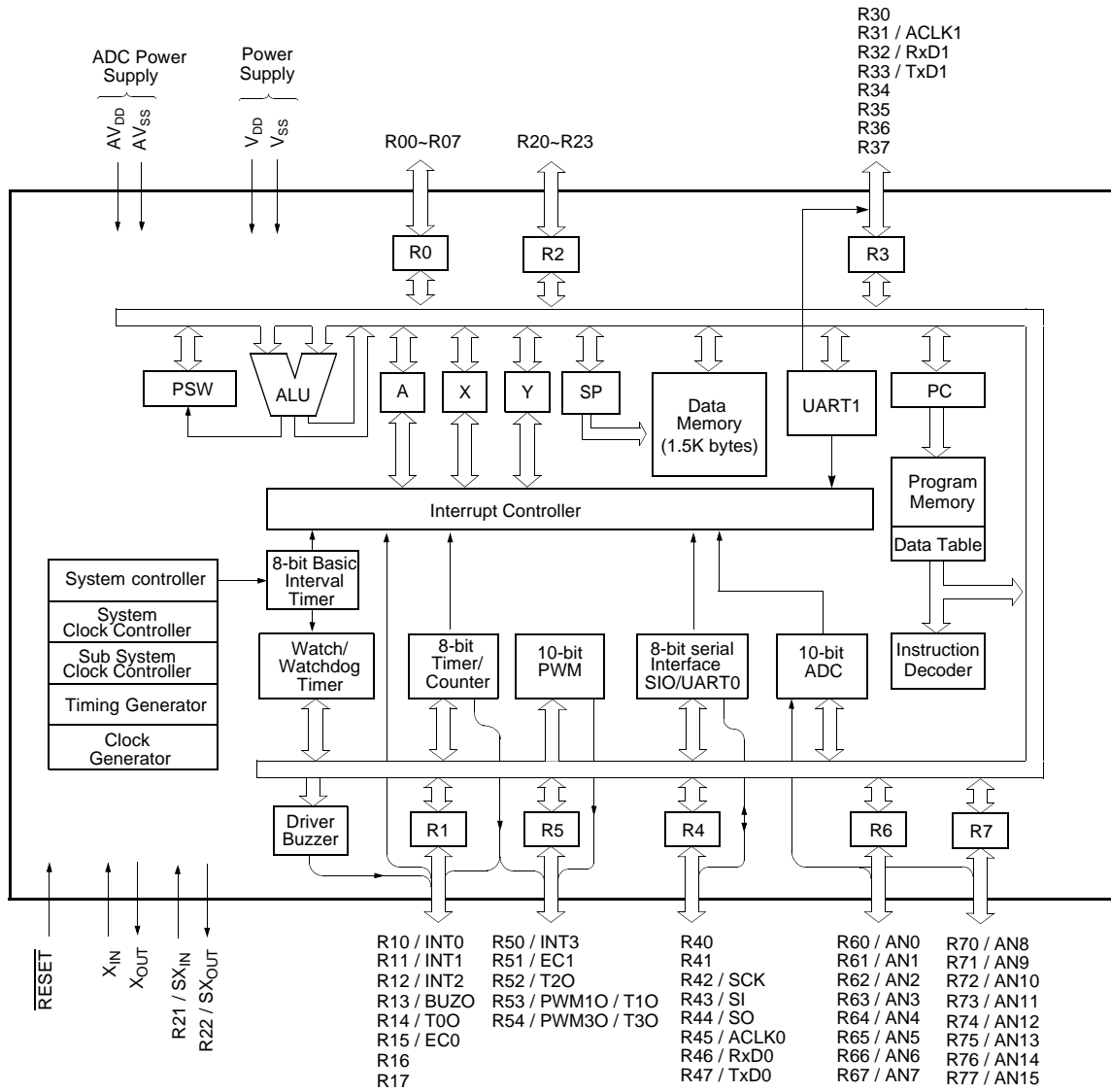

3. PIN ASSIGNMENT

64SDIP
(Top View)

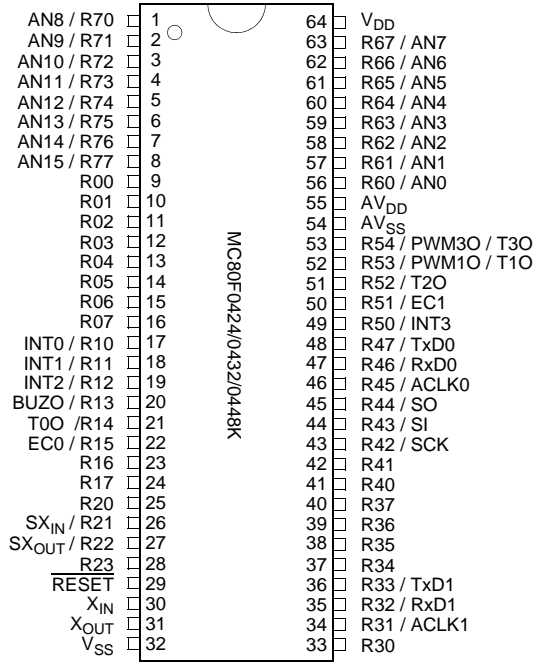

64MQFP
(Top View)

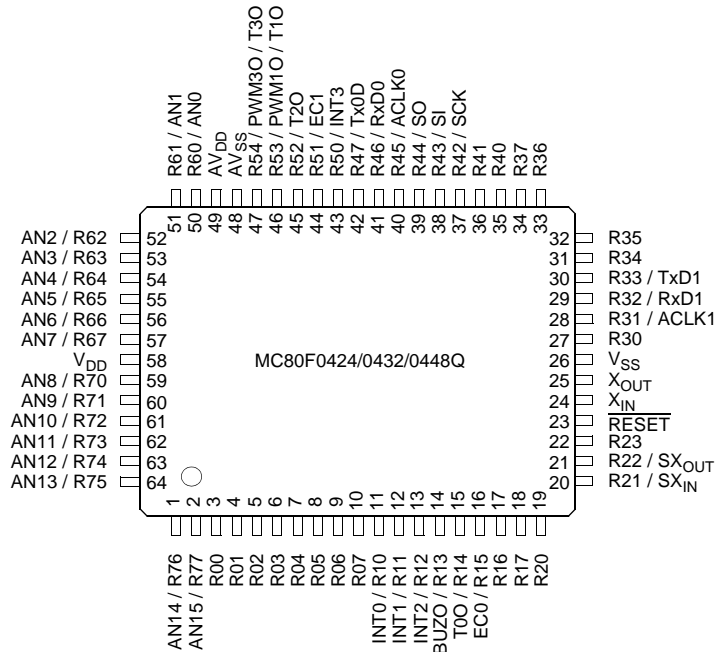

**64LQFP
(Top View)**

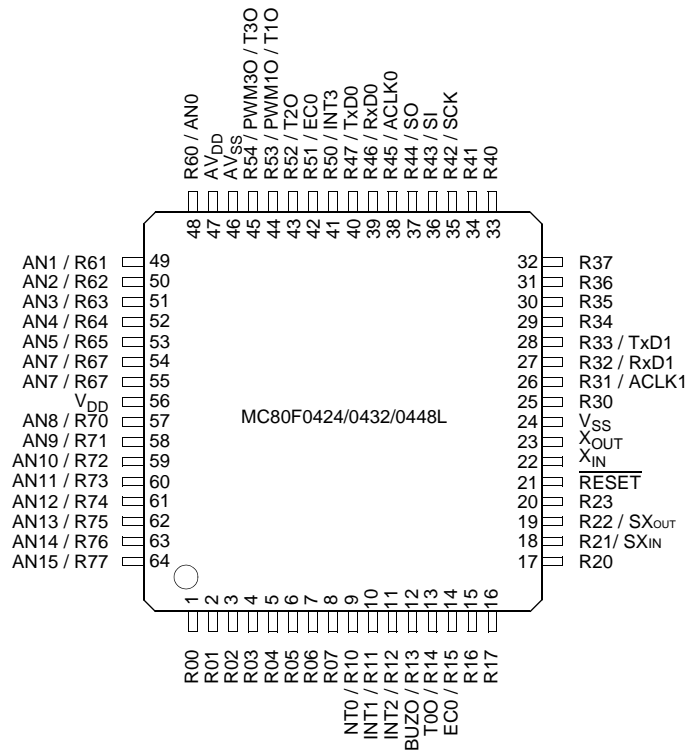

4. PACKAGE DIAGRAM

64SDIP

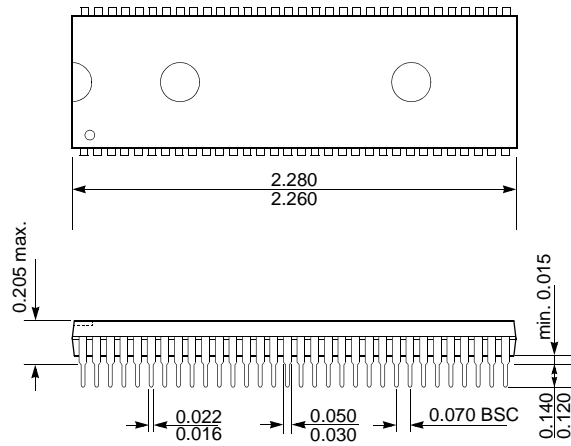

UNIT: INCH

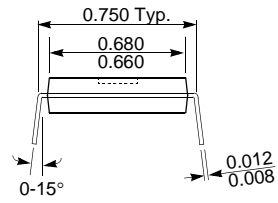

64MQFP

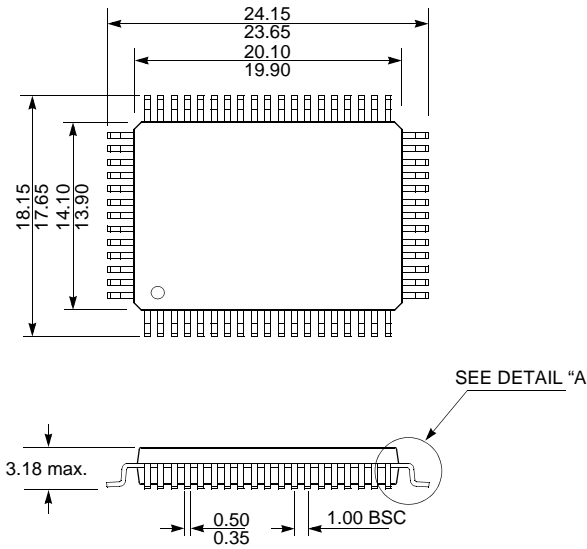

UNIT: MM

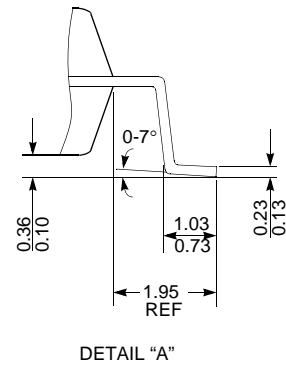

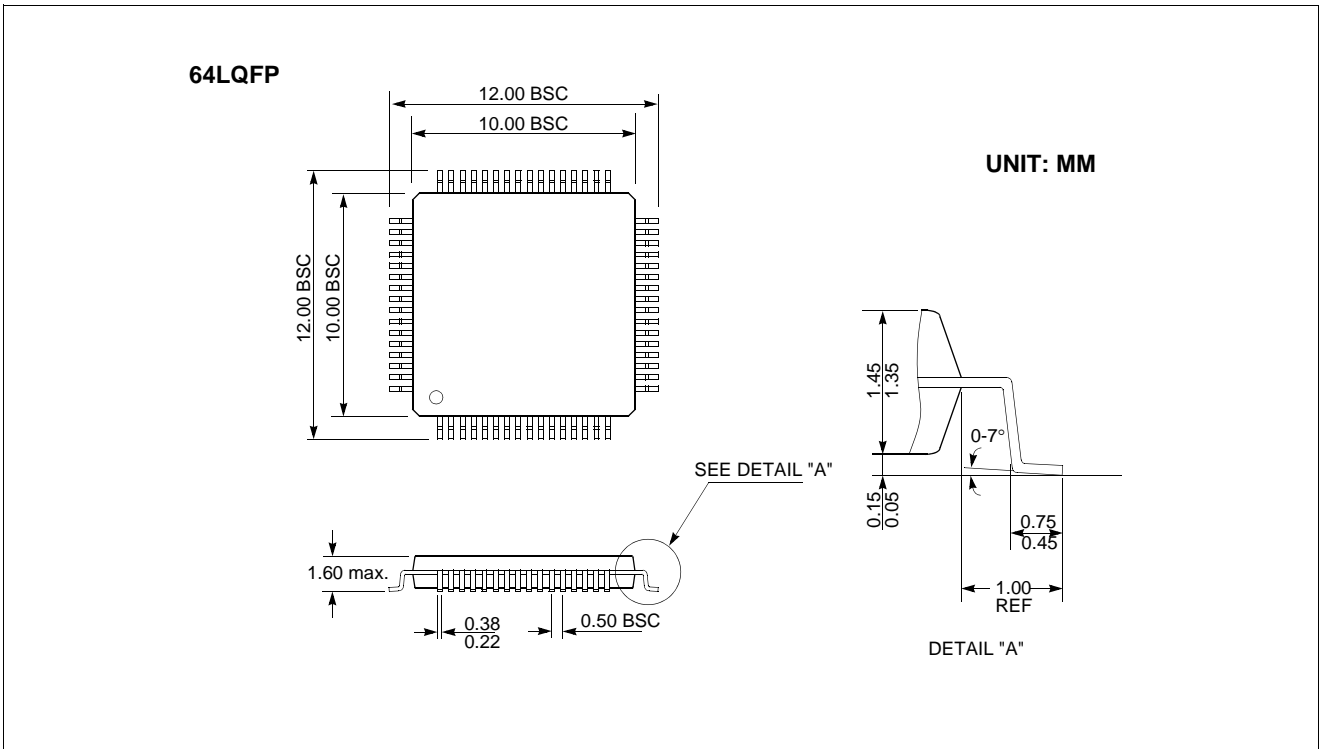

5. PIN FUNCTION

V_{DD}: Supply voltage.

V_{SS}: Circuit ground.

AV_{DD}: Supply voltage to the ladder resistor of ADC circuit.

AV_{SS}: ADC circuit ground.

RESET: Reset the MCU.

X_{IN}: Input to the inverting oscillator amplifier and input to the internal main clock operating circuit.

X_{OUT}: Output from the inverting oscillator amplifier.

R00~R07: R0 is an 8-bit CMOS bidirectional I/O port. R0 pins with 1 or 0 written to the R0 Port Direction Register R0IO can be used as outputs or inputs. The internal pull-up resistor can be connected by using the pull-up selection register 0 (PU0).

R10~R17: R1 is an 8-bit CMOS bidirectional I/O port. R1 pins with 1 or 0 written to the R1 Port Direction Register R1IO can be used as outputs or inputs. The internal pull-up resistor can be connected by using the pull-up selection register 1 (PU1).

In addition, R1 serves the functions of the various following special features such as INT0 (External interrupt 0), INT1 (External interrupt 1), INT2 (External interrupt 2), BUZO (Buzzer driver output), T0O (Timer 0 output), EC0 (Event counter input 0).

R20~R23: R2 is an 4-bit CMOS bidirectional I/O port. R2 pins with 1 or 0 written to the R2 Port Direction Register R2IO can be used as outputs or inputs.

In addition, R2 serves the functions of the various following special features such as SX_{IN} (Sub clock input), SX_{OUT} (Sub clock output).

R30~R37: R3 is an 8-bit CMOS bidirectional I/O port. R3 pins with 1 or 0 written to the R3 Port Direction Register R3IO can be used as outputs or inputs. R3 operates as the high current output

port with typical 20mA at low level output.

In addition, R3 serves the functions of the various following special features such as ACLK1 (UART1 Asynchronous serial clock input), RxD1 (UART1 data input), TxD1 (UART1 data output)

R40~R47: R4 is an 8-bit CMOS bidirectional I/O port. R4 pins with 1 or 0 written to the R4 Port Direction Register R4IO can be used as outputs or inputs. The internal pull-up resistor can be connected by using the pull-up selection register 4 (PU4).

In addition, R4 serves the functions of the various following special features such as SCK (Serial clock), SI (Serial data input), SO (Serial data output), ACLK0 (UART0 Asynchronous serial clock input), RxD0 (UART0 data input), TxD0 (UART0 data output).

R50~R54: R5 is an 5-bit CMOS bidirectional I/O port. R5 pins with 1 or 0 written to the R5 Port Direction Register R5IO can be used as outputs or inputs.

In addition, R5 serves the functions of the various following special features such as INT3 (External interrupt 3), EC1 (Event counter input 1), T2O (Timer 2 output), PWM1O (PWM 1 output) / T1O (Timer 1 compare output), PWM3O (PWM 3 output) / T3O (Timer 3 compare output).

R60~R67: R6 is an 8-bit CMOS bidirectional I/O port. R6 pins with 1 or 0 written to the R6 Port Direction Register R6IO can be used as outputs or inputs.

In addition, R6 serves the functions of the ADC analog input port AN[7:0].

R70~R77: R7 is an 8-bit CMOS bidirectional I/O port. R7 pins with 1 or 0 written to the R7 Port Direction Register R7IO can be used as outputs or inputs. The internal pull-up resistor can be connected by using the pull-up selection register 7 (PU7).

In addition, R7 serves the functions of the ADC analog input port AN[15:8].

5.1 MC80F0424/0432/0448 Pin Description

5.1.1 MC80F0424/0432/0448 Pin Description

PIN NAME	In/Out	Function	Initial state	Alternate Function
R00~R07	I/O	Port 0. 8-bit I/O port. Can be set as input or output mode in 1-bit units. Internal pull-up resistor PU0 can be used via software.	Input	-
R10	I/O	Port 1. 8-bit I/O port. Can be set as input or output mode in 1-bit units. Internal pull-up resistor PU1 can be used via software.	Input	INT0
R11				INT1
R12				INT2
R13				BUZO
R14				T0O
R15				EC0
R16				-
R17				-
R20	I/O	Port 2. 4-bit I/O port. Can be set in input or output mode in 1-bit units. Crystal(32.768KHz) connecting pins(R21,R22)	Input	-
R21				SX _{IN}
R22				SX _{OUT}
R23				-
P30	I/O	Port 3. 8-bit I/O port. Can be set in input or output mode in 1-bit units. Operates as high current output port with typical 20mA at low level output.	Input	ACLK1
P31				RxD1
P32				TxD1
P33				
P34				
P35				
P36				
P37				-
R40	I/O	Port 4. 8-bit I/O port. Can be set in input or output mode in 1-bit units. Internal pull-up resistor PU4 can be used via software.	Input	-
R41				-
R42				SCK
R43				SI
R44				SO
R45				ACLK0
R46				RxD0
R47				TxD0
R50	I/O	Port 5. 5-bit I/O port. Can be set in input or output mode in 1-bit units.	Input	INT3
R51				EC1
R52				T2O
R53				PWM10/T10
R54				PWM30/T30

Table 5-1 MC80F0424/0432/0448 Pin Description

PIN NAME	In/Out	Function	Initial state	Alternate Function
R60~R67	I/O	Port 6. 8-bit I/O port. Can be set in input or output mode in 1-bit units.	Input	AN0~AN7
R70~R77	I/O	Port 7. 8-bit I/O port. Can be set in input or output mode in 1-bit units. Internal pull-up resistor PU7 can be used via software.	Input	AN8~AN15
$\overline{\text{RESET}}$	I	System reset input.	Input	-
X_{IN}	I	Crystal connection for main system clock oscillation.	Input	-
X_{OUT}	O		Output	-
AV_{DD}	-	Analog power/reference voltage input to A/D converter. Set the same potential as VDD.	-	-
AV_{SS}	-	Ground potential for A/D converter. Set the same potential as V_{SS} .	-	-
V_{DD}	-	Positive power supply.	-	-
V_{SS}	-	Ground potential.	-	-

Table 5-1 MC80F0424/0432/0448 Pin Description

5.1.2 MC80F0424/0432/0448 Alternate Function Pin Description

PIN NAME	In/Out	Function	Initial state	Shared Pin
INT0	I	Valid edges(rising, falling, or both rising and falling) can be specified. External Interrupt request Input.	Input	R10
INT1				R11
INT2				R12
INT3				R50
BUZO	O	Buzzer Output	Input	R13
T0O	O	Timer0 Output	Input	R14
T2O	O	Timer2 Output	Input	R52
EC0	I	Timer0 Event Counter Input	Input	R15
EC1	I	Timer2 Event Counter Input	Input	R51
SX _{IN}	I	Resonator connecting pins (32.768KHz)	Input	R21
SX _{OUT}	O		Input	R22
ACLK1	I	UART1 Asynchronous serial interface serial clock input.	Input	R31
RxD1	I	UART1 Asynchronous serial interface serial data input.	Input	R32
TxD1	O	UART1 Asynchronous serial interface serial data output.	Input	R33
SCK	I/O	Serial clock input/output of serial interface.	Input	R42
SI	I	Serial data input of serial interface.	Input	R43
SO	O	Serial data output of serial interface.	Input	R44
ACLK0	I	UART0 Asynchronous serial interface serial clock input.	Input	R45
RxD0	I	UART0 Asynchronous serial interface serial data input.	Input	R46
TxD0	O	UART0 Asynchronous serial interface serial data output.	Input	R47
PWM1O/T1O	O	Timer1 PWM Output / Timer 1 Compare Output	Input	R53
PWM3O/T3O	O	Timer3 PWM Output / Timer 1 Compare Output	Input	R54
AN0~AN7	I	Analog input Channel 0 ~ 7 for A/D converter.	Input	R60~R67
AN8~AN15	I	Analog input Channel 8 ~ 15 for A/D converter.	Input	R70~R77

Table 5-2 MC80F0424/0432/0448 Alternate Function Pin Description

6. PORT STRUCTURES

R00~R07, R16, R17, R40, R41

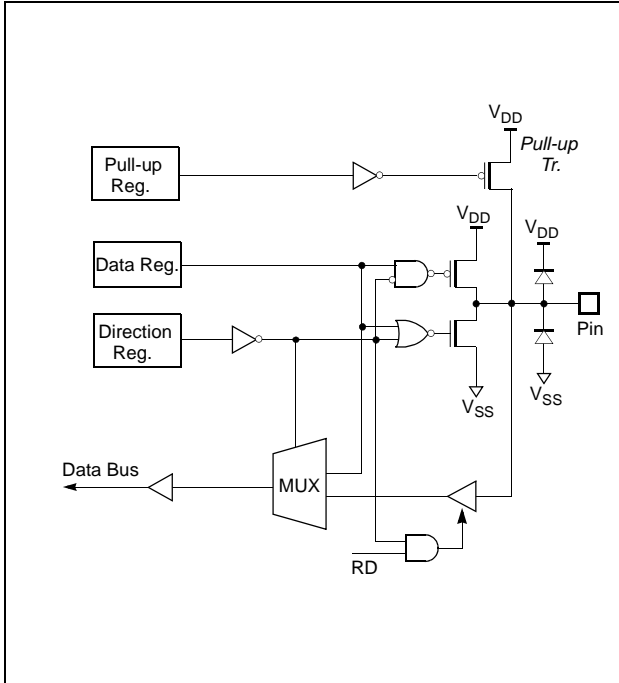

R50(INT3),R51(EC1)

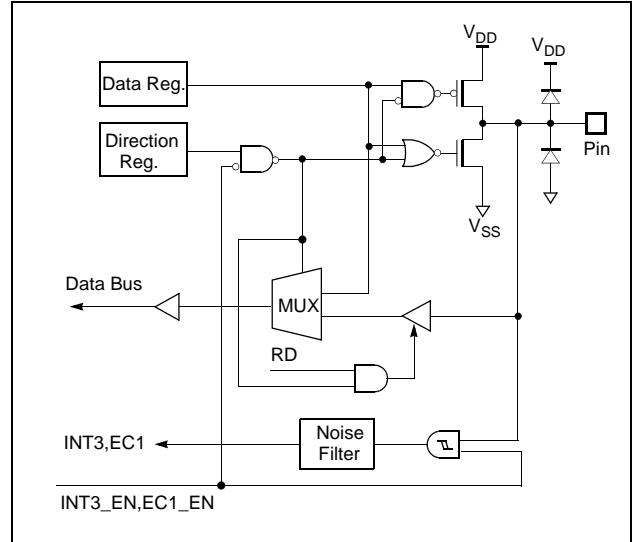

R10(INT0), R11(INT1), R12(INT2), R15(EC0),
R43(SI),R45(ACLK0),R46(RxD0)

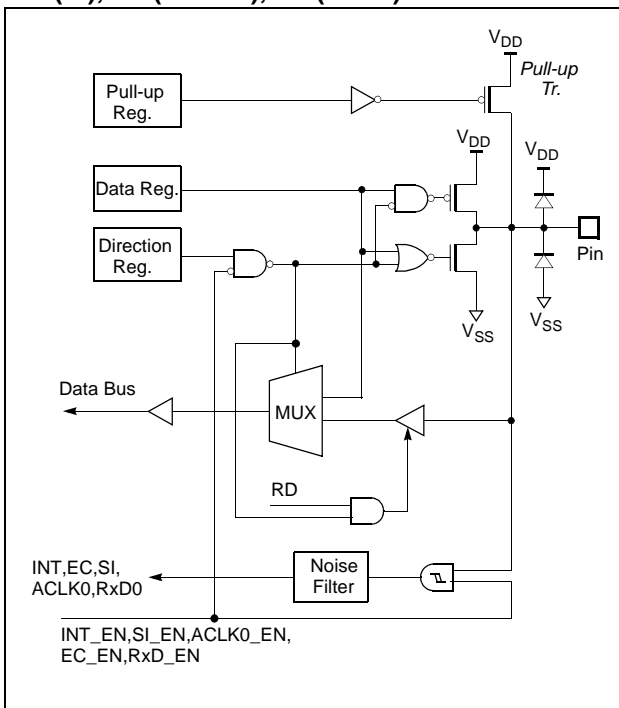

R33(TxD1)

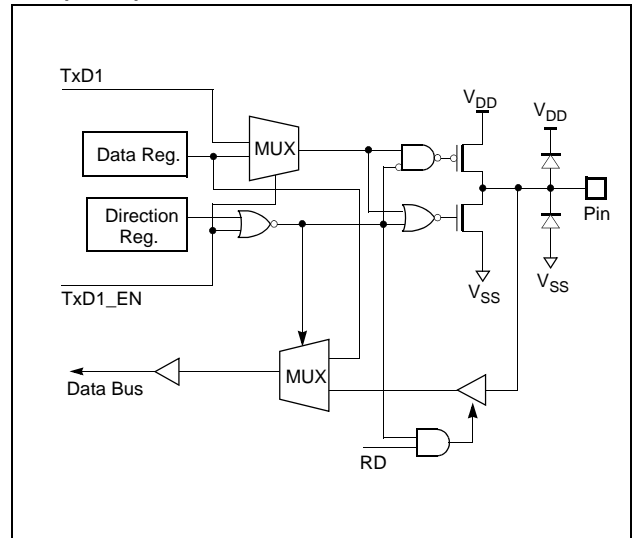

R31(ACLK1), R32(RxD1)

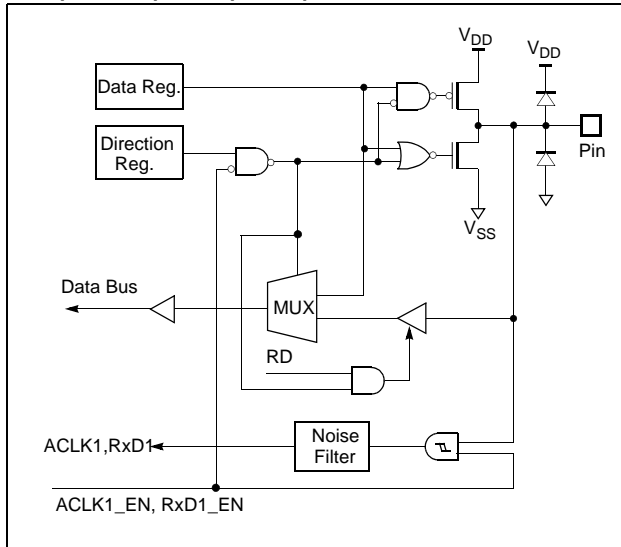

R52(T2O), R53(PWM1O), R54(PWM3O)

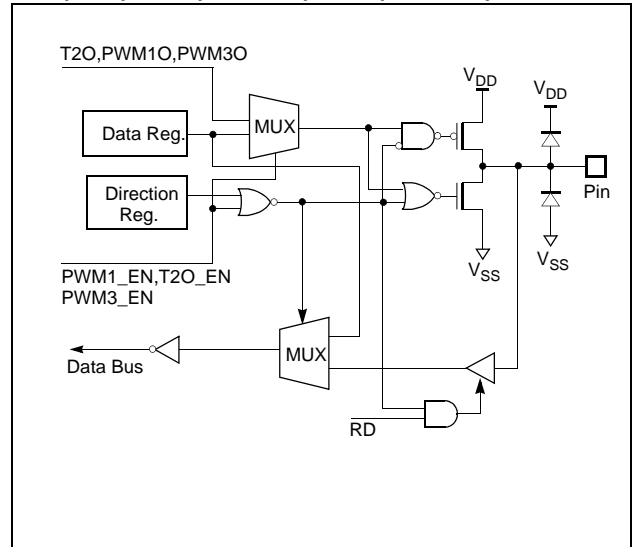

R13(BUZO), R14(T0O), R47(TxD0)

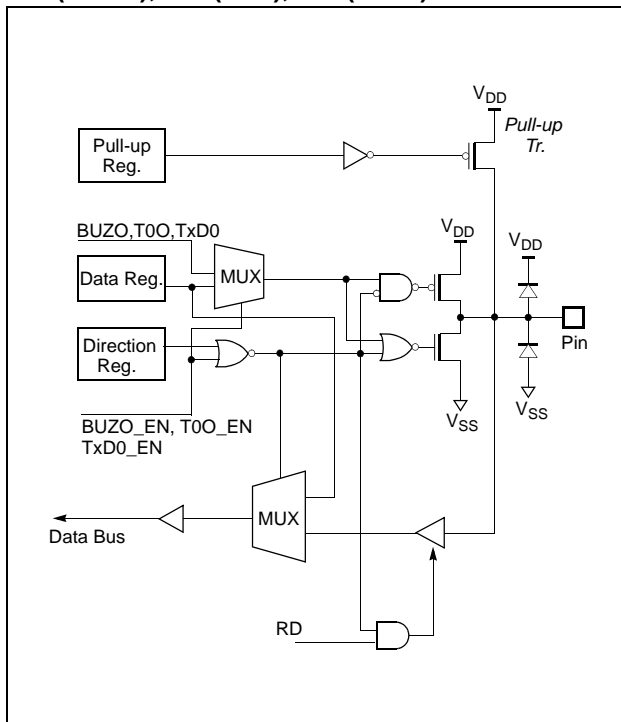

R20, R23, R30-R37

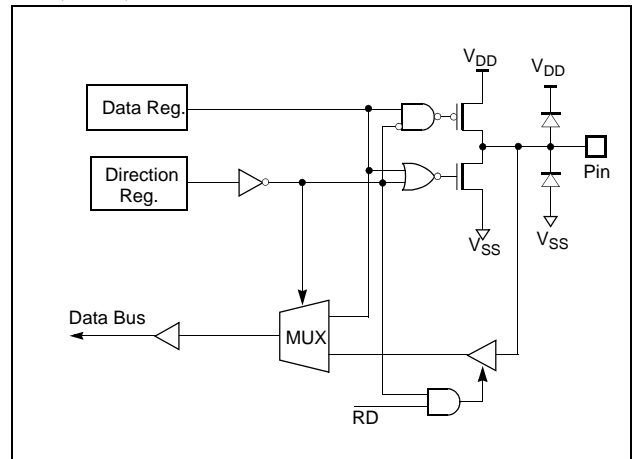

R42(SCK)

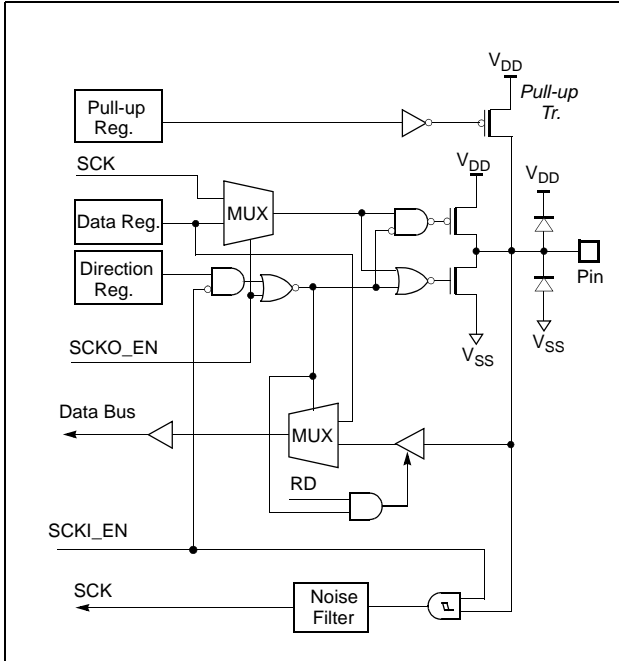

R60~R67(AN0~AN7)

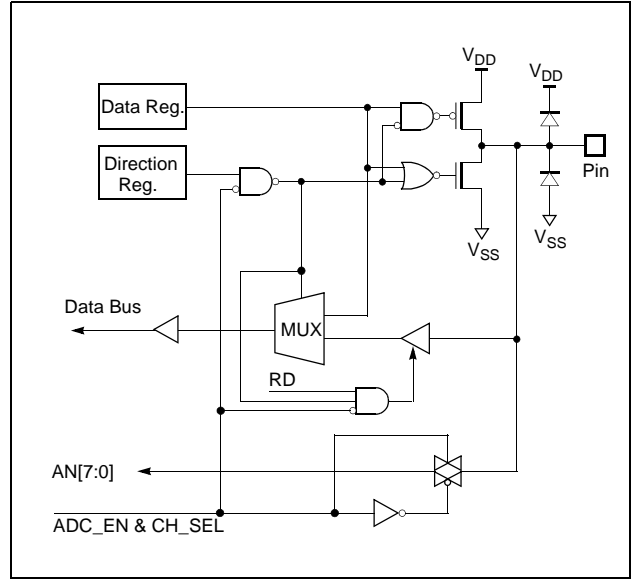

R44(SO, IOSWIN(SI))

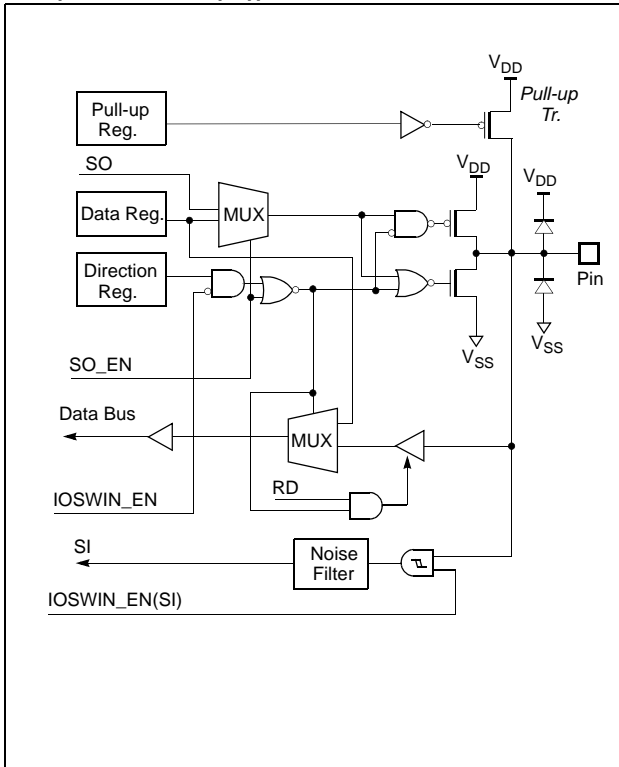

R70~R77(AN8~AN15)

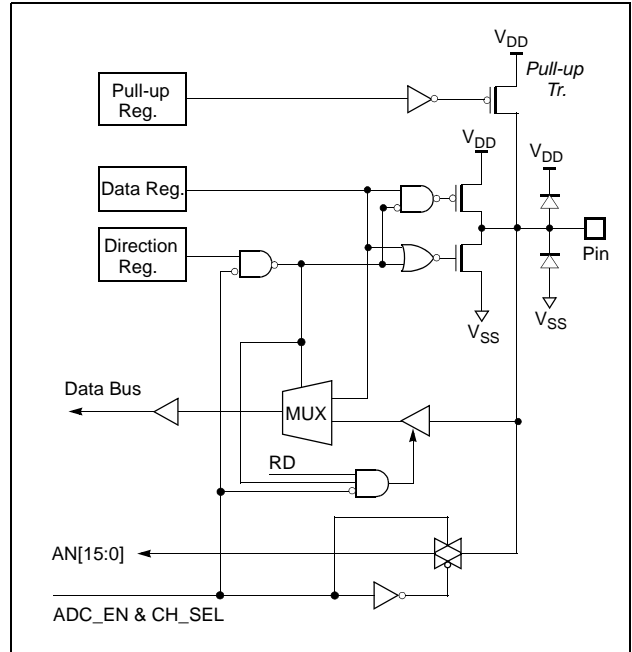

RESET

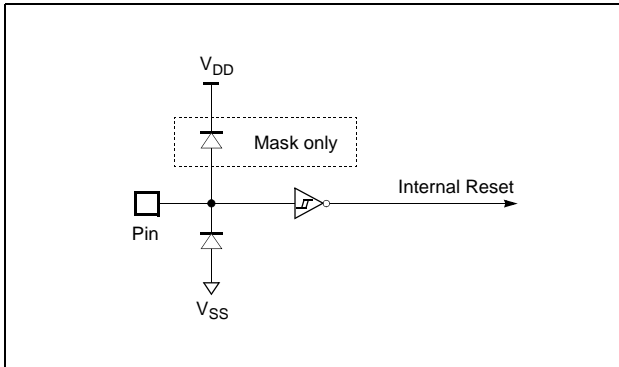

X_{IN}, X_{OUT}

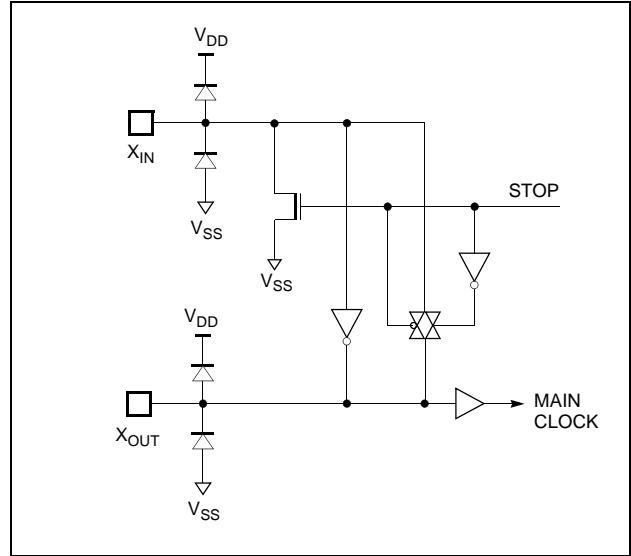

R21(SX_{IN}), R22(SX_{OUT})

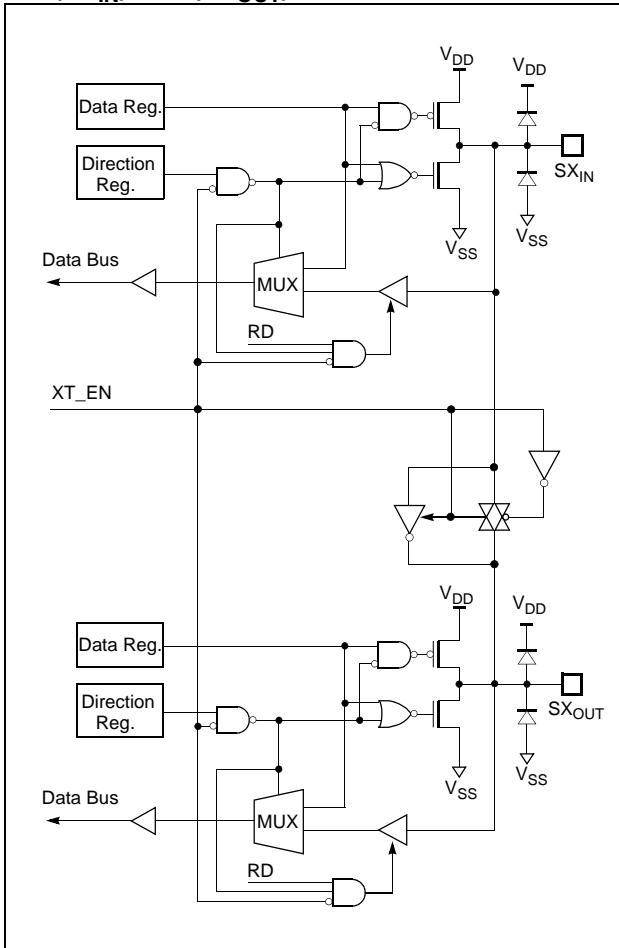

7. ELECTRICAL CHARACTERISTICS

7.1 Absolute Maximum Ratings

Supply voltage.....	-0.3 to +6.5 V
Storage Temperature	-40 to +125 °C
Voltage on any pin with respect to Ground (V_{SS})	-0.3 to $V_{DD}+0.3V$
Maximum current out of V_{SS} pin.....	200 mA
Maximum current into V_{DD} pin.....	100 mA
Maximum current sunk by (I_{OL} per I/O Pin)	20 mA
Maximum output current sourced by (I_{OH} per I/O Pin)	10 mA

Maximum current (ΣI_{OL})	160 mA
Maximum current (ΣI_{OH}).....	80 mA

Note: Stresses above those listed under “Absolute Maximum Ratings” may cause permanent damage to the device. This is a stress rating only and functional operation of the device at any other conditions above those indicated in the operational sections of this specification is not implied. Exposure to absolute maximum rating conditions for extended periods may affect device reliability.

7.2 Recommended Operating Conditions

Parameter	Symbol	Condition	Specifications		Unit
			Min.	Max.	
Supply Voltage	V_{DD}	$f_{XIN}=0.4\sim 12MHz$ $f_{XIN}=0.4\sim 4MHz$	4.5 2.7	5.5 5.5	V
Operating Frequency	f_{XIN}	$V_{DD}=4.5\sim 5.5V$ $V_{DD}=2.7\sim 5.5V$	0.4 0.4	12 4	MHz
Operating Temperature	T_{OPR}		-40	85	°C

7.3 A/D Converter Characteristics

($T_a=-40\sim 85^\circ C$, $V_{SS}=0V$, $V_{DD}=2.7\sim 5.5V$ @Conversion Clock of 1MHz)

Parameter	Symbol	Conditions	Min.	Typ.	Max.	Unit
Resolution		-	-	± 10	-	BIT
Overall Accuracy	N_{ACC}	-	-	-	± 3	LSB
Non Linearity Error	N_{NLE}	-	-	-	± 3	LSB
Differential Non Linearity Error	N_{DNLE}	-	-	-	± 3	LSB
Full Scale Error	N_{FSE}	-	-	-	± 3	LSB
Zero Offset Error	N_{ZOE}	-	-	-	± 3	LSB
Gain Error	N_{NLE}	-	-	-	± 3	LSB
Conversion Time	T_{CONV}	f_{XIN}	13	-	-	μS
Analog Input Voltage	V_{AIN}	-	AV_{SS}	-	AV_{DD}	V
Analog Power Supply	AV_{DD}	-	-	-	V_{DD}	V
Analog Ground	AV_{SS}	-	V_{SS}	-	$V_{SS}+0.3$	V
Analog Block Current	I_{AVDD}	$AV_{DD}=V_{DD}=5.12V$	-	2.5	3	mA

7.4 DC Electrical Characteristics

($T_A = -40 \sim 85^\circ\text{C}$, $V_{DD} = 5.0\text{V} \pm 10\%$, $V_{SS} = 0\text{V}$, $f_{XIN} = 8\text{MHz}$)

Parameter	Symbol	Pin/Condition	Min.	Typ.	Max.	Unit
Input High Voltage	V_{IH1}	INT0, INT1, INT2, INT3, EC0, EC1, SI, SCK, <u>ACLK0</u> , RxD0, <u>ACLK1</u> , RxD1, <u>RESET</u>	$0.8V_{DD}$	-	$V_{DD} + 0.3$	V
	V_{IH2}	R0, R1, R2, R3, R4, R5, R6, R7	$0.7V_{DD}$	-	$V_{DD} + 0.3$	V
	V_{IH3}	X_{IN} , SX_{IN}	$0.8V_{DD}$	-	$V_{DD} + 0.3$	V
Input Low Voltage	V_{IL1}	INT0, INT1, INT2, INT3, EC0, EC1, SI, SCK, <u>ACLK0</u> , RxD0, <u>ACLK1</u> , RxD1, <u>RESET</u>	-0.3	-	$0.2V_{DD}$	V
	V_{IL2}	R0, R1, R2, R3, R4, R5, R6, R7	-0.3	-	$0.3V_{DD}$	V
	V_{IL3}	X_{IN} , SX_{IN}	-0.3	-	$0.2V_{DD}$	V
Output High Voltage	V_{OH1}	R0, R1, R2, R3, R4, R5, R6, R7 ($I_{OH} = -0.7\text{mA}$)	$V_{DD} - 0.4$	-	-	V
	V_{OH2}	X_{OUT} ($I_{OH} = -50\mu\text{A}$)	$V_{DD} - 0.5$	-	-	V
	V_{OH3}	SX_{OUT} ($I_{OH} = -5\mu\text{A}$)	$V_{DD} - 0.5$	-	-	V
Output Low Voltage	V_{OL1}	R0, R1, R2, R3, R4, R5, R6, R7 ($I_{OL} = 1.6\text{mA}$)	-	-	0.4	V
	V_{OL2}	X_{OUT} ($I_{OL} = 50\mu\text{A}$)	-	-	0.5	V
	V_{OL3}	SX_{OUT} ($I_{OL} = 5\mu\text{A}$)	-	-	0.5	V
High Current	I_{OL}	R3 ($V_{OL} = 1\text{V}$)	-	-	20	mA
Input High Leakage Current	I_{IH}	R0, R1, R2, R3, R4, R5, R6, R7	-	-	1	μA
Input Low Leakage Current	I_{IL}	R0, R1, R2, R3, R4, R5, R6, R7	-1	-	-	μA
Pull-up Resistor	RPU	R0, R1, R4, R7	10	-	100	$\text{k}\Omega$
OSC Feedback Resistor	R_X	X_{IN} , X_{OUT}	0.45	-	4.5	$\text{M}\Omega$
	R_{SX}	SX_{IN} , SX_{OUT}	8	-	18	$\text{M}\Omega$
Internal RC WDT Period (RCWDT)	I_{IL}	$V_{DD} = 4.5\text{V}$	33	-	100	μs
Hysteresis	V_T	INT0, INT1, INT2, INT3, EC0, EC1, SI, SCK, <u>ACLK</u> , RxD	0.3	-	0.8	V
Power Fail Detect Voltage	V_{PFD}		2.2	2.7	3.2	V
			2.5	3.0	3.5	V
			1.9	2.4	2.9	V
Power Supply Current	I_{DD1}	Active Mode, $X_{IN} = 8\text{MHz}$	-	-	15	mA
	I_{DD2}	Sub_Active Mode, $SX_{IN} = 0.32\text{MHz}$	-	-	160	μA
	I_{SLEEP1}	Sleep Mode, $X_{IN} = 8\text{MHz}$	-	-	6	mA
	I_{SLEEP2}	Sub_Sleep Mode, $SX_{IN} = 0.32\text{MHz}$	-	-	20	μA
	I_{STOP}	Stop Mode, Oscillator Stop, $X_{IN} = 4\text{MHz}$	-	-	5	μA

7.5 AC Characteristics

($T_A = -40 \sim 85^\circ\text{C}$, $V_{DD} = 5\text{V} \pm 10\%$, $V_{SS} = 0\text{V}$)

Parameter	Symbol	Pins	Specifications			Unit
			Min.	Typ.	Max.	
Operating Frequency	f_{XIN}	X_{IN}	0.4	-	12	MHz
System Clock Cycle Time	t_{SYS}	-	166	-	5000	nS
Oscillation Stabilizing Time (4MHz)	t_{ST}	X_{IN}, X_{OUT}	-	-	20	mS
External Clock Pulse Width	t_{CPW}	X_{IN}	35	-	-	nS
External Clock Transition Time	t_{RCP}, t_{FCP}	X_{IN}	-	-	20	nS
Interrupt Pulse Width	t_{IW}	INT0, INT1, INT2, INT3	2	-	-	t_{SYS}
RESET Input Width	t_{RST}	RESET	8	-	-	t_{SYS}
Event Counter Input Pulse Width	t_{ECW}	EC0, EC1	2	-	-	t_{SYS}
Event Counter Transition Time	t_{REC}, t_{FEC}	EC0, EC1	-	-	20	nS

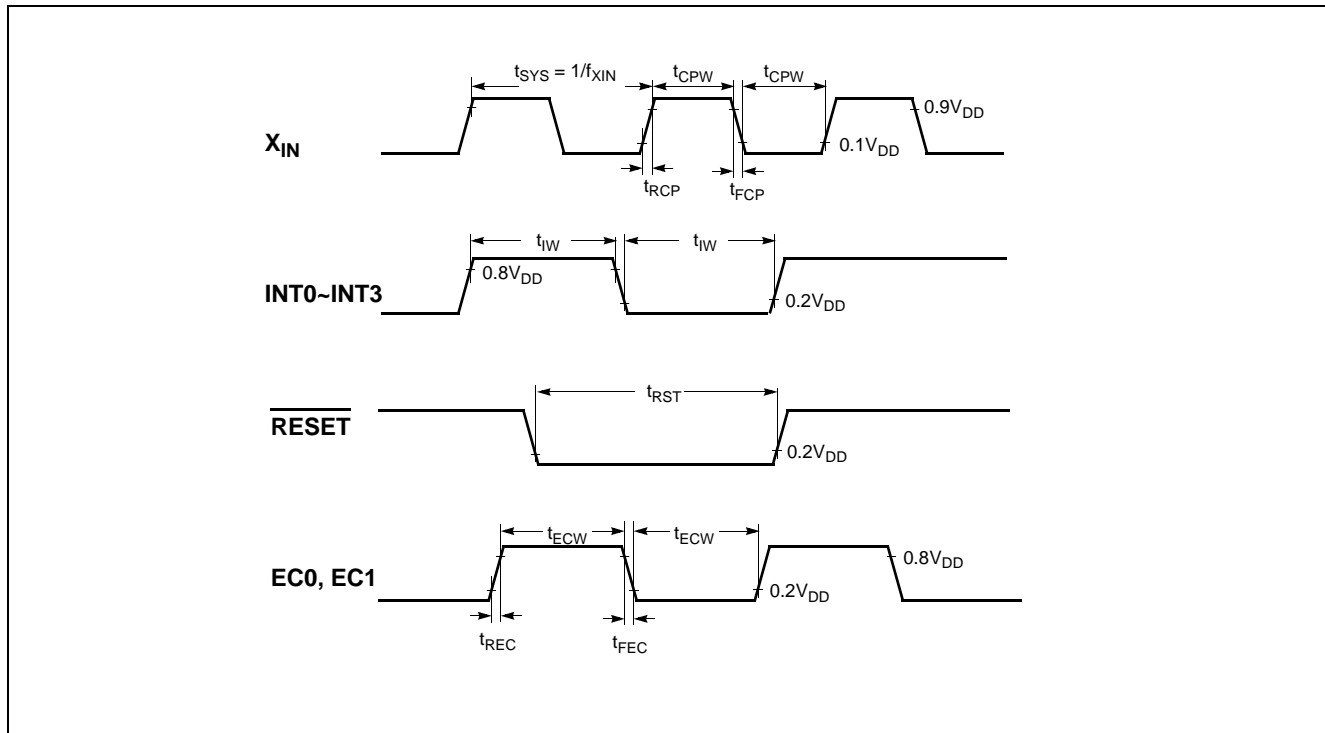

Figure 7-1 Timing Chart

7.6 Serial Interface Timing Characteristics

($T_A = -40 \sim +85^\circ\text{C}$, $V_{DD} = 5V \pm 10\%$, $V_{SS} = 0V$, $f_{XIN} = 8\text{MHz}$)

Parameter	Symbol	Pins	Specifications			Unit
			Min.	Typ.	Max.	
Serial Input Clock Pulse	t_{SCYC}	SCK	$2t_{SYS}+200$	-	-	nS
Serial Input Clock Pulse Width	t_{SCKW}	SCK	$t_{SYS}+70$	-	-	nS
Serial Input Clock Pulse Transition Time	t_{FSCK} t_{RSCK}	SCK	-	-	30	nS
Serial Input Pulse Transition Time	t_{FSIN} t_{RSIN}	SI	-	-	30	nS
Serial Input Setup Time (External SCK)	t_{SUS}	SI	100	-	-	nS
Serial Input Setup Time (Internal SCK)	t_{SUS}	SI	200	-	-	nS
Serial Input Hold Time	t_{HS}	SI	$t_{SYS}+70$	-	-	nS
Serial Output Clock Cycle Time	t_{SCYC}	SCK	$4t_{SYS}$	-	$16t_{SYS}$	nS
Serial Output Clock Pulse Width	t_{SCKW}	SCK	$t_{SYS}-30$	-	-	nS
Serial Output Clock Pulse Transition Time	t_{FSCK} t_{RSCK}	SCK	-	-	30	nS
Serial Output Delay Time	s_{OUT}	SO	-	-	100	nS

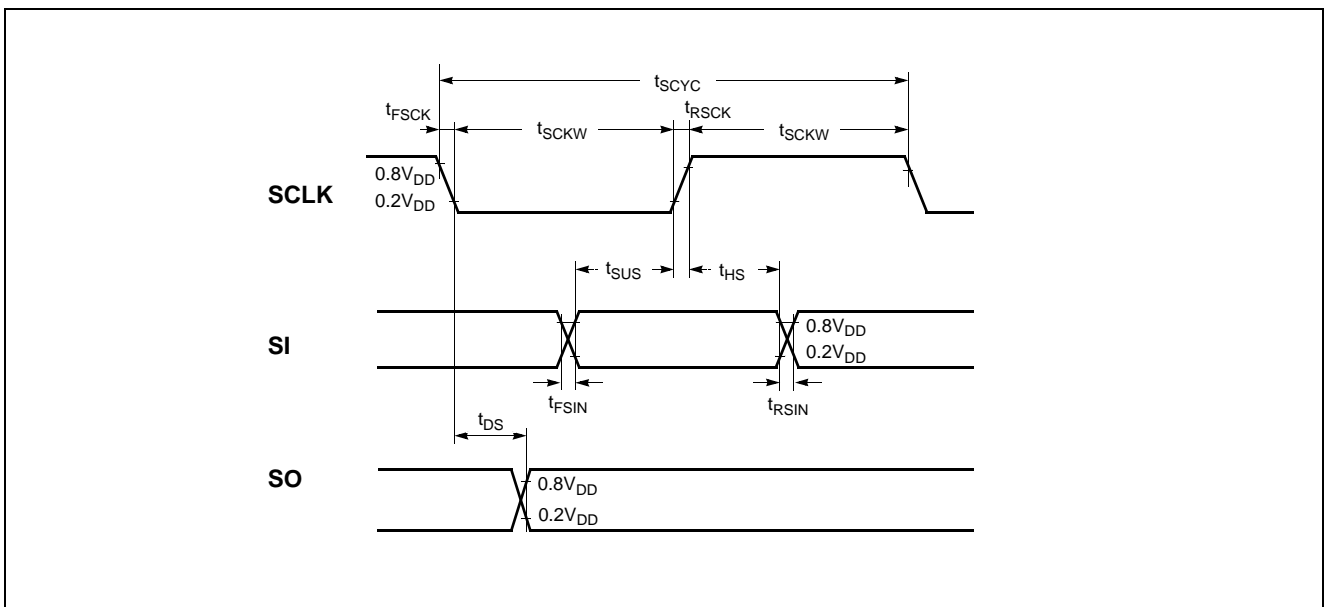

Figure 7-2 Serial I/O Timing Chart

7.7 Typical Characteristic Curves

This graphs and tables provided in this section are for design guidance only and are not tested or guaranteed.

In some graphs or tables the data presented are outside specified operating range (e.g. outside specified V_{DD} range). This is for information only and devices are guaranteed to operate properly only within the specified range.

The data presented in this section is a statistical summary of data collected on units from different lots over a period of time. “Typical” represents the mean of the distribution while “max” or “min” represents (mean + 3σ) and (mean - 3σ) respectively where σ is standard deviation

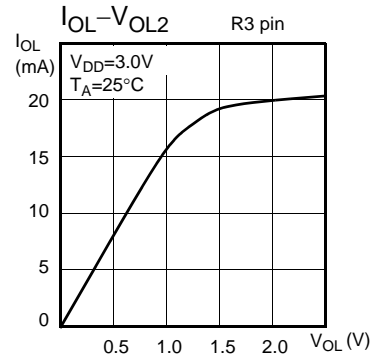
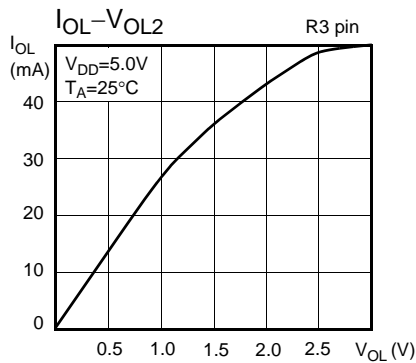
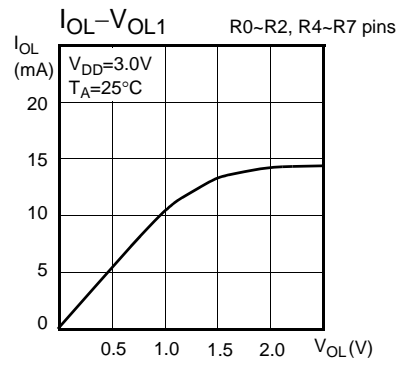
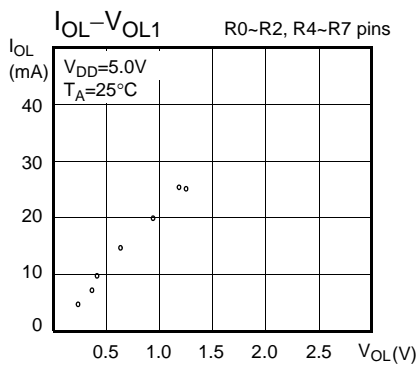
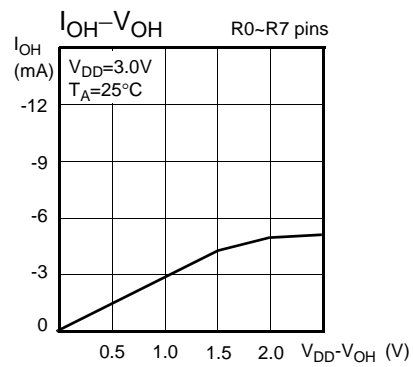
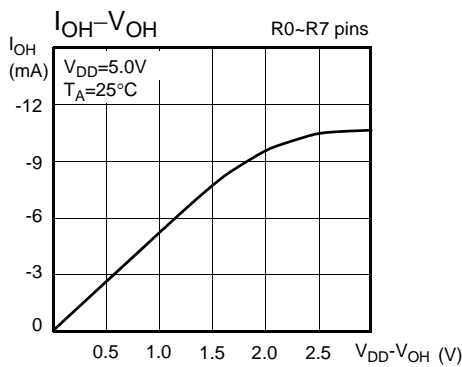

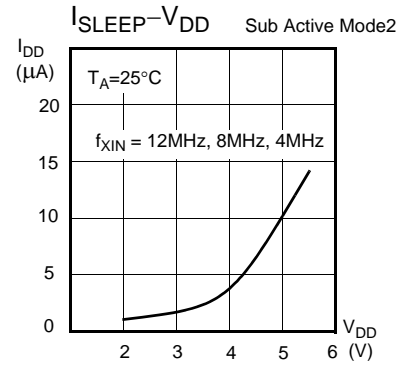
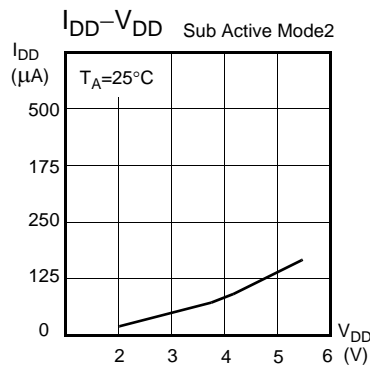
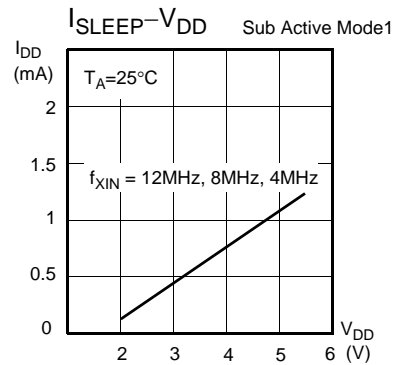
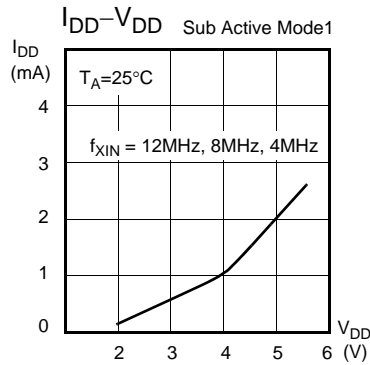
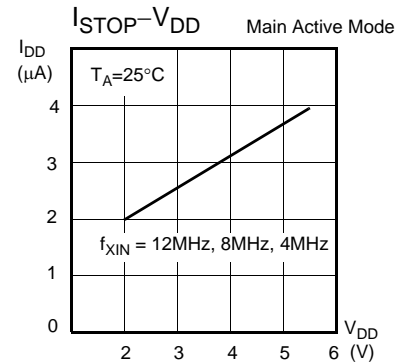
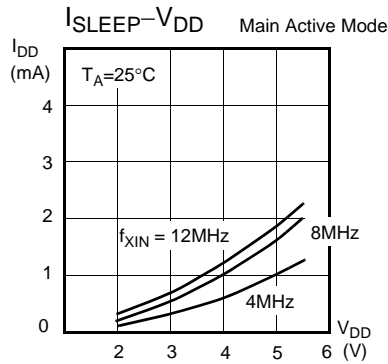
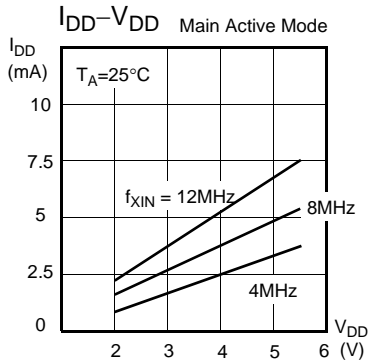

- * Main Active mode : System clock(Main)
- * Sub Active mode1 : System clock(Sub) (at main clock ON, sub clock ON)
- * Sub Active mode2 : System clock(Sub) (at main clock OFF, sub clock ON)

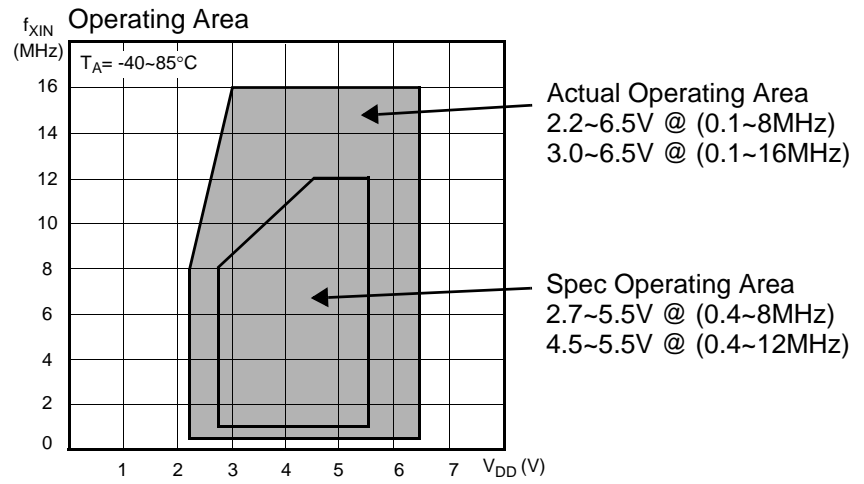

8. MEMORY ORGANIZATION

The MC80F0424/0432/0448 has separate address spaces for Program memory and Data Memory. Program memory can only be read, not written to. It can be up to 48K bytes of Program memo-

ry. Data memory can be read and written to up to 1024 bytes including the stack area.

8.1 Registers

This device has six registers that are the Program Counter (PC), a Accumulator (A), two index registers (X, Y), the Stack Pointer (SP), and the Program Status Word (PSW). The Program Counter consists of 16-bit register.

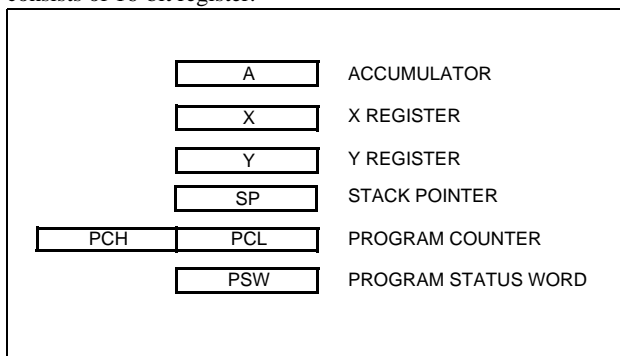

Figure 8-1 Configuration of Registers

Accumulator: The Accumulator is the 8-bit general purpose register, used for data operation such as transfer, temporary saving, and conditional judgement, etc.

The Accumulator can be used as a 16-bit register with Y Register as shown below.

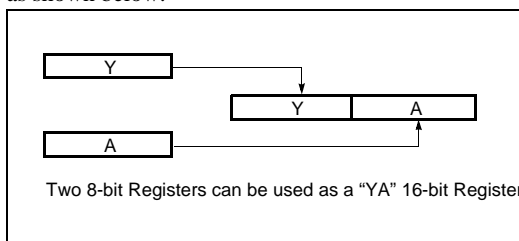

Figure 8-2 Configuration of YA 16-bit Register

X, Y Registers: In the addressing mode which uses these index registers, the register contents are added to the specified address, which becomes the actual address. These modes are extremely effective for referencing subroutine tables and memory tables. The index registers also have increment, decrement, comparison and data transfer functions, and they can be used as simple accumulators.

Stack Pointer: The Stack Pointer is an 8-bit register used for occurrence interrupts and calling out subroutines. Stack Pointer identifies the location in the stack to be accessed (save or restore). Generally, SP is automatically updated when a subroutine call is

executed or an interrupt is accepted. However, if it is used in excess of the stack area permitted by the data memory allocating configuration, the user-processed data may be lost.

The stack can be located at any position within 100_H to 1FF_H of the internal data memory. The SP is not initialized by hardware, requiring to write the initial value (the location with which the use of the stack starts) by using the initialization routine. Normally, the initial value of "FF_H" is used.

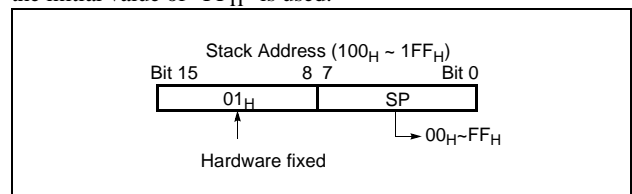

Note: The Stack Pointer must be initialized by software because its value is undefined after Reset.

Example: To initialize the SP

```
LDX    #0FFH
TXSP                      ; SP ← FFH
```

Program Counter: The Program Counter is a 16-bit wide which consists of two 8-bit registers, PCH and PCL. This counter indicates the address of the next instruction to be executed. In reset state, the program counter has reset routine address (PCH:0FF_H, PCL:0FE_H).

Program Status Word: The Program Status Word (PSW) contains several bits that reflect the current state of the CPU. The PSW is described in Figure 8-3. It contains the Negative flag, the Overflow flag, the Break flag the Half Carry (for BCD operation), the Interrupt enable flag, the Zero flag, and the Carry flag.

[Carry flag C]

This flag stores any carry or borrow from the ALU of CPU after an arithmetic operation and is also changed by the Shift Instruction or Rotate Instruction.

[Zero flag Z]

This flag is set when the result of an arithmetic operation or data transfer is "0" and is cleared by any other result.

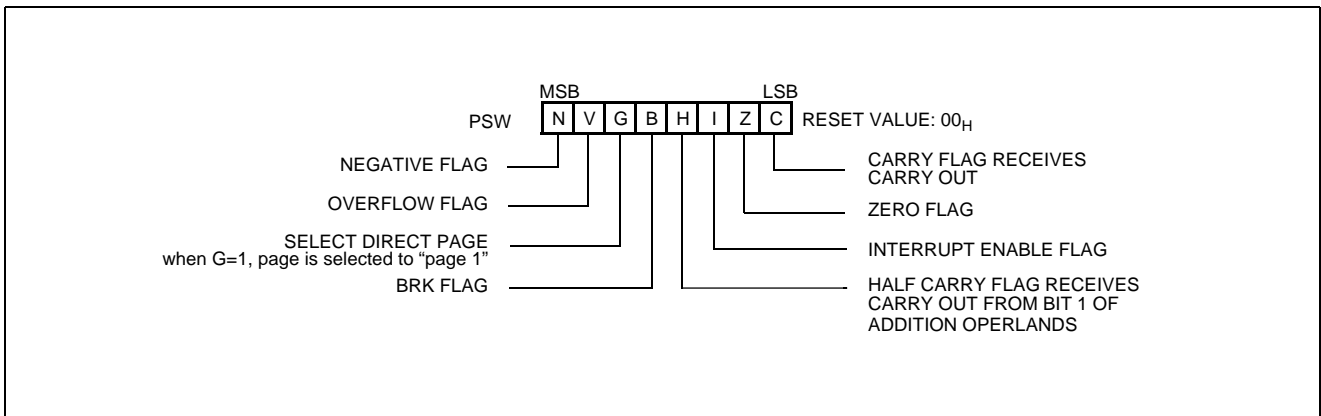

Figure 8-3 PSW (Program Status Word) Register

[Interrupt disable flag I]

This flag enables/disables all interrupts except interrupt caused by Reset or software BRK instruction. All interrupts are disabled when cleared to "0". This flag immediately becomes "0" when an interrupt is served. It is set by the EI instruction and cleared by the DI instruction.

[Half carry flag H]

After operation, this is set when there is a carry from bit 3 of ALU or there is no borrow from bit 4 of ALU. This bit can not be set or cleared except CLRV instruction with Overflow flag (V).

[Break flag B]

This flag is set by software BRK instruction to distinguish BRK from TCALL instruction with the same vector address.

[Direct page flag G]

This flag assigns RAM page for direct addressing mode. In the direct addressing mode, addressing area is from zero page 00H to 0FH when this flag is "0". If it is set to "1", addressing area is assigned 100H to 1FH. It is set by SETG instruction and cleared by CLRG.

[Overflow flag V]

This flag is set to "1" when an overflow occurs as the result of an arithmetic operation involving signs. An overflow occurs when the result of an addition or subtraction exceeds +127(7FH) or -128(80H). The CLRV instruction clears the overflow flag. There is no set instruction. When the BIT instruction is executed, bit 6 of memory is copied to this flag.

[Negative flag N]

This flag is set to match the sign bit (bit 7) status of the result of a data or arithmetic operation. When the BIT instruction is executed, bit 7 of memory is copied to this flag.

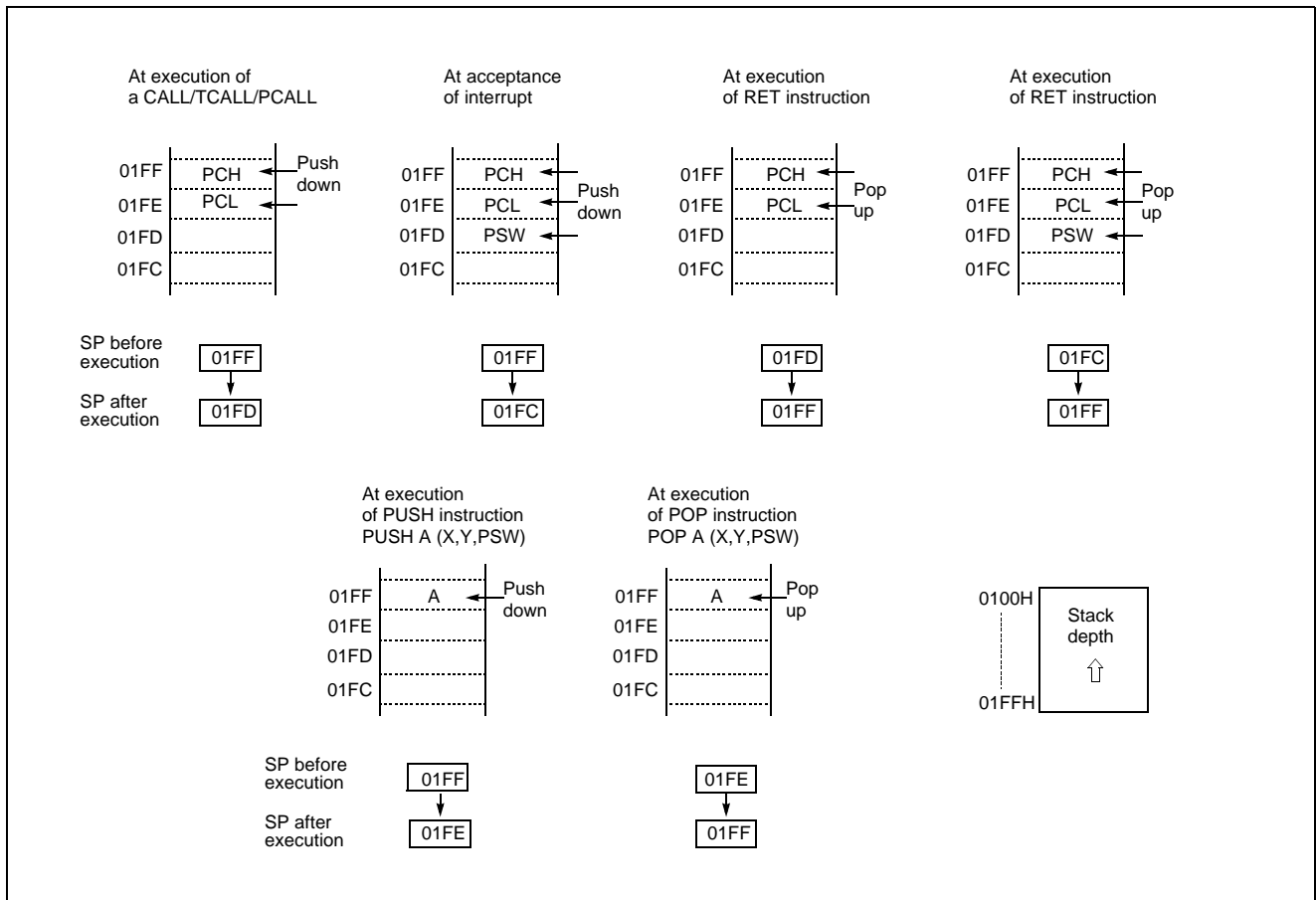

Figure 8-4 Stack Operation

8.2 Program Memory

A 16-bit program counter is capable of addressing up to 64K bytes, but this device has 24/32/48K bytes program memory space only physically implemented. Accessing a location above FFFF_H will cause a wrap-around to 0000_H.

Figure 8-5, shows a map of Program Memory. After reset, the

CPU begins execution from reset vector which is stored in address FFFE_H and FFFF_H as shown in Figure 8-6.

As shown in Figure 8-5, each area is assigned a fixed location in Program Memory. Program Memory area contains the user program

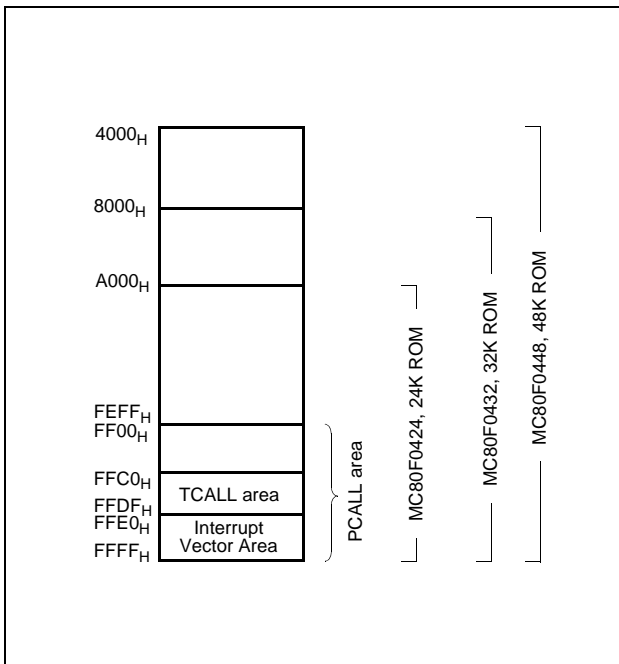

Figure 8-5 Program Memory Map

Page Call (PCALL) area contains subroutine program to reduce program byte length by using 2 bytes PCALL instead of 3 bytes CALL instruction. If it is frequently called, it is more useful to save program byte length.

Table Call (TCALL) causes the CPU to jump to each TCALL address, where it commences the execution of the service routine. The Table Call service area spaces 2-byte for every TCALL: 0FFC0H for TCALL15, 0FFC2H for TCALL14, etc., as shown in Figure 8-7.

Example: Usage of TCALL

```

LDA    #5
TCALL  0FH
:
:
;
;TABLE CALL ROUTINE
;
FUNC_A: LDA  LRG0
        RET
;
FUNC_B: LDA  LRG1
        RET
;
;TABLE CALL ADD. AREA
;
        ORG  0FFC0H
        DW  FUNC_A
        DW  FUNC_B
    
```

Annotations: A bracket on the right indicates that the TCALL instruction is 1 byte instead of 3 bytes. A bracket at the bottom indicates the TCALL address area. Circled numbers 1 and 2 point to the RET instructions in the service routines.

The interrupt causes the CPU to jump to specific location, where it commences the execution of the service routine. The External interrupt 0, for example, is assigned to location 0FFFC_H. The interrupt service locations spaces 2-byte interval: 0FFFA_H and 0FFFB_H for External Interrupt 1, 0FFFC_H and 0FFFD_H for External Interrupt 0, etc.

Any area from 0FF00_H to 0FFFF_H, if it is not going to be used, its service location is available as general purpose Program Memory.

Address	Vector Area Memory
0FFE0 _H	Basic Interval Timer
E2	Watch / Watchdog Timer Interrupt
E4	A/D Converter
E6	Timer/Counter 4 Interrupt
E8	Timer/Counter 3 Interrupt
EA	Timer/Counter 2 Interrupt
EC	Timer/Counter 1 Interrupt
EE	Timer/Counter 0 Interrupt
F0	Serial Input/Output (SIO)
F2	UART1
F4	UART0
F6	External Interrupt 3
F8	External Interrupt 2
FA	External Interrupt 1
FC	External Interrupt 0
FE	RESET

Figure 8-6 Interrupt Vector Area

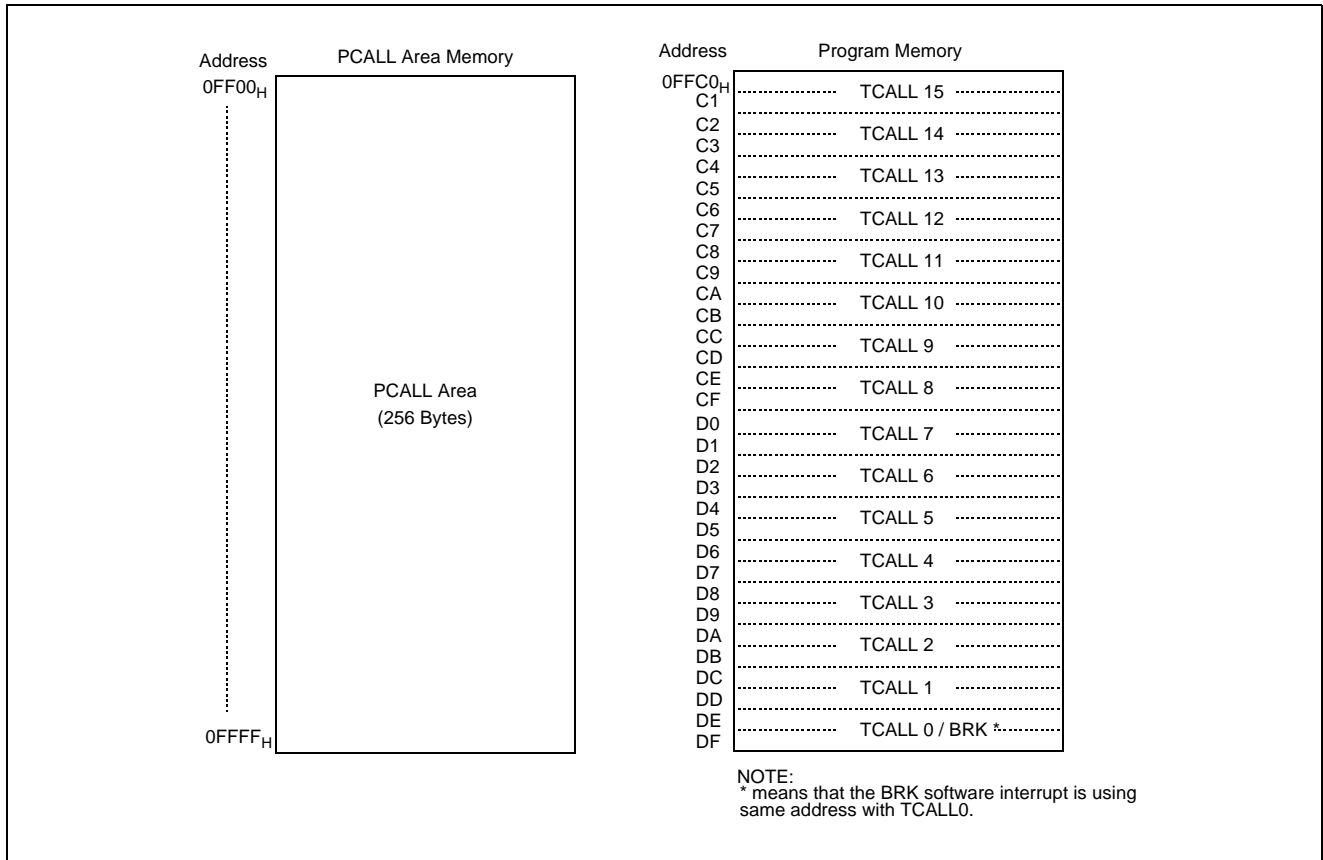
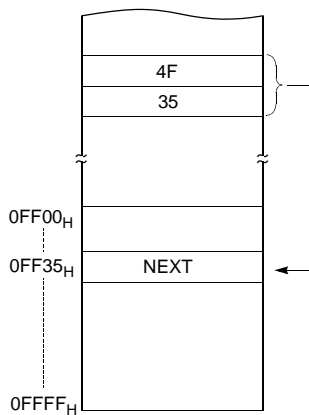

Figure 8-7 PCALL and TCALL Memory Area

PCALL → rel

4F35 PCALL 35H



TCALL → n

4A TCALL 4

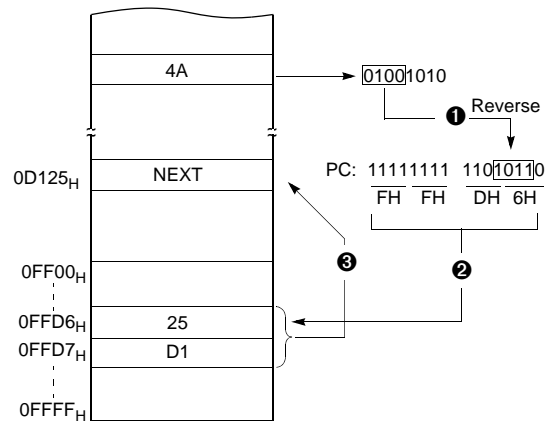

Example: The usage software example of Vector address for MC80F0448.

```

;Interrupt Vector Table
    ORG    0FFE0H
    DW    BIT_TIMER    ; BIT
    DW    WATCH_WDT    ; WDT & WT
    DW    ADC           ; AD Converter
    DW    TIMER4       ; Timer-4
    DW    TIMER3       ; Timer-3
    DW    TIMER2       ; Timer-2
    DW    TIMER1       ; Timer-1
    DW    TIMER0       ; Timer-0
    DW    SIO          ; Serial Interface
    DW    UART1        ; UART1 Rx/Tx
    DW    UART0        ; UART0 Rx/Tx
    DW    INT3         ; Ext Int.3
    DW    INT2         ; Ext Int.2
    DW    INT1         ; Ext Int.1
    DW    INT0         ; Ext Int.0
    DW    RESET        ; Reset

    ORG    04000H      ; 48K bytes ROM Start address
;*****
;          MAIN      PROGRAM      *
;*****
RESET:    DI          ;Disable All Interrupt
RAMCLEAR:
    LDX    #00H      ;USER RAM START ADDRESS LOAD !
    LDY    #0
RAMCLR1:
    LDA    #00H      ;Page0 Ram Clear(0000h ~ 00BFh)
    STA    {X}+      ;
    CMPX  #0C0H      ;
    BNE    RAMCLR1   ;

    INC    Y          ;
    STY    !RPR      ;Page1 Ram Select
    SETG                   ;G-FLAG SET !

    LDX    #00H
RAMCLR2:
    LDA    #00H
    STA    {X}+
    CMPX  #00H
    BNE    RAMCLR2

    INC    Y
    CMPY  #6
    BCS   RAMCLR3    ;Page1 ~ Page5 Clear(0100h ~ 04FFh)

    STY    !RPR
    SETG

    BRA                   RAMCLR2

RAMCLR3:
    STY    !RPR      ;Page6 Clear(0600h ~ 063Fh)
    SETG
    LDA    #00H      ;A <-- #0
    STA    {X}+
    CMPX  #40H      ;
    BNE    RAMCLR3

    CLRG                   ;G-FLAG CLEAR !

    LDX    #0FFH
    TXSP                   ;Initial Stack Point (01FFh)

```

8.3 Data Memory

Figure 8-8 shows the internal Data Memory space available. Data Memory is divided into three groups, a user RAM, control registers, and Stack memory.

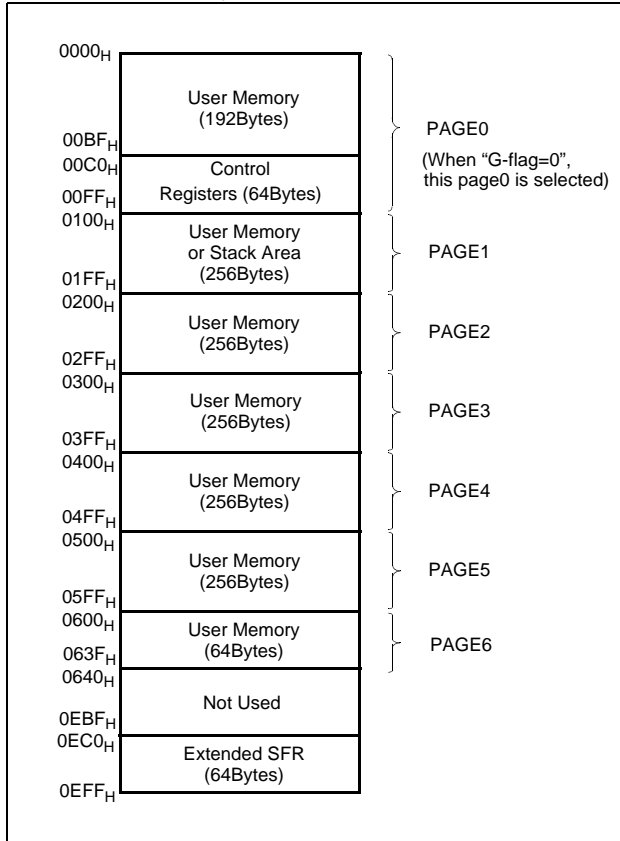

Figure 8-8 Data Memory Map

User Memory

The MC80F0424/0432/0448 has 1.5kbytes for the user memory (RAM). RAM pages are selected by RPR (See Figure 8-9).

Note: After setting RPR(RAM Page Select Register), be sure to execute SETG instruction. When executing CLRG instruction, be selected PAGE0 regardless of RPR.

Control Registers

The control registers are used by the CPU and Peripheral function blocks for controlling the desired operation of the device. Therefore these registers contain control and status bits for the interrupt system, the timer/ counters, analog to digital converters and I/O ports. The control registers are in address range of 0C0H to 0FFH.

Note that unoccupied addresses may not be implemented on the chip. Read accesses to these addresses will in general return random data, and write accesses will have an indeterminate effect.

More detailed informations of each register are explained in each peripheral section.

Note: Write only registers can not be accessed by bit manipulation instruction. Do not use read-modify-write instruction. Use byte manipulation instruction, for example "LDM".

Example; To write at CKCTLR

```
LDM CLCTLR, #0AH ;Divide ratio(+32)
```

Stack Area

The stack provides the area where the return address is saved before a jump is performed during the processing routine at the execution of a subroutine call instruction or the acceptance of an interrupt.

When returning from the processing routine, executing the subroutine return instruction [RET] restores the contents of the program counter from the stack; executing the interrupt return instruction [RETI] restores the contents of the program counter and flags.

The save/restore locations in the stack are determined by the stack pointed (SP). The SP is automatically decreased after the saving, and increased before the restoring. This means the value of the SP indicates the stack location number for the next save. Refer to Figure 8-4 on page 26.

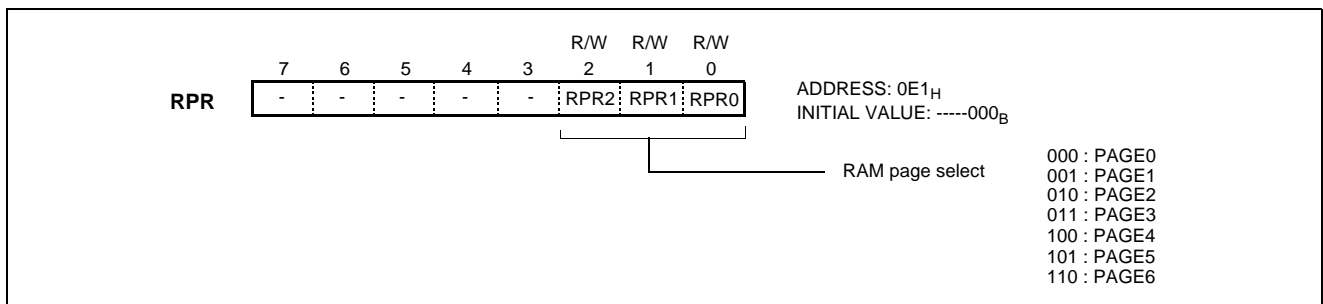

Figure 8-9 RPR(RAM Page Select Register)

Address	Register Name	Symbol	R/W	Initial Value								Addressing mode	
				7	6	5	4	3	2	1	0		
00C0	R0 port data register	R0	R/W	0	0	0	0	0	0	0	0	0	byte, bit ¹
00C1	R0 port I/O direction register	R0IO	W	0	0	0	0	0	0	0	0	0	byte ²
00C2	R1 port data register	R1	R/W	0	0	0	0	0	0	0	0	0	byte, bit
00C3	R1 port I/O direction register	R1IO	W	0	0	0	0	0	0	0	0	0	byte
00C4	R2 port data register	R2	R/W	-	-	-	-	0	0	0	0	0	byte, bit
00C5	R2 port I/O direction register	R2IO	W	-	-	-	-	0	0	0	0	0	byte
00C6	R3 port data register	R3	R/W	0	0	0	0	0	0	0	0	0	byte, bit
00C7	R3 port I/O direction register	R3IO	W	0	0	0	0	0	0	0	0	0	byte
00C8	R4 port data register	R4	R/W	0	0	0	0	0	0	0	0	0	byte, bit
00C9	R4 port I/O direction register	R4IO	W	0	0	0	0	0	0	0	0	0	byte
00CA	R5 port data register	R5	R/W	-	-	-	0	0	0	0	0	0	byte, bit
00CB	R5 port I/O direction register	R5IO	W	-	-	-	0	0	0	0	0	0	byte
00CC	R6 port data register	R6	R/W	0	0	0	0	0	0	0	0	0	byte, bit
00CD	R6 port I/O direction register	R6IO	W	0	0	0	0	0	0	0	0	0	byte
00CE	R7 port data register	R7	R/W	0	0	0	0	0	0	0	0	0	byte, bit
00CF	R7 port I/O direction register	R7IO	W	0	0	0	0	0	0	0	0	0	byte
00D0	Timer 0 mode control register	TM0	R/W	-	-	0	0	0	0	0	0	0	byte, bit
00D1	Timer 0 register	T0	R	0	0	0	0	0	0	0	0	0	byte
	Timer 0 data register	TDR0	W	1	1	1	1	1	1	1	1	1	
	Timer 0 capture data register	CDR0	R	0	0	0	0	0	0	0	0	0	
00D2	Timer 1 mode control register	TM1	R/W	0	0	0	0	0	0	0	0	0	byte, bit
00D3	Timer 1 data register	TDR1	W	1	1	1	1	1	1	1	1	1	byte
	Timer 1 PWM period register	T1PPR	W	1	1	1	1	1	1	1	1	1	
00D4	Timer 1 register	T1	R	0	0	0	0	0	0	0	0	0	byte
	Timer 1 PWM duty register	T1PDR	R/W	0	0	0	0	0	0	0	0	0	
	Timer 1 capture data register	CDR1	R	0	0	0	0	0	0	0	0	0	
00D5	Timer 1 PWM high register	T1PWHR	W	-	-	-	-	0	0	0	0	0	byte
00D6	Timer 2 mode control register	TM2	R/W	-	-	0	0	0	0	0	0	0	byte, bit
00D7	Timer 2 register	T2	R	0	0	0	0	0	0	0	0	0	byte
	Timer 2 data register	TDR2	W	1	1	1	1	1	1	1	1	1	
	Timer 2 capture data register	CDR2	R	0	0	0	0	0	0	0	0	0	
00D8	Timer 3 mode control register	TM3	R/W	0	0	0	0	0	0	0	0	0	byte, bit

Table 8-1 Control Registers

Address	Register Name	Symbol	R/W	Initial Value								Addressing mode
				7	6	5	4	3	2	1	0	
00D9	Timer 3 data register	TDR3	W	1	1	1	1	1	1	1	1	byte
	Timer 3 PWM period register	T3PPR	W	1	1	1	1	1	1	1	1	
00DA	Timer 3 register	T3	R	0	0	0	0	0	0	0	0	byte
	Timer 3 PWM duty register	T3PDR	R/W	0	0	0	0	0	0	0	0	
	Timer 3 capture data register	CDR3	R	0	0	0	0	0	0	0	0	
00DB	Timer 3 PWM high register	T3PWHR	W	-	-	-	-	0	0	0	0	byte
00DC	Timer 4 mode control register	TM4	R/W	-	-	0	0	0	0	0	0	byte, bit
00DD	Timer 4 low register	T4L	R	0	0	0	0	0	0	0	0	byte
	Timer 4 low data register	TDR4L	W	1	1	1	1	1	1	1	1	
	Timer 4 capture low data register	CDR4L	R	0	0	0	0	0	0	0	0	
00DE	Timer 4 high register	T4H	R	0	0	0	0	0	0	0	0	byte
	Timer 4 high data register	TDR4H	W	1	1	1	1	1	1	1	1	
	Timer 4 capture high data register	CDR4H	R	0	0	0	0	0	0	0	0	
00DF	Interrupt flag register	IFR	R/W	-	-	0	0	0	0	0	0	byte, bit
00E0	Buzzer driver register	BUZR	W	1	1	1	1	1	1	1	1	byte
00E1	RAM page selection register	RPR	R/W	-	-	-	-	-	0	0	0	byte, bit
00E2	SIO mode control register	SIOM	R/W	0	0	0	0	0	0	0	1	byte, bit
00E3	SIO data shift register	SIOR	R/W	Undefined								byte, bit
00E4	Reserved											
00E5	Reserved											
00E6	UART0 mode register	ASIMR	R/W	0	0	0	0	-	0	0	-	byte, bit
00E7	UART0 status register	ASISR	R	-	-	-	-	-	0	0	0	byte
00E8	UART0 Baud rate generator control register	BRGCR	R/W	-	0	0	1	0	0	0	0	byte, bit
00E9	UART0 Receive buffer register	RXR	R	0	0	0	0	0	0	0	0	byte
	UART0 Transmit shift register	TXR	W	1	1	1	1	1	1	1	1	
00EA	Interrupt enable register high	IENH	R/W	0	0	0	0	0	0	0	0	byte, bit
00EB	Interrupt enable register low	IENL	R/W	0	0	0	0	0	0	0	0	byte, bit
00EC	Interrupt request register high	IRQH	R/W	0	0	0	0	0	0	0	0	byte, bit
00ED	Interrupt request register low	IRQL	R/W	0	0	0	0	0	0	0	0	byte, bit
00EE	Interrupt edge selection register	IEDS	R/W	0	0	0	0	0	0	0	0	byte, bit
00EF	A/D converter mode control register	ADCM	R/W	0	0	0	0	0	0	0	1	byte, bit
00F0	A/D converter result high register	ADCRH	R	0	1	1	Undefined					byte
00F1	A/D converter result low register	ADCRL	R	Undefined								byte

Table 8-1 Control Registers

Address	Register Name	Symbol	R/W	Initial Value								Addressing mode	
				7	6	5	4	3	2	1	0		
00F2	Basic interval timer register	BITR	R	Undefined								byte	
	Clock control register	CKCTLR	W	0	-	0	1	0	1	1	1		
00F3	System clock mode register	SCMR	R/W	-	-	-	-	-	0	0	0	0	byte, bit
00F4	Watch dog timer register	WDTR	W	0	1	1	1	1	1	1	1	1	byte
	Watch dog timer data register	WDTDR	R	Undefined									
00F5	Stop & sleep mode control register	SSCR	W	0	0	0	0	0	0	0	0	0	byte
00F6	Watch timer mode register	WTMR	R/W	0	-	-	0	0	0	0	0	0	byte, bit
00F7	PFD control register	PFDR	R/W	-	-	-	-	-	0	0	0	0	byte, bit
00F8	Port selection register 0	PSR0	W	0	0	0	0	0	0	0	0	0	byte
00F9	Port selection register 1	PSR1	W	-	-	-	-	0	0	0	0	0	byte
00FA	Reserved												
00FB	Reserved												
00FC	Pull-up selection register 0	PU0	W	0	0	0	0	0	0	0	0	0	byte
00FD	Pull-up selection register 1	PU1	W	0	0	0	0	0	0	0	0	0	byte
00FE	Pull-up selection register 4	PU4	W	0	0	0	0	0	0	0	0	0	byte
00FF	Pull-up selection register 7	PU7	W	0	0	0	0	0	0	0	0	0	byte
0EE6	UART1 mode register	ASIMR1	R/W	0	0	0	0	-	0	0	-	-	byte, bit
0EE7	UART1 status register	ASISR1	R	-	-	-	-	-	0	0	0	0	byte
0EE8	UART1 Baud rate generator control register	BRGCR1	R/W	-	0	0	1	0	0	0	0	0	byte, bit
0EE9	UART1 Receive buffer register	RXR1	R	0	0	0	0	0	0	0	0	0	byte
	UART1 Transmit shift register	TXR1	W	1	1	1	1	1	1	1	1	1	

Table 8-1 Control Registers

- The 'byte, bit' means registers are controlled by both bit and byte manipulation instruction. Caution) The R/W register except T1PDR and T3PDR are both can be byte and bit manipulated.
- The 'byte' means registers are controlled by only byte manipulation instruction. Do not use bit manipulation instruction such as SET1, CLR1 etc. If bit manipulation instruction is used on these registers, content of other seven bits are may varied to unwanted value.

*The mark of '-' means this bit location is reserved.

Address	Name	Bit 7	Bit 6	Bit 5	Bit 4	Bit 3	Bit 2	Bit 1	Bit 0
C0H	R0	R0 Port Data Register							
C1H	R0IO	R0 Port Direction Register							
C2H	R1	R1 Port Data Register							
C3H	R1IO	R1 Port Direction Register							
C4H	R2	-	-	-	-	R2 Port Data Register			
C5H	R2IO	-	-	-	-	R2 Port Direction Register			
C6H	R3	R3 Port Data Register							
C7H	R3IO	R3 Port Direction Register							
C8H	R4	R4 Port Data Register							
C9H	R4IO	R4 Port Direction Register							
CAH	R5	-	-	-	R5 Port Data Register				
CBH	R5IO	-	-	-	R5 Port Direction Register				
CCH	R6	R6 Port Data Register							
CDH	R6IO	R6 Port Direction Register							
CEH	R7	R7 Port Data Register							
CFH	R7IO	R7 Port Direction Register							
D0H	TM0	-	-	CAP0	T0CK2	T0CK1	T0CK0	T0CN	T0ST
D1H	T0/TDR0/ CDR0	Timer0 Register / Timer0 Data Register / Timer0 Capture Data Register							
D2H	TM1	POL	16BIT	PWM1E	CAP1	T1CK1	T1CK0	T1CN	T1ST
D3H	TDR1/ T1PPR	Timer1 Data Register / Timer1 PWM Period Register							
D4H	T1/CDR1/ T1PDR	Timer1 Register / Timer1 Capture Data Register / Timer1 PWM Duty Register							
D5H	PWM1HR	-	-	-	-	Timer1 PWM High Register			
D6H	TM2	-	-	CAP2	T2CK2	T2CK1	T2CK0	T2CN	T2ST
D7H	T2/TDR2/ CDR2	Timer2 Register / Timer2 Data Register / Timer2 Capture Data Register							
D8H	TM3	POL	16BIT	PWM3E	CAP3	T3CK1	T3CK0	T3CN	T3ST
D9H	TDR3/ T3PPR	Timer3 Data Register / Timer3 PWM Period Register							
DAH	T3/CDR3/ T3PDR	Timer3 Register / Timer3 Capture Data Register / Timer3 PWM Duty Register							
DBH	PWM3HR	-	-	-	-	Timer3 PWM High Register			
DCH	TM4	-	-	CAP4	T4CK2	T4CK1	T4CK0	T4CN	T4ST
DDH	T4L/ TDR4L/ CDR4L	Timer4 Register Low / Timer4 Data Register Low / Timer4 Capture Data Register Low							

Table 8-2 Control Register Function Description

Address	Name	Bit 7	Bit 6	Bit 5	Bit 4	Bit 3	Bit 2	Bit 1	Bit 0
DEH	T4H/ TDR4H/ CDR4H	Timer4 Register High / Timer4 Data Register High / Timer4 Capture Data Register High							
DFH	IFR	-	-	IFRX0	IFTX0	IFRX1	IFTX1	IFWT	IFWDT
E0H	BUZR	BUCK1	BUCK0	BUR5	BUR4	BUR3	BUR2	BUR1	BUR0
E1H	RPR	-	-	-	-	-	RPR2	RPR1	RPR0
E2H	SIOM	POL	IOSW	SM1	SM0	SCK1	SCK0	SIOST	SIOSF
E3H	SIOR	SIO Data Shift Register							
E4H		Reserved							
E5H		Reserved							
E6H	ASIMR	TXE	RXE	PS1	PS0	-	SL	ISRM	-
E7H	ASISR	-	-	-	-	-	PE	FE	OVE
E8H	BRGCR	-	TPS2	TPS1	TPS0	MLD3	MLD2	MLD1	MLD0
E9H	RXR	UART0 Receive Buffer Register							
	TXR	UART0 Transmit Shift Register							
EAH	IENH	INT0E	INT1E	INT2E	INT3E	UART0E	UART1E	SIOE	T0E
EBH	IENL	T1E	T2E	T3E	T4E	ADCE	WDTE	WTE	BITE
ECH	IRQH	INT0IF	INT1IF	INT2IF	INT3IF	UART0IF	UART1IF	SIOIF	T0IF
EDH	IRQL	T1IF	T2IF	T3IF	T4IF	ADCIF	WDTIF	WTIF	BITIF
EEH	IEDS	IED3H	IED3L	IED2H	IED2L	IED1H	IED1L	IED0H	IED0L
EFH	ADCM	ADEN	ADCK	ADS3	ADS2	ADS1	ADS0	ADST	ADSF
F0H	ADCRH	PSSEL1	PSSEL0	ADC8	-	-	-	ADC Result Reg. High	
F1H	ADCRL	ADC Result Register Low							
F2H	BITR ¹	Basic Interval Timer Data Register							
	CKCTLR ¹	ADRST	-	RCWDT	WDTON	BTCL	BTS2	BTS1	BTS0
F3H	SCMR	-	-	-	-	-	MCC	CS1	CS0
F4H	WDTR	WDTCL	7-bit Watchdog Timer Register						
	WDTDR	Watchdog Timer Data Register (Counter Register)							
F5H	SSCR	Stop & Sleep Mode Control Register							
F6H	WTMR	WTEN	-	-	WTIN2	WTIN1	WTIN0	WTCK1	WTCK0
F7H	PFDR	-	-	-	-	-	PFDEN	PFDM	PFDS
F8H	PSR0	PWM30	PWM10	EC1E	EC0E	INT3E	INT2E	INT1E	INT0E
F9H	PSR1	-	-	-	-	XTEN	BUZO	T20	T00
FAH		Reserved							
FBH		Reserved							
FCH	PU0	R0 Pull-up Selection Register							
FDH	PU1	R1 Pull-up Selection Register							
FEH	PU4	R4 Pull-up Selection Register							

Table 8-2 Control Register Function Description

Address	Name	Bit 7	Bit 6	Bit 5	Bit 4	Bit 3	Bit 2	Bit 1	Bit 0
FEH	PU4	R4 Pull-up Selection Register							
EE6H	ASIMR1	TXE	RXE	PS1	PS0	-	SL	ISRM	-
EE7H	ASISR1	-	-	-	-	-	PE	FE	OVE
EE8H	BRGCR1	-	TPS2	TPS1	TPS0	MLD3	MLD2	MLD1	MLD0
EE9H	RXR1	UART1 Receive Buffer Register							
	TXR1	UART1 Transmit Shift Register							

Table 8-2 Control Register Function Description

1. The register BITR and CKCLR are located at same address. Address ECH is read as BITR, written to CKCLR.

Caution) The registers of dark-shaded area can not be accessed by bit manipulation instruction such as "SET1, CLR1", but should be accessed by register operation instruction such as "LDM dp,#imm".

8.4 Addressing Mode

The MC800 series MCU uses six addressing modes;

- Register addressing
- Immediate addressing
- Direct page addressing
- Absolute addressing
- Indexed addressing
- Register-indirect addressing

8.4.1 Register Addressing

Register addressing accesses the A, X, Y, C and PSW.

8.4.2 Immediate Addressing → #imm

In this mode, second byte (operand) is accessed as a data immediately.

Example:

```
0435 ADC #35H
```



When G-flag is 1, then RAM address is defined by 16-bit address which is composed of 8-bit RAM paging register (RPR) and 8-bit immediate data.

Example: G=1

```
E45535 LDM 35H, #55H
```

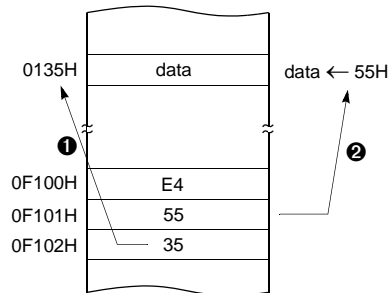

8.4.3 Direct Page Addressing → dp

In this mode, a address is specified within direct page.

Example; G=0

```
C535 LDA 35H ;A ←RAM[35H]
```

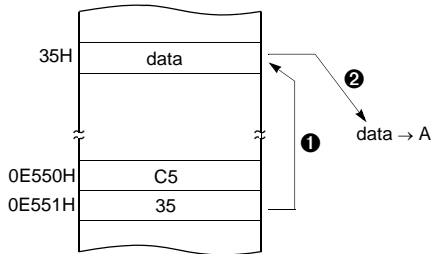

```
983501 INC !0135H ;A ←ROM[135H]
```

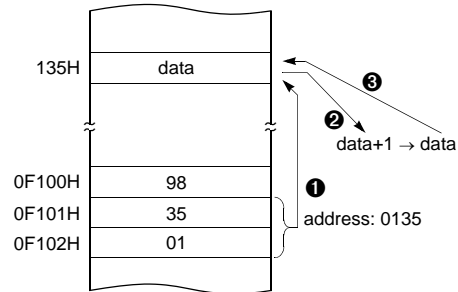

8.4.4 Absolute Addressing → !abs

Absolute addressing sets corresponding memory data to Data, i.e. second byte (Operand I) of command becomes lower level address and third byte (Operand II) becomes upper level address. With 3 bytes command, it is possible to access to whole memory area.

ADC, AND, CMP, CMPX, CMPY, EOR, LDA, LDX, LDY, OR, SBC, STA, STX, STY

Example;

```
0735F0 ADC !0F035H ;A ←ROM[0F035H]
```

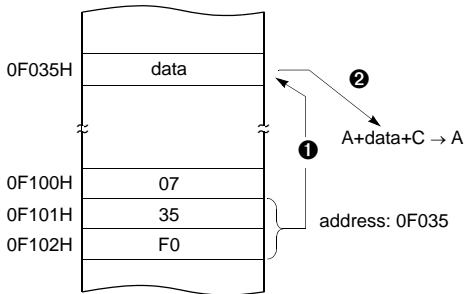

The operation within data memory (RAM)
ASL, BIT, DEC, INC, LSR, ROL, ROR

Example; Addressing accesses the address 0135H regardless of G-flag.

8.4.5 Indexed Addressing

X indexed direct page (no offset) → {X}

In this mode, a address is specified by the X register.

ADC, AND, CMP, EOR, LDA, OR, SBC, STA, XMA

Example; X=15H, G=1

```
D4 LDA {X} ;ACC←RAM[X].
```

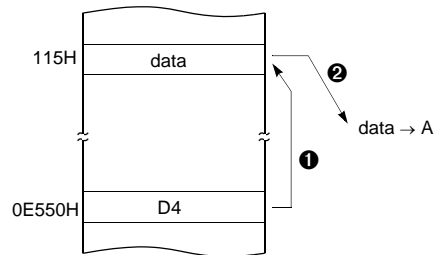

X indexed direct page, auto increment → {X}+

In this mode, a address is specified within direct page by the X register and the content of X is increased by 1.

LDA, STA

Example; G=0, X=35H

```
DB LDA {X}+
```

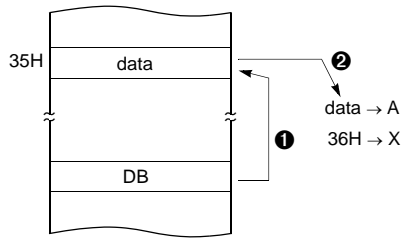

```
D500FA LDA !0FA00H+Y
```

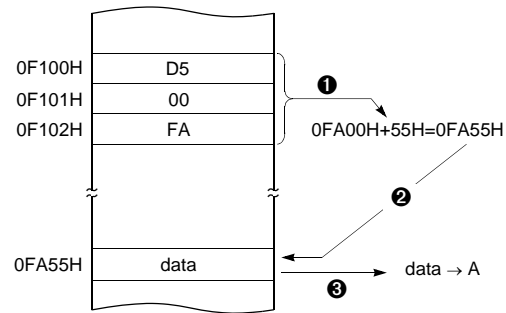

X indexed direct page (8 bit offset) → dp+X

This address value is the second byte (Operand) of command plus the data of X-register. And it assigns the memory in Direct page.

ADC, AND, CMP, EOR, LDA, LDY, OR, SBC, STA STY, XMA, ASL, DEC, INC, LSR, ROL, ROR

Example; G=0, X=0F5H

```
C645 LDA 45H+X
```

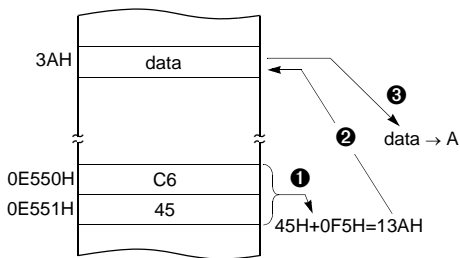

8.4.6 Indirect Addressing

Direct page indirect → [dp]

Assigns data address to use for accomplishing command which sets memory data (or pair memory) by Operand. Also index can be used with Index register X,Y.

JMP, CALL

Example; G=0

```
3F35 JMP [35H]
```

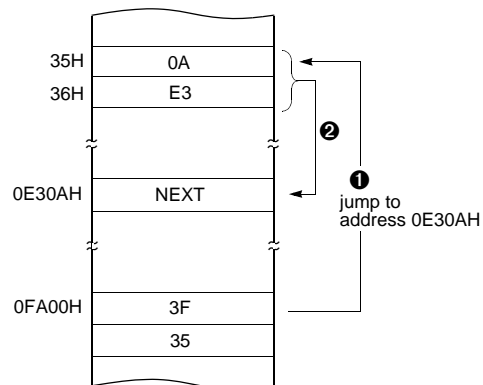

Y indexed direct page (8 bit offset) → dp+Y

This address value is the second byte (Operand) of command plus the data of Y-register, which assigns Memory in Direct page.

This is same with above (2). Use Y register instead of X.

Y indexed absolute → !abs+Y

Sets the value of 16-bit absolute address plus Y-register data as Memory. This addressing mode can specify memory in whole area.

Example; Y=55H

X indexed indirect → [dp+X]

Processes memory data as Data, assigned by 16-bit pair memory which is determined by pair data [dp+X+1][dp+X] Operand plus X-register data in Direct page.

ADC, AND, CMP, EOR, LDA, OR, SBC, STA

Example; G=0, X=10H

1625 ADC [25H+X]

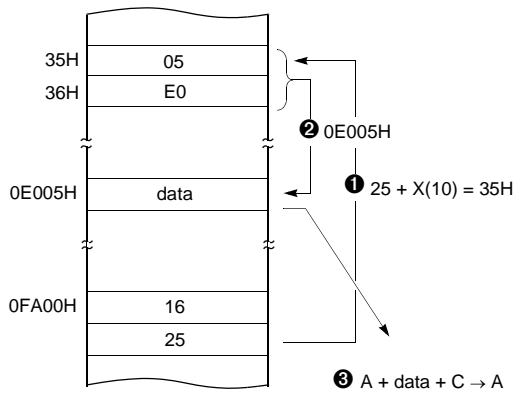

Y indexed indirect $\rightarrow [dp]+Y$

Processes memory data as Data, assigned by the data [dp+1][dp] of 16-bit pair memory paired by Operand in Direct page plus Y-register data.

ADC, AND, CMP, EOR, LDA, OR, SBC, STA

Example; G=0, Y=10_H

1725 ADC [25H]+Y

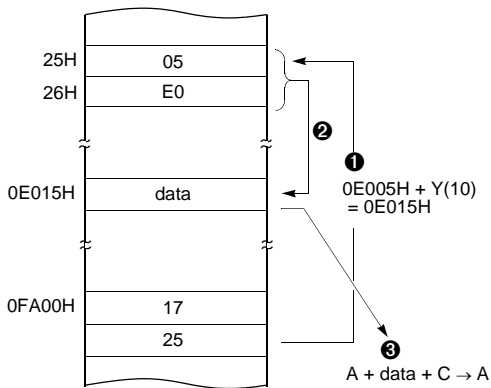

Absolute indirect $\rightarrow [!abs]$

The program jumps to address specified by 16-bit absolute address.

JMP

Example; G=0

1F25E0 JMP [!0C025H]

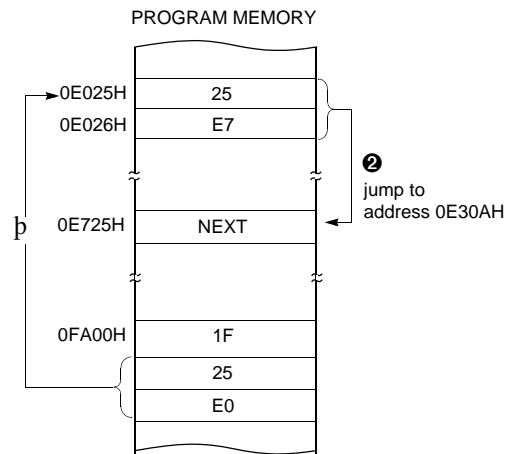

9. I/O PORTS

The MC80F0424/0432/0448 has eight ports (R0, R1, R2, R3, R4, R5, R6 and R7). These ports pins may be multiplexed with an alternate function for the peripheral features on the device. R3 port can drive maximum 20mA of high current in output low state, so it can directly drive LED device.

All pins have data direction registers which can define these ports as output or input. A “1” in the port direction register configure the corresponding port pin as output. Conversely, write “0” to the corresponding bit to specify it as input pin. For example, to use the even numbered bit of R0 as output ports and the odd numbered bits as input ports, write “55H” to address 0C1H (R0 port direction register) during initial setting as shown in Figure 9-1.

All the port direction registers in the MC80F0424/0432/0448 have 0 written to them by reset function. On the other hand, its initial status is input.

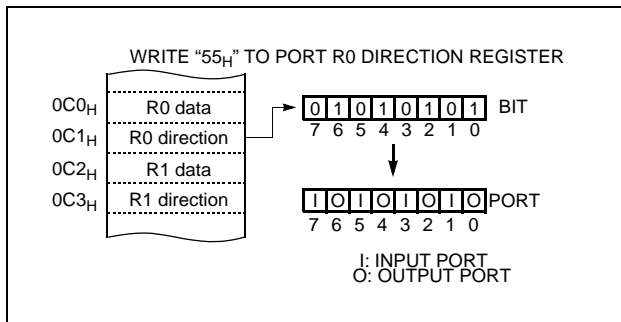
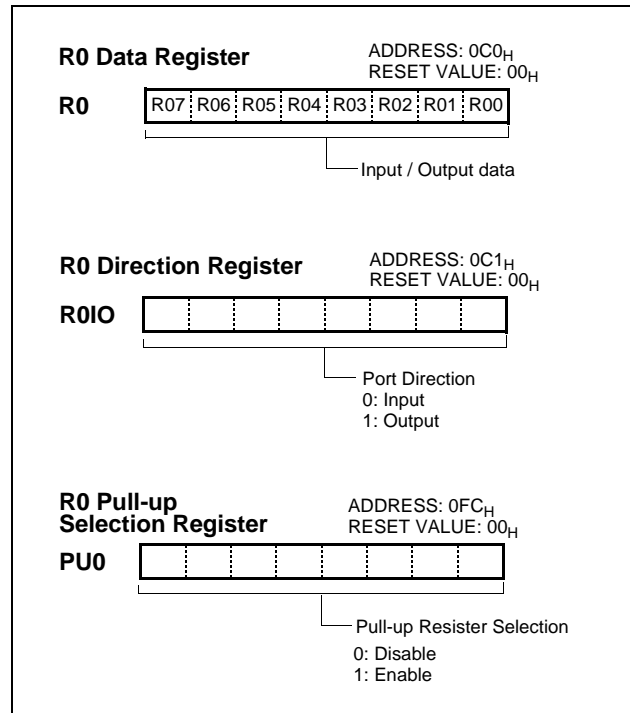

Figure 9-1 Example of port I/O assignment

R0 and R0IO register: R0 is an 8-bit CMOS bidirectional I/O port (address 0C0H). Each I/O pin can independently used as an input or an output through the R0IO register (address 0C1H). The on-chip pull-up resistor can be connected to them in 1-bit units with a pull-up selection register 0 (PU0).



R1 and R1IO register: R1 is an 8-bit CMOS bidirectional I/O port (address 0C2H). Each I/O pin can independently used as an input or an output through the R1IO register (address 0C3H). The on-chip pull-up resistor can be connected to them in 1-bit units with a pull-up selection register 1 (PU1).

In addition, Port R1 is multiplexed with various special features. The control register PSR0 (address 0F8H) and PSR1 (address 0F9H) controls the selection of alternate function. After reset, this value is “0”, port may be used as normal I/O port.

To use alternate function such as external interrupt, event counter input or timer clock output, write “1” in the corresponding bit of PSR0 or PSR1. Regardless of the direction register R1IO, PSR0 or PSR1 is selected to use as alternate functions, port pin can be used as a corresponding alternate features.

Port Pin	Alternate Function
R10	INT0 (External Interrupt 0)
R11	INT1 (External Interrupt 1)
R12	INT2 (External Interrupt 2)
R13	BUZO (Square-wave output for buzzer)
R14	T0O (Timer 0 Clock-out)
R15	EC0 (Event counter input to Counter 0)
R16	-
R17	-

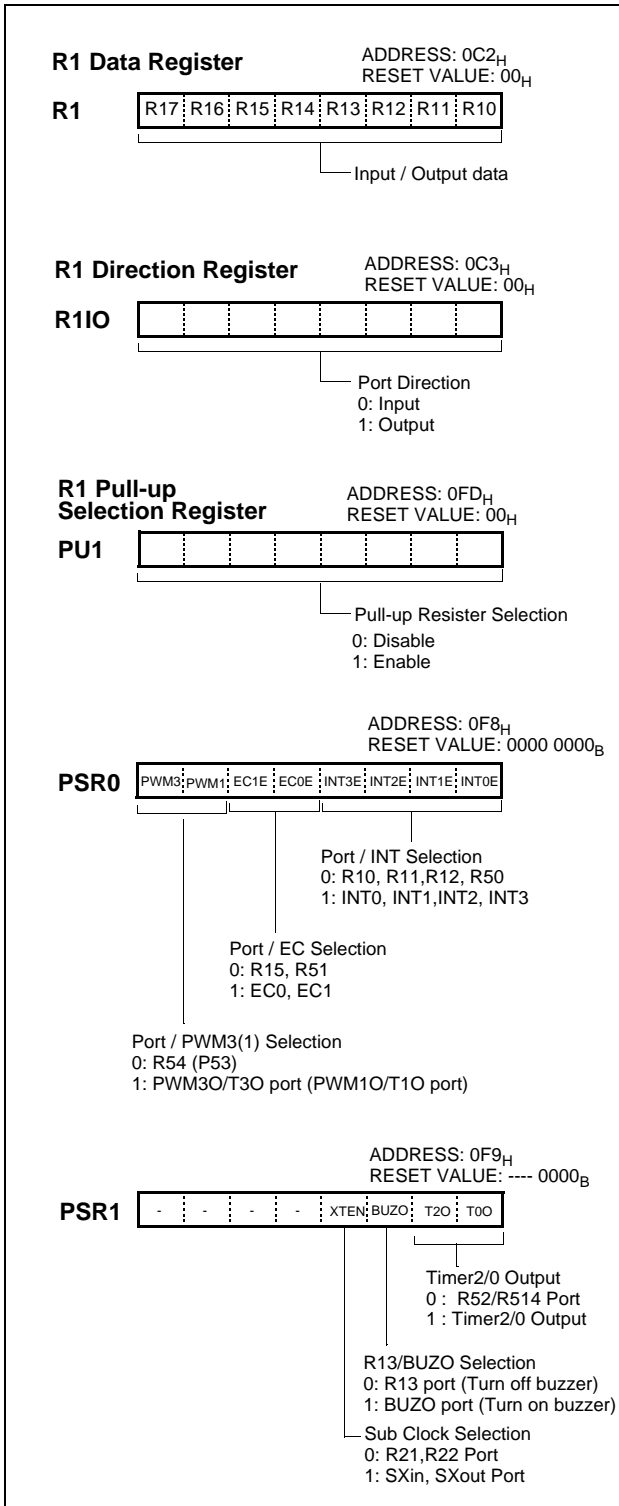

R2 and R2IO register: R2 is an 4-bit CMOS bidirectional I/O port (address 0C4_H). Each I/O pin can independently used as an input or an output through the R2IO register (address 0C5_H).

In addition, Port R2 is multiplexed with various special features. The control register PSR1 (address 0F9_H) controls the selection of alternate function. After reset, this value is "0", port may be used as normal I/O port.

To use alternate function such as sub clock input and sub clock output, write "1" in the corresponding bit of PSR1.

Port Pin	Alternate Function
R20	-
R21	SX _{IN} (sub clock input)
R22	SX _{OUT} (sub clock output)
R23	-

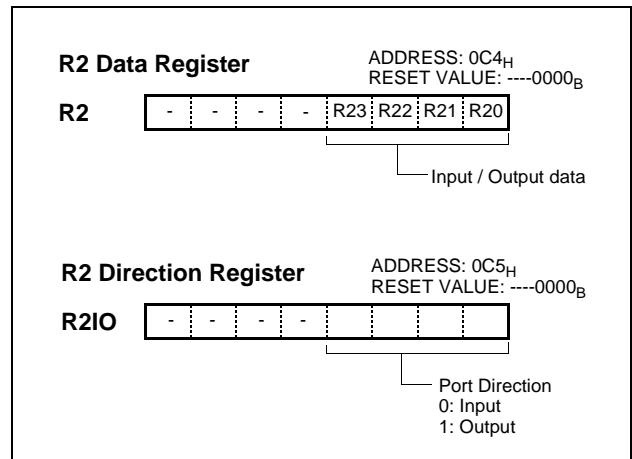

R3 and R3IO register: R3 is an 8-bit CMOS bidirectional I/O port (address 0C6_H). Each I/O pin can independently used as an input or an output through the R3IO register (address 0C7_H).

In addition, Port R3 is multiplexed with various special features. After reset, this value is "0", port may be used as normal I/O port.

To use alternate function, write "1" in the corresponding bit of ASIMR1 and BRGCR1 register.

Port Pin	Alternate Function
R30	-
R31	ACLK1 (UART1 clock input)
R32	RxD1 (UART1 data input)
R33	TxD1 (UART1 data output)-
R33	-
R33	-
R33	-
R37	-

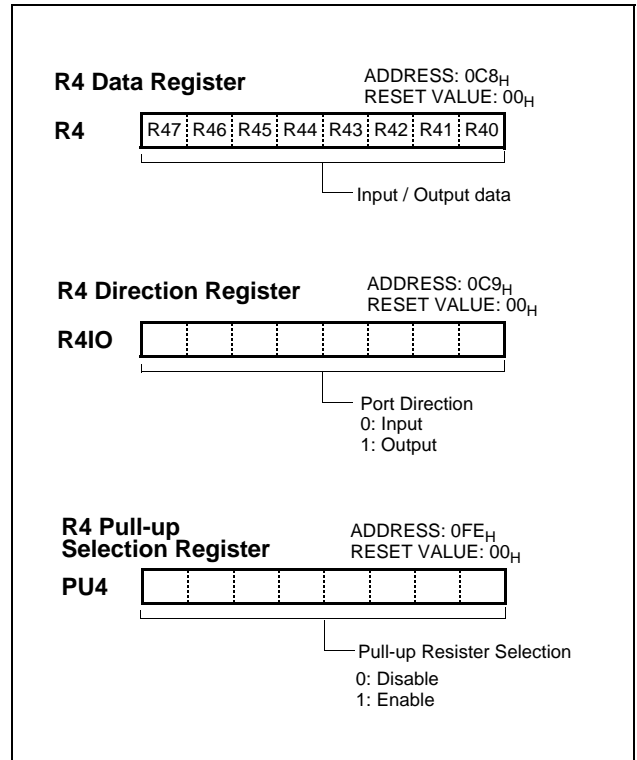
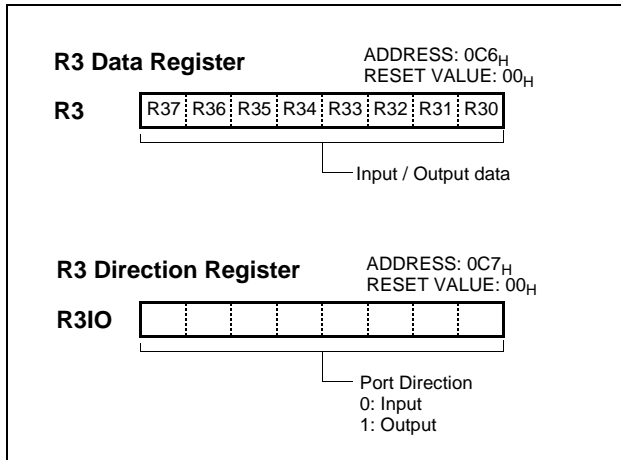

R4 and R4IO register: R4 is an 8-bit CMOS bidirectional I/O port (address 0C8_H). Each I/O pin can independently used as an input or an output through the R4IO register (address 0C9_H). The on-chip pull-up resistor can be connected to them in 1-bit units with a pull-up selection register 4 (PU4).

In addition, Port R4 is multiplexed with various special features. After reset, this value is “0”, port may be used as normal I/O port. To use alternate function, write “1” in the corresponding bit of ASIMR and BRGCR register.

Port Pin	Alternate Function
R40	-
R41	-
R42	SCK (SIO clock input/output)
R43	SI (SIO data input)
R44	SO (Serial1 data output)
R45	ACLK (Asynchronous serial clock input)
R46	RxD (Asynchronous serialdata input)
R47	TxD (Asynchronous serial data output)

Port Pin	Alternate Function
R50	INT3 (External Interrupt 3)
R51	EC1 (Event counter input to Counter 2)
R52	T2O (Timer 2 Clock-out)
R53	PWM1O (PWM1 output) / T1O
R54	PWM3O (PWM3 output) / T3O

R5 and R5IO register: R5 is an 5-bit CMOS bidirectional I/O port (address 0CA_H). Each I/O pin can independently used as an input or an output through the R5IO register (address 0CB_H).

In addition, Port R5 is multiplexed with various special features. The control register PSR0 (address 0F8_H) and PSR1 (address 0F9_H) controls the selection of alternate function. After reset, this value is “0”, port may be used as normal I/O port.

To use alternate function such as external interrupt, event counter input, timer clock output or PWM output, write “1” in the corresponding bit of PSR0 or PSR1. Regardless of the direction register R5IO, PSR0 or PSR1 is selected to use as alternate functions, port pin can be used as a corresponding alternate features.

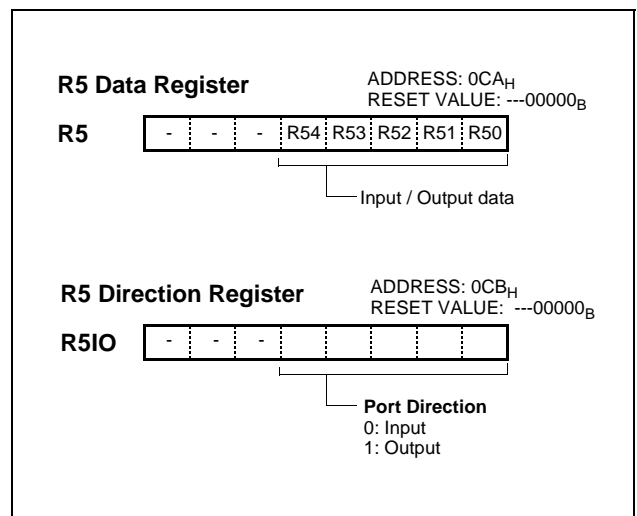

R6 and R6IO register: R6 is an 8-bit CMOS bidirectional I/O port (address 0CC_H). Each I/O pin can independently used as an input or an output through the R6IO register (address 0CD_H).

In addition, Port R6 is multiplexed with AD converter analog input AN0~AN7.

Port Pin	Alternate Function
R60	AN0 (ADC input channel 0)
R61	AN1 (ADC input channel 1)
R62	AN2 (ADC input channel 2)
R63	AN3 (ADC input channel 3)
R64	AN4 (ADC input channel 4)
R65	AN5 (ADC input channel 5)
R66	AN6 (ADC input channel 6)
R67	AN7 (ADC input channel 7)

R6IO (address CD_H) controls the direction of the R6 pins, except when they are being used as analog input channels. The user don't have to keep the pins configured as inputs when using them as analog input channels, because the analog input mode is activated by the setting of ADC enable bit of ADCM register and ADC channel selection.

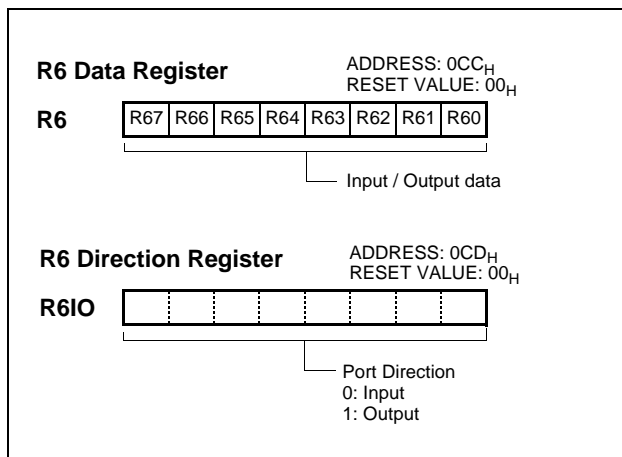

R7 and R7IO register: R7 is an 8-bit CMOS bidirectional I/O port (address 0CE_H). Each I/O pin can independently used as an input or an output through the R7IO register (address 0CF_H). The on-chip pull-up resistor can be connected to them in 1-bit units with a R7 pull-up selection register (PU7).

In addition, Port R7 is multiplexed with AD converter analog input channel AN8~AN15.

Port Pin	Alternate Function
R70	AN8 (ADC input channel 8)
R71	AN9 (ADC input channel 9)
R72	AN10 (ADC input channel 10)
R73	AN11 (ADC input channel 11)
R74	AN12 (ADC input channel 12)
R75	AN13 (ADC input channel 13)
R76	AN14 (ADC input channel 14)
R77	AN15 (ADC input channel 15)

R7IO (address CF_H) controls the direction of the R7 pins, except when they are being used as analog input channels. The user don't have to keep the pins configured as inputs when using them as analog input channels, because the analog input mode is activated by the setting of ADC enable bit of ADCM register and ADC channel selection.

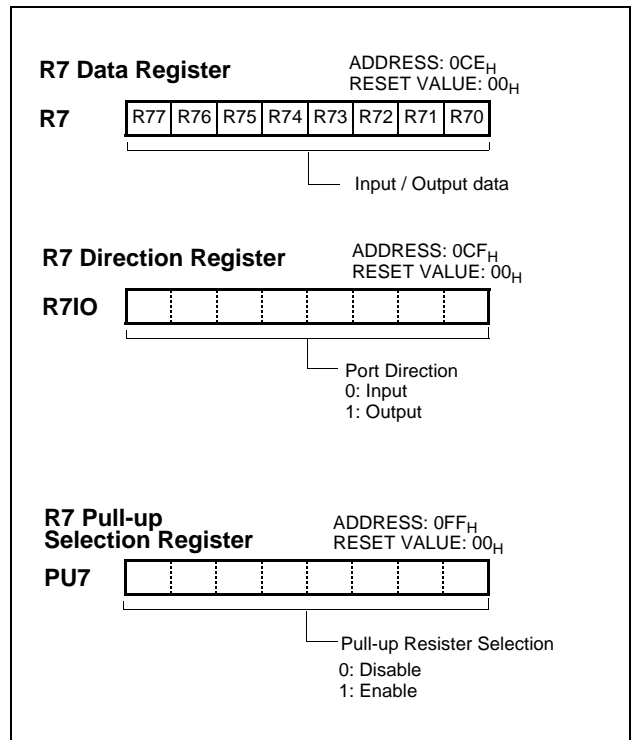

10. CLOCK GENERATOR

As shown in Figure 10-1, the clock generator produces the basic clock pulses which provide the system clock to be supplied to the CPU and the peripheral hardware. It contains two oscillators which are main-frequency clock oscillator and a sub-frequency clock oscillator. The system clock operation can be easily obtained by attaching a crystal or a ceramic resonator between the X_{IN} and X_{OUT} pin and the SX_{IN} and SX_{OUT} pin, respectively. The system clock can also be obtained from the external oscillator. In this case, it is necessary to input a external clock signal to the X_{IN} pin and open the X_{OUT} pin. There are no requirements on the duty cycle of the external clock signal, since the input to the internal clocking circuitry is through a divide-by-two flip-flop, but minimum and maximum high and low times specified on the data sheet must be observed.

The internal system clock can be selected by bit0 and bit1 of the

system clock control register (SCMR). The registers are shown in Figure 10-2. In case of selecting sub clock, to oscillate or stop the main clock is decided by MCC bit (SCMR.2).

On the initial reset, internal system clock is PS1 which is the fastest and other clock can be provided by bit0 and bit1 of SCMR.

The clock among the not-divided original clock and clocks divided by 1, 2, 4,..., up to 4096 can be provided to the peripheral block, Peripheral clock is enabled or disabled by STOP instruction. The peripheral clock is controlled by clock control register (CKCTRL). See "11. BASIC INTERVAL TIMER" on page 46 for details.

The subclock oscillation connected to SXIN and SXOUT pin is enabled by the set of corresponding XTEN bit of PSR1 register (See Figure 10-3).

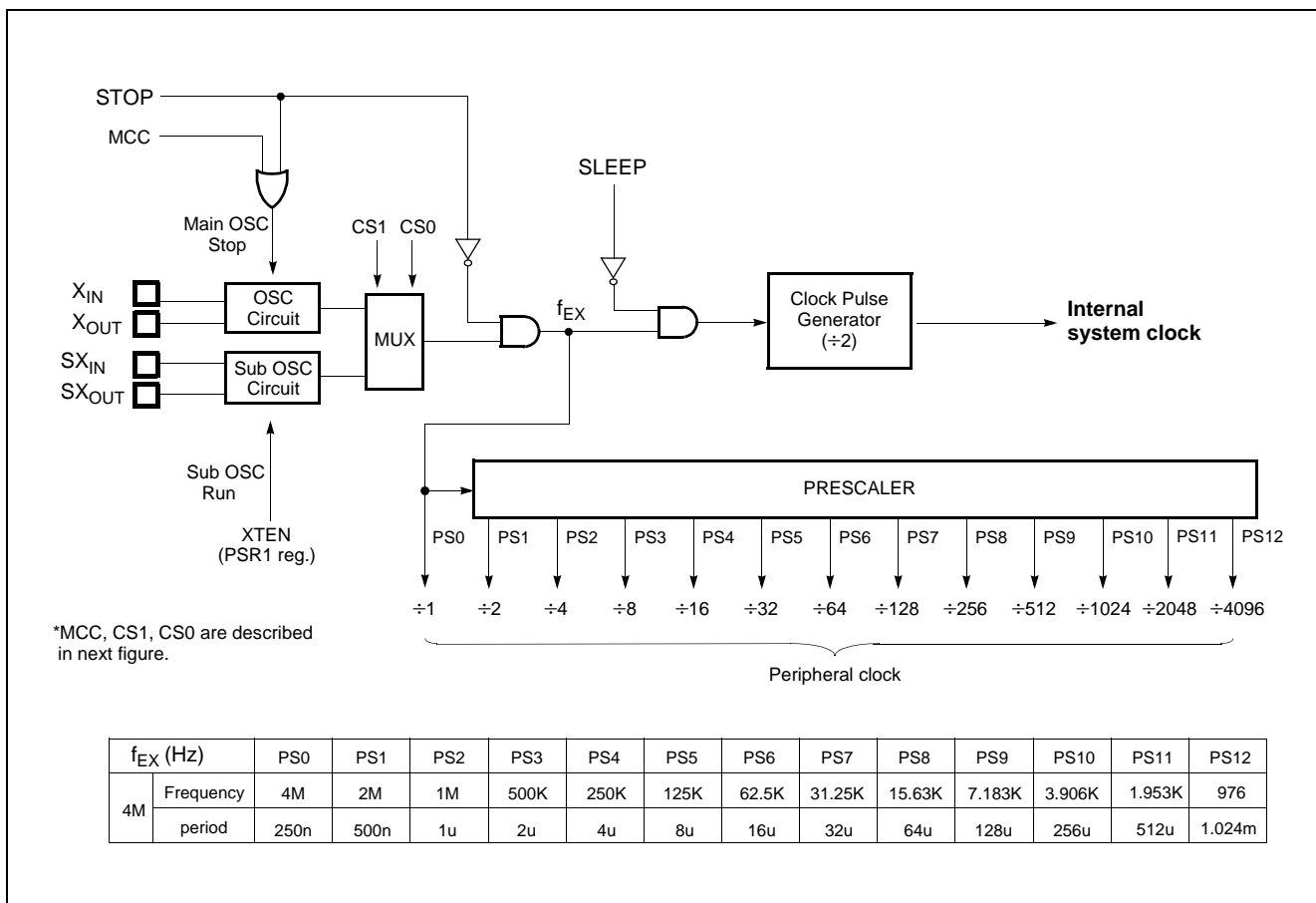

Figure 10-1 Block Diagram of Clock Generator

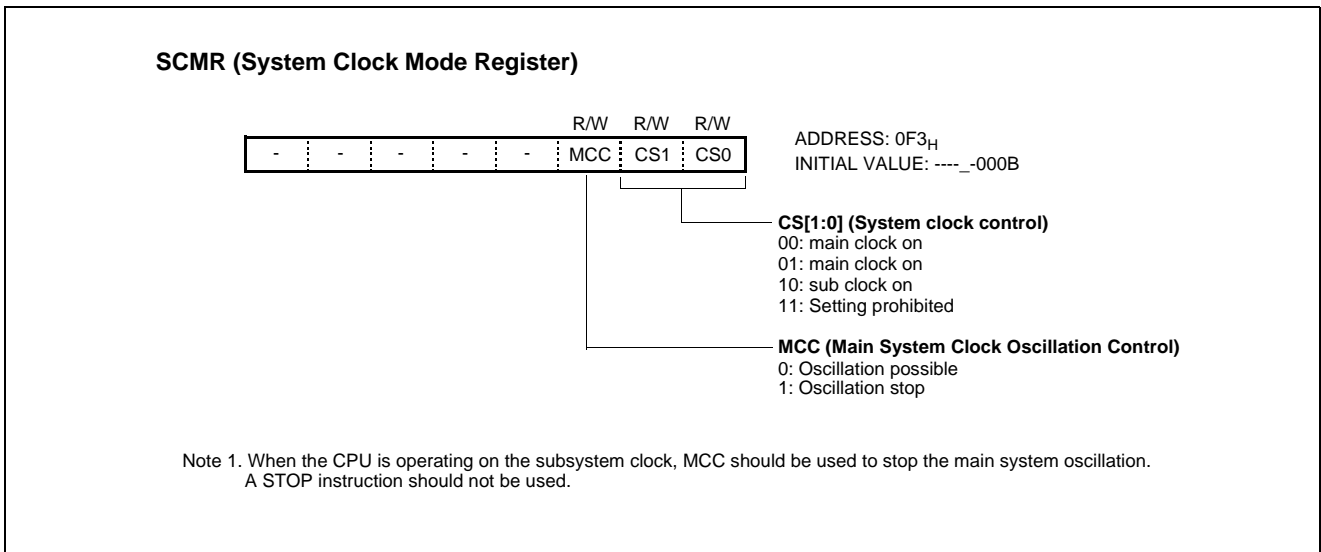

Figure 10-2 System Clock Mode Registers

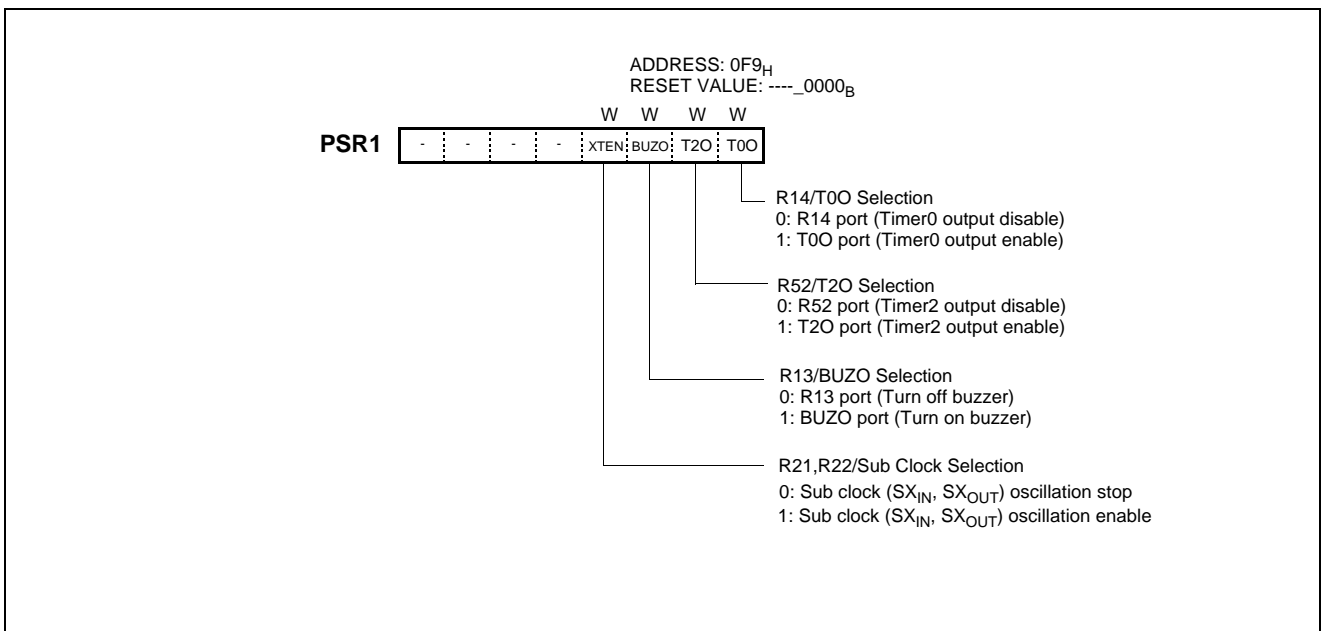

Figure 10-3 Port Selection Register PSR1

11. BASIC INTERVAL TIMER

The MC80F0424/0432/0448 has one 8-bit Basic Interval Timer that is free-run and can not stop. Block diagram is shown in Figure 11-1. In addition, the Basic Interval Timer generates the time base for watchdog timer counting. It also provides a Basic interval timer interrupt (BITIF).

The 8-bit Basic interval timer register (BITR) is increased every internal count pulse which is divided by prescaler. Since prescaler has divided ratio by 8 to 1024, the count rate is 1/8 to 1/1024 of the oscillator frequency. As the count overflow from FFH to 00H, this overflow causes the interrupt to be generated. The Basic Interval Timer is controlled by the clock control register (CKCTRL) shown in Figure 10-2.

When write "1" to bit BTCL of CKCTRL, BITR register is cleared to "0" and restart to count-up. The bit BTCL becomes "0"

after one machine cycle by hardware.

If the STOP instruction executed after writing "1" to bit RCWDT of CKCTRL, it goes into the internal RC oscillated watchdog timer mode. In this mode, all of the block is halted except the internal RC oscillator, Basic Interval Timer and RC Watchdog Timer. More detail informations are explained in Power Saving Function. The bit WDTON decides Watchdog Timer or the normal 7-bit timer.

Source clock can be selected by lower 3 bits of CKCTRL.

BITR and CKCTRL are located at same address, and address 0F2_H is read as a BITR, and written to CKCTRL.

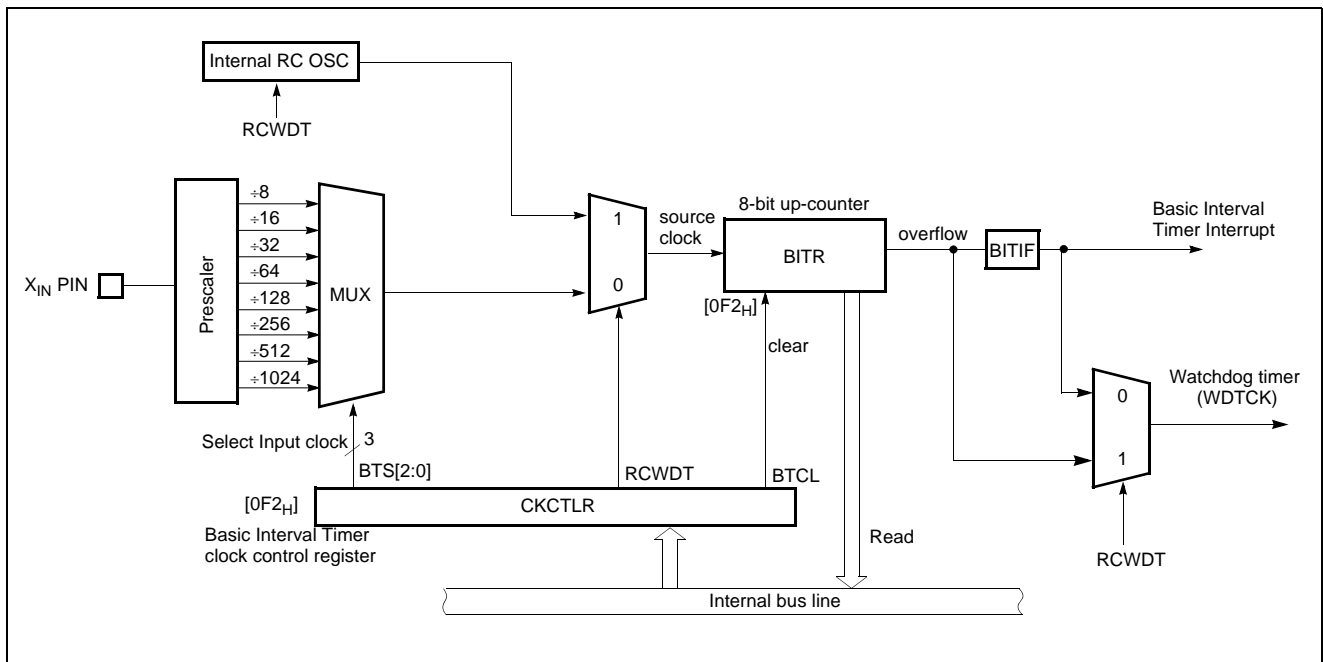

Figure 11-1 Block Diagram of Basic Interval Timer

CKCTRL [2:0]	Source clock	Interrupt (overflow) Period (ms) @ f _{XIN} = 8MHz
000	f _{XIN} ÷ 8	0.256
001	f _{XIN} ÷ 16	0.512
010	f _{XIN} ÷ 32	1.024
011	f _{XIN} ÷ 64	2.048
100	f _{XIN} ÷ 128	4.096
101	f _{XIN} ÷ 256	8.192
110	f _{XIN} ÷ 512	16.384
111	f _{XIN} ÷ 1024	32.768

Table 11-1 Basic Interval Timer Interrupt Period

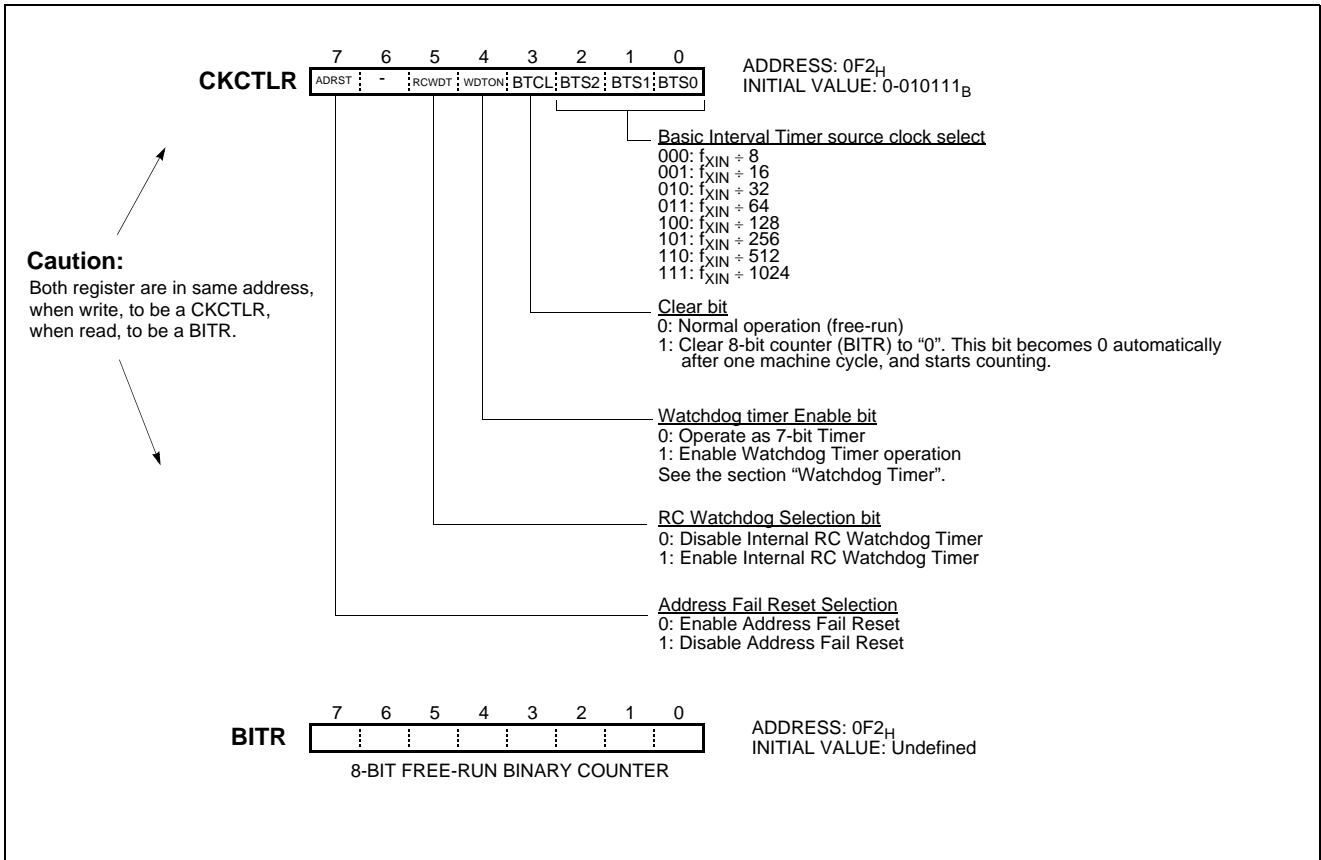

Figure 11-2 BITR: Basic Interval Timer Mode Register

Example 1:

Interrupt request flag is generated every 8.192ms at 4MHz.

```

:
LDM   CKCTLR, #1BH
SET1  BITE
EI
:
    
```

Example 2:

Interrupt request flag is generated every 8.192ms at 8MHz.

```

:
LDM   CKCTLR, #1CH
SET1  BITE
EI
:
    
```

12. WATCHDOG TIMER

The watchdog timer rapidly detects the CPU malfunction such as endless looping caused by noise or the like, and resumes the CPU to the normal state. The watchdog timer signal for detecting malfunction can be selected either a reset CPU or a interrupt request.

When the watchdog timer is not being used for malfunction detection, it can be used as a timer to generate an interrupt at fixed intervals.

The watchdog timer has two types of clock source. The first type is an on-chip RC oscillator which does not require any external components. This RC oscillator is separated from the external oscillator of the X_{IN} pin. It means that the watchdog timer will run, even if the clock on the X_{IN} pin of the device has been stopped, for example, by entering the STOP mode. The other type is a prescaler system clock.

The watchdog timer consists of 7-bit binary counter and the watchdog timer data register. When the value of 7-bit binary counter is equal to the lower 7 bits of WDTR, the interrupt request flag is generated. This can be used as Watchdog timer interrupt or reset the CPU in accordance with the bit WDTON.

Note: Because the watchdog timer counter is enabled after clearing Basic Interval Timer, after the bit WDTON set to "1", maximum error of timer is depend on prescaler ratio of Basic Interval Timer. The 7-bit binary counter is cleared by setting WDTCL(bit7 of WDTR) and the WDTCL is cleared automatically after 1 machine cycle.

The RC oscillated watchdog timer is activated by setting the bit RCWDT as shown below.

```
LDM      CKCTLR,#3FH; enable the RC-OSC WDT
LDM      WDTR,#0FFH ; set the WDT period
LDM      SSCR, #5AH ;ready for STOP mode
STOP     ; enter the STOP mode
NOP
NOP      ; RC-OSC WDT running
NOP
:
```

The RC-WDT oscillation period is vary with temperature, V_{DD} and process variations from part to part (approximately, 33~100uS). The following equation shows the RCWDT oscillated watchdog timer time-out.

$$T_{RCWDT} = CLK_{RCWDT} \times 2^8 \times WDTR + (CLK_{RCWDT} \times 2^8) / 2$$

where, $CLK_{RCWDT} = 33 \sim 100 \mu S$

In addition, this watchdog timer can be used as a simple 7-bit timer by interrupt WDTIF. The interval of watchdog timer interrupt is decided by Basic Interval Timer. Interval equation is as below.

$$T_{WDT} = (WDTR + 1) \times \text{Interval of BIT}$$

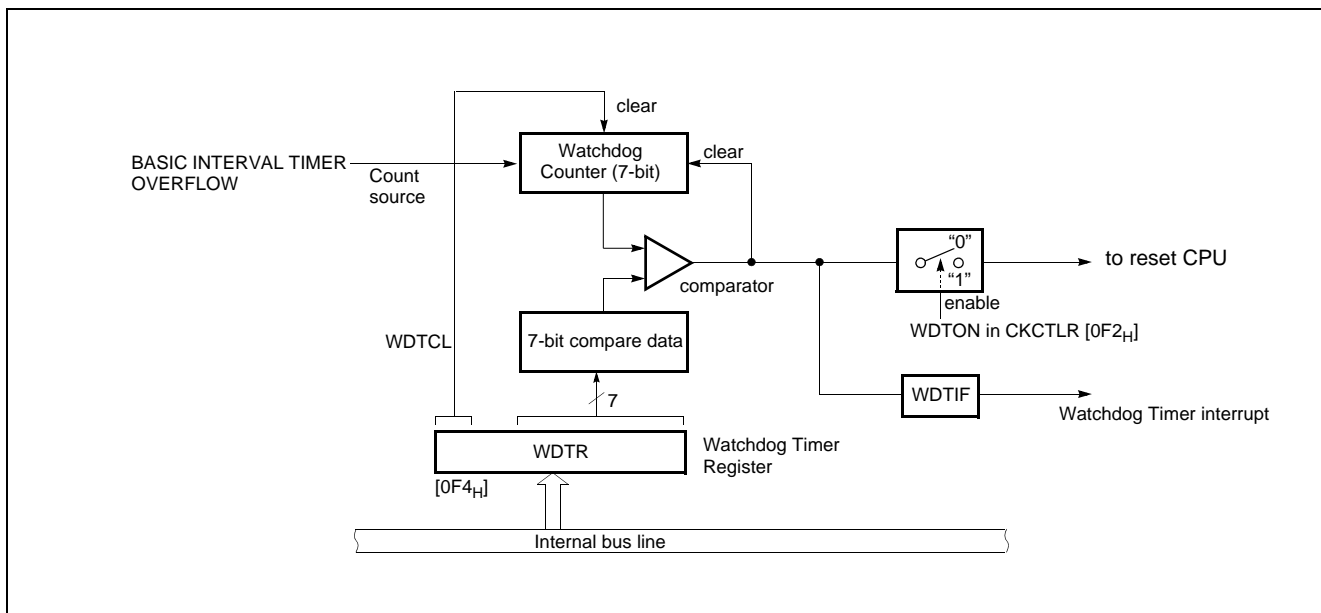

Figure 12-1 Block Diagram of Watchdog Timer

Watchdog Timer Control

Figure 12-2 shows the watchdog timer control register. The watchdog timer is automatically disabled after reset.

The CPU malfunction is detected during setting of the detection time, selecting of output, and clearing of the binary counter. Clearing the binary counter is repeated within the detection time.

If the malfunction occurs for any cause, the watchdog timer output will become active at the rising overflow from the binary

counters unless the binary counter is cleared. At this time, when WDTON=1, a reset is generated, which drives the RESET pin to low to reset the internal hardware. When WDTON=0, a watchdog timer interrupt (WDTIF) is generated. The WDTON bit is in register CLKCTLR.

The watchdog timer temporarily stops counting in the STOP mode, and when the STOP mode is released, it automatically restarts (continues counting).

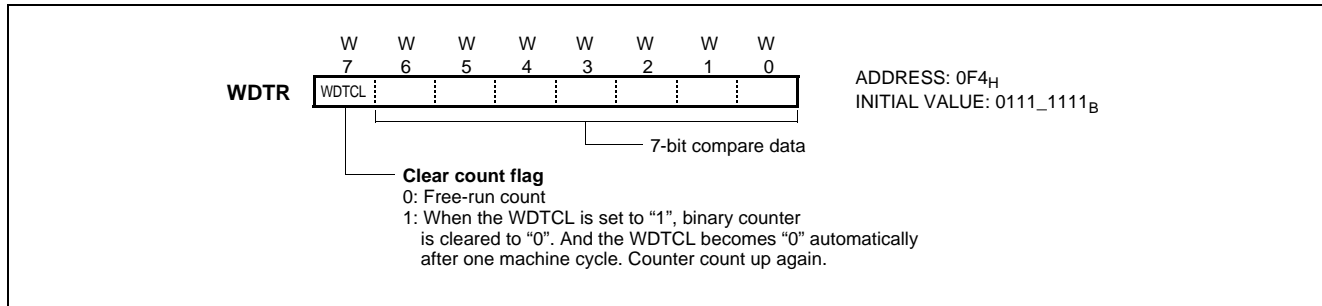

Figure 12-2 WDTTR: Watchdog Timer Control Register

Example: Sets the watchdog timer detection time to 1 sec. at 4.194304MHz

```

LDM    CKCTLR, #3FH           ; Select 1/1024 clock source, WDTON ← 1, Clear Counter
LDM    WDTTR, #08FH

Within WDT detection time
:
:
:
:
LDM    WDTTR, #08FH           ; Clear counter
:
:
:
:
Within WDT detection time
:
:
:
:
LDM    WDTTR, #08FH           ; Clear counter

```

Enable and Disable Watchdog

Watchdog timer is enabled by setting WDTON (bit 4 in CKCTLR) to "1". WDTON is initialized to "0" during reset and it should be set to "1" to operate after reset is released.

Example: Enables watchdog timer for Reset

```

:
LDM    CKCTLR, #xxx1_xxxxB; WDTON ← 1
:
:

```

The watchdog timer is disabled by clearing bit 4 (WDTON) of CKCTLR. The watchdog timer is halted in STOP mode and restarts automatically after STOP mode is released.

Watchdog Timer Interrupt

The watchdog timer can be also used as a simple 7-bit timer by clearing bit4 of CKCTLR to "0". The interval of watchdog timer interrupt is decided by Basic Interval Timer. Interval equation is shown as below.

$$T_{WDT} = (WDTTR + 1) \times \text{Interval of BIT}$$

The stack pointer (SP) should be initialized before using the watchdog timer output as an interrupt source.

Example: 7-bit timer interrupt set up.

```

LDM    CKCTLR, #xxx0_xxxxB; WDTON ← 0
LDM    WDTTR, #8FH       ; WDTCL ← 1
:

```

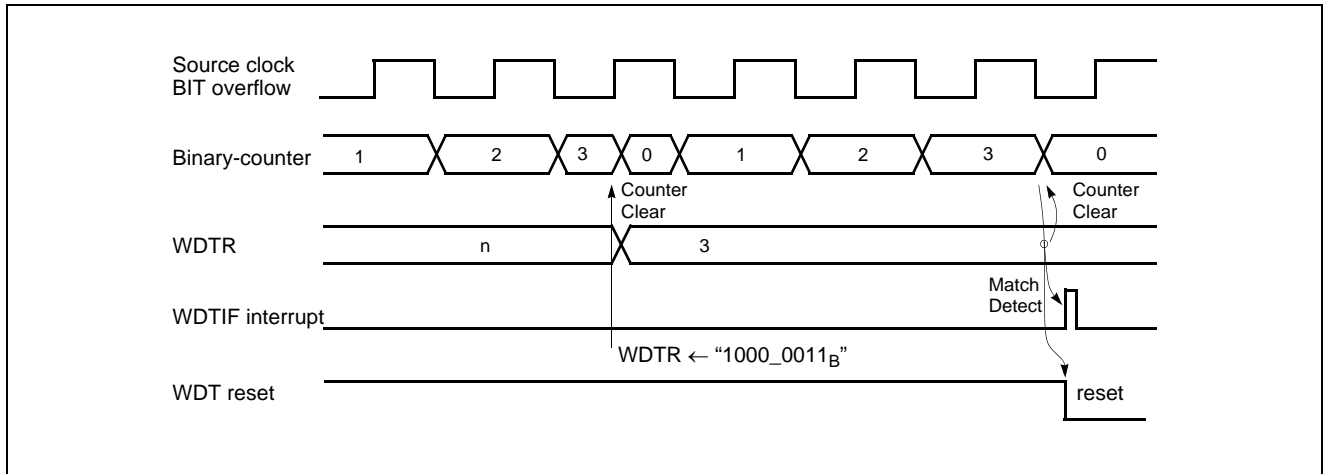

Figure 12-3 Watchdog timer Timing

If the watchdog timer output becomes active, a reset is generated, which drives the RESET pin low to reset the internal hardware. The main clock oscillator also turns on when a watchdog timer

reset is generated in sub clock mode. The IFWDT bit of IFR register is set when watchdog timer interrupt is generated. (Refer to Figure 12-4)

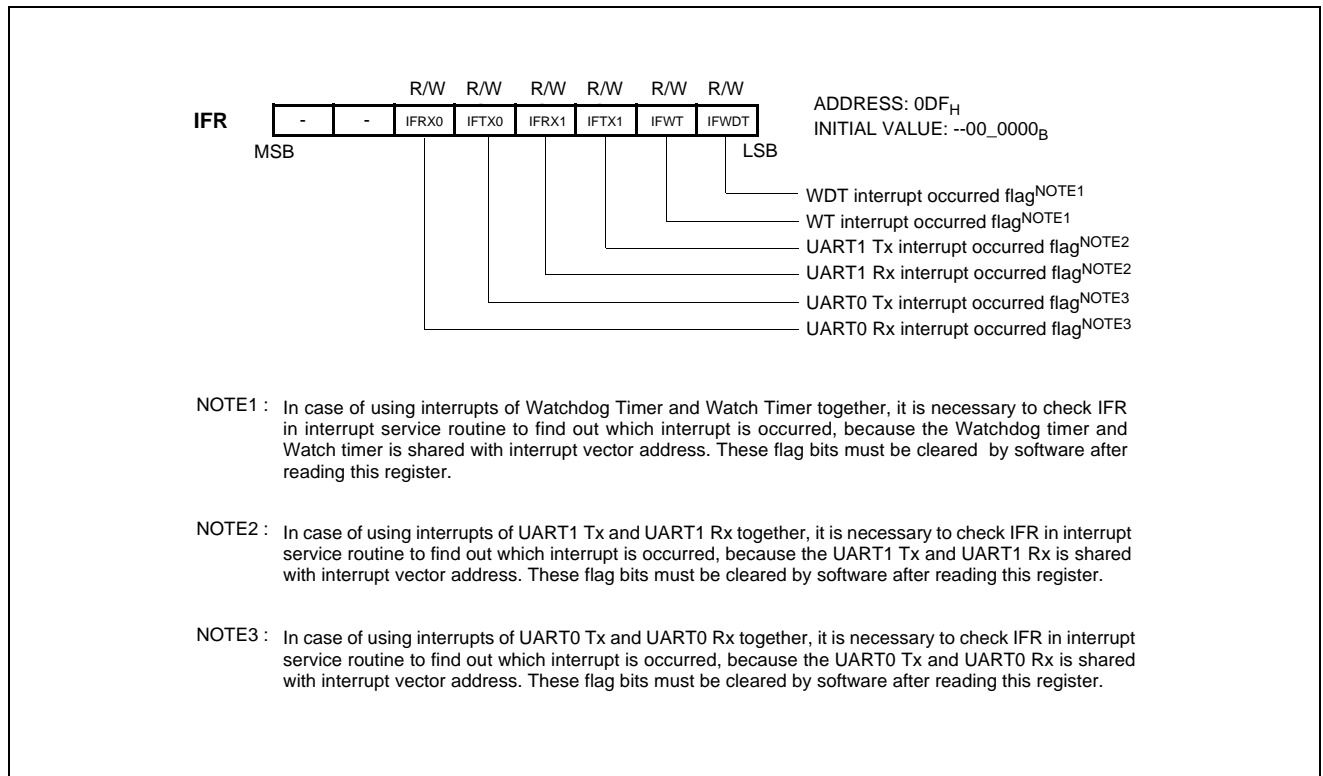

Figure 12-4 IFR : Interrupt Flag Register

13. WATCH TIMER

The watch timer generates interrupt for watch operation. The watch timer consists of the clock selector, 15-bit binary counter, interval selector and watch timer mode register. It is a multi-purpose timer. It is generally used for watch design.

The bit 0,1 of WTMR select the clock source of watch timer among sub-clock(32.768kHz), $f_{XIN} \div 2$, $f_{XIN} \div 128$ and main-clock(f_{XIN}). The f_{XIN} of main-clock is used usually for watch timer test, so generally it is not used for the clock source of watch timer. The $f_{XIN} \div 128$ of main-clock is used when the single clock system is organized. In $f_{XIN} \div 128$ clock source, if the CPU enters

into stop mode, the main-clock is stopped and then watch timer is also stopped. If the sub clock's oscillation is enabled by XTEN bit(PSR1 register), the watch timer by sub clock continues to operate even when the CPU is in the STOP mode. The watch timer counter can output with period of max 1 seconds at sub-clock. The bit 2, 3, 4 of WTMR select the interrupt interval divide ratio selection of watch timer among 16, 64, 256, 1024, 4096, 8192, 16384 or 32768.

The IFWT bit of IFR register is set when watch timer interrupt is generated. (Refer to Figure 12-4)

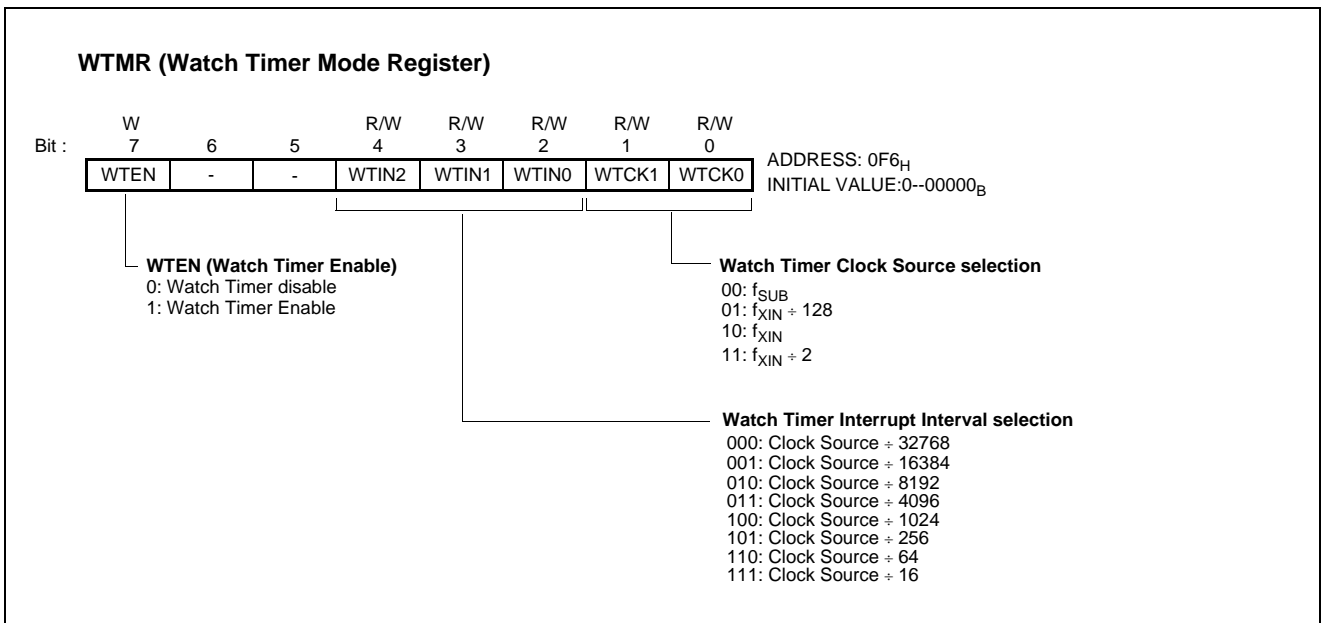

Figure 13-1 Watch Timer Mode Register

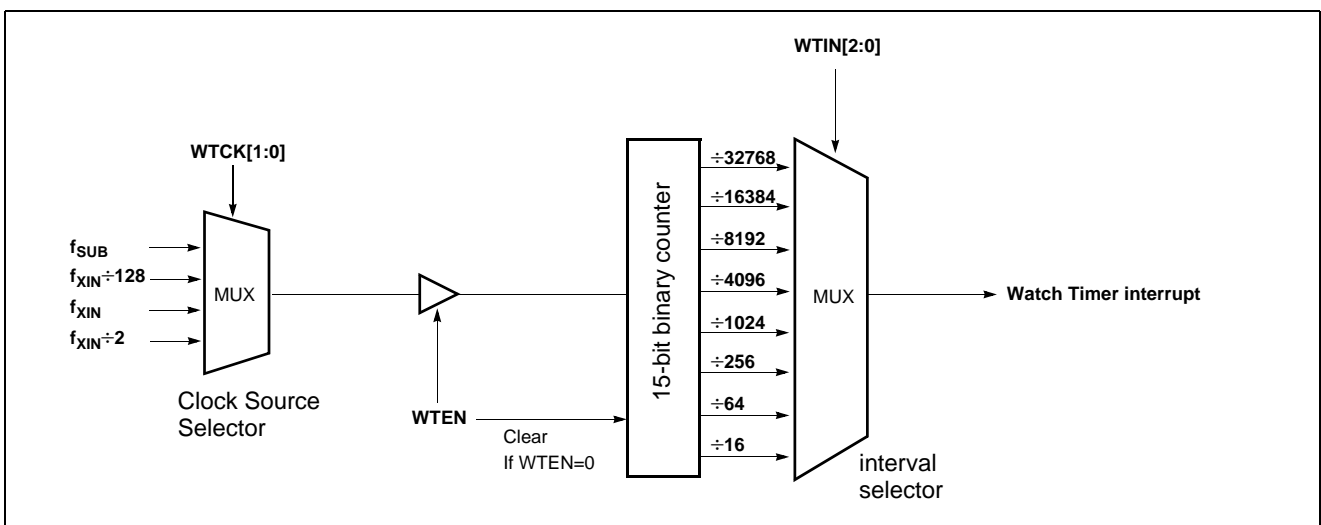

Figure 13-2 Watch Timer Block Diagram

14. TIMER/EVENT COUNTER

The MC80F0424/0432/0448 has five Timer/Counter registers. Each module can generate an interrupt to indicate that an event has occurred (i.e. timer match).

Timer 0 and Timer 1 are can be used either two 8-bit Timer/Counter or one 16-bit Timer/Counter with combine them. Also Timer 2 and Timer 3 are same. Timer 4 is 16-bit Timer/Counter. In the “timer” function, the register is increased every internal clock input. Thus, one can think of it as counting internal clock input. Since a least clock consists of 2 and most clock consists of 2048 oscillator periods, the count rate is 1/2 to 1/2048 of the oscillator frequency.

In the “counter” function, the register is increased in response to a 0-to-1 (rising edge) transition at its corresponding external input pin, EC0(Timer 0) or EC1(Timer 2).

In addition the “capture” function, the register is increased in response external or internal clock sources same with timer or

counter function. When external interrupt edge input, the count register is captured into capture data register CDRx.

It has seven operating modes: "8-bit timer/counter", "16-bit timer/counter", "8-bit capture", "16-bit capture", "8-bit compare output", "16-bit compare output" and "10-bit PWM" which are selected by bit in Timer mode register TMx as shown in Table 14-1, Table 14-2, Table 14-3, Figure 14-10, Figure 14-2 and Figure 14-3.

In 8/16 Timer mode, pin R14/T0O and R52/T2O can output Timer0 or Timer2 output by setting "1" respectively to bit T0O and T2O in PSR0 register.

In operation of Timer 2 and Timer 3, their operations are same as Timer 0 and Timer 1, respectively as shown in Table 14-2.

16BIT	CAP0	CAP1	PWM1E	T0CK [2:0]	T1CK [1:0]	PWM1O	TIMER 0	TIMER 1
0	0	0	0	XXX	XX	0	8-bit Timer	8-bit Timer
0	0	1	0	111	XX	0	8-bit Event counter	8-bit Capture
0	X ¹	0	0	XXX	XX	1	8-bit Capture	8-bit Compare Output
0	0	0	1	XXX	XX	1	8-bit Timer/Counter	10-bit PWM
1	0	0	0	XXX	11	0	16-bit Timer	
1	0	0	0	111	11	0	16-bit Event counter	
1	1	1	0	XXX	11	0	16-bit Capture	
1	0	0	0	XXX	11	1	16-bit Compare Output	

Table 14-1 Operating Modes of Timer 0, 1

1. X: The value "0" or "1" corresponding to user operation.

16BIT	CAP2	CAP3	PWM3E	T2CK [2:0]	T3CK [1:0]	PWM3O	TIMER 2	TIMER 3
0	0	0	0	XXX	XX	0	8-bit Timer	8-bit Timer
0	0	1	0	111	XX	0	8-bit Event counter	8-bit Capture
0	1	0	0	XXX	XX	1	8-bit Capture	8-bit Compare Output
0	X ¹	0	1	XXX	XX	1	8-bit Timer/Counter	10-bit PWM
1	0	0	0	XXX	11	0	16-bit Timer	
1	0	0	0	111	11	0	16-bit Event counter	
1	1	1	0	XXX	11	0	16-bit Capture	
1	0	0	0	XXX	11	1	16-bit Compare Output	

Table 14-2 Operating Modes of Timer 2, 3

1. X: The value "0" or "1" corresponding to user operation.

CAP4	T4CK[2:0]	TIMER 4
0	XXX ¹	16-bit Timer
1	XXX	16-bit Capture

Table 14-3 Operating Modes of Timer 4

1. X: The value "0" or "1" corresponding to user operation.

TM0

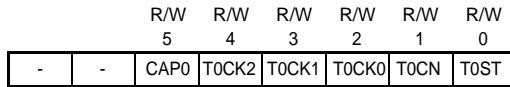

ADDRESS: 0D0_H
INITIAL VALUE: --000000_B

Bit Name	Bit Position	Description
CAP0	TM0.5	0: Timer/Counter mode 1: Capture mode selection flag
T0CK2	TM0.4	000: 8-bit Timer, Clock source is $f_{XIN} \div 2$
T0CK1	TM0.3	001: 8-bit Timer, Clock source is $f_{XIN} \div 4$
T0CK0	TM0.2	010: 8-bit Timer, Clock source is $f_{XIN} \div 8$ 011: 8-bit Timer, Clock source is $f_{XIN} \div 32$ 100: 8-bit Timer, Clock source is $f_{XIN} \div 128$ 101: 8-bit Timer, Clock source is $f_{XIN} \div 512$ 110: 8-bit Timer, Clock source is $f_{XIN} \div 2048$ 111: EC0 (External clock)
T0CN	TM0.1	0: Timer count pause 1: Timer count start
T0ST	TM0.0	0: When cleared, stop the counting. 1: When set, Timer 0 Count Register is cleared and start again.

TM1

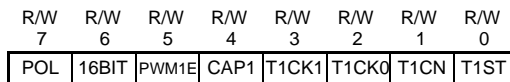

ADDRESS: 0D2_H
INITIAL VALUE: 00_H

Bit Name	Bit Position	Description
POL	TM1.7	0: PWM Duty Active Low 1: PWM Duty Active High
16BIT	TM1.6	0: 8-bit Mode 1: 16-bit Mode
PWM1E	TM1.5	0: Disable PWM 1: Enable PWM
CAP1	TM1.4	0: Timer/Counter mode 1: Capture mode selection flag
T1CK1	TM1.3	00: 8-bit Timer, Clock source is f_{XIN}
T1CK0	TM1.2	01: 8-bit Timer, Clock source is $f_{XIN} \div 2$ 10: 8-bit Timer, Clock source is $f_{XIN} \div 8$ 11: 8-bit Timer, Clock source is Using the Timer 0 Clock
T1CN	TM1.1	0: Timer count pause 1: Timer count start
T1ST	TM1.0	0: When cleared, stop the counting. 1: When set, Timer 0 Count Register is cleared and start again.

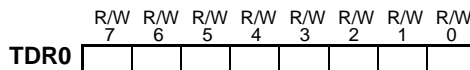

ADDRESS: 0D1_H
INITIAL VALUE: 0FF_H

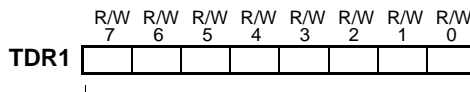

ADDRESS: 0D3_H
INITIAL VALUE: 0FF_H

Read: Count value read
Write: Compare data write

Figure 14-1 TM0, TM1 Registers

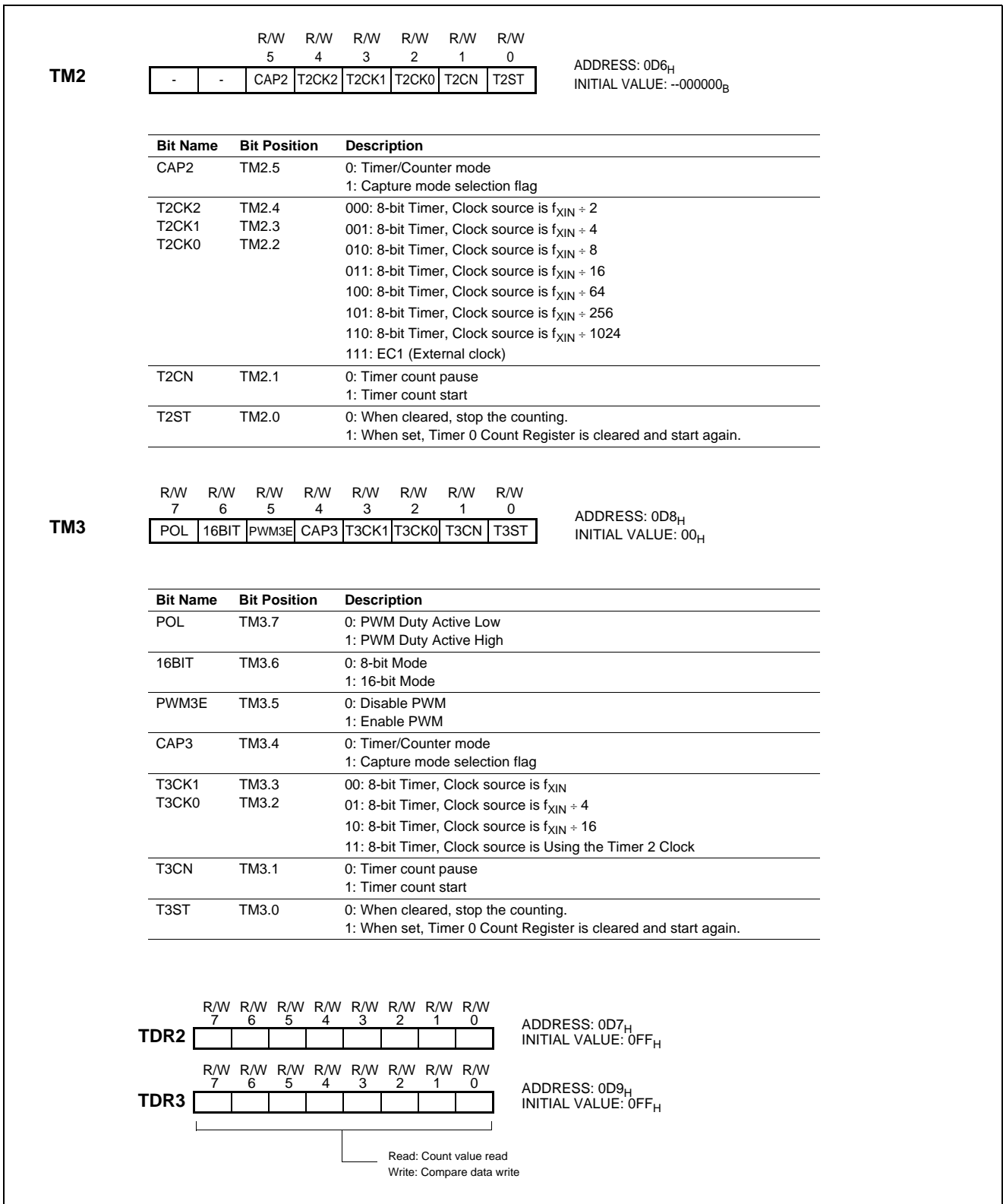

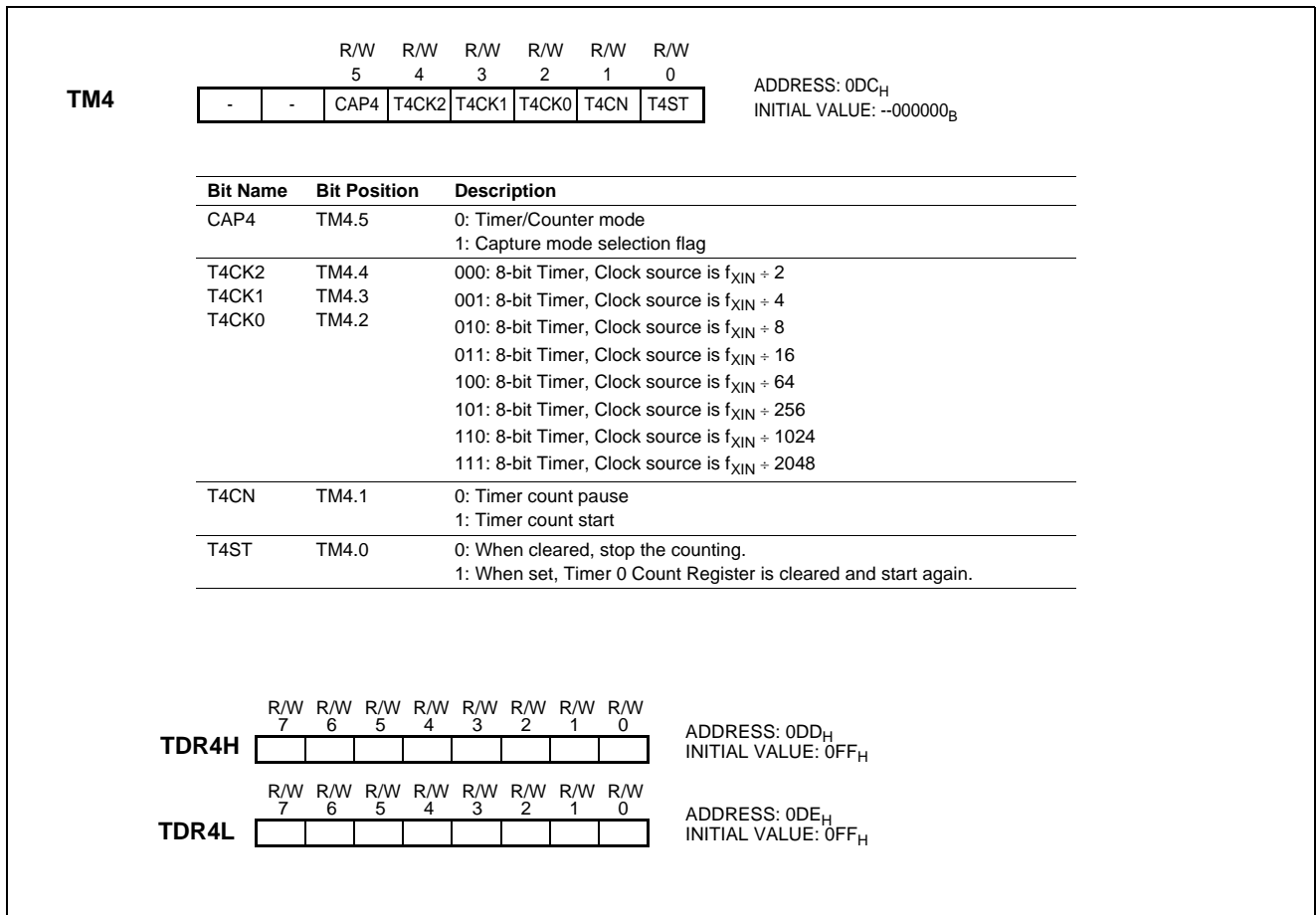

Figure 14-3 TM4 Registers

14.1 8-bit Timer / Counter Mode

The MC80F0424/0432/0448 has four 8-bit Timer/Counters, Timer 0, Timer 1, Timer 2, Timer 3. The Timer 0, Timer 1 are shown in Figure 14-4 and Timer 2, Timer 3 are shown in Figure 14-5.

The “timer” or “counter” function is selected by control registers TM0, TM1, TM2, TM3 as shown in Figure 14-1. To use as an 8-bit timer/counter mode, bit CAP0, CAP1, CAP2, or CAP3 of TMx should be cleared to “0” and 16BIT of TM1 or TM3 should

be cleared to “0”(Figure 14-4). These timers have each 8-bit count register and data register. The count register is increased by every internal or external clock input. The internal clock has a prescaler divide ratio option of 1, 2, 4, 8, 16, 32, 64, 128, 256, 512, 1024, 2048 or external clock (selected by control bits TxCK0, TxCK1, TxCK2 of register TMx).

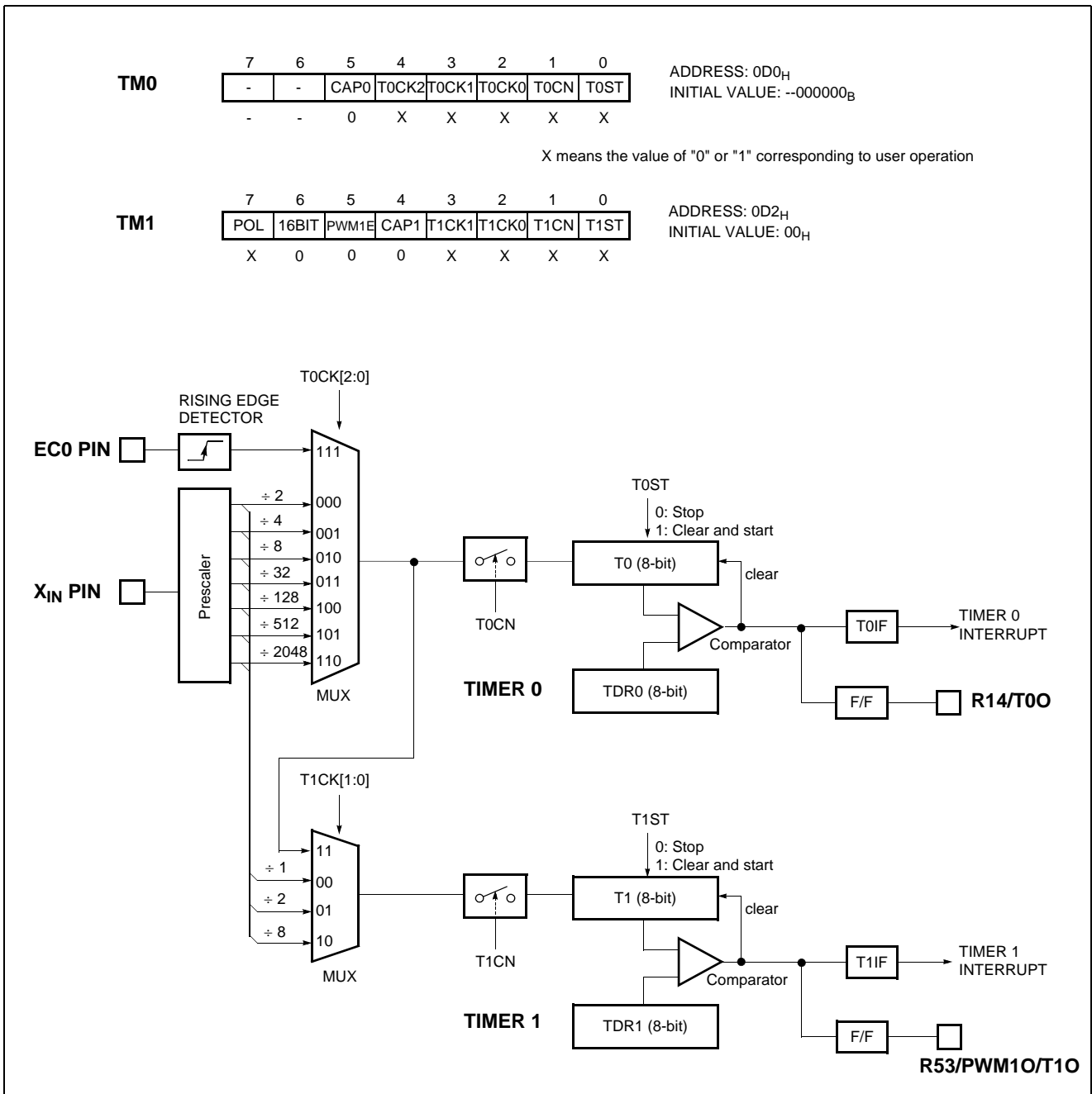
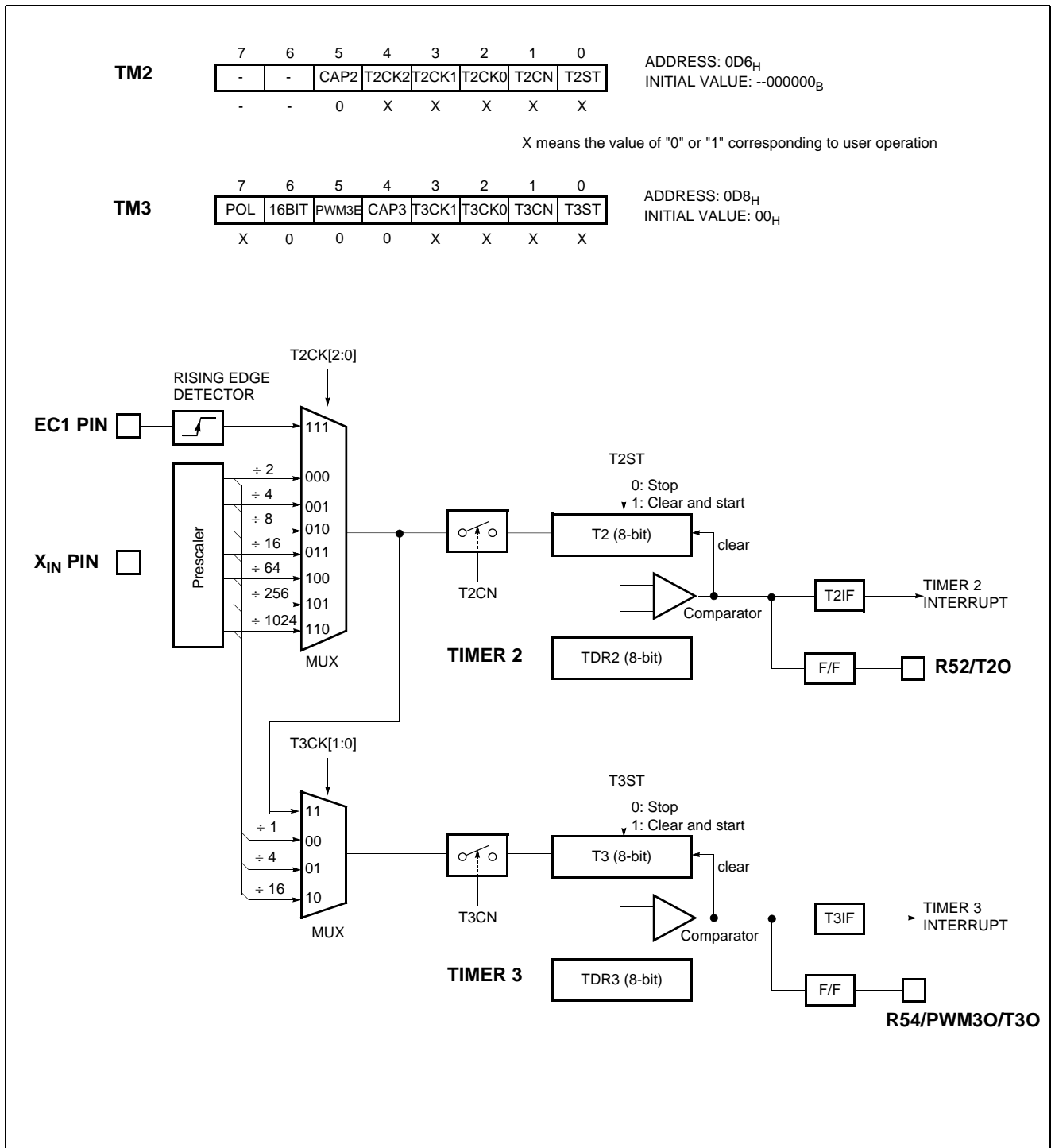

Figure 14-4 8-bit Timer/Counter 0, 1



Example 1:

Timer0 = 2ms 8-bit timer mode at 4MHz
 Timer1 = 0.5ms 8-bit timer mode at 4MHz
 Timer2 = 1ms 8-bit timer mode at 4MHz
 Timer3 = 1ms 8-bit timer mode at 4MHz

```
LDM   TDR0, #249
LDM   TDR1, #249
LDM   TDR2, #249
LDM   TDR3, #249
LDM   TM0, #0000_1111B
LDM   TM1, #0000_1011B
LDM   TM2, #0000_1111B
LDM   TM3, #0000_1011B
SET1  T0E
SET1  T1E
SET1  T2E
SET1  T3E
EI
```

Example 2:

Timer0 = 8-bit event counter mode
 Timer1 = 0.5ms 8-bit timer mode at 4MHz
 Timer2 = 8-bit event counter mode
 Timer3 = 1ms 8-bit timer mode at 4MHz

```
LDM   TDR0, #249
LDM   TDR1, #249
LDM   TDR2, #249
LDM   TDR3, #249
LDM   TM0, #0001_1111B
LDM   TM1, #0000_1011B
LDM   TM2, #0001_1111B
LDM   TM3, #0000_1011B
SET1  T0E
SET1  T1E
SET1  T2E
SET1  T3E
EI
```

These timers have each 8-bit count register and data register. The count register is increased by every internal or external clock input. The internal clock has a prescaler divide ratio option of 2, 4, 8, 32, 128, 512, 2048 selected by control bits T0CK[2:0] of register TM0 or 1, 2, 8 selected by control bits T1CK[1:0] of register TM1, or 2, 4, 8, 16, 64, 256, 1024 selected by control bits T2CK[2:0] of register TM2, or 1, 4, 16 selected by control bits T3CK[1:0] of register TM3. In the Timer 0, timer register T0 increases from 00_H until it matches TDR0 and then reset to 00_H. The match output of Timer 0 generates Timer 0 interrupt (latched in TOIF bit).

In counter function, the counter is increased every 0-to-1(1-to-0) (rising & falling edge) transition of EC0 pin. In order to use counter function, the bit EC0 of the Port Selection Register(PSR0.4) is set to "1". The Timer 0 can be used as a counter by pin EC0 input, but Timer 1 can not. Likewise, In order to use Timer2 as counter function, the bit EC1 of the Port Selection Register(PSR0.5) is set to "1". The Timer 2 can be used as a counter by pin EC1 input, but Timer 3 can not.

14.1.1 8-bit Timer Mode

In the timer mode, the internal clock is used for counting up. Thus, you can think of it as counting internal clock input. The contents of TDR_n are compared with the contents of up-counter, T_n. If match is found, a timer *n* interrupt (T_nIF) is generated and the up-counter is cleared to 0. Counting up is resumed after the up-counter is cleared.

As the value of TDR_n is changeable by software, time interval is set as you want.

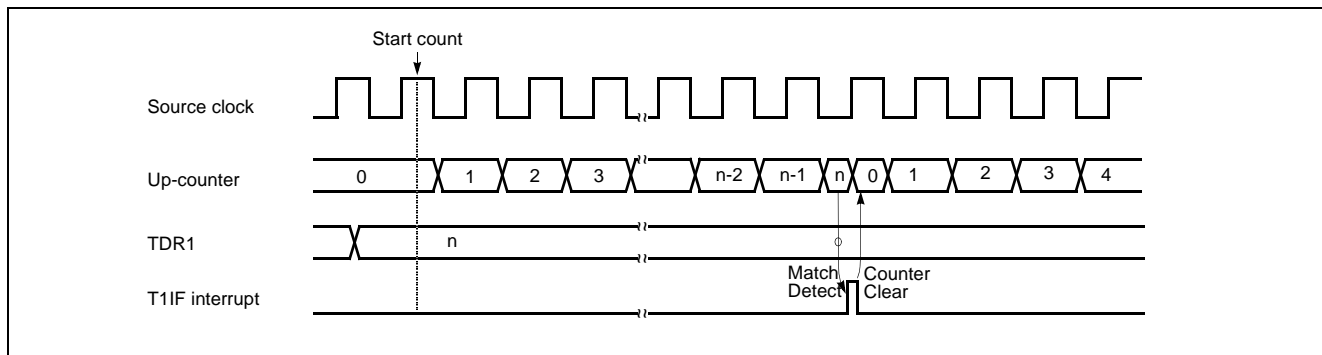

Figure 14-6 Timer Mode Timing Chart

Example: Make 1ms interrupt using by Timer0 at 4MHz

```

LDM    TM0,#0FH    ; divide by 32
LDM    TDR0,#124  ; 8us x (124+1)= 1ms
SET1   T0E        ; Enable Timer 0 Interrupt
EI     ; Enable Master Interrupt
    
```

When $\left[\begin{array}{l} TM0 = 0000\ 1111_B \text{ (8-bit Timer mode, Prescaler divide ratio} = 32) \\ TDR0 = 124_D = 7C_H \\ f_{XIN} = 4 \text{ MHz} \end{array} \right.$

$$\text{INTERRUPT PERIOD} = \frac{1}{4 \times 10^6 \text{ Hz}} \times 32 \times (124+1) = 1 \text{ ms}$$

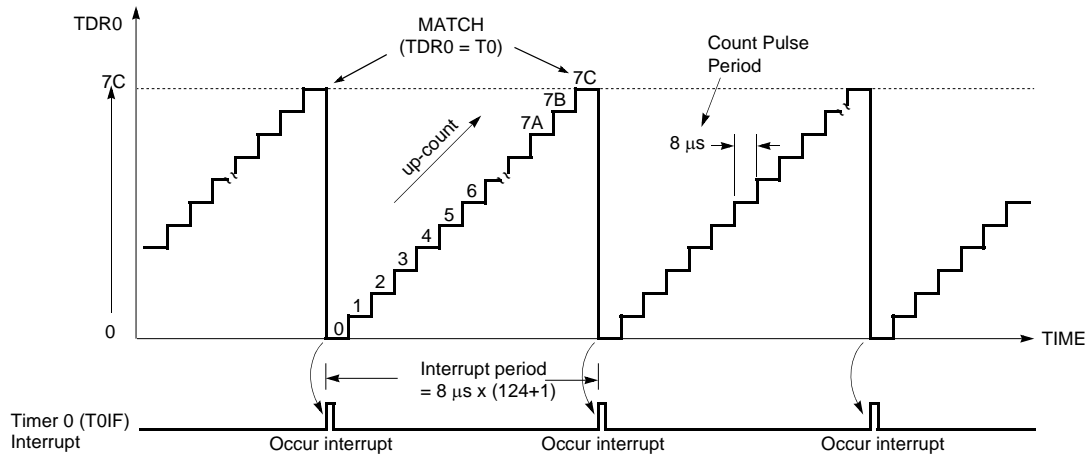

Figure 14-7 Timer Count Example

14.1.2 8-bit Event Counter Mode

In this mode, counting up is started by an external trigger. This trigger means rising edge of the EC0 or EC1 pin input. Source clock is used as an internal clock selected with timer mode register TM0 or TM2. The contents of timer data register TDRn (n = 0,1,2,3) are compared with the contents of the up-counter Tn. If a match is found, an timer interrupt request flag TnIF is generated, and the counter is cleared to "0". The counter is restart and count up continuously by every rising edge of the EC0 or EC1 pin input. The maximum frequency applied to the EC0 or EC1 pin is $f_{XIN}/2$ [Hz].

In order to use event counter function, the bit 4, 5 of the Port Selection Register PSR0(address 0F8H) is required to be set to "1".

After reset, the value of timer data register TDRn is initialized to "0". The interval period of Timer is calculated as below equation.

$$\text{Period (sec)} = \frac{1}{f_{XIN}} \times 2 \times \text{Divide Ratio} \times (TDRn+1)$$

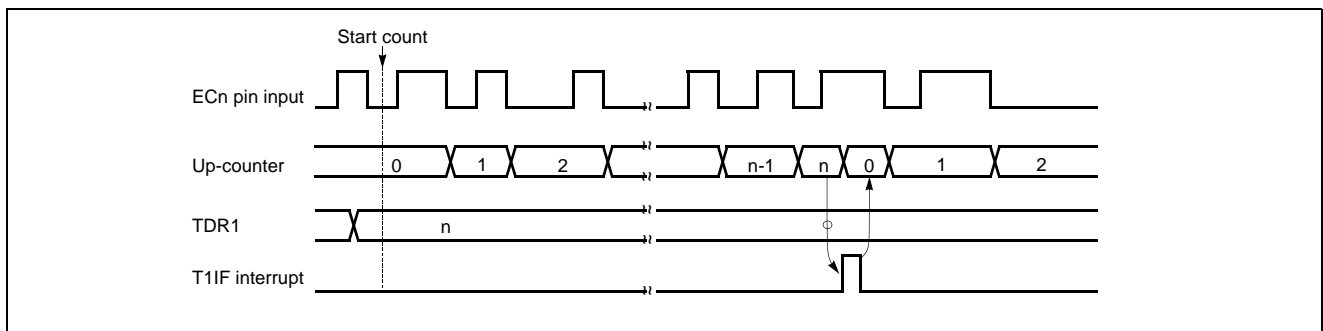

Figure 14-8 Event Counter Mode Timing Chart

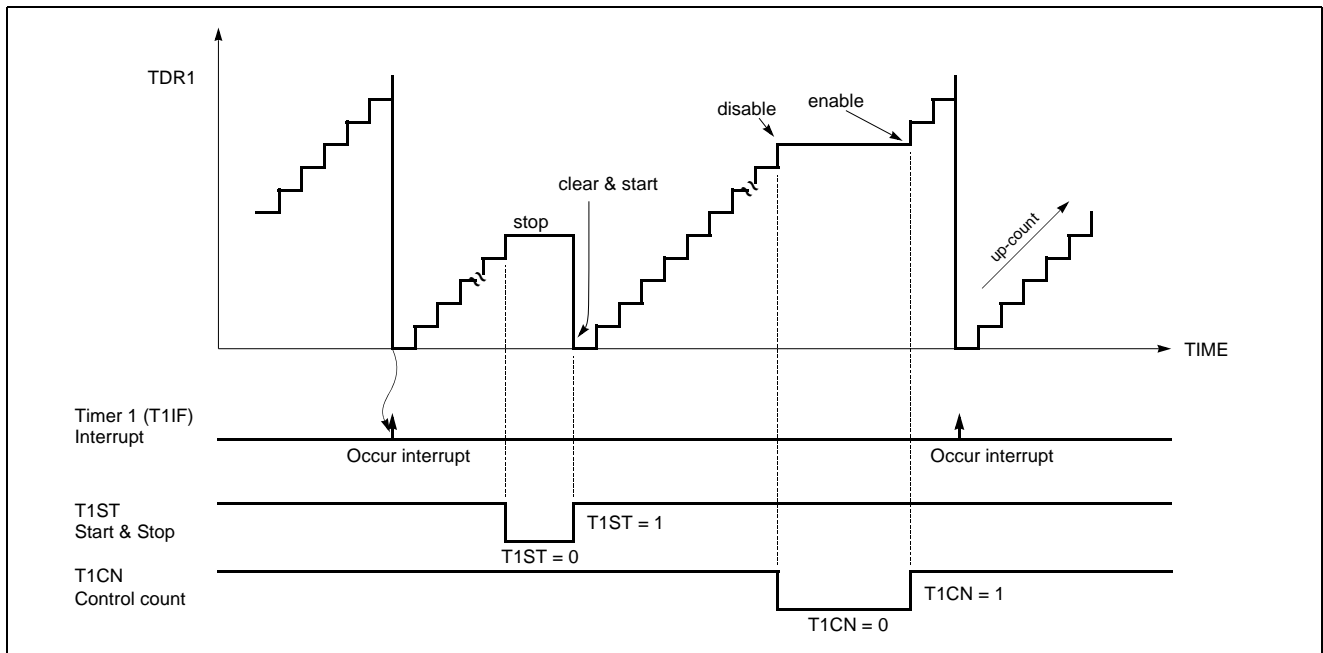

Figure 14-9 Count Operation of Timer / Event counter

14.2 16-bit Timer / Counter Mode

The Timer register is being run with all 16 bits. A 16-bit timer/counter register T0, T1 are incremented from 0000_H until it matches TDR0, TDR1 and then resets to 0000_H. The match output generates Timer 0 interrupt.

The clock source of the Timer 0 is selected either internal or external clock by bit T0CK[2:0]. In 16-bit mode, the bits T1CK[1:0] and 16BIT of TM1 should be set to "1" respectively as shown in Figure 14-10.

Likewise, A 16-bit timer/counter register T2, T3 are incremented from 0000_H until it matches TDR2, TDR3 and then resets to 0000_H. The match output generates Timer 2 interrupt.

The clock source of the Timer 2 is selected either internal or external clock by bit T2CK[2:0]. In 16-bit mode, the bits

T3CK[1:0] and 16BIT of TM3 should be set to "1" respectively as shown in Figure 14-11.

Even if the Timer 0 (including Timer 1) is used as a 16-bit timer, the Timer 2 and Timer 3 can still be used as either two 8-bit timer or one 16-bit timer by setting the TM2. Reversely, even if the Timer 2 (including Timer 3) is used as a 16-bit timer, the Timer 0 and Timer 1 can still be used as 8-bit timer independently.

A 16-bit timer/counter 4 register T4H, T4L are increased from 0000_H until it matches TDR4H, TDR4L and then resets to 0000_H. The match output generates Timer 4 interrupt. Timer/Counter 4 is 16 bit mode as shown in Figure 14-12.

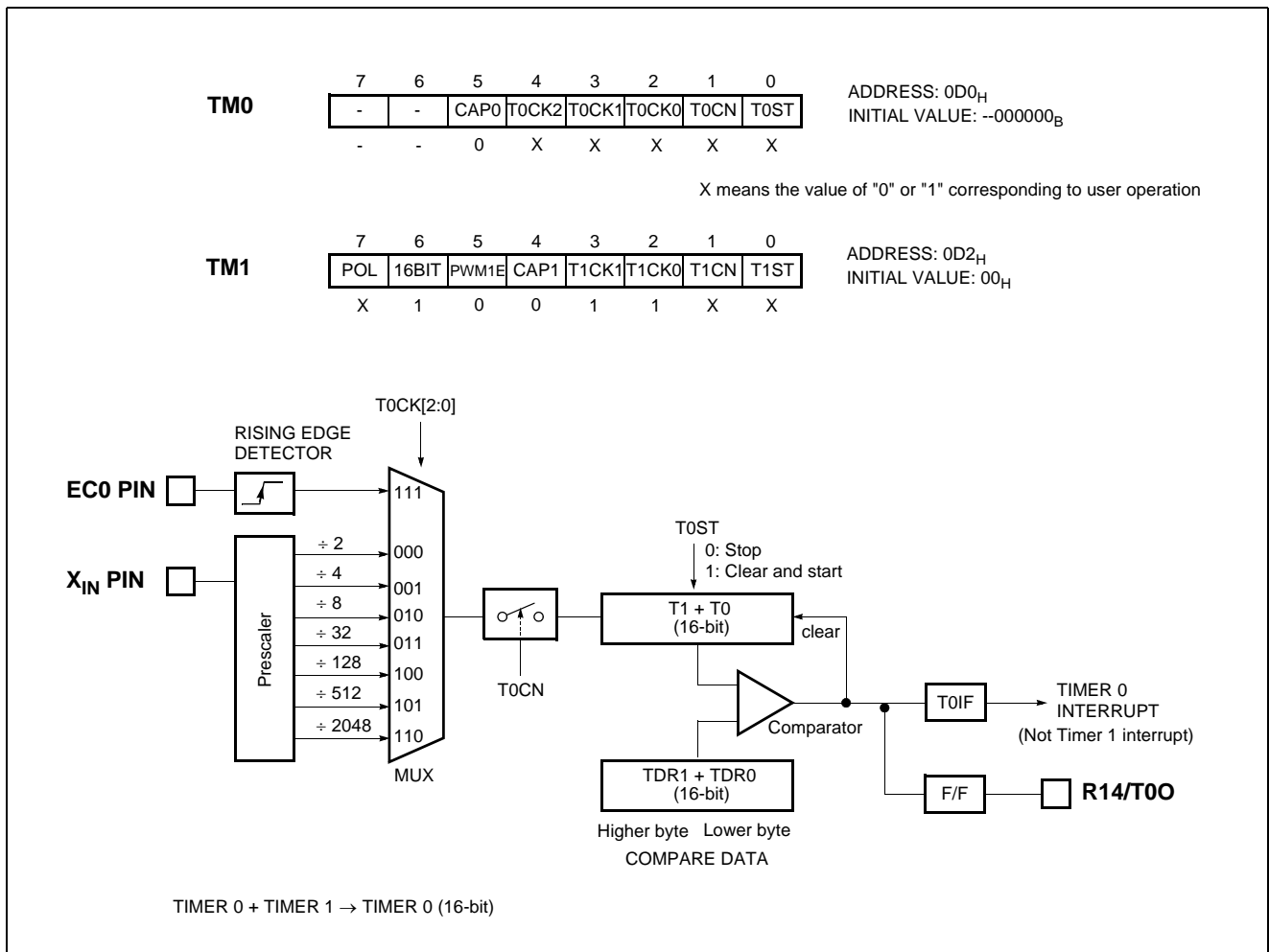

Figure 14-10 16-bit Timer/Counter for Timer 0, 1

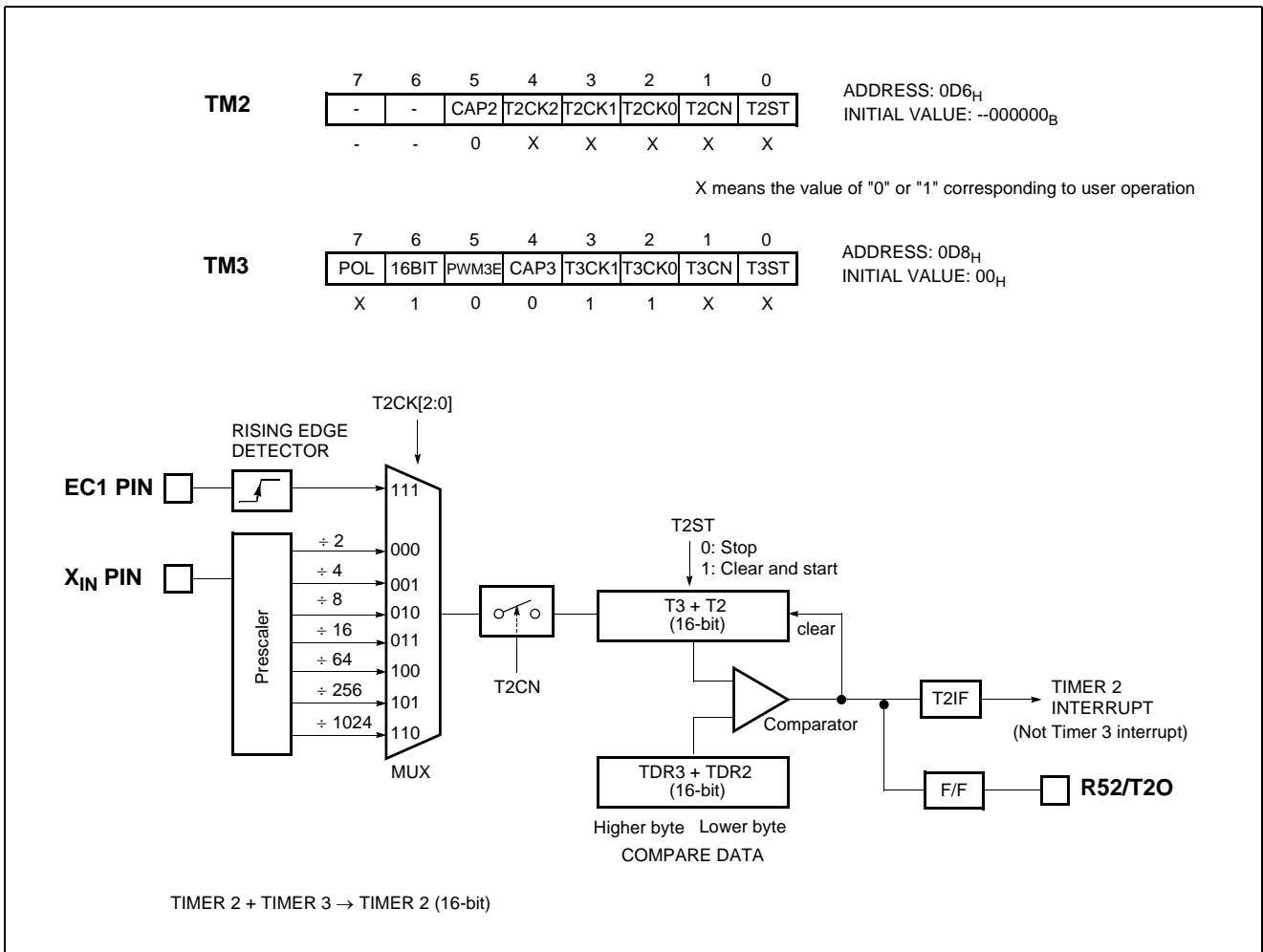

Figure 14-11 16-bit Timer/Counter for Timer 2, 3

14.3 8-bit Compare Output (16-bit)

The MC80F0424/0432/0448 has a function of Timer Compare Output. To pulse out, the timer match can go to port pin(T00, PWM10, T20, PWM30) as shown in Figure 14-4, Figure 14-5 and Figure 14-12. In this mode, the bit PWM10 and PWM30 of PSR0 register should be set to "1", and the bit PWM1E/PWM3E of timer1/timer3 mode register (TM1/TM3) should be set to "0".

These Compare output pins output the signal having a 50:50 duty square wave, and output frequency is same as below equation.

$$f_{COMP} = \frac{Oscillation\ Frequency}{2 \times Prescaler\ Value \times (TDR + 1)}$$

In addition, 16-bit Compare output mode is available, also.

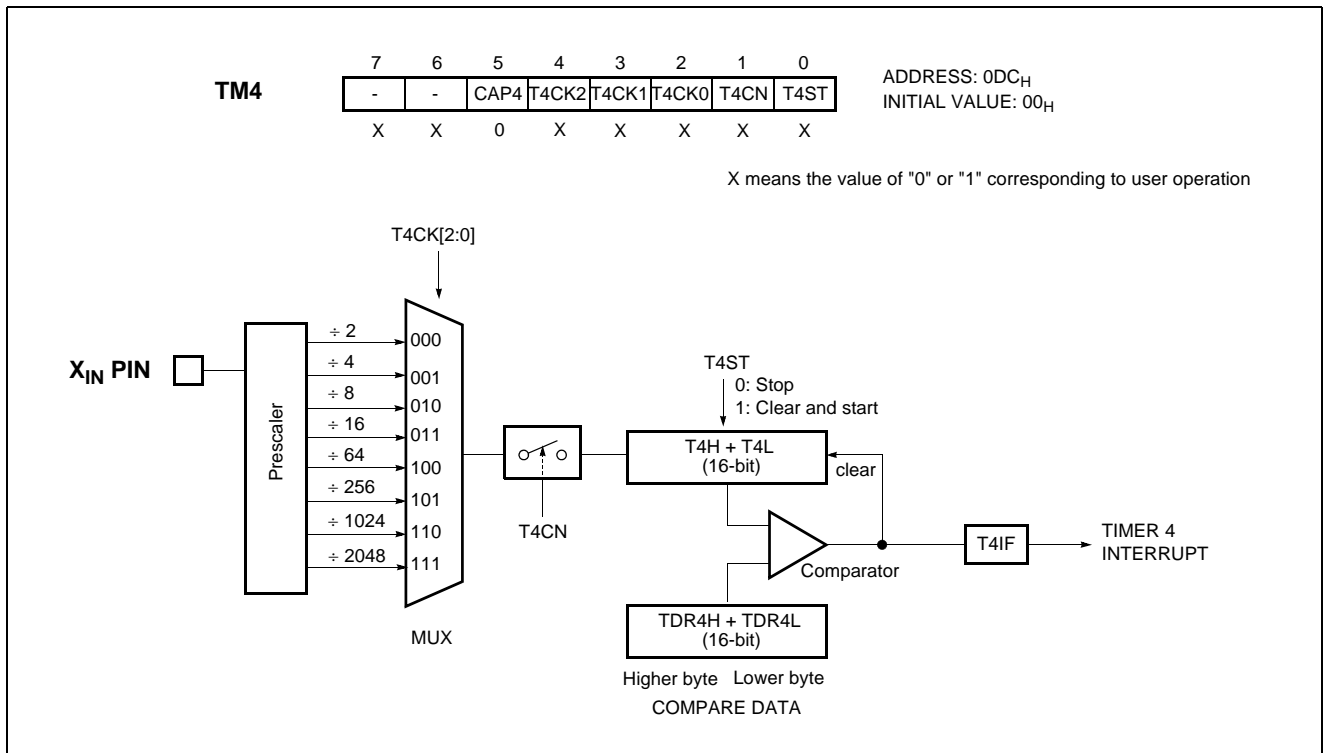

Figure 14-12 Timer 4 for only 16 bit mode

14.4 8-bit Capture Mode

The Timer 0 capture mode is set by bit CAP0 of timer mode register TM0 (bit CAP1 of timer mode register TM1 for Timer 1) as shown in Figure 14-13. Likewise, the Timer 2 capture mode is set by bit CAP2 of timer mode register TM2 (bit CAP3 of timer mode register TM3 for Timer 3) as shown in Figure 14-14.

The Timer/Counter register is increased in response internal or external input. This counting function is same with normal timer mode, and Timer interrupt is generated when timer register T0 (T1, T2, T3) increases and matches TDR0 (TDR1, TDR2, TDR3).

This timer interrupt in capture mode is very useful when the pulse width of captured signal is more wider than the maximum period of Timer.

For example, in Figure 14-16, the pulse width of captured signal is wider than the timer data value (FF_H) over 2 times. When external interrupt is occurred, the captured value (13_H) is more little

than wanted value. It can be obtained correct value by counting the number of timer overflow occurrence.

Timer/Counter still does the above, but with the added feature that a edge transition at external input INT_x pin causes the current value in the Timer x register (T0,T1,T2,T3), to be captured into registers CDR_x (CDR0, CDR1, CDR2, CDR3), respectively. After captured, Timer x register is cleared and restarts by hardware. It has three transition modes: "falling edge", "rising edge", "both edge" which are selected by interrupt edge selection register IEDS. Refer to "19.5 External Interrupt" on page 96. In addition, the transition at INT_n pin generate an interrupt.

Note: The CDR_n and TDR_n are in same address. In the capture mode, reading operation is read the CDR_n, not TDR_n because path is opened to the CDR_n.

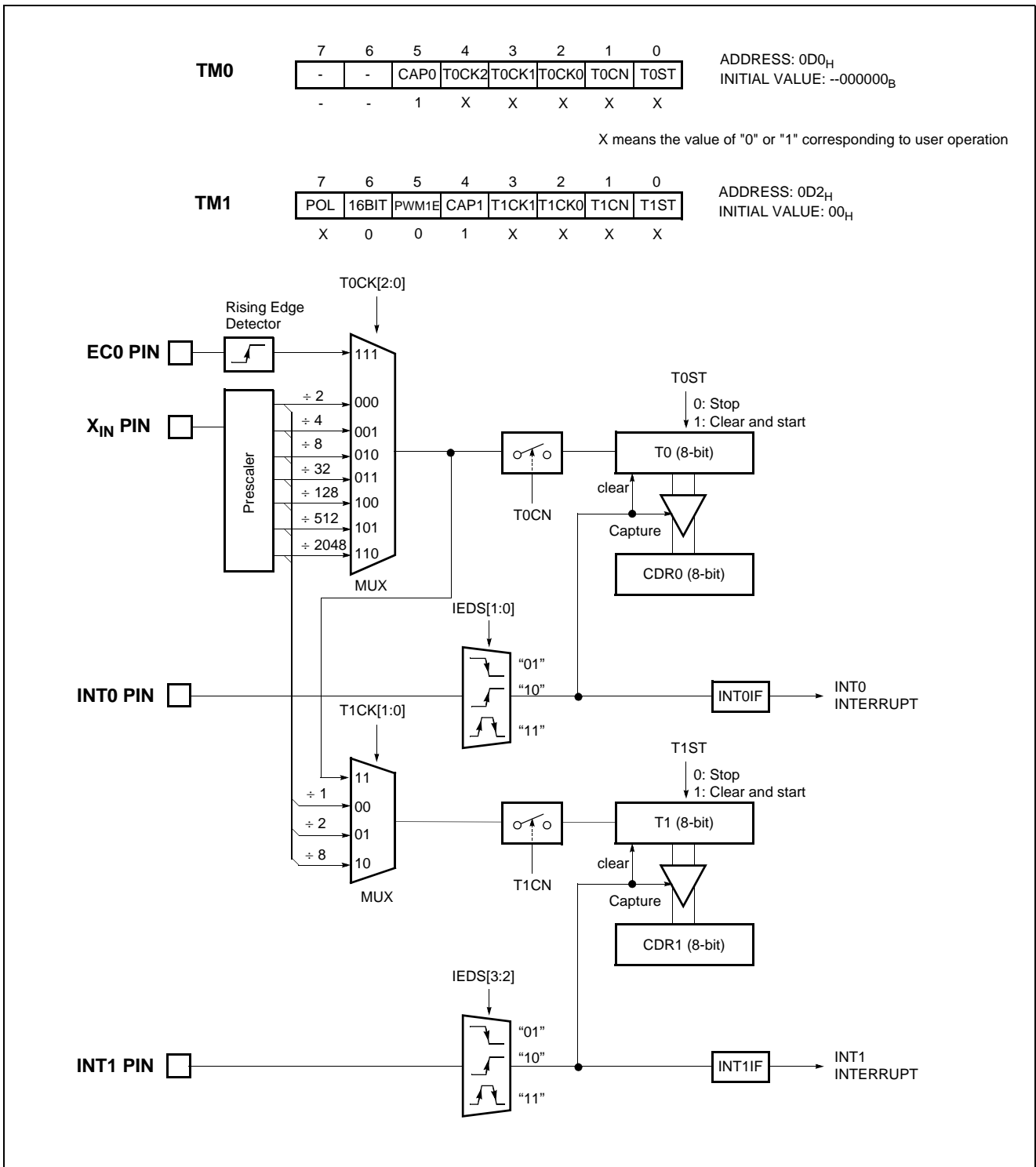

Figure 14-13 8-bit Capture Mode for Timer 0, 1

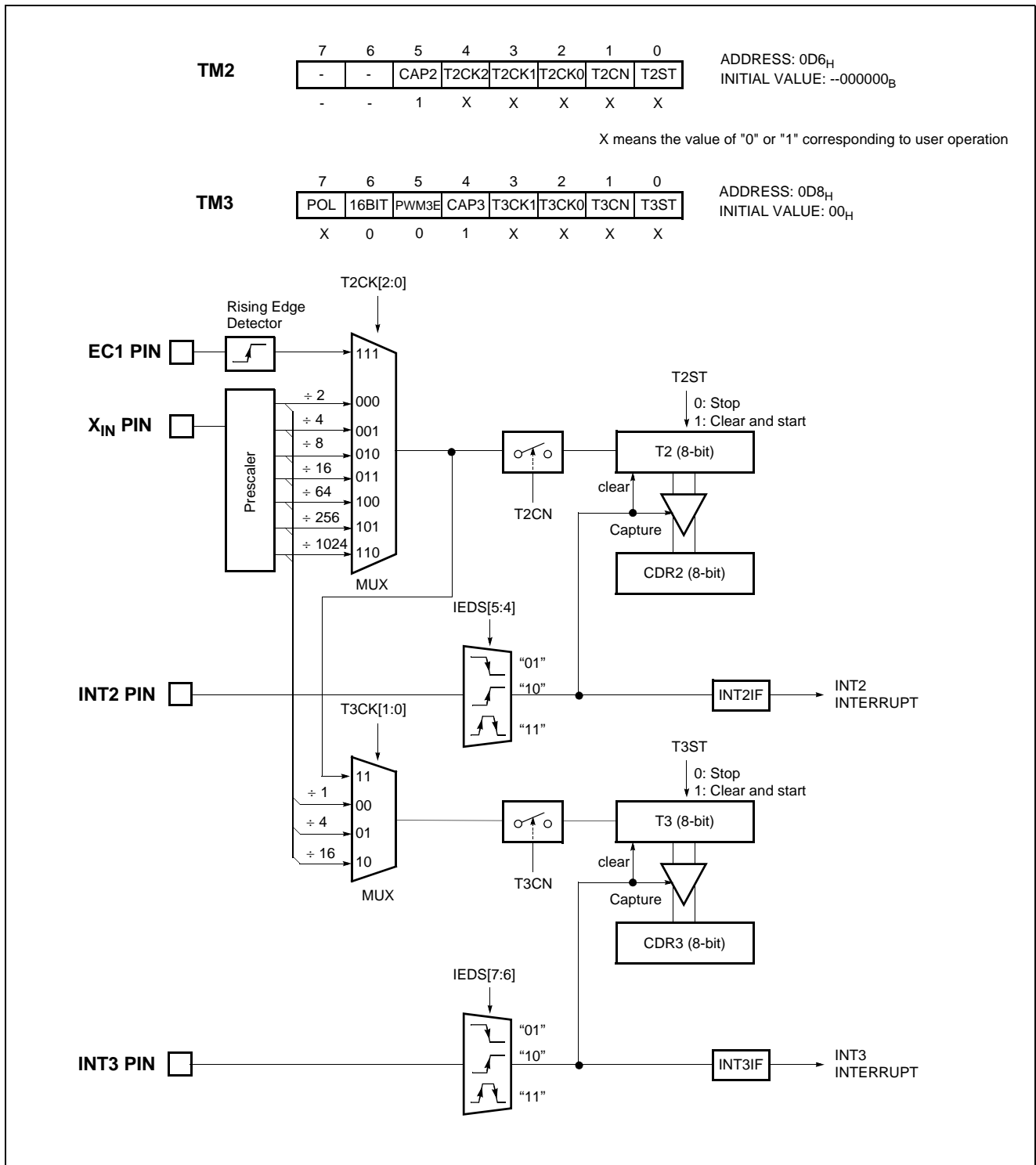

Figure 14-14 8-bit Capture Mode for Timer 2, 3

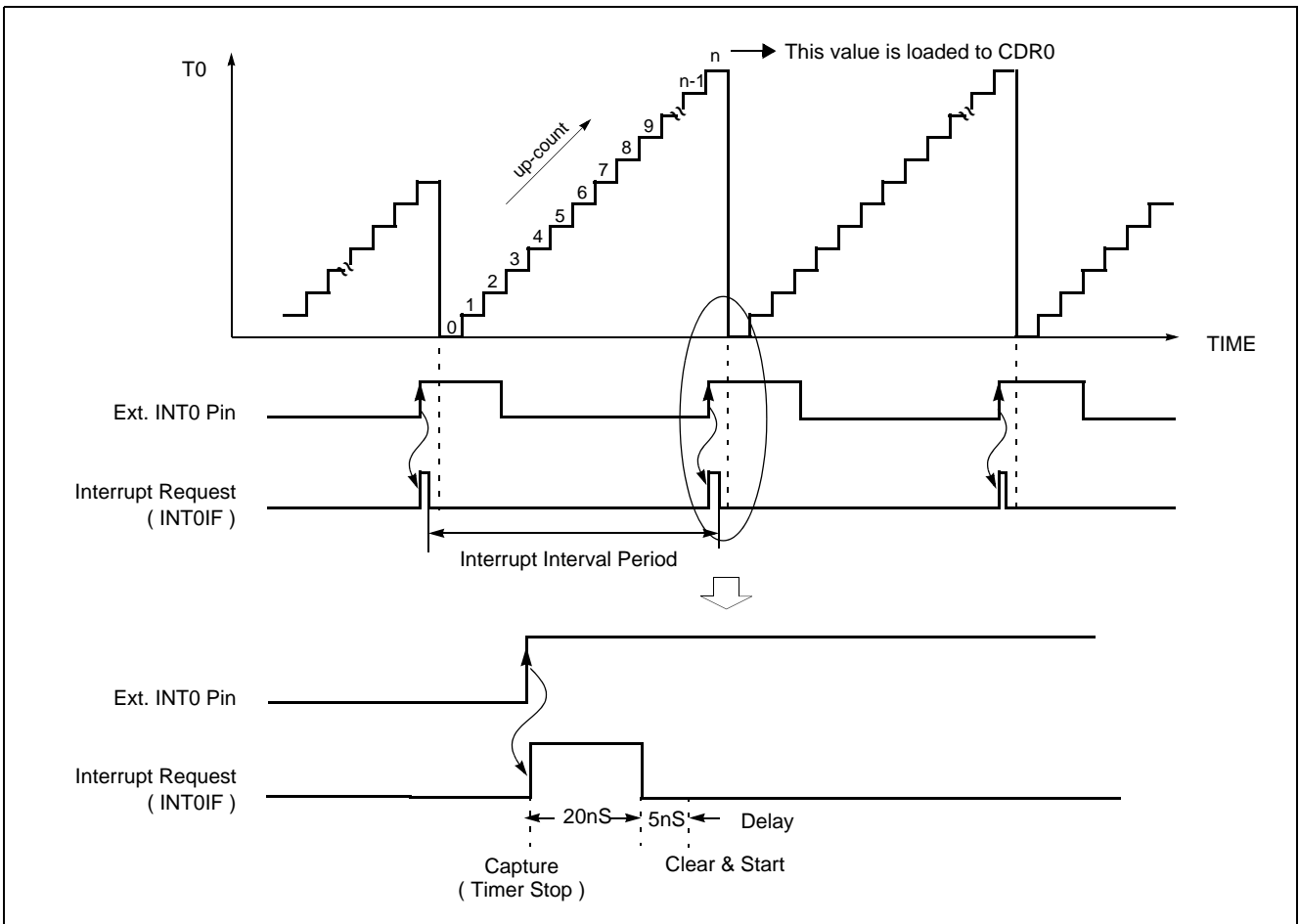

Figure 14-15 Input Capture Operation of Timer 0 Capture mode

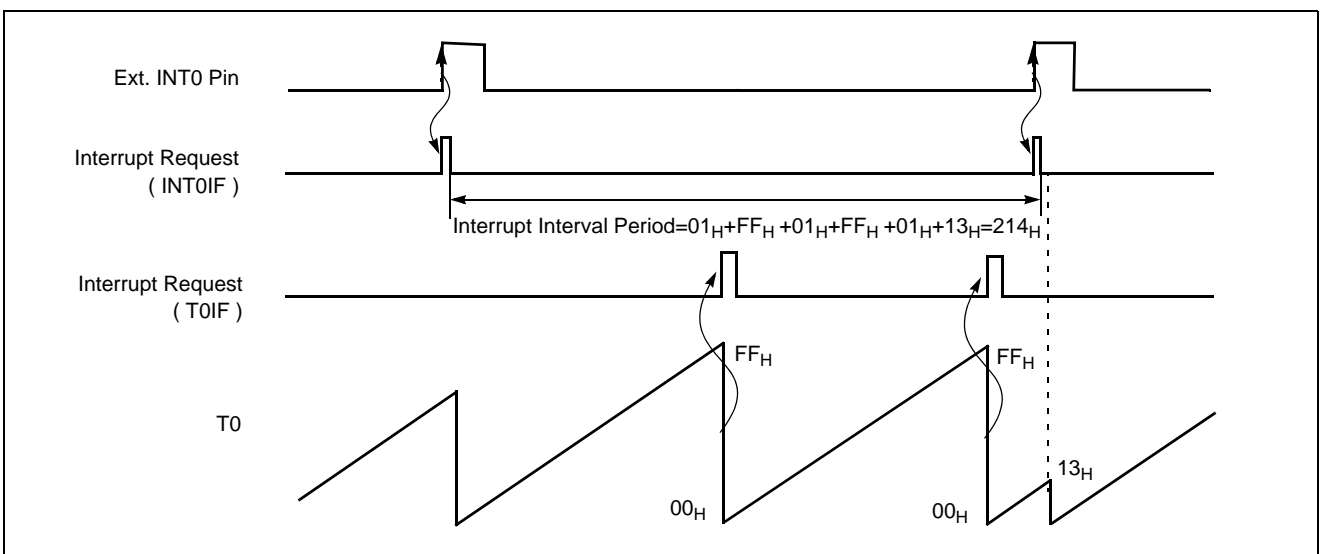

Figure 14-16 Excess Timer Overflow in Capture Mode

14.5 16-bit Capture Mode

16-bit capture mode is the same as 8-bit capture, except that the Timer register is being run will 16 bits. The clock source of the Timer 0 is selected either internal or external clock by bit T0CK[2:0]. In 16-bit mode, the bits T1CK1, T1CK0, CAP1 and 16BIT of TM1 should be set to "1" respectively as shown in Figure 14-17.

ternal clock by bit T2CK[2:0]. In 16-bit mode, the bits T3CK1, T3CK0, CAP3 and 16BIT of TM3 should be set to "1" respectively as shown in Figure 14-18.

The clock source of the Timer 4 is selected either internal or external clock by bit T4CK[2:0] as shown in Figure 14-18.

The clock source of the Timer 2 is selected either internal or ex-

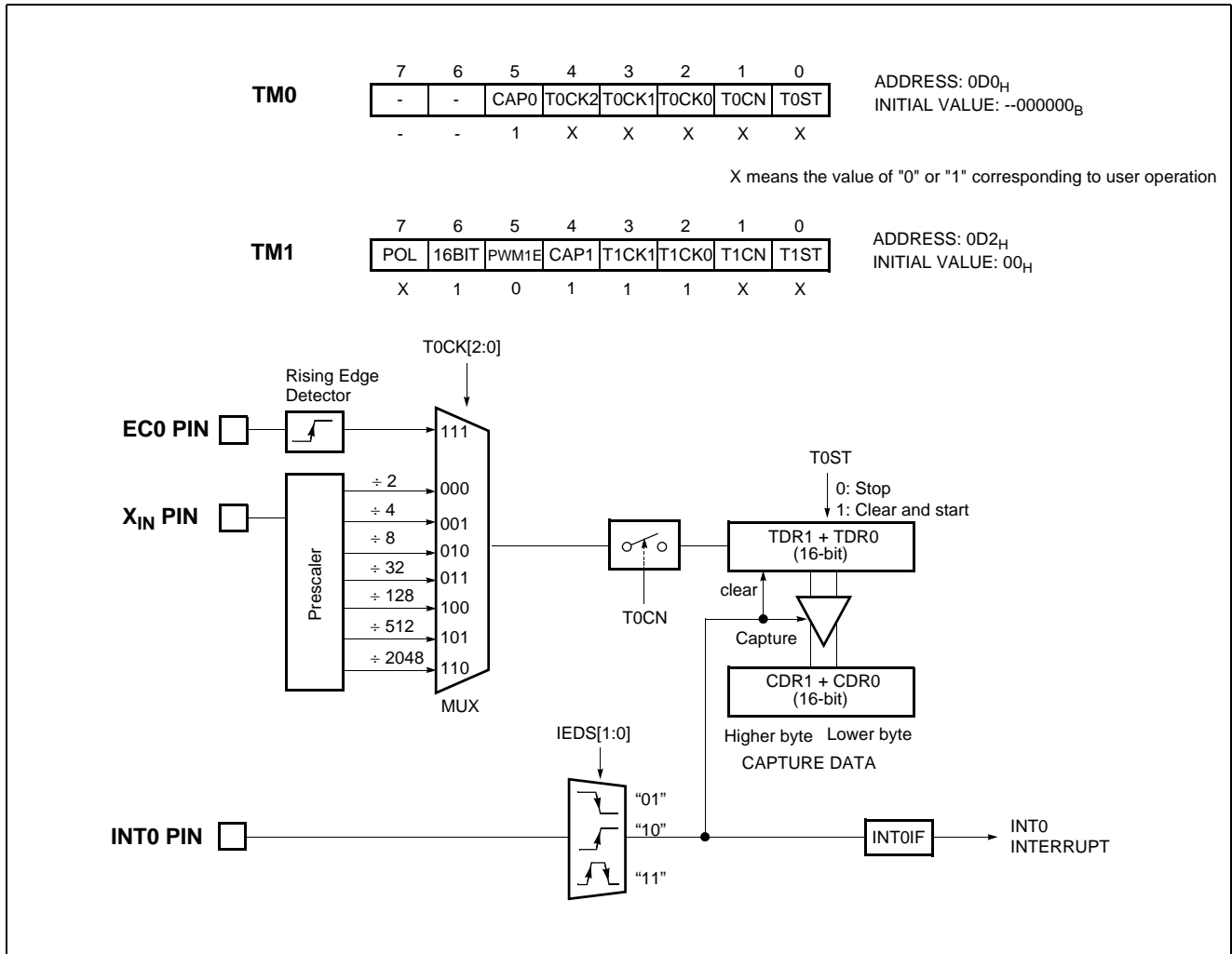

Figure 14-17 16-bit Capture Mode of Timer 0, 1

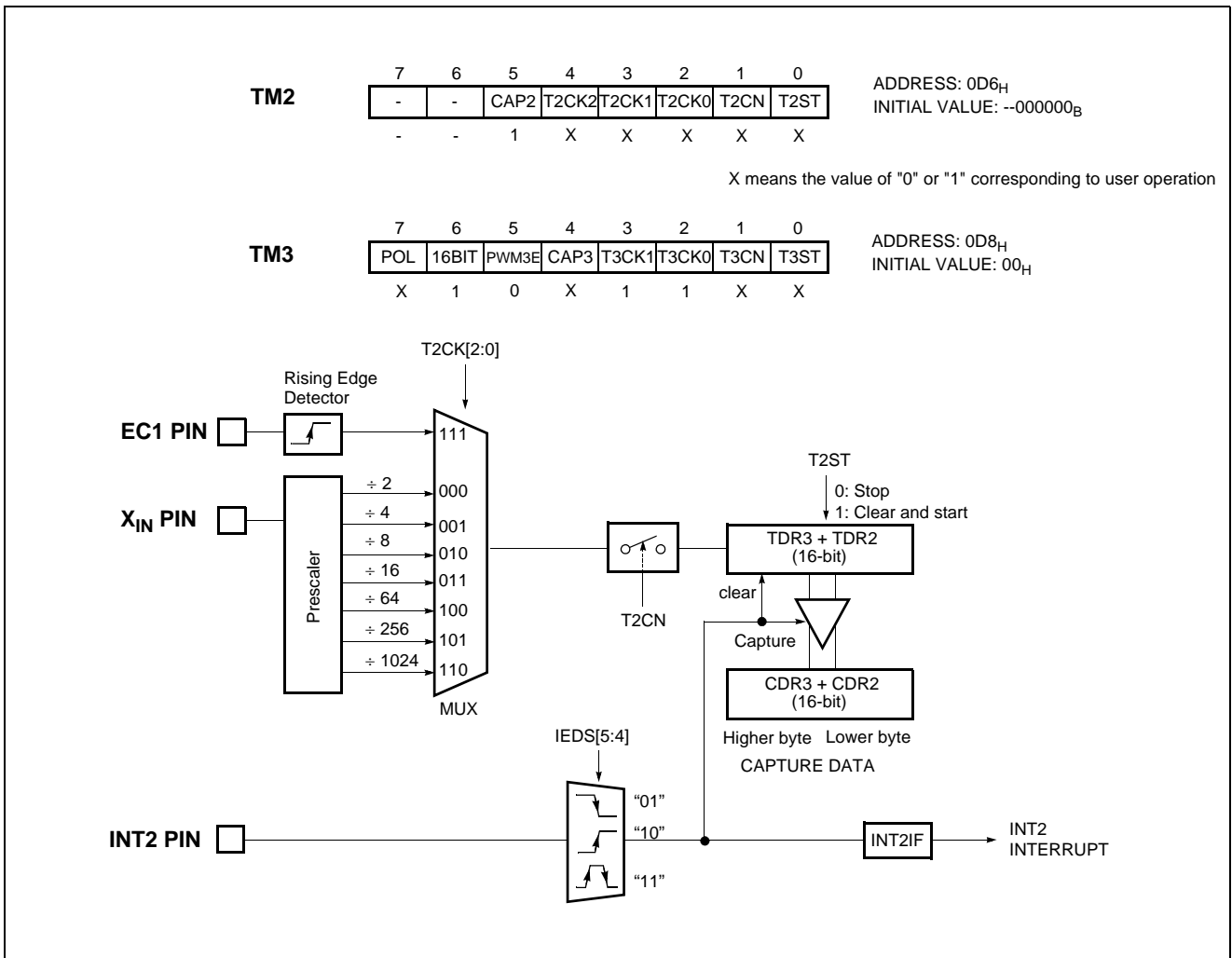

Figure 14-18 16-bit Capture Mode of Timer 2, 3

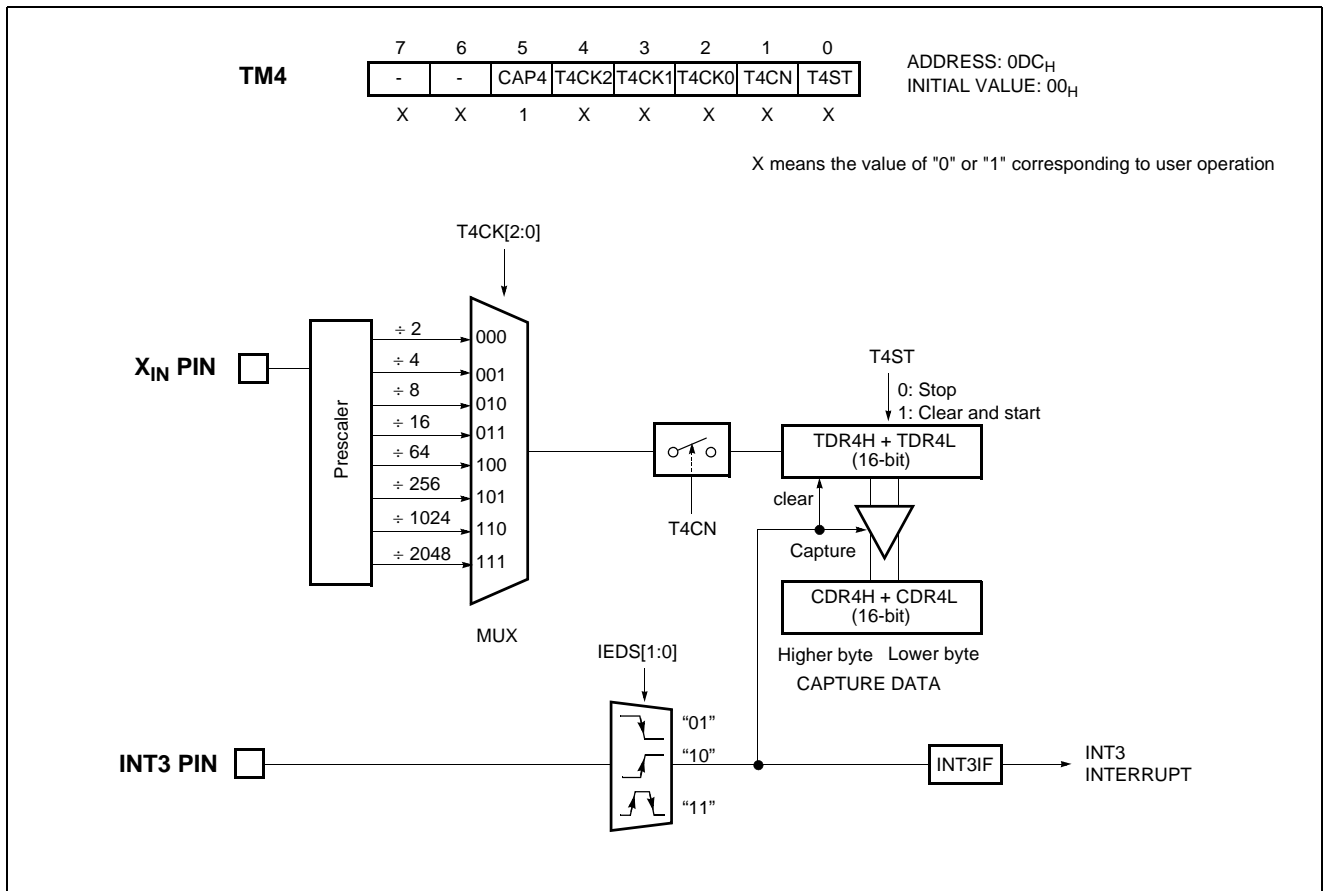

Figure 14-19 16-bit Capture Mode of Timer 4

Example 1:

Timer0 = 16-bit timer mode, 0.5s at 4MHz

```
LDM    TM0,#0000_1111B;8uS
LDM    TM1,#0100_1100B;16bit Mode
LDM    TDR0,#<62499    ;8uS X 62500
LDM    TDR1,#>62499    ;=0.5s
SET1   T0E
EI
:
:
```

Example 2:

Timer0 = 16-bit event counter mode

```
LDM    PSR0,#0001_0000B;EC0 Set
LDM    TM0,#0001_1111B;CounterMode
LDM    TM1,#0100_1100B;16bit Mode
LDM    TDR0,#<0FFFFH    ;
LDM    TDR1,#>0FFFFH    ;
SET1   T0E
```

```
EI
:
:
```

Example 3:

Timer0 = 16-bit capture mode

```
LDM    PSR0,#0000_0001B;INT0 set
LDM    TM0,#0010_1111B;CaptureMode
LDM    TM1,#0100_1100B;16bit Mode
LDM    TDR0,#<0FFFFH    ;
LDM    TDR1,#>0FFFFH    ;
LDM    IEDS,#01H    ;Falling Edge
SET1   T0E
SET1   INT0E
EI
:
:
```

14.6 PWM Mode

The MC80F0424/0432/0448 has a high speed PWM (Pulse Width Modulation) functions which shared with Timer1 and Timer3.

In PWM mode, pin R53/PWM1O and R54/PWM3O outputs up to a 10-bit resolution PWM output. This pin should be configured as a PWM output by setting "1" to bit PWM1O and PWM3O in PSR0 register.

The period of the PWM1 output is determined by the T1PPR (T1 PWM Period Register) and T1PWHR[3:2] (bit3,2 of T1 PWM High Register) and the duty of the PWM1 output is determined by the T1PDR (T1 PWM Duty Register) and T1PWHR[1:0] (bit1,0 of T1 PWM High Register).

The user writes the lower 8-bit period value to the T1PPR and the higher 2-bit period value to the T1PWHR[3:2]. And writes duty value to the T1PDR and the T1PWHR[1:0] same way.

The T1PDR is configured as a double buffering for glitch less PWM output. In Figure 14-1, the duty data is transferred from the master to the slave when the period data matched to the counted value. (i.e. at the beginning of next duty cycle)

PWM1 Period = [PWM1HR[3:2]T1PPR] X Source Clock

PWM1 Duty = [PWM1HR[1:0]T1PDR] X Source Clock

Likewise, the period of the PWM3 output is determined by the T3PPR (T3 PWM Period Register) and T3PWHR[3:2] (bit3,2 of T3 PWM High Register) and the duty of the PWM output is determined by the T3PDR (T3 PWM Duty Register) and T3PWHR[1:0] (bit1,0 of T3 PWM High Register).

The user writes the lower 8-bit period value to the T3PPR and the higher 2-bit period value to the T3PWHR[3:2]. And writes duty value to the T3PDR and the T3PWHR[1:0] same way.

The T3PDR is configured as a double buffering for glitch less PWM output. In Figure 14-21, the duty data is transferred from the master to the slave when the period data matched to the counted value. (i.e. at the beginning of next duty cycle)

PWM3 Period = [PWM3HR[3:2]T3PPR] X Source Clock

PWM3 Duty = [PWM3HR[1:0]T3PDR] X Source Clock

The relation of frequency and resolution is in inverse proportion.

Table 14-4 shows the relation of PWM frequency vs. resolution.

If it needed more higher frequency of PWM, it should be reduced resolution.

Resolution	Frequency		
	T1CK[1:0] = 00(250nS)	T1CK[1:0] = 01(500nS)	T1CK[1:0] = 10(2uS)
10-bit	3.9kHz	0.98kHz	0.49kHz
9-bit	7.8kHz	1.95kHz	0.97kHz
8-bit	15.6kHz	3.90kHz	1.95kHz
7-bit	31.2kHz	7.81kHz	3.90kHz

Table 14-4 PWM Frequency vs. Resolution at 4MHz

The bit POL of TM1 decides the polarity of duty cycle.

If the duty value is set same to the period value, the PWM output is determined by the bit POL (1: High, 0: Low). And if the duty value is set to "00_H", the PWM output is determined by the bit POL (1: Low, 0: High).

It can be changed duty value when the PWM output. However the changed duty value is output after the current period is over. And it can be maintained the duty value at present output when changed only period value shown as Figure 14-23. As it were, the absolute duty time is not changed in varying frequency. But the changed period value must greater than the duty value.

Note: If changing the Timer1 to PWM function, it should be stopped with the timer clock uncounted firstly, and then set period and duty register value. If user writes register values while timer is in operation, these register could be set with certain values.

Ex) Sample Program @4MHz 2uS

```
LDM TM1,#1010_1000b ; Set Clock & PWM1E
LDM T1PPR,#199      ; Period :400uS=2uSX(199+1)
LDM T1PDR,#99       ; Duty:200uS=2uSX(99+1)
LDM PWM1HR,00H
LDM TM1,#1010_1011b ; Start timer1
```

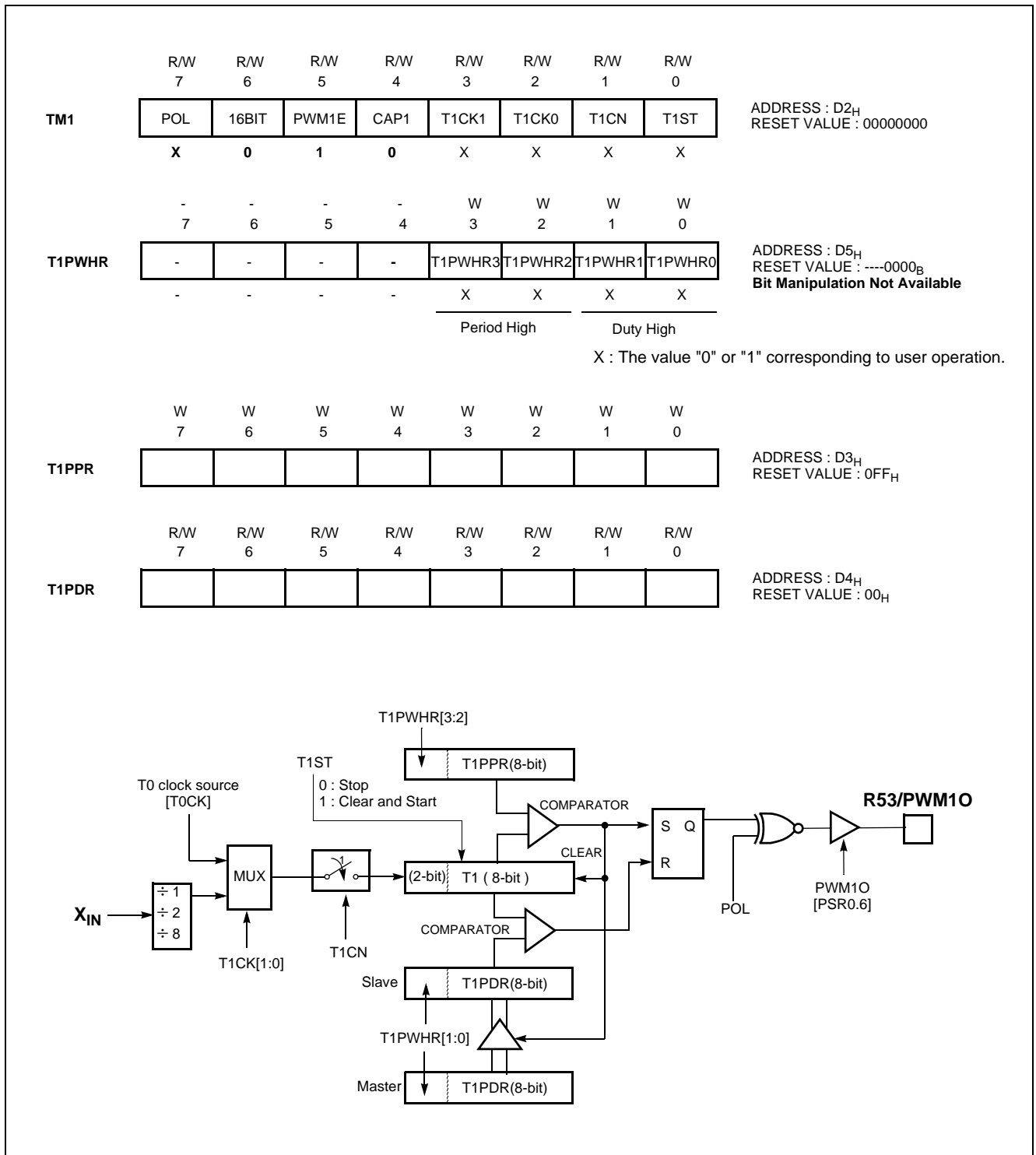

Figure 14-20 PWM1 Mode

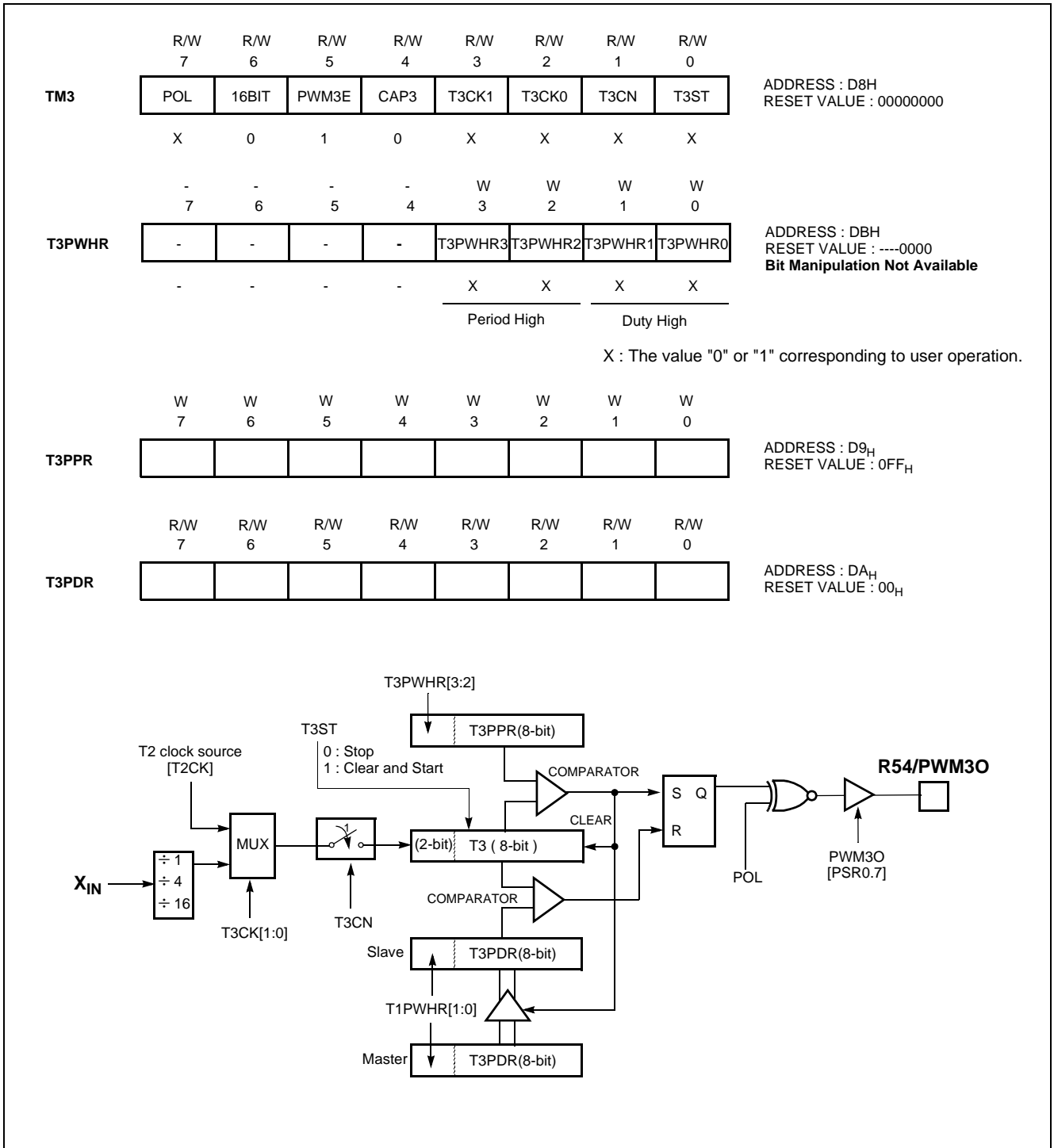

Figure 14-21 PWM3 Mode

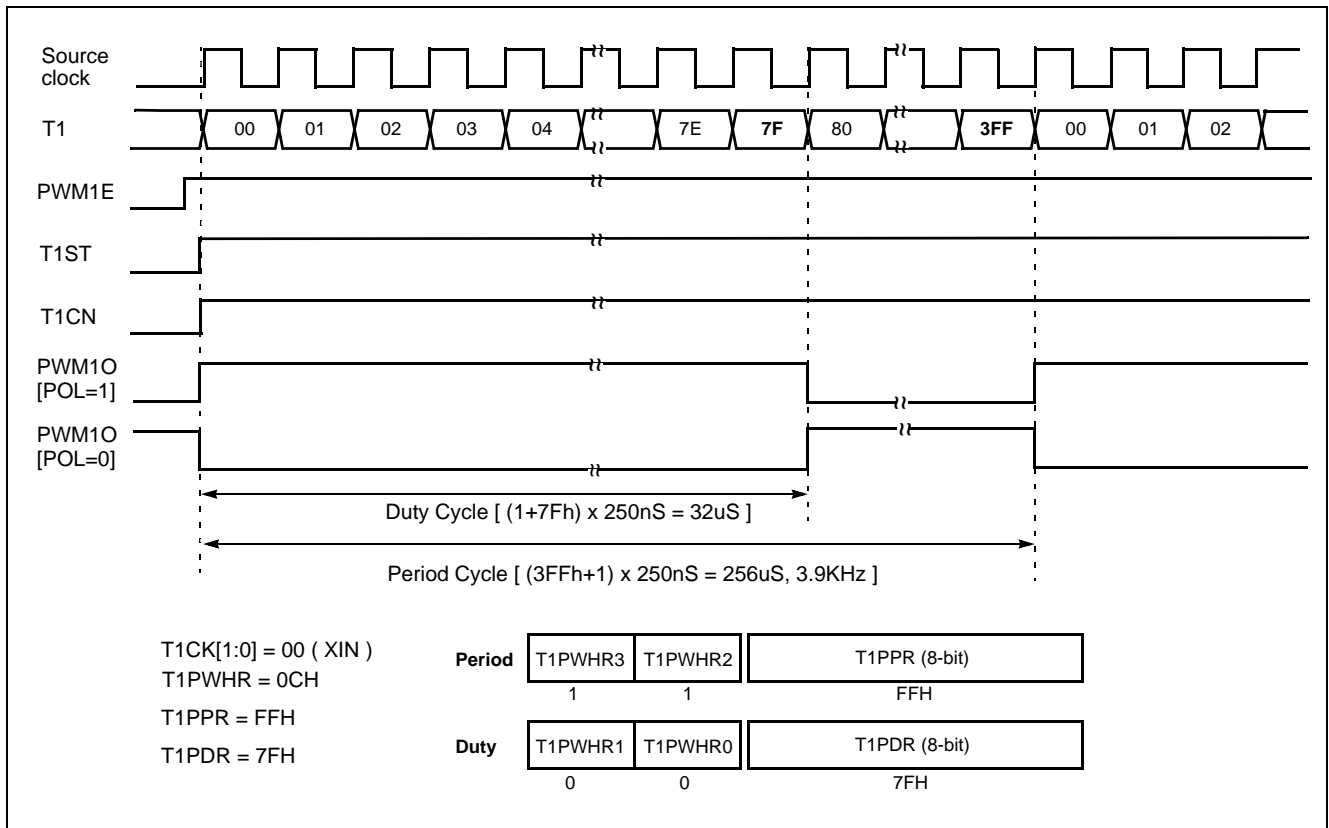

Figure 14-22 Example of PWM at 4MHz

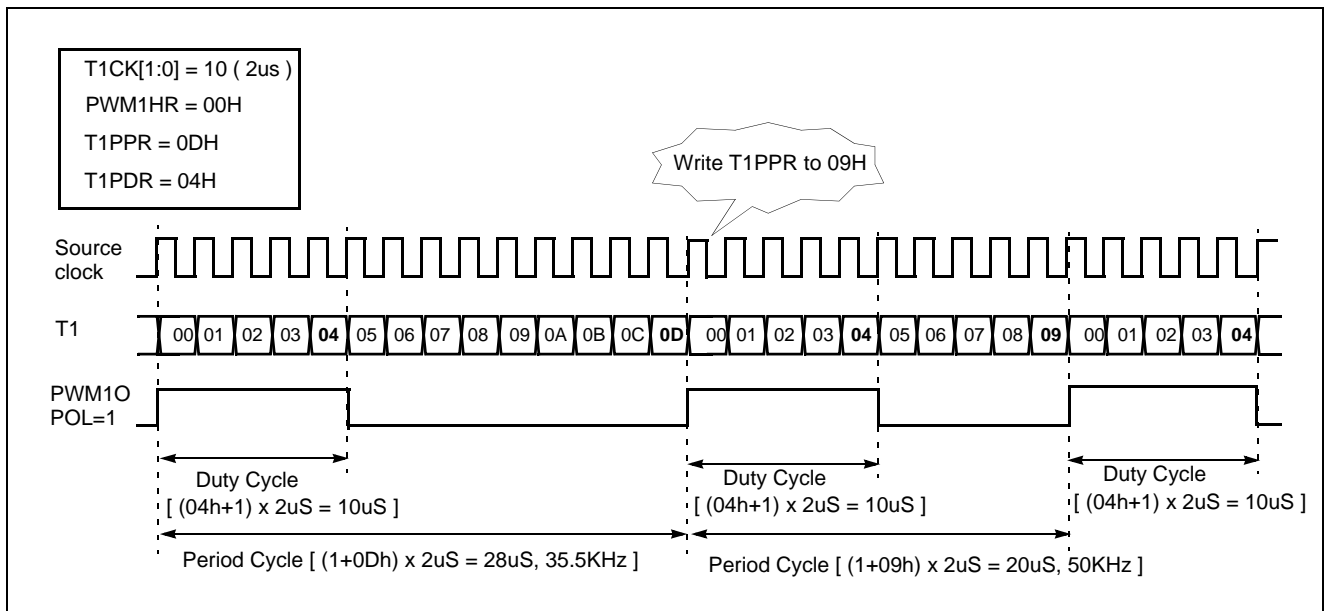

Figure 14-23 Example of Changing the Period in Absolute Duty Cycle (@4MHz)

15. ANALOG TO DIGITAL CONVERTER

The analog-to-digital converter (A/D) allows conversion of an analog input signal to a corresponding 10-bit digital value. The A/D module has sixteen analog inputs, which are multiplexed into one sample and hold. The output of the sample and hold is the input into the converter, which generates the result via successive approximation. The analog supply voltage is connected to AV_{DD} of Sample & Hold logic of A/D module. The AV_{DD} was separated with V_{DD} in order to minimize the degradation of operation characteristic by power supply noise.

The A/D module has three registers which are the control register ADCM and A/D result register ADCRH and ADCRL. The ADCRH[7:6] is used as ADC clock source selection bits too. The register ADCM, shown in Figure 15-4, controls the operation of the A/D converter module. The port pins can be configured as analog inputs or digital I/O.

It is selected for the corresponding channel to be converted by setting ADS[3:0]. The A/D port is set to analog input port by ADEN and ADS[3:0] regardless of port I/O direction register. The port deselected by ADS[3:0] operates as normal port.

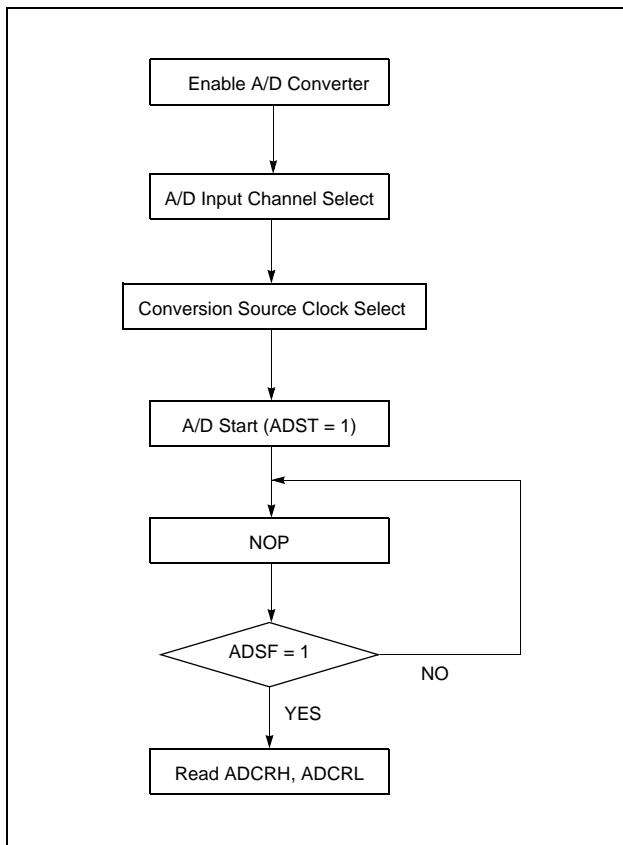

Figure 15-1 A/D Converter Operation Flow

How to Use A/D Converter

The processing of conversion is start when the start bit ADST is set to "1". After one cycle, it is cleared by hardware. The register

ADCRH and ADCRL contains the results of the A/D conversion. When the conversion is completed, the result is loaded into the ADCRH and ADCRL, the A/D conversion status bit ADSF is set to "1", and the A/D interrupt flag ADCIF is set. See Figure 15-1 for operation flow.

The block diagram of the A/D module is shown in Figure 15-3. The A/D status bit ADSF is set automatically when A/D conversion is completed, cleared when A/D conversion is in process. The conversion time takes 12 times of conversion source clock. The period of actual A/D conversion clock should be minimally $1\mu s$

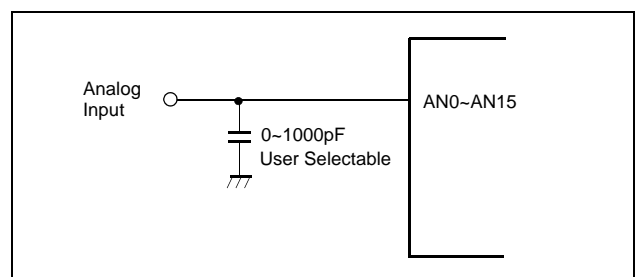

Figure 15-2 Analog Input Pin Connecting Capacitor

A/D Converter Cautions

(1) Input range of AN0 to AN15

The input voltage of AN0 to AN15 should be within the specification range. In particular, if a voltage above AV_{DD} or below AV_{SS} is input (even if within the absolute maximum rating range), the conversion value for that channel can not be indeterminate. The conversion values of the other channels may also be affected.

(2) Noise countermeasures

In order to maintain 10-bit resolution, attention must be paid to noise on pins AV_{DD} and AN0 to AN15. Since the effect increases in proportion to the output impedance of the analog input source, it is recommended in some cases that a capacitor be connected externally as shown in Figure 15-2 in order to reduce noise. The capacitance is user-selectable and appropriately determined according to the target system.

(3) Pins AN0/R60 to AN15/R77

The analog input pins AN0 to AN15 also function as input/output port (PORT R6 and R7) pins. When A/D conversion is performed with any of pins AN0 to AN15 selected, be sure not to execute a PORT input instruction while conversion is in progress, as this may reduce the conversion resolution.

Also, if digital pulses are applied to a pin adjacent to the pin in the process of A/D conversion, the expected A/D conversion value may not be obtainable due to coupling noise. Therefore, avoid applying pulses to pins adjacent to the pin undergoing A/D conversion.

(4) AV_{DD} pin input impedance

A series resistor string of approximately $5K\Omega$ is connected between the AV_{DD} pin and the AV_{SS} pin. Therefore, if the output impedance of the analog power source is high, this will result in

parallel connection to the series resistor string between the AV_{DD} pin and the AV_{SS} pin, and there will be a large analog supply voltage error.

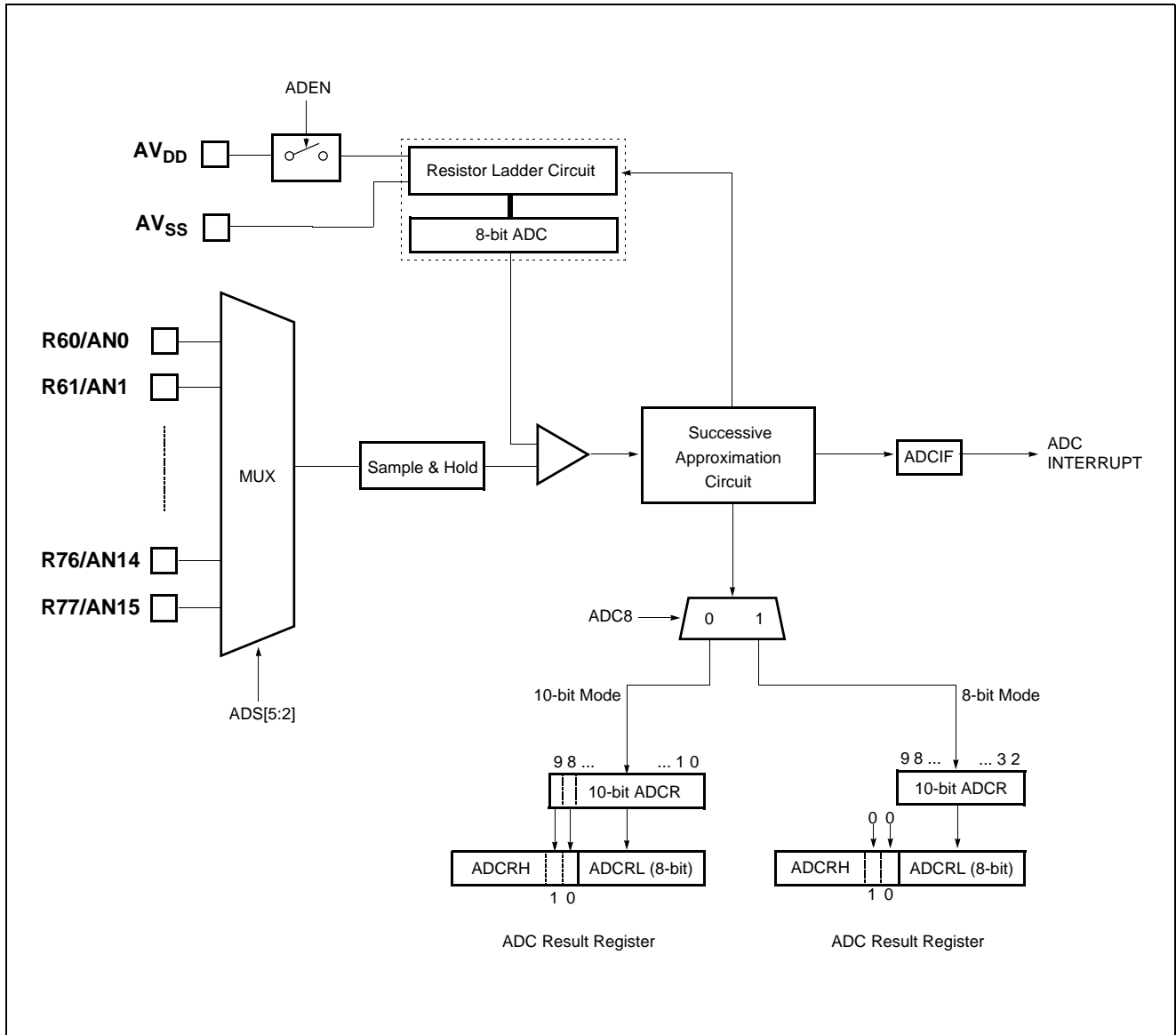

Figure 15-3 A/D Block Diagram

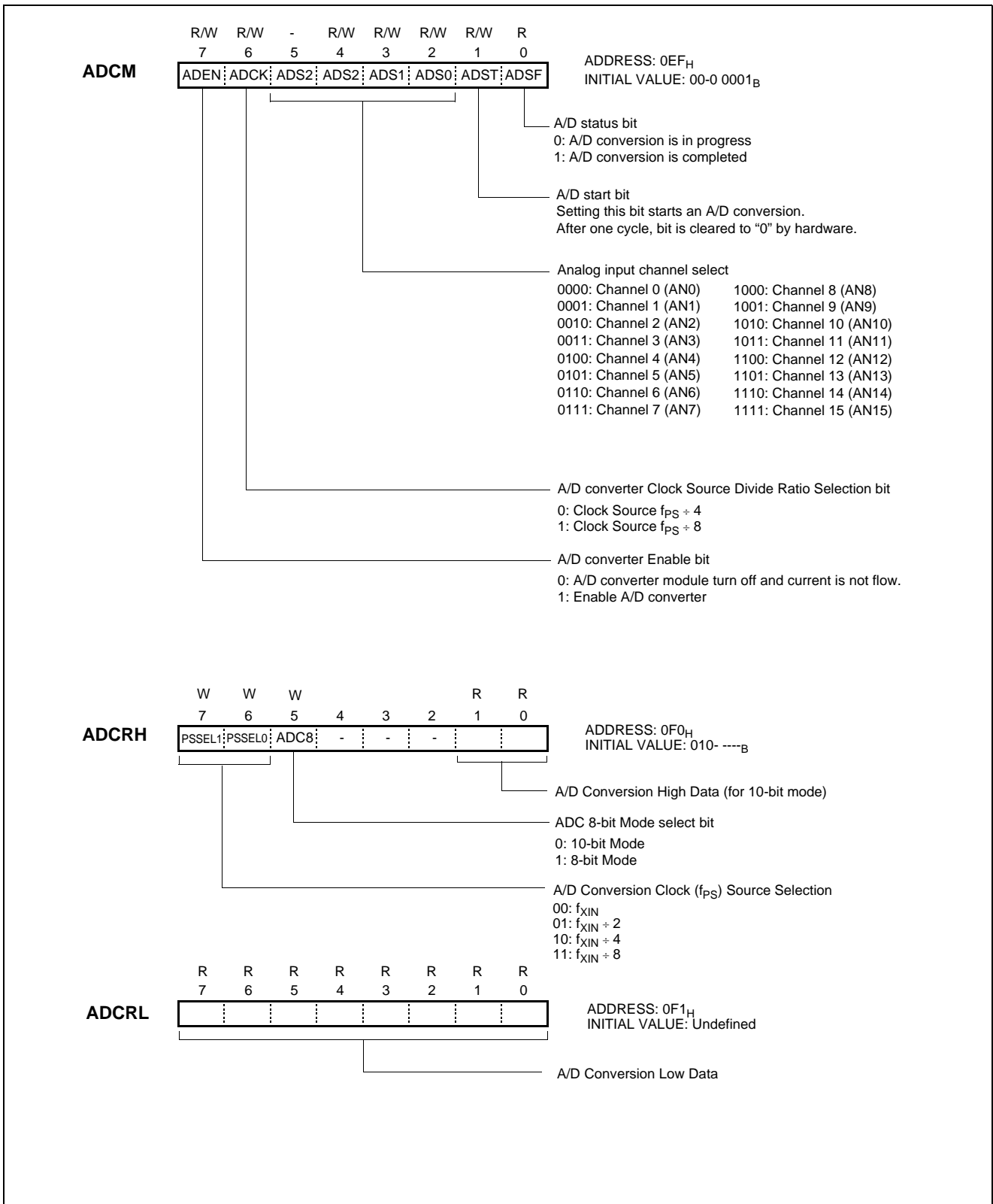

Figure 15-4 A/D Converter Control & Result Register

16. SERIAL INPUT/OUTPUT (SIO)

The serial Input/Output is used to transmit/receive 8-bit data serially. The Serial Input/Output(SIO) module is a serial interface useful for communicating with other peripheral of microcontroller devices. These peripheral devices may be serial EEPROMs, shift registers, display drivers, A/D converters, etc. This SIO is 8-bit clock synchronous type and consists of serial I/O data register, serial I/O mode register, clock selection circuit, octal counter and

control circuit as illustrated in Figure 16-1. The SO pin is designed to input and output. So the Serial I/O(SIO) can be operated with minimum two pin. Pin R42/SCK, R43/SI, and R44/SO pins are controlled by the Serial Mode Register. The contents of the Serial I/O data register can be written into or read out by software. The data in the Serial Data Register can be shifted synchronously with the transfer clock signal.

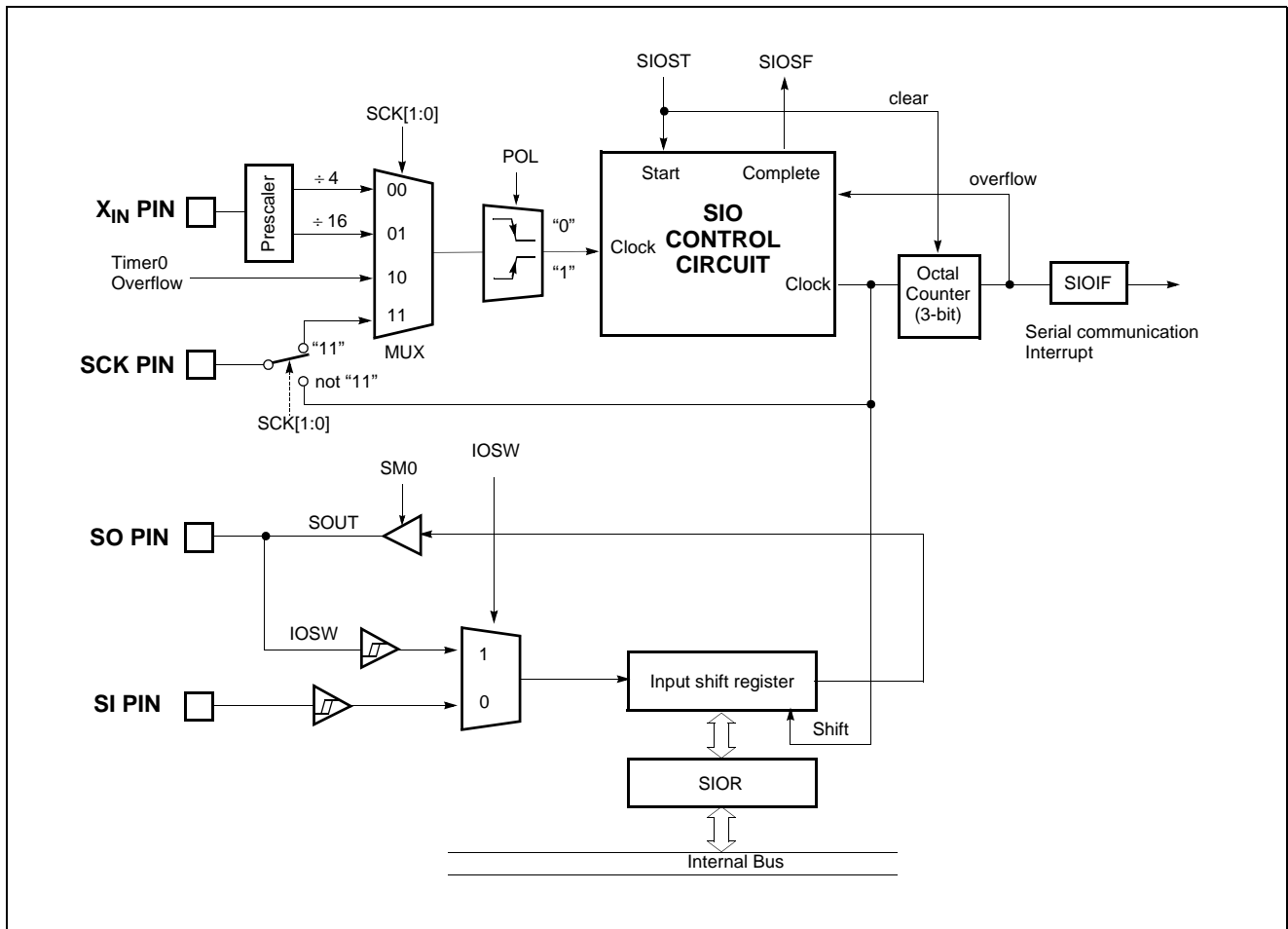

Figure 16-1 SIO Block Diagram

Serial I/O Mode Register(SIOM) controls serial I/O function. According to SCK1 and SCK0, the internal clock or external clock can be selected.

Serial I/O Data Register(SIOR) is an 8-bit shift register. First LSB is send or is received.

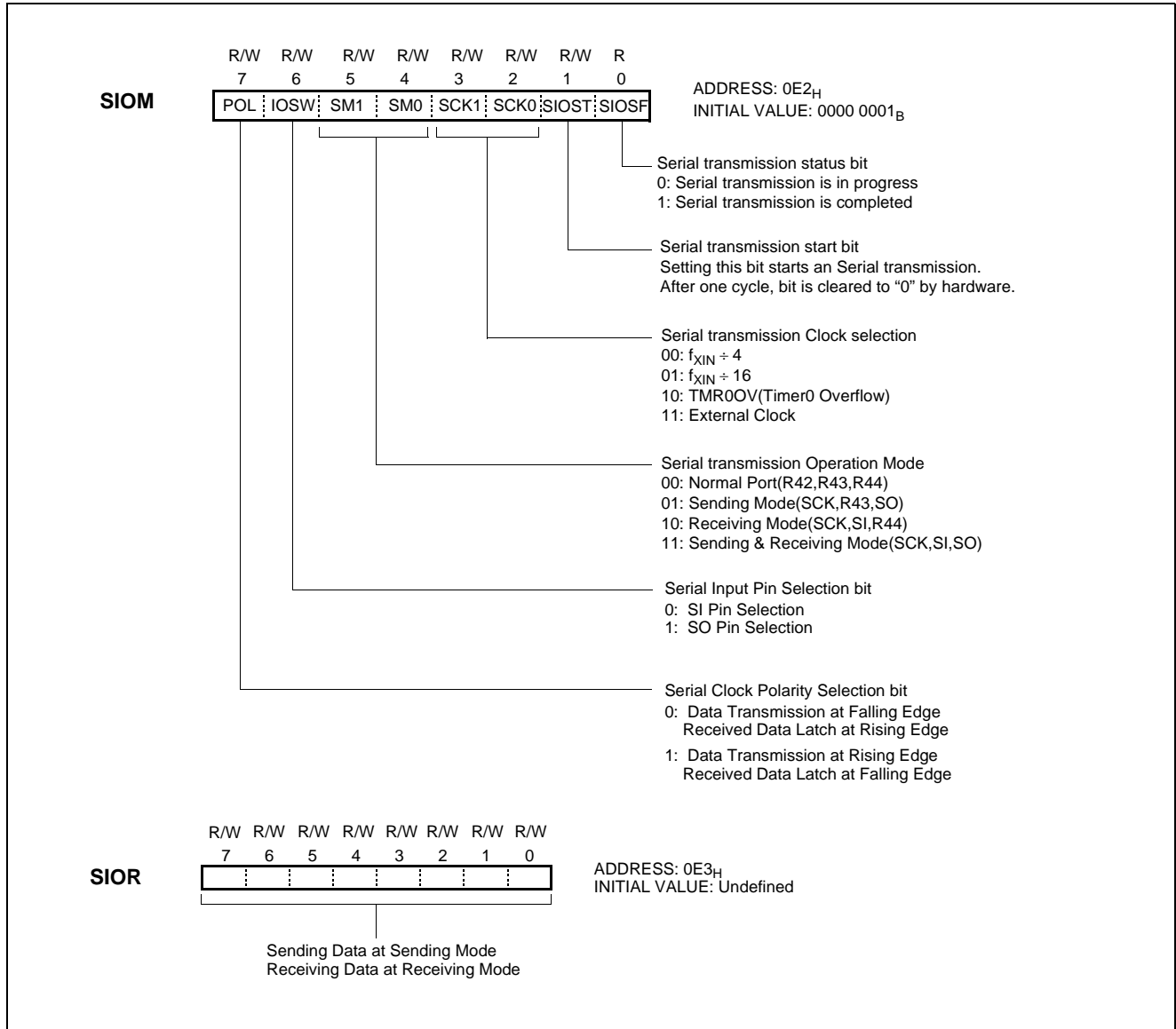

Figure 16-2 SIO Control Register

16.1 Transmission/Receiving Timing

The serial transmission is started by setting SIOST(bit1 of SIOM) to "1". After one cycle of SCK, SIOST is cleared automatically to "0". At the default state of POL bit clear, the serial output data from 8-bit shift register is output at falling edge of SCLK, and in-

put data is latched at rising edge of SCLK pin (Refer to Figure 16-3). When transmission clock is counted 8 times, serial I/O counter is cleared as '0'. Transmission clock is halted in "H" state and serial I/O interrupt(SIOIF) occurred.

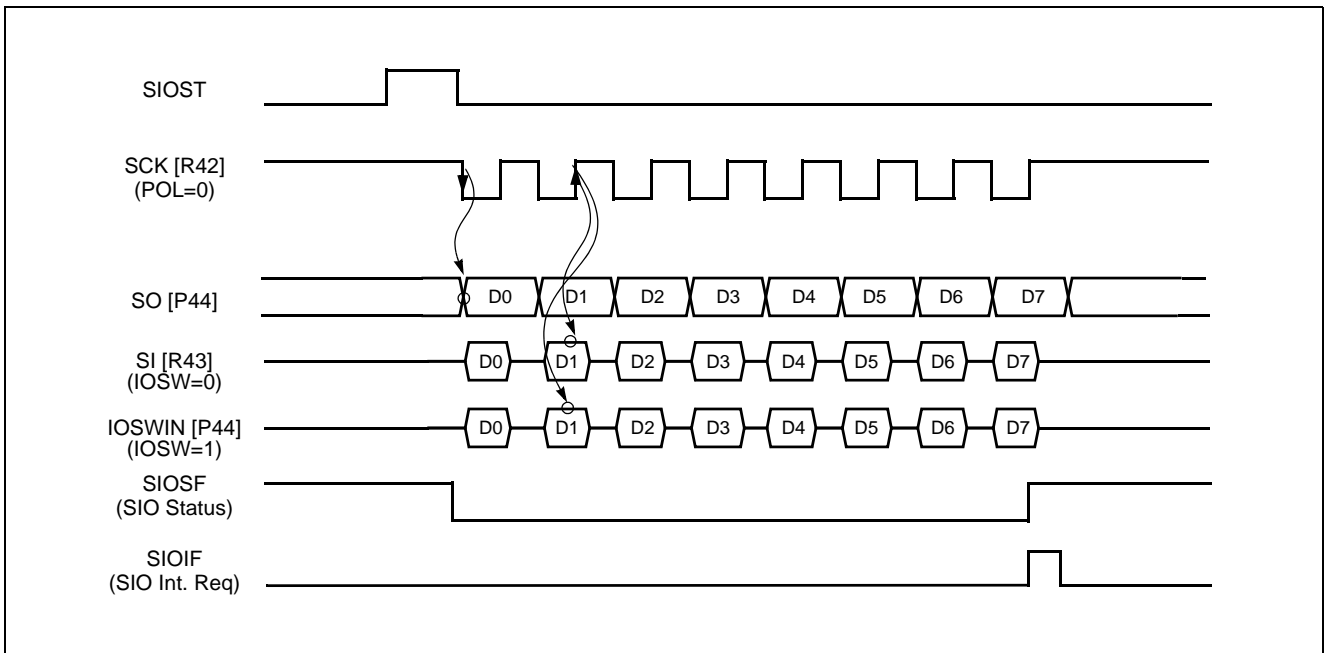

Figure 16-3 Serial I/O Timing Diagram at POL=0

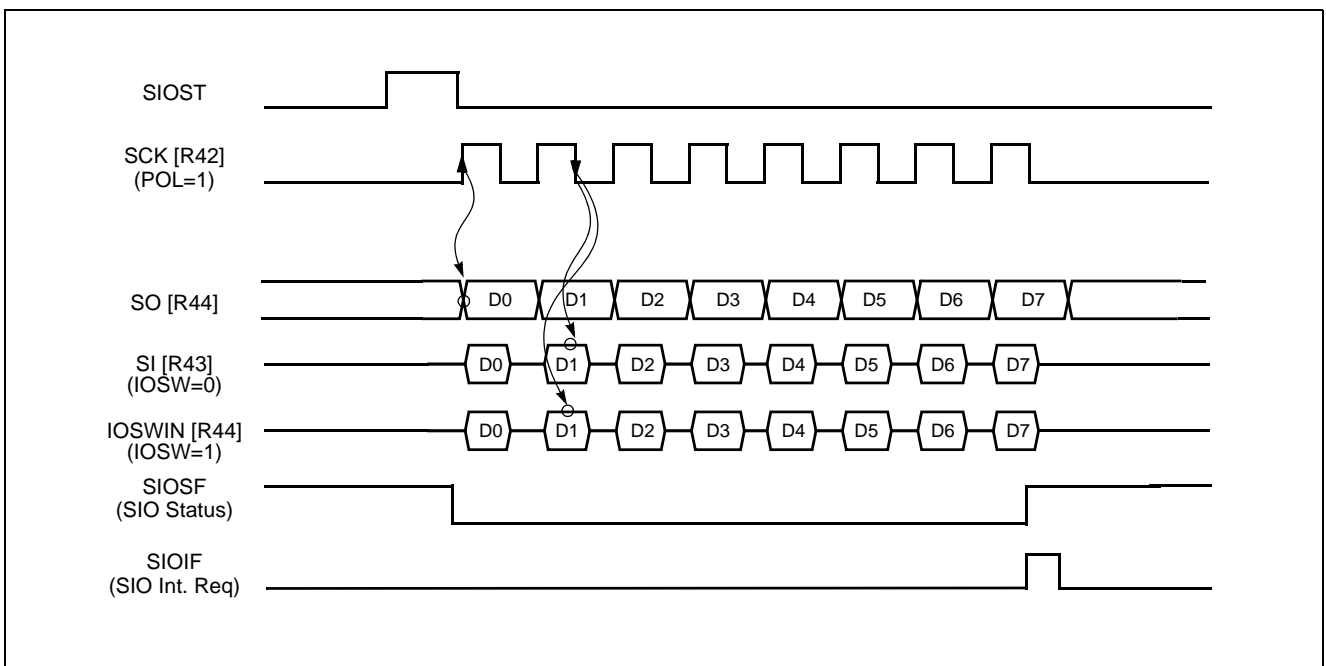

Figure 16-4 Serial I/O Timing Diagram at POL=1

16.2 The method of Serial I/O

1. Select transmission/receiving mode.
2. In case of sending mode, write data to be send to SIOR.
3. Set SIOST to "1" to start serial transmission.
4. The SIO interrupt is generated at the completion of SIO and SIOIF is set to "1". In SIO interrupt service routine, correct transmission should be tested.
5. In case of receiving mode, the received data is acquired by reading the SIOR.

```

LDM    SIOR,#0AAh    ;set tx data
LDM    SIOM,#0011_1100b ;set SIO mode
NOP
LDM    SIOM,#0011_1110b ;SIO Start
    
```

Note: When external clock is used, the frequency should be less than 1MHz and recommended duty is 50%. If both transmission mode is selected and transmission is performed simultaneously, error will be made.

16.3 The Method to Test Correct Transmission

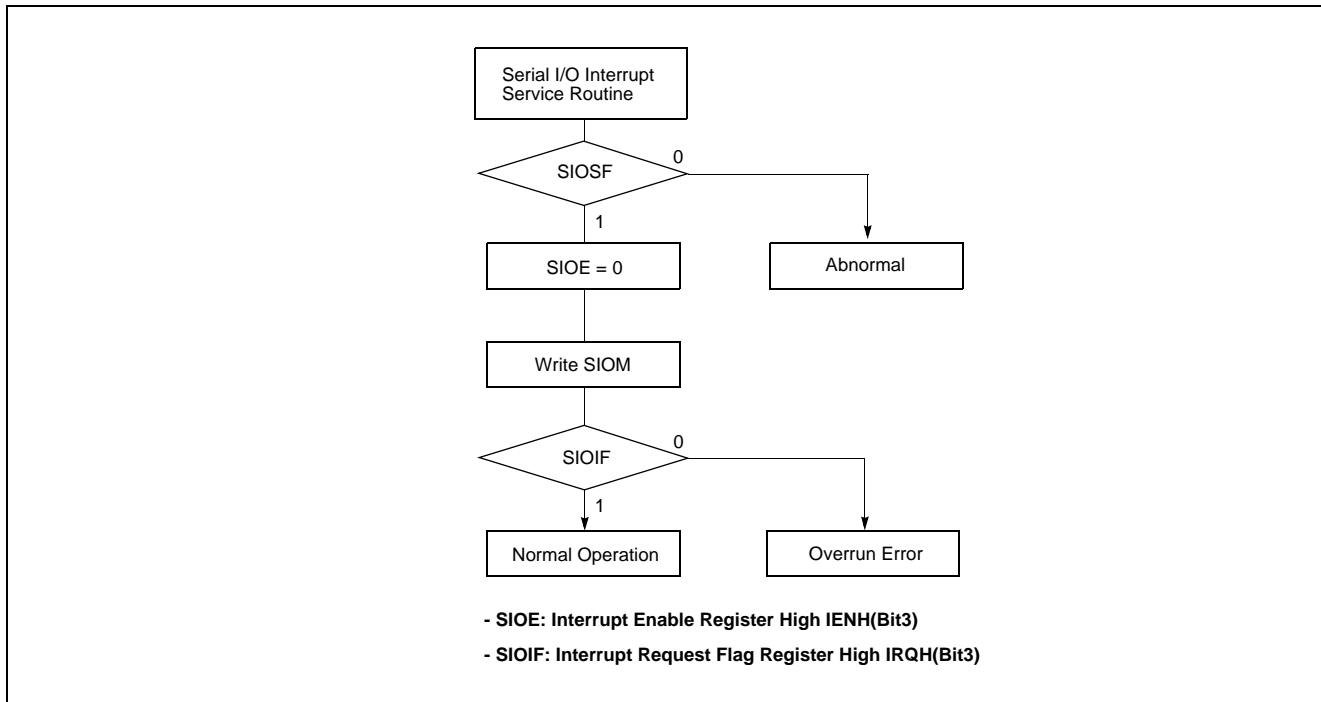

Figure 16-5 Serial IO Method to Test Transmission

17. UNIVERSAL ASYNCHRONOUS RECEIVER/TRANSMITTER (UART)

17.1 UART Serial Interface Functions

The Universal Asynchronous Receiver/Transmitter(UART) enables full-duplex operation wherein one byte of data after the start bit is transmitted and received. The on-chip baud rate generator dedicated to UART enables communications using a wide range of selectable baud rates. In addition, a baud rate can also be defined by dividing clocks input to the ACLK pin.

The UART driver consists of RXR, TXR, ASIMR, ASISR and BRGCR register. Clock asynchronous serial I/O mode (UART) can be selected by ASIMR register. Figure 17-1 shows a block diagram of the UART driver.

In operation of UART0 and UART1, their operations are same as UART0 and UART1

Note: The UART1 control register ASIMR1, ASISR1, BRGCR1, RXR1 and TXR1 are located at EE6H ~ EE9H address. These address must be controlled (read and written) by absolute addressing manipulation instruction.

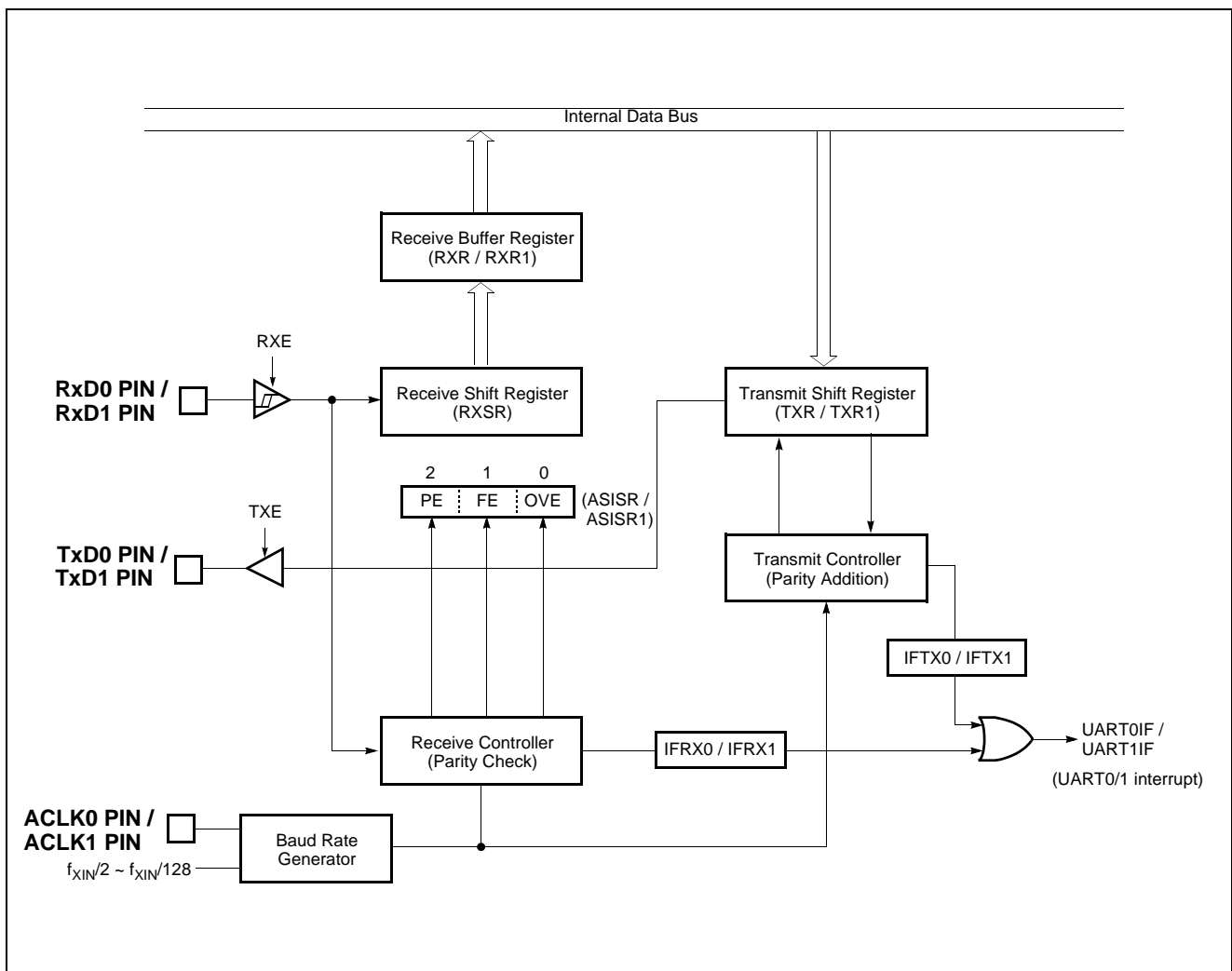

Figure 17-1 UART Block Diagram

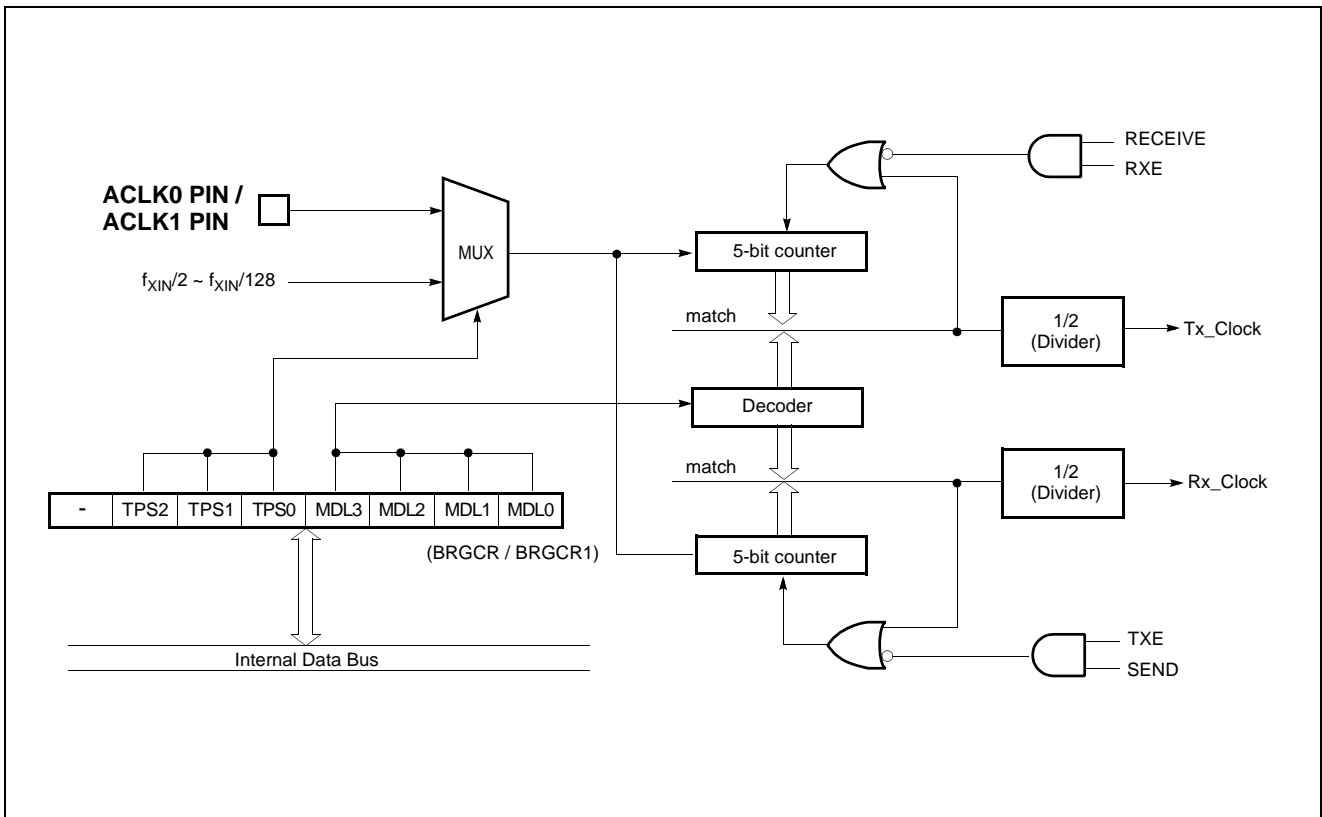

Figure 17-2 Baud Rate Generator Block Diagram

17.2 Serial Interface Configuration

The UART interface consists of the following hardware.

Item	Configuration
Register	Transmit shift register (TXR) Receive buffer register (RXR) Receive shift register
Control register	Serial interface mode register (ASIMR) Serial interface status register (ASISR) Baudrate generator control register (BRGCR)

Table 17-1 Serial Interface Configuration

Transmit shift register (TXR)

This is the register for setting transmit data. Data written to TXR is transmitted as serial data. When the data length is set as 7 bit, bit 0 to 6 of the data written to TX are transferred as transmit data. Writing data to TXR starts the transmit operation. TXR can be written by an 8 bit memory manipulation instruction. It cannot be read. The RESET input sets TXR to 0FFH.

Note: Do not write to TXR during a transmit operation. The

same address is assigned to TXR and the receive buffer register (RXR). A read operation reads values from RXR.

Receive buffer register (RXR)

This register is used to hold receive data. When one byte of data is received, one byte of new receive data is transferred from the receive shift register (RXSR). When the data length is set as 7 bits, receive data is sent to bits 0 to 6 of RXR. In this case, the MSB of RXR always becomes 0.

RXR can be read by an 8 bit memory manipulation instruction. It cannot be written. The RESET input sets RXR to 00H.

Note: The same address is assigned to RXR and the transmit shift register (TXR). During a write operation, values are written to TXR.

Receive shift register

This register converts serial data input via the RxD pin to parallel data. When one byte of data is received at this register cannot be manipulated directly by a program.

Asynchronous serial interface mode register (ASIMR)

This is an 8 bit register that controls UART serial transfer operation. ASIMR is set by a 1 bit or 8 bit memory manipulation instruction. The **RESET** input sets ASIMR to 0000_00-B. Table 17-2 shows the format of ASIMR.

Address : 0E6H / EE6H
Reset value : 0000-00-B

ASIMR / ASIMR1	TXE	RXE	PS1	PS0	-	SL	ISRM	
----------------	-----	-----	-----	-----	---	----	------	--

TXE	RXE	Operation Mode	RxD Pin Func.	TxD Pin Func.
0	0	Operation stop	Port function(R46)	Port function(R47)
0	1	UART mode (Receive only)	Serial function (RxD0)	
1	0	UART mode (Transmit only)	Port function (R46)	Serial function (TxD0)
1	1	UART mode (RX & TX)	Serial function (RxD0)	

PS1	PS0	Parity Bit Specification
0	0	No parity
0	1	Zero parity always added during transmission. No parity detection during reception (parity errors do not occur)
1	0	Odd parity
1	1	Even parity

SL	Stop Bit Length for Specification for Transmit Data
0	1 bit
1	2 bit

ISRM	Receive interrupt request is issued when an error occurs
0	Receive Completion Interrupt Control When Error Occurs
1	Receive completion interrupt request is not issued when an error occurs

Table 17-2 Asynchronous Serial Interface Mode register (ASIMR) format

Note: Do not switch the operation mode until the current serial transmit/receive operation has stopped.

Asynchronous serial interface status register (ASISR)

When a receive error occurs during UART mode, this register indicates the type of error. ASISR can be read by an 8 bit memory manipulation instruction. The **RESET** input sets ASISR to ----000B. Table 17-3 shows the format of ASISR.

Address : 0E7H / EE7H
Reset value : ----000B

ASISR / ASISR1	-	-	-	-	-	PE	FE	OVE
----------------	---	---	---	---	---	----	----	-----

PE	Parity Error Flag
0	No parity error
1	Parity error (Transmit data parity not matched)

FE	Frame Error Flag
0	No Frame error
1	Framing error ^{Note1} (stop bit not detected)

OVE	Overrun Error Flag
0	No overrun error
1	Overrun error ^{Note2} (Next receive operation was completed before data was read from receive buffer register (RXR))

Note 1. Even if a stop bit length is set to 2 bits by setting bit2(SL) in ASIMR, stop bit detection during a receive operation only applies to a stop bit length of 1bit.

2. Be sure to read the contents of the receive buffer register(RXR) when an overrun error has occurred. Until the contents of RXR are read, further overrun errors will occur when receiving data.

Table 17-3 Asynchronous Serial Interface Status Register (ASISR) Format

Baud rate generator control register (BRGCR)

This register sets the serial clock for serial interface. BRGCR is set by an 8 bit memory manipulation instruction. The **RESET** input sets BRGCR to -001_0000B.

Table 17-4 shows the format of BRGCR.

Address : 0E8H / EE8H
Reset value : -0010000B

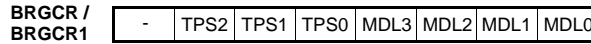

TPS2	TPS1	TPS0	Source Clock Selection for 5 Bit count	n
0	0	0	ACLK0 / ACLK1	0
0	0	1	$f_{XIN} / 2$	1
0	1	0	$f_{XIN} / 4$	2
0	1	1	$f_{XIN} / 8$	3
1	0	0	$f_{XIN} / 16$	4
1	0	1	$f_{XIN} / 32$	5
1	1	0	$f_{XIN} / 64$	6
1	1	1	$f_{XIN} / 128$	7

MDL3	MDL2	MDL1	MDL0	Input Clock Selection	k
0	0	0	0	$f_{SCK} / 16$	0
0	0	0	1	$f_{SCK} / 17$	1
0	0	1	0	$f_{SCK} / 18$	2
0	0	1	1	$f_{SCK} / 19$	3
0	1	0	0	$f_{SCK} / 20$	4
0	1	0	1	$f_{SCK} / 21$	5
0	1	1	0	$f_{SCK} / 22$	6
0	1	1	1	$f_{SCK} / 23$	7
1	0	0	0	$f_{SCK} / 24$	8
1	0	0	1	$f_{SCK} / 25$	9
1	0	1	0	$f_{SCK} / 26$	10
1	0	1	1	$f_{SCK} / 27$	11
1	1	0	0	$f_{SCK} / 28$	12
1	1	0	1	$f_{SCK} / 29$	13
1	1	1	0	$f_{SCK} / 30$	14
1	1	1	1	Setting prohibited	-

Caution Writing to BRGCR/BRGXR1 during a communication operation may cause abnormal output from the baud rate generator and disable further communication operations. Therefore, do not write to BRGCR/BRGCR1 during a communication operation.

Remarks 1. f_{SCK} : Source clock for 5 bit counter
2. n : Value set via TPS0 to TPS2 ($0 \leq n \leq 7$)
3. k : Source clock for 5 bit counter ($0 \leq k \leq 14$)

Table 17-4 Baud Rate Generator Control Register (BRGCR / BRGCR1) Format

17.3 Communication operation

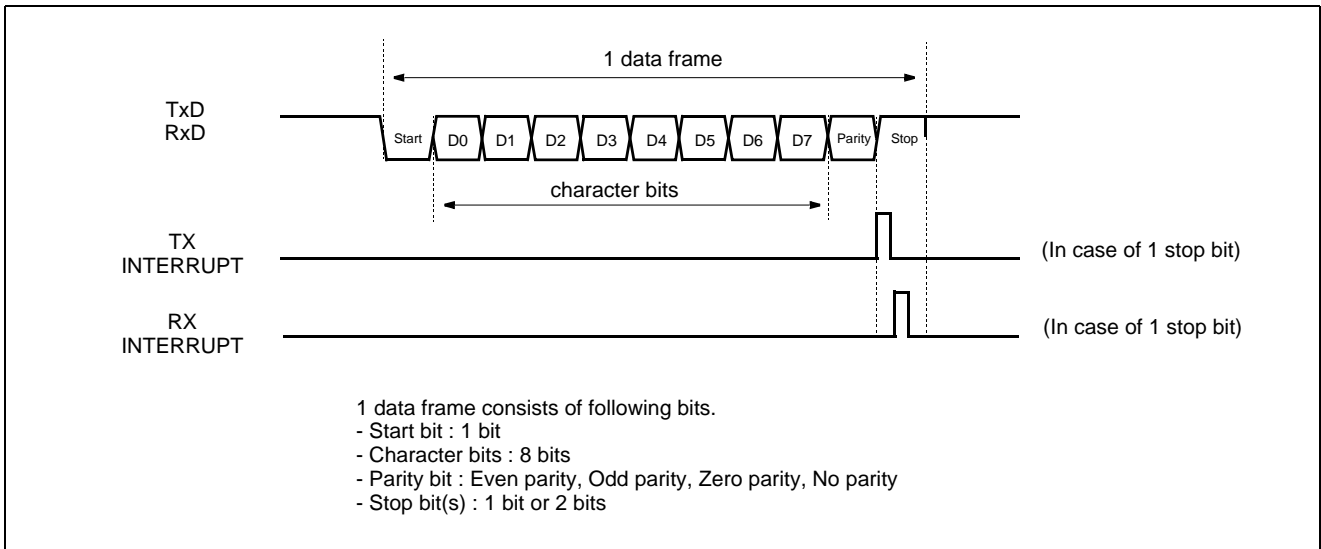

Figure 17-3 UART data format and interrupt timing diagram

The transmit operation is enabled when bit 7 (TXE) of the asynchronous serial interface mode register (ASIMR/ASIMR1) is set to 1. The transmit operation is started when transmit data is written to the transmit shift register (TXR). The timing of the transmit completion interrupt request is shown in Figure 17-3. The receive operation is enabled when bit 6 (RXE) of the asyn-

chronous serial interface mode register (ASIMR/ASIMR1) is set to 1, and input via the RxD0 pin is sampled. The serial clock specified by ASIMR/ASIMR1 is used to sample the RxD0/RxD1 pin. Once reception of one data frame is completed, a receive completion interrupt request (UART0IF/UART1IF) occurs. Even if an error has occurred, the receive data in which the error occurred is

still transferred to RXR. When bit 1 (ISRM) of ASIMR(ASIMR1) is cleared to 0 upon occurrence of an error, interrupt by Rx occurs. When ISRM bit is set to 1, interrupt by Rx does not occur in case of error occurrence. Figure 17-3 shows the timing of the asynchronous serial interface receive completion interrupt request.

17.4 Relationship between main clock and baud rate

The transmit/receive clock that is used to generate the baud rate is obtained by dividing the main system clock or ACLK0/ACLK1 pin clock. The baud rate generated from the main system clock or ACLK0/ACLK1 pin clock is determined according to the following formula. If the high 4 bits of BRGCR/BRGCR1 is 0, ACLK0/ACLK1 pin clock is used for source clock of baud rate generator.

$$\text{Baud Rate} = f_{XIN} / (2^{n+1}(k+16))$$

- f_{XIN} : Main system clock oscillation frequency

When ACLK0/ACLK1 is selected as the source clock of the 5-bit counter, substitute the input clock frequency to ACLK0/ACLK1 pin clock for in the above expression.

- n : Value set via TPS0 to TPS2 ($0 \leq n \leq 7$)

- k : Value set via MDL0 to MDL3 ($0 \leq k \leq 14$)

Baud Rate (bps)	$f_{XIN}=12M$		$f_{XIN}=11.0592M$		$f_{XIN}=10.0M$		$f_{XIN}=8.0M$		$f_{XIN}=6.0M$		$f_{XIN}=5.0M$		$f_{XIN}=4.0M$	
	BRGCR	ERR (%)	BRGCR	ERR (%)	BRGCR	ERR (%)	BRGCR	ERR (%)	BRGCR	ERR (%)	BRGCR	ERR (%)	BRGCR	ERR (%)
600	-	-	-	-	-	-	-	-	-	-	-	-	7AH	0.16
1200	-	-	-	-	-	-	7AH	0.16	74H	2.34	70H	1.73	6AH	0.16
2400	74H	2.34	72H	0.00	70H	1.73	6AH	0.16	64H	2.34	60H	1.73	5AH	0.16
4800	64H	2.34	62H	0.00	60H	1.73	5AH	0.16	54H	2.34	50H	1.73	4AH	0.16
9600	54H	2.34	52H	0.00	50H	1.73	4AH	0.16	44H	2.34	40H	1.73	3AH	0.16
19200	44H	2.34	42H	0.00	40H	1.73	3AH	0.16	34H	2.34	30H	1.73	2AH	0.16
31250	38H	0.00	36H	0.53	34H	0.00	30H	0.00	28H	0.00	24H	0.00	20H	0.00
38400	34H	2.34	32H	0.00	30H	1.73	2AH	0.16	24H	2.34	20H	1.73	1AH	0.16
57600	2AH	0.16	28H	0.00	26H	1.35	21H	2.11	1AH	0.16	16H	1.36	11H	2.12
76800	24H	2.34	22H	0.00	20H	1.73	1AH	0.16	14H	2.34	10H	1.73	-	-
115200	1AH	0.16	18H	0.00	16H	1.36	11H	2.12	-	-	-	-	-	-

Table 17-5 Relationship between main clock and Baud Rate

17.5 Communication operation

The transmit operation is enabled when bit 7 (TXE) of the asynchronous serial interface mode register (ASIMR/ASIMR1) is set to 1. The transmit operation is started when transmit data is written to the transmit shift register (TXR/TXR1). The timing of the transmit completion interrupt request is shown in Figure 17-3.

The receive operation is enabled when bit 6 (RXE) of the asynchronous serial interface mode register (ASIMR/ASIMR1) is set to 1, and input via the RxD0/RxD1 pin is sampled. The serial clock specified by ASIMR/ASIMR1 is used to sample the RxD0/RxD1 pin. Once reception of one data frame is completed, a receive completion interrupt request (UART0IF/UART1IF) occurs. Even if an error has occurred, the receive data in which the error occurred is still transferred to RXR/RXR1. When ASIMR bit 1 (ISRM) is cleared to 0 upon occurrence of an error, UART0/UART1 interrupt occurs. When ISRM bit is set to 1, UART0/UART1 interrupt does not occur in case of error occurrence. Figure 17-3 shows the timing of the asynchronous serial interface receive completion interrupt request.

In case of using interrupts of UART0 Tx and UART0 Rx together, it is necessary to check IFR in interrupt service routine to find out which interrupt is occurred, because the UART0 Tx and UART0 Rx is shared with interrupt vector address.

In case of using interrupts of UART1 Tx and UART1 Rx together, it is necessary to check IFR in interrupt service routine to find out which interrupt is occurred, because the UART1 Tx and UART1 Rx is shared with interrupt vector address.

These flag bits must be cleared by software after reading this register. These flag bits must be cleared by software after reading this register. Each processing step is determined by IFR as shown

in Figure 17-1.

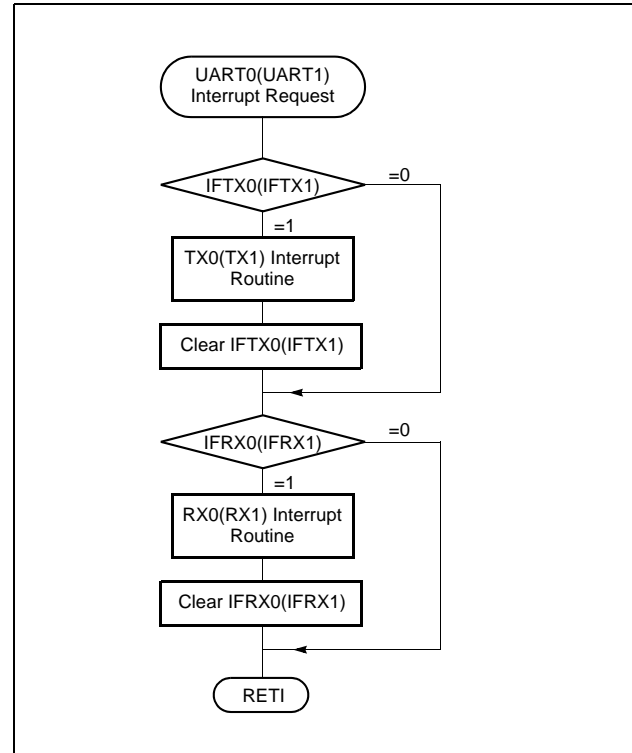

Figure 17-1 Shared Interrupt Vector of UART

18. BUZZER FUNCTION

The buzzer driver block consists of 6-bit binary counter, buzzer register BUZR, and clock source selector. It generates square-wave which has very wide range frequency (488Hz ~ 250kHz at $f_{XIN} = 4\text{MHz}$) by user software.

A 50% duty pulse can be output to R13/BUZO pin to use for piezo-electric buzzer drive. Pin R13 is assigned for output port of Buzzer driver by setting the bit 2 of PSR1(address 0F9H) to "1". For PSR1 register, refer to Figure 10-3.

Example: 5kHz output at 4MHz.

```
LDM BUZR, #0011_0001B
LDM PSR1, #XXXX_X1XXB
```

X means don't care

The bit 0 to 5 of BUZR determines output frequency for buzzer driving.

Equation of frequency calculation is shown below.

$$f_{BUZ} = \frac{f_{XIN}}{2 \times DivideRatio \times (BUR + 1)}$$

- f_{BUZ} : Buzzer frequency
- f_{XIN} : Oscillator frequency
- Divide Ratio: Prescaler divide ratio by BUCK[1:0]
- BUR: Lower 6-bit value of BUZR. Buzzer period value.

The frequency of output signal is controlled by the buzzer control register BUZR. The bit 0 to bit 5 of BUZR determine output frequency for buzzer driving.

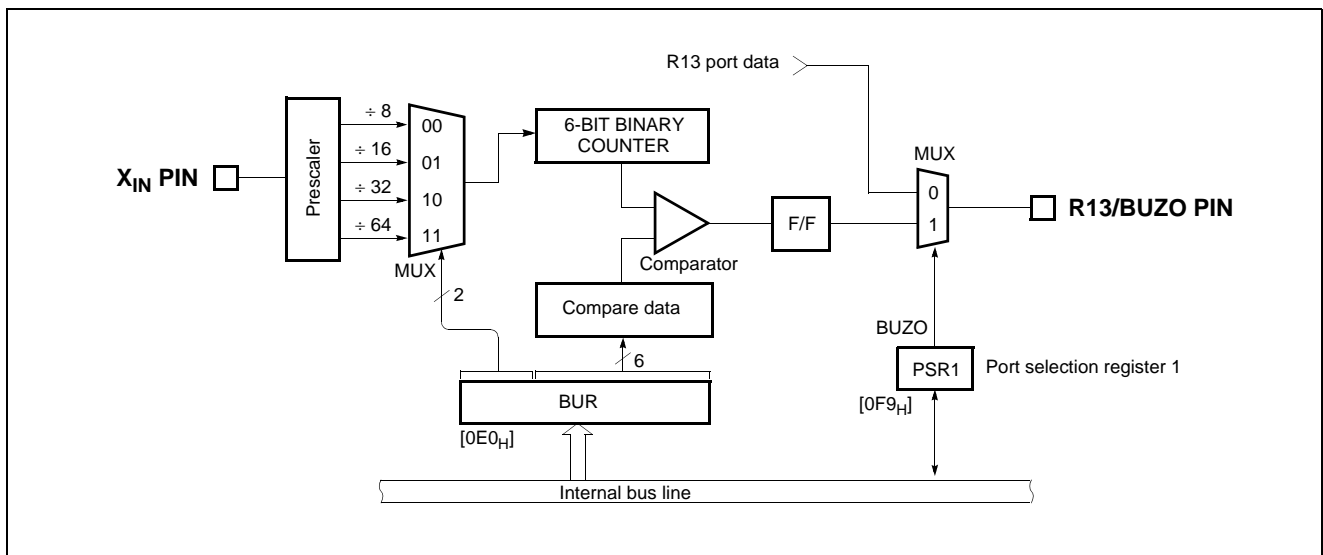

Figure 18-1 Block Diagram of Buzzer Driver

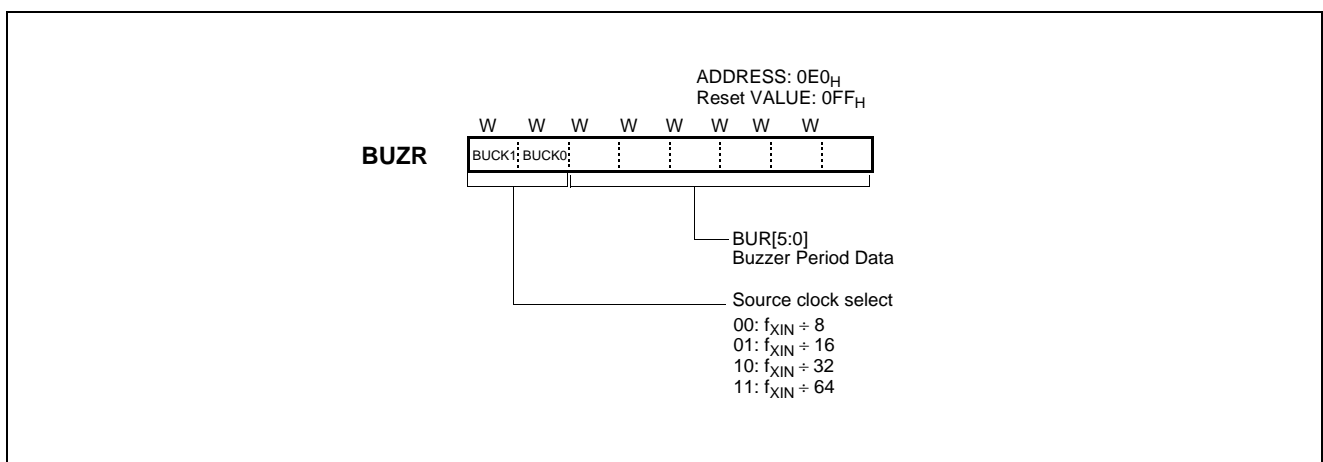

Figure 18-2 Buzzer Register

The 6-bit counter is cleared and starts the counting by writing signal at BUZR register. It is incremental from 00_H until it matches 6-bit BUR value.

When main-frequency is 4MHz, buzzer frequency is shown as below Table 18-1.

BUR [5:0]	BUR[7:6]				BUR [5:0]	BUR[7:6]			
	00	01	10	11		00	01	10	11
00	250.000	125.000	62.500	31.250	20	7.576	3.788	1.894	0.947
01	125.000	62.500	31.250	15.625	21	7.353	3.676	1.838	0.919
02	83.333	41.667	20.833	10.417	22	7.143	3.571	1.786	0.893
03	62.500	31.250	15.625	7.813	23	6.944	3.472	1.736	0.868
04	50.000	25.000	12.500	6.250	24	6.757	3.378	1.689	0.845
05	41.667	20.833	10.417	5.208	25	6.579	3.289	1.645	0.822
06	35.714	17.857	8.929	4.464	26	6.410	3.205	1.603	0.801
07	31.250	15.625	7.813	3.906	27	6.250	3.125	1.563	0.781
08	27.778	13.889	6.944	3.472	28	6.098	3.049	1.524	0.762
09	25.000	12.500	6.250	3.125	29	5.952	2.976	1.488	0.744
0A	22.727	11.364	5.682	2.841	2A	5.814	2.907	1.453	0.727
0B	20.833	10.417	5.208	2.604	2B	5.682	2.841	1.420	0.710
0C	19.231	9.615	4.808	2.404	2C	5.556	2.778	1.389	0.694
0D	17.857	8.929	4.464	2.232	2D	5.435	2.717	1.359	0.679
0E	16.667	8.333	4.167	2.083	2E	5.319	2.660	1.330	0.665
0F	15.625	7.813	3.906	1.953	2F	5.208	2.604	1.302	0.651
10	14.706	7.353	3.676	1.838	30	5.102	2.551	1.276	0.638
11	13.889	6.944	3.472	1.736	31	5.000	2.500	1.250	0.625
12	13.158	6.579	3.289	1.645	32	4.902	2.451	1.225	0.613
13	12.500	6.250	3.125	1.563	33	4.808	2.404	1.202	0.601
14	11.905	5.952	2.976	1.488	34	4.717	2.358	1.179	0.590
15	11.364	5.682	2.841	1.420	35	4.630	2.315	1.157	0.579
16	10.870	5.435	2.717	1.359	36	4.545	2.273	1.136	0.568
17	10.417	5.208	2.604	1.302	37	4.464	2.232	1.116	0.558
18	10.000	5.000	2.500	1.250	38	4.386	2.193	1.096	0.548
19	9.615	4.808	2.404	1.202	39	4.310	2.155	1.078	0.539
1A	9.259	4.630	2.315	1.157	3A	4.237	2.119	1.059	0.530
1B	8.929	4.464	2.232	1.116	3B	4.167	2.083	1.042	0.521
1C	8.621	4.310	2.155	1.078	3C	4.098	2.049	1.025	0.512
1D	8.333	4.167	2.083	1.042	3D	4.032	2.016	1.008	0.504
1E	8.065	4.032	2.016	1.008	3E	3.968	1.984	0.992	0.496
1F	7.813	3.906	1.953	0.977	3F	3.907	1.953	0.977	0.488

Table 18-1 buzzer frequency (kHz unit)

19. INTERRUPTS

The MC80F0424/0432/0448 interrupt circuits consist of Interrupt enable register (IENH, IENL), Interrupt request flags of IRQH, IRQL, Priority circuit, and Master enable flag ("I" flag of PSW). Fifteen interrupt sources are provided. The configuration of interrupt circuit is shown in Figure 19-1 and interrupt priority is shown in Table 19-1.

The External Interrupts INT0 ~ INT3 each can be transition-activated (1-to-0 or 0-to-1 transition) by selection IEDS register. The flags that actually generate these interrupts are bit INTOIF, INT1IF, INT2IF and INT3IF in register IRQH. When an external interrupt is generated, the generated flag is cleared by the hardware when the service routine is vectored to only if the interrupt was transition-activated.

The Timer 0 ~ Timer 4 Interrupts are generated by T0IF, T1IF,

T2IF, T3IF and T4IF which is set by a match in their respective timer/counter register.

The Basic Interval Timer Interrupt is generated by BITIF which is set by an overflow in the timer register.

The AD converter Interrupt is generated by ADCIF which is set by finishing the analog to digital conversion.

The Watchdog timer and Watch Timer Interrupt is generated by WDTIF and WTIF which is set by a match in Watchdog timer register or Watch timer register. The IFR (Interrupt Flag Register) is used for discrimination of the interrupt source among these two Watchdog timer and Watch Timer Interrupt.

The Basic Interval Timer Interrupt is generated by BITIF which is set by a overflow in the timer counter register.

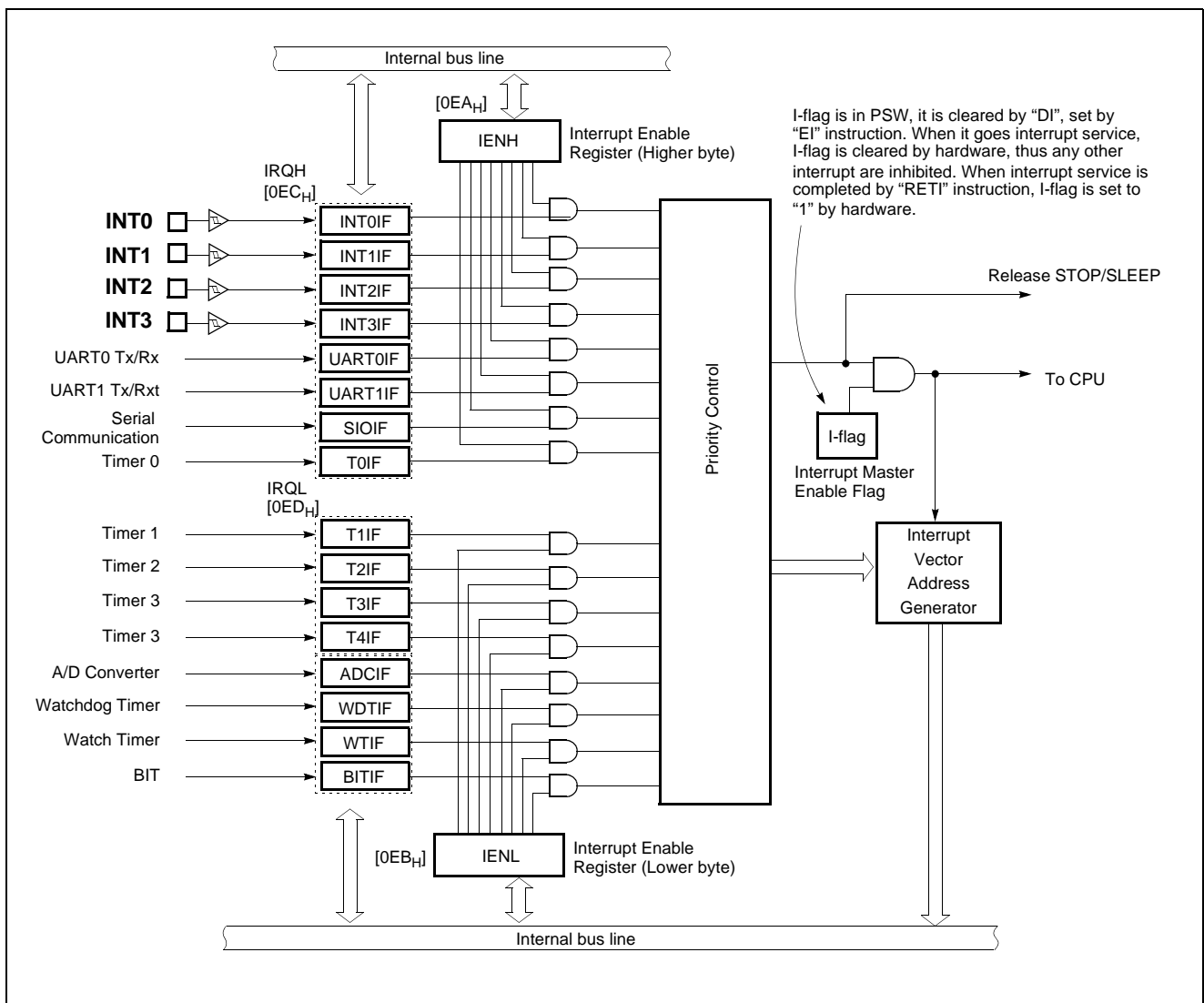

Figure 19-1 Block Diagram of Interrupt

The UART receive/transmit interrupt is generated by UART0IF and UART1IF which are set by completion of UART data reception or transmission.

The SIO interrupt is generated by SIOIF which is set by completion of SIO data reception or transmission.

The interrupts are controlled by the interrupt master enable flag I-flag (bit 2 of PSW on Figure 8-3), the interrupt enable register (IENH, IENL), and the interrupt request flags (in IRQH and IRQL) except Power-on reset and software BRK interrupt. The Table 19-1 shows the Interrupt priority.

Vector addresses are shown in Figure 8-6. Interrupt enable registers are shown in Figure 19-2. These registers are composed of interrupt enable flags of each interrupt source and these flags determines whether an interrupt will be accepted or not. When enable flag is "0", a corresponding interrupt source is prohibited. Note that PSW contains also a master enable bit, I-flag, which disables all interrupts at once.

Reset/Interrupt	Symbol	Priority
Hardware Reset	RESET	1
External Interrupt 0	INT0	2
External Interrupt 1	INT1	3
External Interrupt 2	INT2	4
External Interrupt 3	INT3	5
UART0 Rx/Tx Interrupt	UART0	6
UART1 Rx/Tx Interrupt	UART1	7
Serial Input/Output	SIO	8
Timer/Counter 0	Timer 0	9
Timer/Counter 1	Timer 1	10
Timer/Counter 2	Timer 2	11
Timer/Counter 3	Timer 3	12
Timer/Counter 4	Timer 4	13
ADC Interrupt	ADC	14
Watchdog/Watch Timer	WDT_WT	15
Basic Interval Timer	BIT	16

Table 19-1 Interrupt Priority

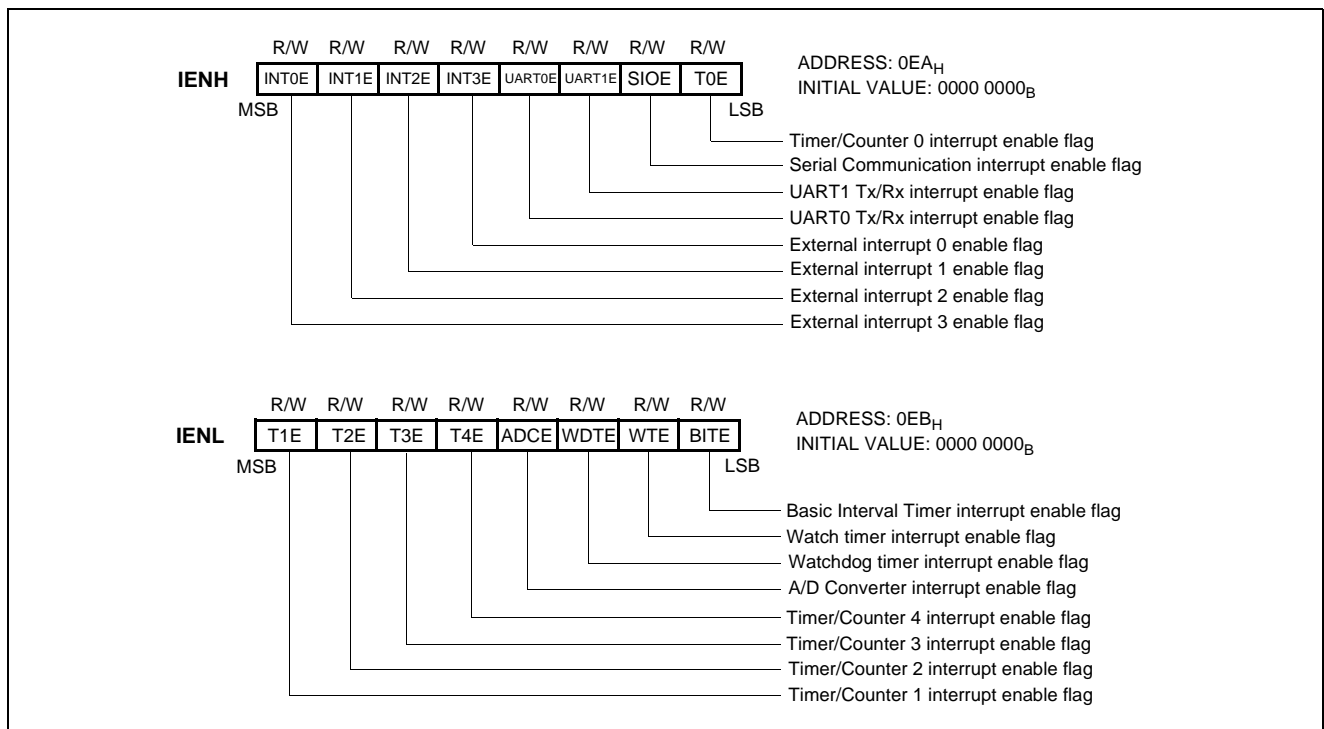

Figure 19-2 Interrupt Enable Flag Register

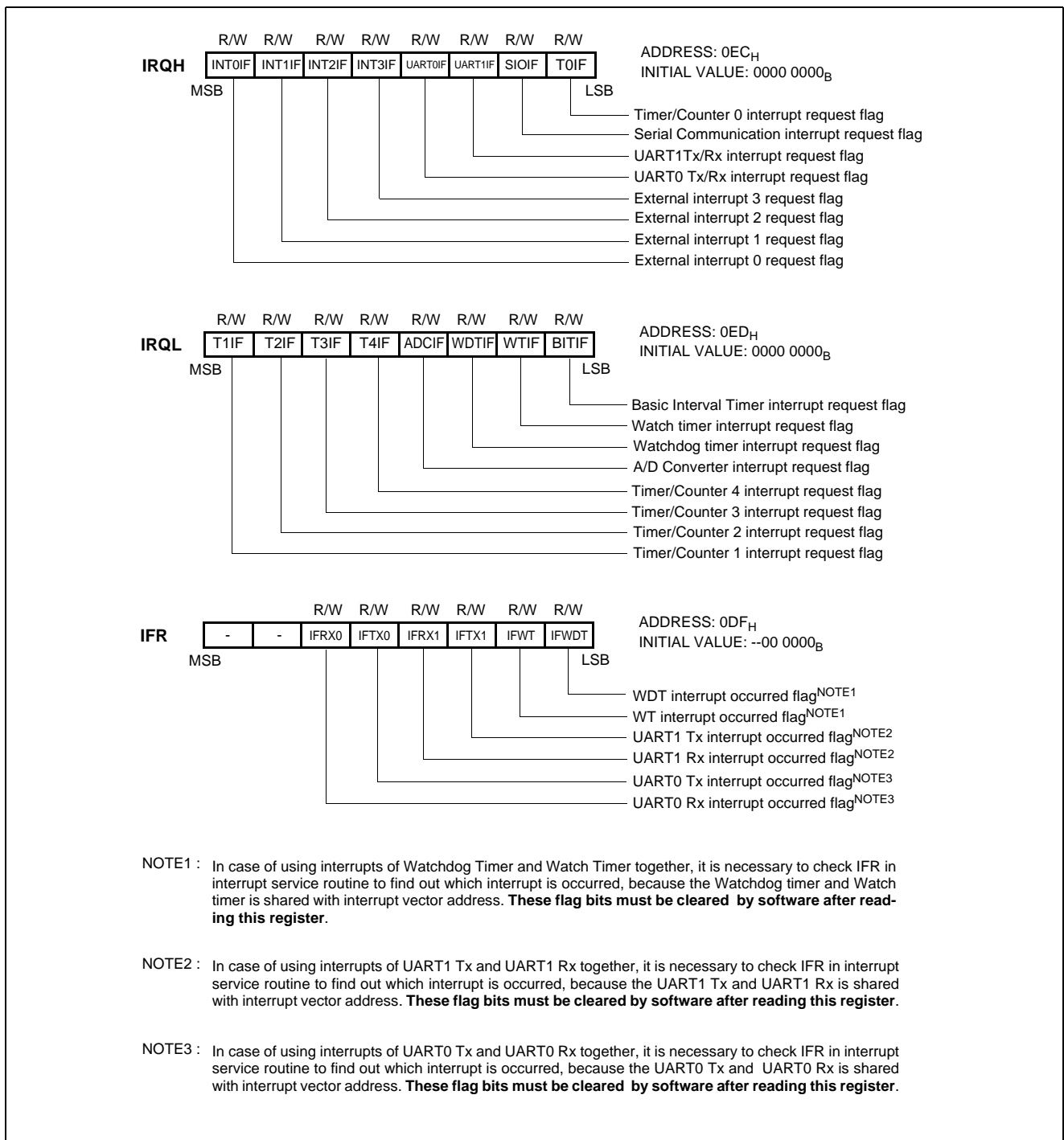

Figure 19-3 Interrupt Request Flag Register

19.1 Interrupt Sequence

An interrupt request is held until the interrupt is accepted or the interrupt latch is cleared to “0” by a reset or an instruction. Interrupt acceptance sequence requires 8 cycles of f_{XIN} ($2\mu s$ at f_{X-}

$f_{IN}=4MHz$) after the completion of the current instruction execution. The interrupt service task is terminated upon execution of an interrupt return instruction [RETI].

19.1.1 Interrupt acceptance

1. The interrupt master enable flag (I-flag) is cleared to "0" to temporarily disable the acceptance of any following maskable interrupts. When a non-maskable interrupt is accepted, the acceptance of any following interrupts is temporarily disabled.
2. Interrupt request flag for the interrupt source accepted is cleared to "0".
3. The contents of the program counter (return address)

and the program status word are saved (pushed) onto the stack area. The stack pointer decreases 3 times.

4. The entry address of the interrupt service program is read from the vector table address and the entry address is loaded to the program counter.
5. The instruction stored at the entry address of the interrupt service program is executed.

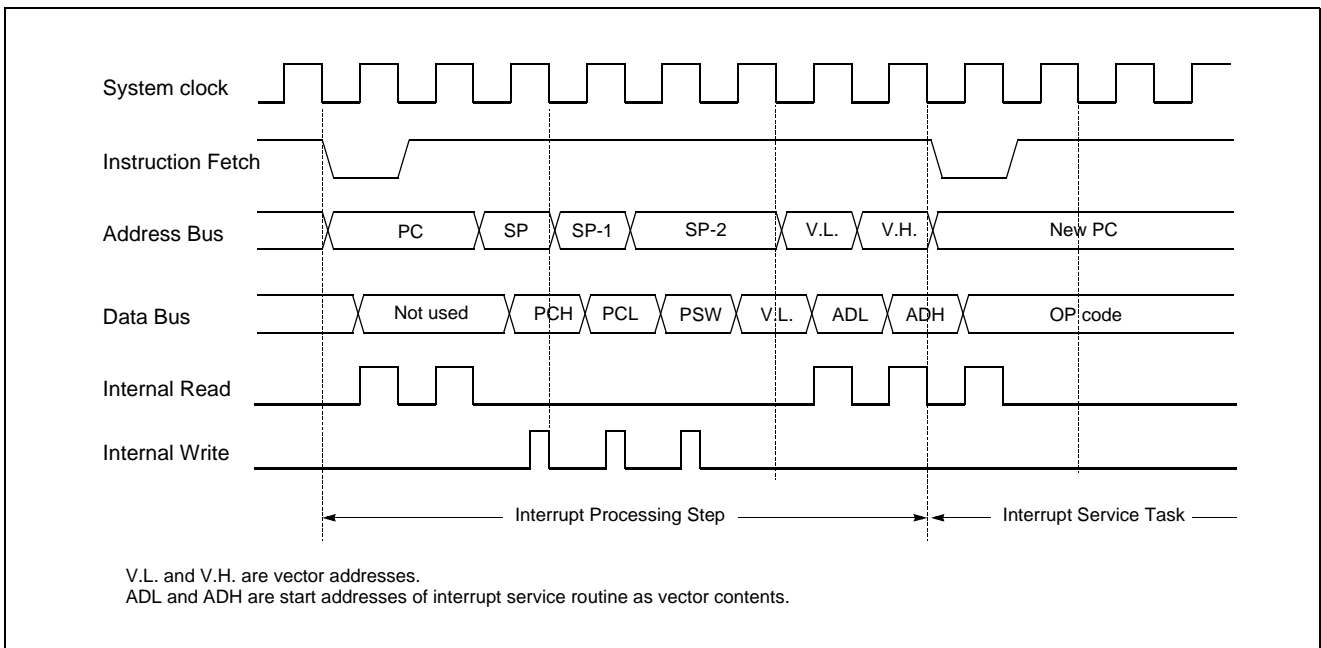

Figure 19-4 Timing chart of Interrupt Acceptance and Interrupt Return Instruction

19.1.2 Saving/Restoring General-purpose Register

During interrupt acceptance processing, the program counter and the program status word are automatically saved on the stack, but accumulator and other registers are not saved itself. These registers are saved by the software if necessary. Also, when multiple interrupt services are nested, it is necessary to avoid using the same data memory area for saving registers.

The following method is used to save/restore the general-purpose registers.

Example: Register save using push and pop instructions

```
INTxx:  PUSH    A      ;SAVE ACC.
        PUSH    X      ;SAVE X REG.
        PUSH    Y      ;SAVE Y REG.
```

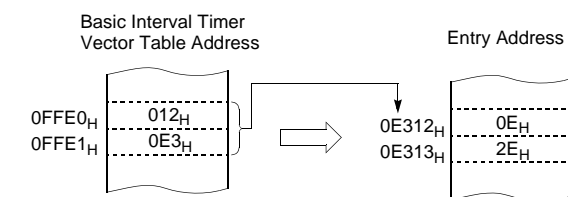
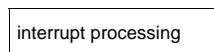

Correspondence between vector table address for BIT interrupt and the entry address of the interrupt service program.

A interrupt request is not accepted until the I-flag is set to "1" even if a requested interrupt has higher priority than that of the current interrupt being serviced.

When nested interrupt service is required, the I-flag should be set to "1" by "EI" instruction in the interrupt service program. In this case, acceptable interrupt sources are selectively enabled by the individual interrupt enable flags.

```

POP     Y     ;RESTORE Y REG.
POP     X     ;RESTORE X REG.
POP     A     ;RESTORE ACC.
RETI                    ;RETURN
    
```

General-purpose register save/restore using push and pop instructions;

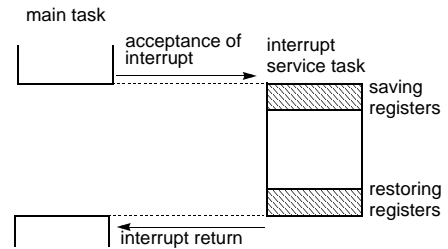

19.2 BRK Interrupt

Software interrupt can be invoked by BRK instruction, which has the lowest priority order.

Interrupt vector address of BRK is shared with the vector of TCALL 0 (Refer to Program Memory Section). When BRK interrupt is generated, B-flag of PSW is set to distinguish BRK from TCALL 0.

Each processing step is determined by B-flag as shown in Figure 19-5.

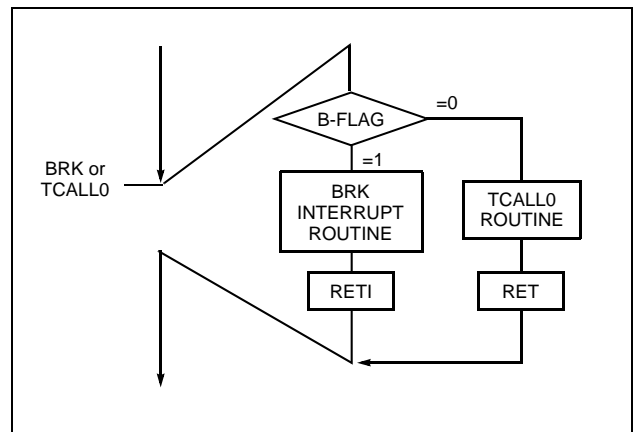

Figure 19-5 Execution of BRK/TCALL0

19.3 Shared Interrupt Vector

In case of using interrupts of Watchdog Timer and Watch Timer together, it is necessary to check IFR in interrupt service routine to find out which interrupt is occurred, because the Watchdog timer and Watch timer is shared with interrupt vector address. These flag bits must be cleared by software after reading this register.

In case of using interrupts of UART0 Tx and UART0 Rx together, it is necessary to check IFR in interrupt service routine to find out which interrupt is occurred, because the UART0 Tx and

UART0 Rx is shared with interrupt vector address. These flag bits must be cleared by software after reading this register.

In case of using interrupts of UART1 Tx and UART1 Rx together, it is necessary to check IFR in interrupt service routine to find out which interrupt is occurred, because the UART1 Tx and UART1 Rx is shared with interrupt vector address. These flag bits must be cleared by software after reading this register. Each processing step is determined by IFR as shown in Figure 19-6.

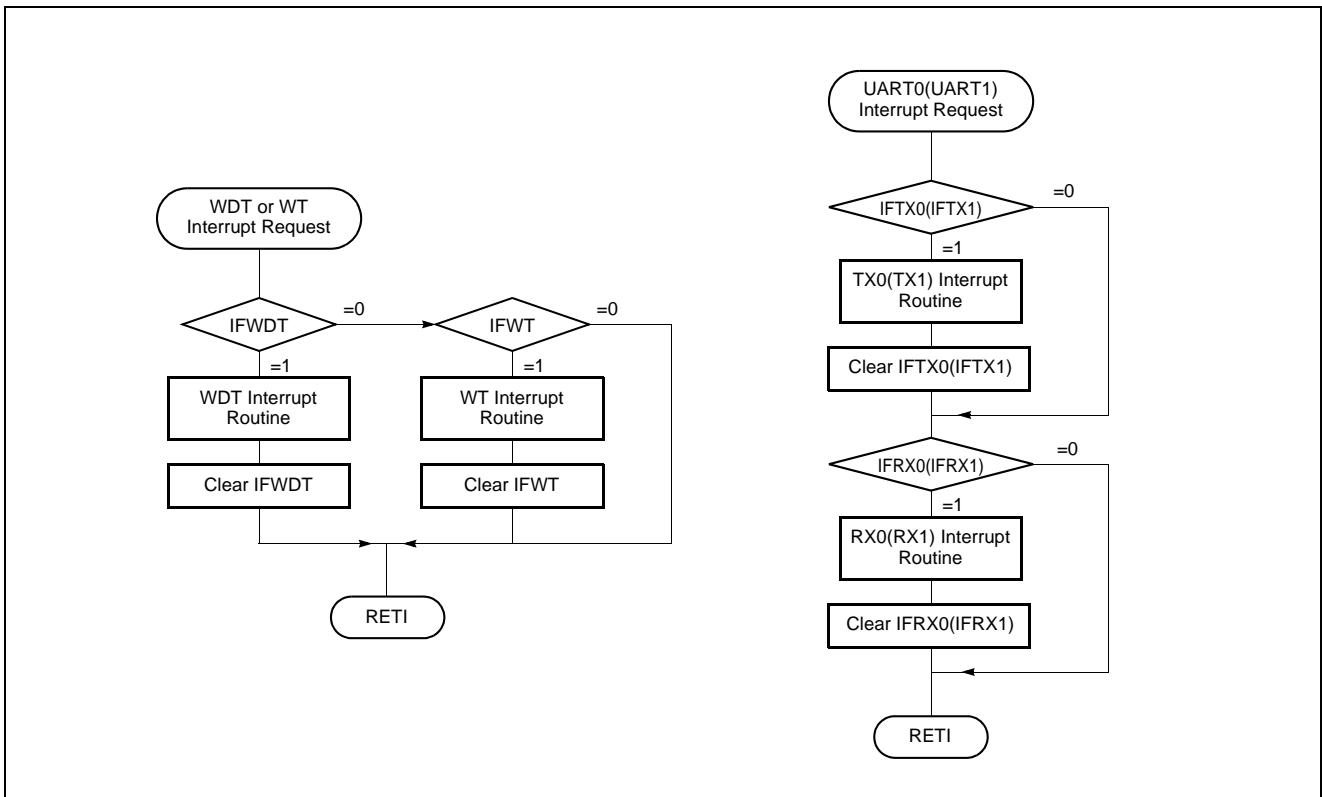

Figure 19-6 Software Flowchart of Shared Interrupt Vector

19.4 Multi Interrupt

If two interrupt requests of different priority level are received simultaneously, the request of higher priority level is serviced. If interrupt requests of equal priority level are received at the same time simultaneously, an internal polling sequence determines by hardware which request is serviced.

However, multiple processing through software for special features is possible. Generally when an interrupt is accepted, the I-flag is cleared to disable any further interrupt. But as user sets I-flag in interrupt routine, some further interrupt can be serviced even if certain interrupt is in progress. Refer to Figure 19-7.

Example: During Timer1 interrupt is in progress, INTO interrupt serviced without any suspend.

```
TIMER1:  PUSH  A
          PUSH  X
```

```
PUSH  Y
LDM   IENH, #80H ; Enable INTO only
LDM   IENL, #0   ; Disable other int.
EI    ; Enable Interrupt
:
:
:
:
:
LDM   IENH, #0FFH ; Enable all interrupts
LDM   IENL, #0FFH
POP   Y
POP   X
POP   A
RETI
```

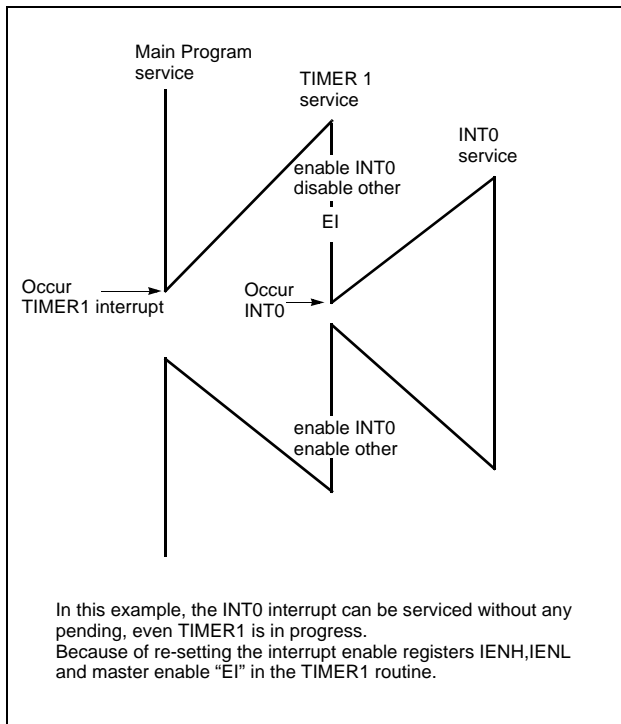

Figure 19-7 Execution of Multi Interrupt

19.5 External Interrupt

The external interrupt on INT0, INT1, INT2 and INT3 pins are edge triggered depending on the edge selection register IEDS (address 0EEH) as shown in Figure 19-8.

The edge detection of external interrupt has three transition activated mode: rising edge, falling edge, and both edge.

INT0 ~ INT3 are multiplexed with general I/O ports (R10, R11, R12, R50). To use as an external interrupt pin, the bit of port selection register PSR0 should be set to "1" correspondingly.

Example: To use as an INT0 and INT2

```

:
;**** Set external interrupt port as pull-up state.
LDM    PU1, #0000_0101B
;
;**** Set port as an external interrupt port
LDM    PSR0, #0000_0101B
;
;**** Set Falling-edge Detection
LDM    IEDS, #0001_0001B
:
    
```

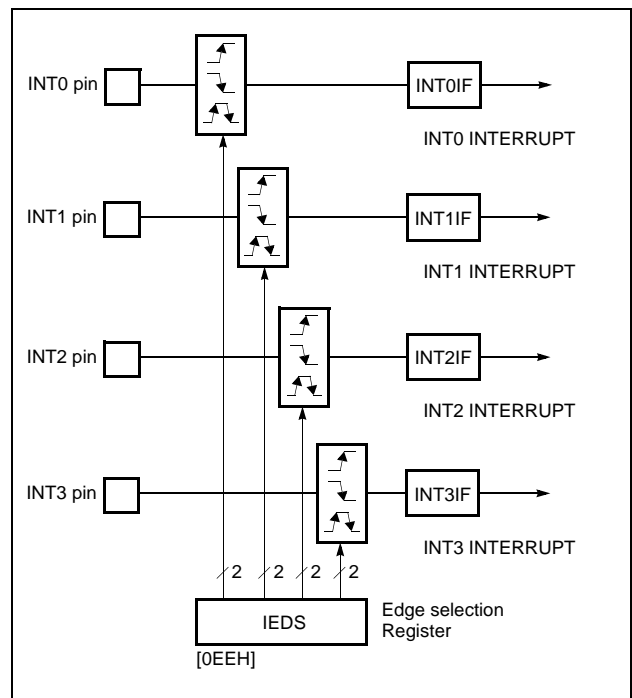

Figure 19-8 External Interrupt Block Diagram

Response Time

The INT0 ~ INT3 edge are latched into INT0IF ~ INT3IF at every machine cycle. The values are not actually polled by the circuitry until the next machine cycle. If a request is active and conditions are right for it to be acknowledged, a hardware subroutine call to the requested service routine will be the next instruction to be executed. The DIV itself takes twelve cycles. Thus, a minimum of

twelve complete machine cycles elapse between activation of an external interrupt request and the beginning of execution of the first instruction of the service routine.

Figure 19-9 shows interrupt response timings.

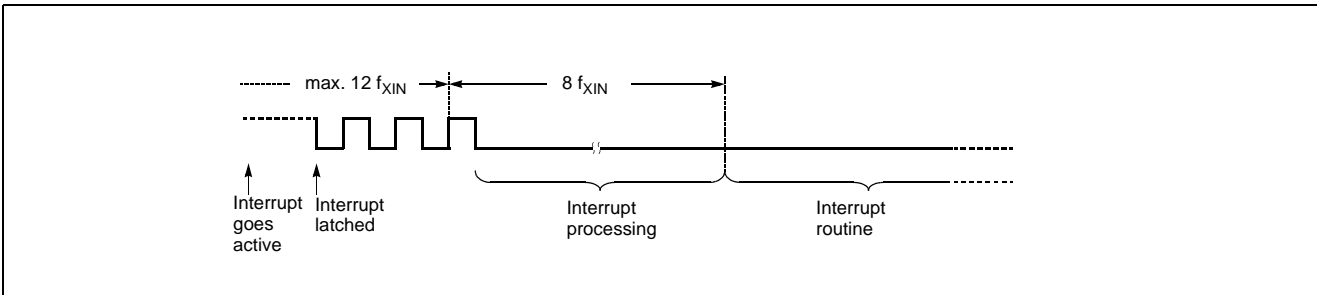

Figure 19-9 Interrupt Response Timing Diagram

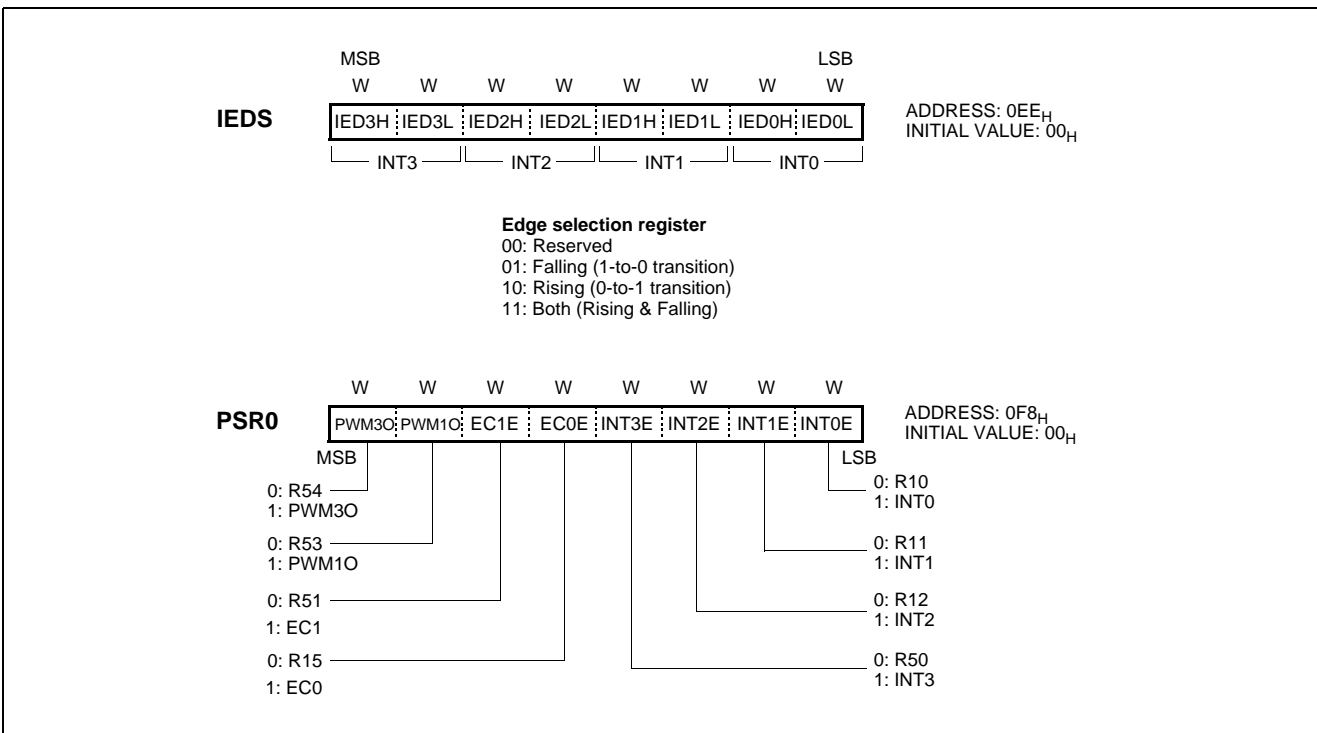

Figure 19-10 IEDS register and Port Selection Register PSR0

20. OPERATION MODE

The system clock controller starts or stops the main-frequency clock oscillator and switches between the main and sub frequency clock. The operating mode is generally divided into the main active mode, the sub active mode 1 and sub active mode 2, which are controlled by System clock control register (SCMR). Figure 20-1 shows the operating mode transition diagram.

System clock control is performed by the system clock mode register, SCMR. During reset, this register is initialized to "0" so that the main-clock operating mode is selected.

Main Active mode

This mode is fast-frequency operating mode. The CPU and the peripheral hardware are operated on the high-frequency clock. At reset release, this mode is invoked.

Sub Active mode

This mode is low-frequency operating mode. In this mode, the CPU and the peripheral hardware clock are provided by low-frequency clock oscillation, so power consumption can be reduced.

SLEEP mode

In this mode, the CPU clock stops while peripherals and the oscillation source continues to operate normally.

STOP mode

In this mode, the system operations are all stopped, holding the internal states valid immediately before the stop at the low power consumption level. The main oscillation source stops, but the sub clock oscillation and watch timer by sub clock and RC-oscillated watchdog timer don't stop.

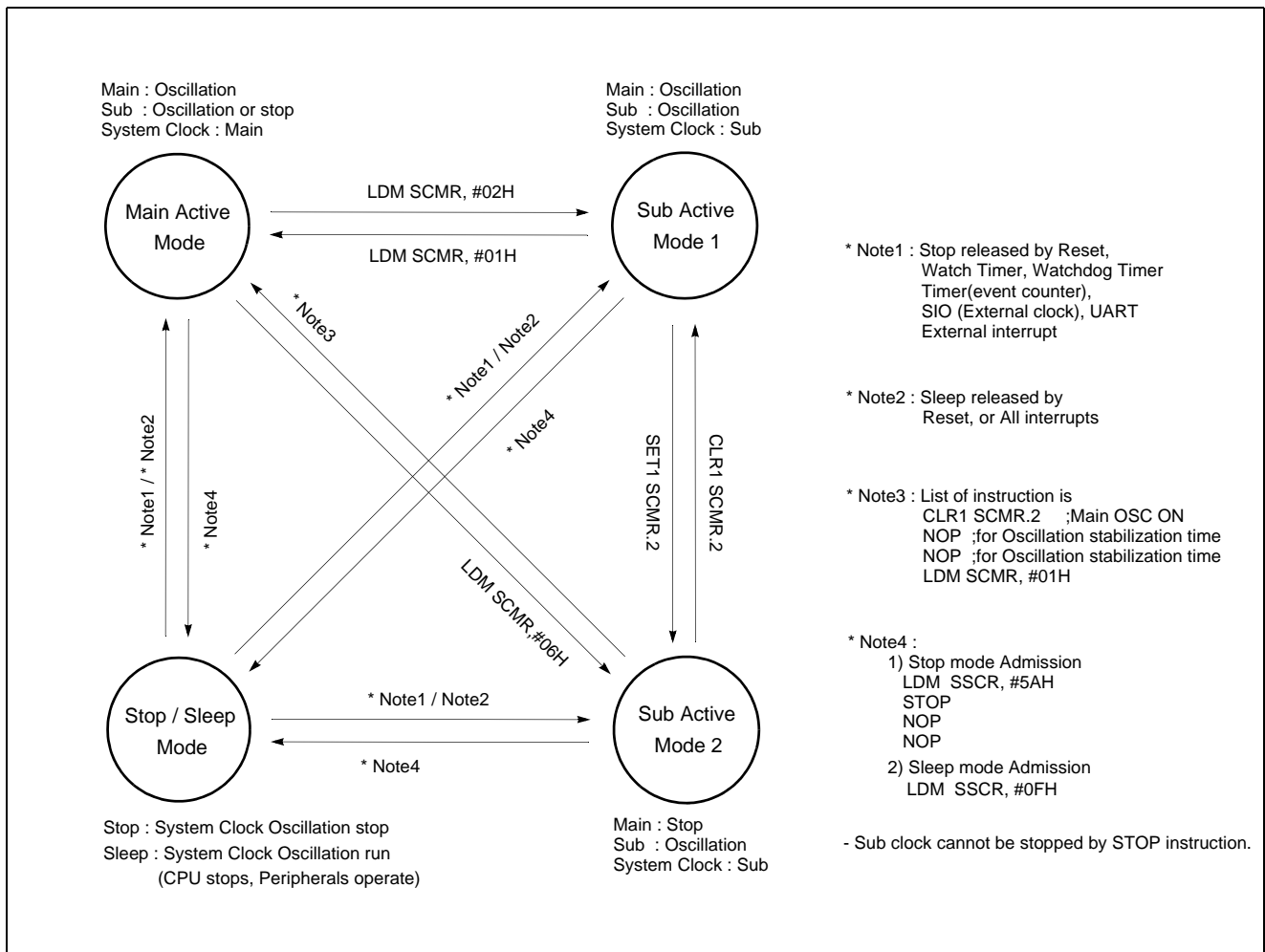

Figure 20-1 Operating Mode

20.1 Operation Mode Switching

In the Main active mode, only the high-frequency clock oscillator is used. In the Sub active mode, the low-frequency clock oscillation is used, so the low power voltage operation or the low power consumption operation can be enabled. Instruction execution does not stop during the change of operation mode. In this case, some peripheral hardware capabilities may be affected. For details, refer to the description of the relevant operation.

The following describes the switching between the Main active mode and the Sub active mode. During reset, the system clock mode register is initialized at the Main active mode. It must be set to the Sub active mode for reducing the power consumption.

Switching from Main active to Sub active 1

First, write "02_H" into SCMR to switch the main system clock to the sub-frequency clock of Sub Active mode 1.

Example:

```
LDM    SCMR,#02H ;Switch to sub active1
```

Switching from Main active to Sub active 2

First, write "06_H" into SCMR to switch the main system clock to the sub-frequency clock of Sub Active mode 2.

Example:

```
LDM    SCMR,#06H ;Switch to sub active2
```

Returning from Sub active 1 to Main active

First, write "01_H" into SCMR to turn on the main-frequency oscillation. Sub active mode can also be released by setting the $\overline{\text{RESET}}$ pin to low, which immediately performs the reset operation. After reset, the MC80F0424/0432/0448 is placed in Main active mode.

Example:

```
LDM    SCMR,#01H ;Switch to main-clock
```

Switching from Sub active 1 to Sub active 2

First, set SCMR.2 to switch the main system clock to the sub-frequency clock of Sub Active mode 2.

Example:

```
SET1   SCMR.2 ;Switch to sub active2
```

Returning from Sub active 2 to Main active

First, set the SCMR.2 bit clear, and wait for a while for oscillation stabilization time. Secondly, write "01_H" into the SCMR to turn on the main-frequency oscillation. This time, the stabilization (warm-up) time needs to be taken by the software delay routine

with the length of two or more NOP instruction. Sub active mode can also be released by setting the $\overline{\text{RESET}}$ pin to low, which immediately performs the reset operation. After reset, the MC80F0424/0432/0448 is placed in Main active mode.

Example:

```
CLR1   SCMR.2 ;Turn on main-clock
NOP    ;for OSC stabilization time
NOP    ;for OSC stabilization time
LDM    SCMR,#01h ;Move to main active
```

Returning from Sub active 2 to Sub active 1

First, clear SCMR.2 to switch the main system clock to the sub-frequency clock of Sub Active mode 2.

Example:

```
CLR1   SCMR.2 ;Switch to sub active1
```

Shifting from the Normal operation to the SLEEP mode

If the SLEEP mode is invoked, the external clock oscillation does not stop but the CPU clock stops while other peripherals are operate normally.

The ways of release from this mode are by setting the $\overline{\text{RESET}}$ pin to low and all available interrupts. For more detail, See "21. POWER SAVING OPERATION" on page 101.

Shifting from the Normal operation to the STOP mode

If the STOP mode is invoked, the main-frequency clock oscillation stops and the CPU clock stops and other peripherals are stop too. But sub-frequency clock oscillation operate continuously if enabled previously. After the STOP operation is released by reset, the operation mode is changed to Main active mode.

The methods of release from this mode are Reset, Watch Timer, RC watchdog timer, Event counter, SIO(External clock), UART, and External Interrupt.

For more details, see "21. POWER SAVING OPERATION" on page 101.

Note: In the STOP and SLEEP operating modes, the power consumption by the oscillator and the internal hardware is reduced. However, the power for the pin interface (depending on external circuitry and program) is not directly associated with the low-power consumption operation. This must be considered in system design as well as interface circuit design.

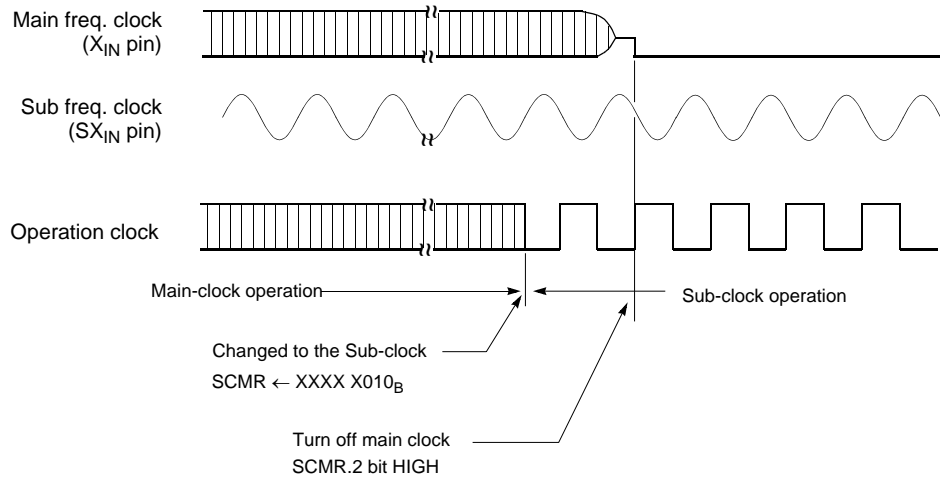

(a) Main active mode → Sub active mode 1 → Sub active mode 2

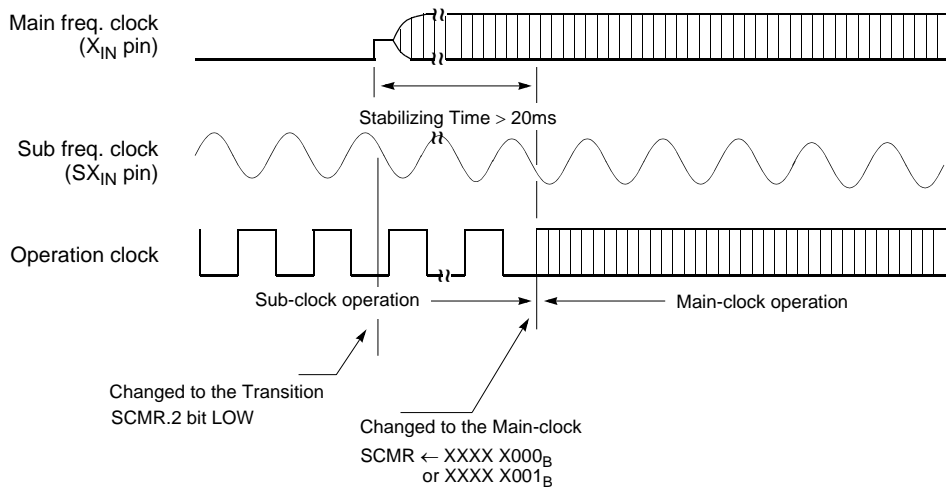

(b) Sub active mode 2 → Sub active mode 1 → Main active mode

Figure 20-2 System Clock Switching Timing

21. POWER SAVING OPERATION

The MC80F0424/0432/0448 has two power-down modes. In power-down mode, power consumption is reduced considerably. For applications where power consumption is a critical factor, device provides two kinds of power saving functions, STOP mode

and SLEEP mode. Table 21-1 shows the status of each Power Saving Mode. SLEEP mode is entered by the SSCR register to "0Fh", and STOP mode is entered by STOP instruction after the SSCR register to "5Ah".

21.1 Sleep Mode

In this mode, the internal oscillation circuits remain active and oscillation continues and peripherals are operate normally, but CPU stops. Movement of all peripherals is shown in Table 21-1. SLEEP mode is entered by setting the SSCR register to "0Fh". It

is released by Reset or interrupt. To be released by interrupt, interrupt should be enabled before SLEEP mode.

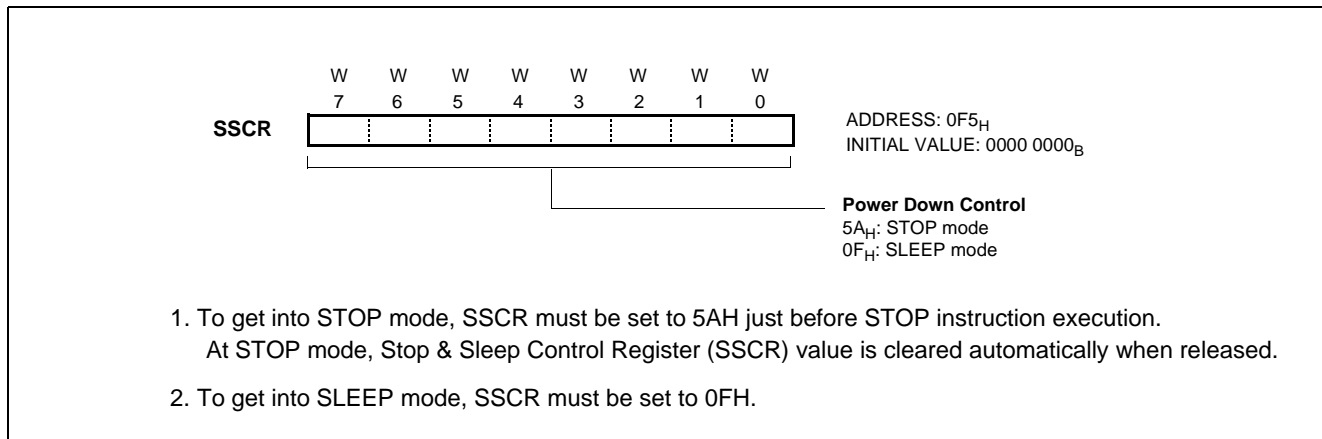

Figure 21-1 STOP and SLEEP Control Register

Release the SLEEP mode

The exit from SLEEP mode is hardware reset or all interrupts. Reset re-defines all the Control registers but does not change the on-chip RAM. Interrupts allow both on-chip RAM and Control registers to retain their values.

If I-flag = 1, the normal interrupt response takes place. If I-flag = 0, the chip will resume execution starting with the instruction following the SLEEP instruction. It will not vector to interrupt service routine. (refer to Figure 21-4)

When exit from SLEEP mode by reset, enough oscillation stabilization time is required to normal operation. Figure 21-3 shows the timing diagram. his guarantees that oscillator has started and stabilized. By interrupts, exit from SLEEP mode is shown in Figure 21-2. By reset, exit from SLEEP mode is shown in Figure 21-3.

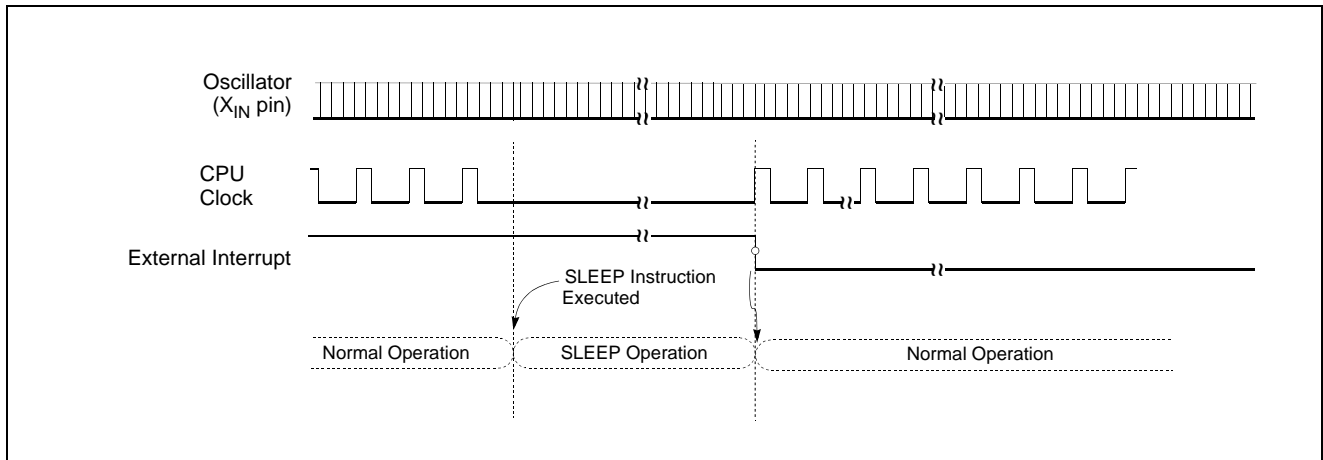

Figure 21-2 SLEEP Mode Release Timing by External Interrupt

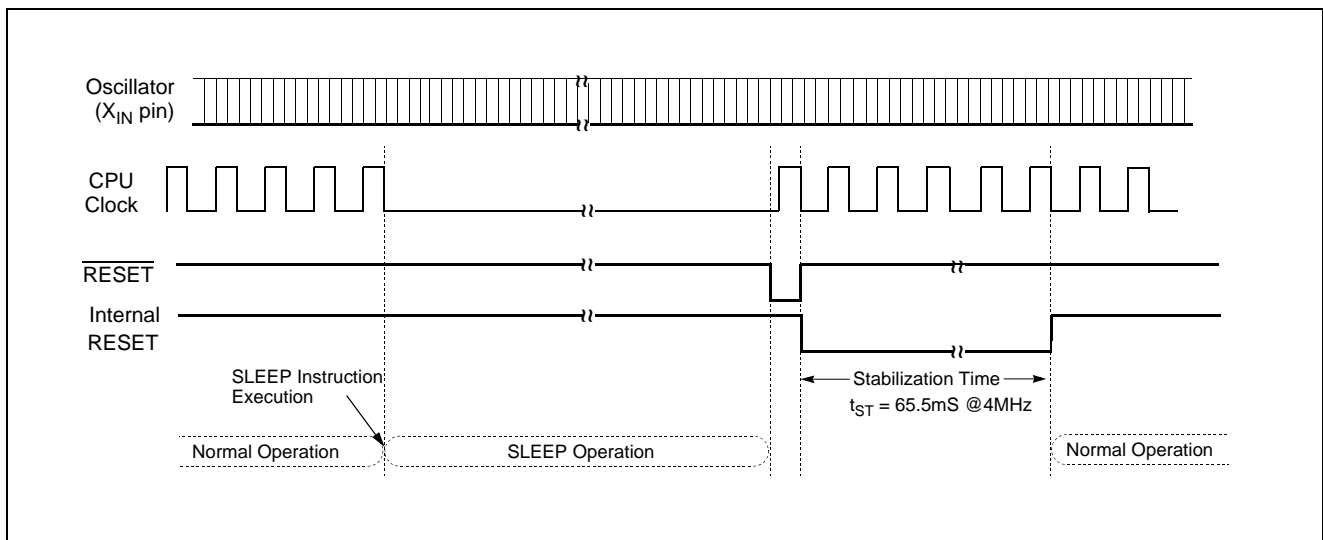

Figure 21-3 Timing of SLEEP Mode Release by Reset

21.2 Stop Mode

In the Stop mode, the main oscillator, system clock and peripheral clock is stopped, but the sub clock oscillation and Watch Timer by sub clock and RC-oscillated watchdog timer continue to operate. With the clock frozen, all functions are stopped, but the on-chip RAM and Control registers are held. The port pins out the values held by their respective port data register, port direction registers. Oscillator stops and the systems internal operations are all held up.

- The states of the RAM, registers, and latches valid immediately before the system is put in the STOP state are all held.
- The program counter stop the address of the instruction to be executed after the instruction

"STOP" which starts the STOP operating mode.

Note: The Stop mode is activated by execution of STOP instruction after setting the SSCR to "5A_H". (This register should be written by byte operation. If this register is set by bit manipulation instruction, for example "set1" or "clr1" instruction, it may be undesired operation)

In the Stop mode of operation, V_{DD} can be reduced to minimize power consumption. Care must be taken, however, to ensure that V_{DD} is not reduced before the Stop mode is invoked, and that V_{DD} is restored to its normal operating level, before the Stop mode is terminated.

The reset should not be activated before V_{DD} is restored to its normal operating level, and must be held active long enough to allow the oscillator to restart and stabilize.

Note: After STOP instruction, at least two or more NOP instruction should be written.

```
Ex)    LDM CKCTLR,#0FH ;more than 20ms
        LDM SSCR,#5AH
        STOP
        NOP ;for stabilization time
        NOP ;for stabilization time
```

with the oscillator and the internal hardware is lowered; however, the power dissipation associated with the pin interface (depending on the external circuitry and program) is not directly determined by the hardware operation of the STOP feature. This point should be little current flows when the input level is stable at the power voltage level (V_{DD}/V_{SS}); however, when the input level gets higher than the power voltage level (by approximately 0.3 to 0.5V), a current begins to flow. Therefore, if cutting off the output transistor at an I/O port puts the pin signal into the high-impedance state, a current flow across the ports input transistor, requiring to fix the level by pull-up or other means.

In the STOP operation, the dissipation of the power associated

Peripheral	STOP Mode	SLEEP Mode
CPU	Stop	Stop
RAM	Retain	Retain
Basic Interval Timer	Halted (Only operates in RC-WDT mode)	Operates Continuously
Watchdog Timer	Stop (Only operates in RC-WDT mode)	Stop
Watch Timer	Stop (Only operates in Subclock mode)	Stop
Timer/Counter	Halted(Only when the event counter mode is enabled, timer operates normally)	Operates Continuously
Buzzer, ADC	Stop	Stop
SIO	Only operate with external clock	Only operate with external clock
UART	Only operate with external clock	Only operate with external clock
Oscillator	Stop($X_{IN}=L, X_{OUT}=H$)	Oscillation
Sub Oscillator	Oscillation	Oscillation
I/O Ports	Retain	Retain
Control Registers	Retain	Retain
Internal Circuit	Stop mode	Sleep mode
Prescaler	Retain	Active
Address Data Bus	Retain	Retain
Release Source	Reset, Timer(EC0, EC1), RC WDT Timer, Watch Timer(Subclock), SIO(ext. clock), UART, External Interrupt	Reset, All Interrupts

Table 21-1 Peripheral Operation During Power Saving Mode

Release the STOP mode

The source for exit from STOP mode is hardware reset, external interrupt, Timer(Event Counter), Watchdog Timer(RCWDT), Watch Timer(by subclock), SIO(by external clock) or UART. Reset re-defines all the Control registers but does not change the on-chip RAM. External interrupts allow both on-chip RAM and Control registers to retain their values.

If I-flag = 1, the normal interrupt response takes place. If I-flag = 0, the chip will resume execution starting with the instruction fol-

lowing the STOP instruction. It will not vector to interrupt service routine. (refer to Figure 21-4)

When exit from Stop mode by external interrupt, enough oscillation stabilization time is required to normal operation. Figure 21-5 shows the timing diagram. When released from the Stop mode, the Basic interval timer is activated on wake-up. It is increased from 00_H until FF_H . The count overflow is set to start normal operation. Therefore, before STOP instruction, user must set its relevant prescaler divide ratio to have long enough time (more than

20msec). This guarantees that oscillator has started and stabilized.

By reset, exit from Stop mode is shown in Figure 21-6.

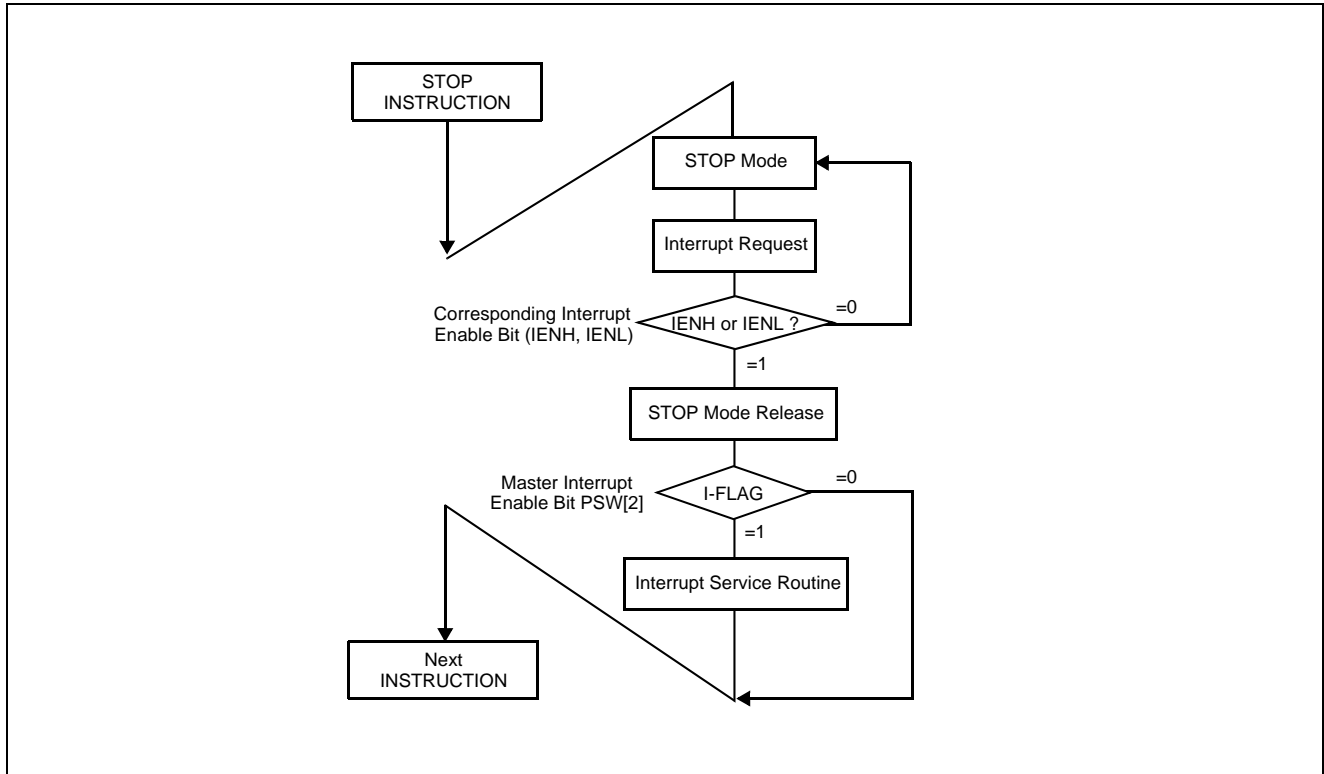

Figure 21-4 STOP Releasing Flow by Interrupts

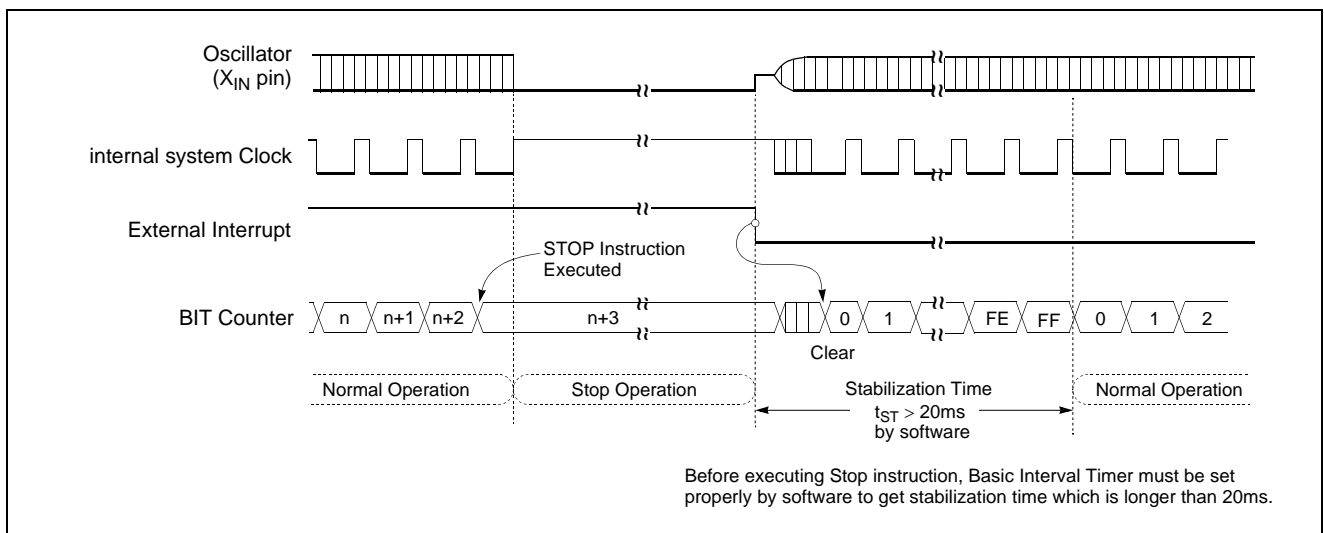

Figure 21-5 STOP Mode Release Timing by External Interrupt

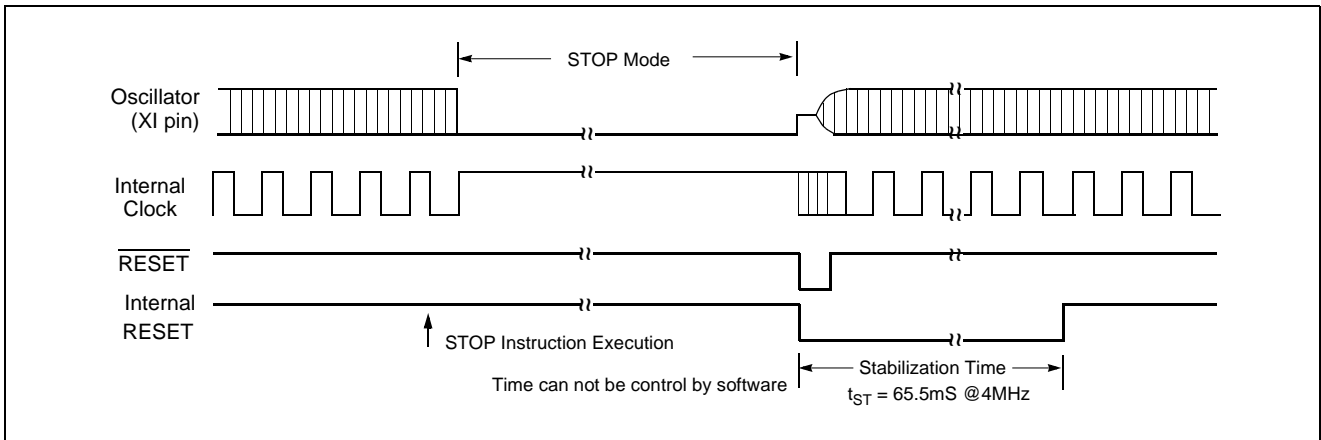

Figure 21-6 Timing of STOP Mode Release by Reset

21.3 Stop Mode at Internal RC-Oscillated Watchdog Timer Mode

In the Internal RC-Oscillated Watchdog Timer mode, the on-chip oscillator is stopped. But internal RC oscillation circuit is oscillated in this mode. The on-chip RAM and Control registers are held. The port pins out the values held by their respective port data register, port direction registers.

The Internal RC-Oscillated Watchdog Timer mode is activated by execution of STOP instruction after setting the bit RCWDT of CKCTLR to "1". (This register should be written by byte operation. If this register is set by bit manipulation instruction, for example "set1" or "clr1" instruction, it may be undesired operation)

Note: Caution: After STOP instruction, at least two or more NOP instruction should be written

```
Ex)  LDM WDTR,#1111_1111B
      LDM CKCTLR,#0010_1110B
      LDM SSCR,#0101_1010B
      STOP
      NOP ;for stabilization time
      NOP ;for stabilization time
```

The exit from Internal RC-Oscillated Watchdog Timer mode is hardware reset or external interrupt including RC watchdog tim-

er. Reset re-defines all the Control registers but does not change the on-chip RAM. External interrupts allow both on-chip RAM and Control registers to retain their values.

If I-flag = 1, the normal interrupt response takes place. In this case, if the bit WDTON of CKCTLR is set to "0" and the bit WDTE of IENH is set to "1", the device will execute the watchdog timer interrupt service routine(Figure 8-6). However, if the bit WDTON of CKCTLR is set to "1", the device will generate the internal Reset signal and execute the reset processing(Figure 21-8). If I-flag = 0, the chip will resume execution starting with the instruction following the STOP instruction. It will not vector to interrupt service routine.(refer to Figure 21-4)

When exit from Stop mode at Internal RC-Oscillated Watchdog Timer mode by external interrupt, the oscillation stabilization time is required to normal operation. Figure 21-7 shows the timing diagram. When release the Internal RC-Oscillated Watchdog Timer mode, the basic interval timer is activated on wake-up. It is increased from 00_H until FF_H. The count overflow is set to start normal operation. Therefore, before STOP instruction, user must be set its relevant prescaler divide ratio to have long enough time (more than 20msec). This guarantees that oscillator has started and stabilized. By reset, exit from internal RC-Oscillated Watchdog Timer mode is shown in Figure 21-8.

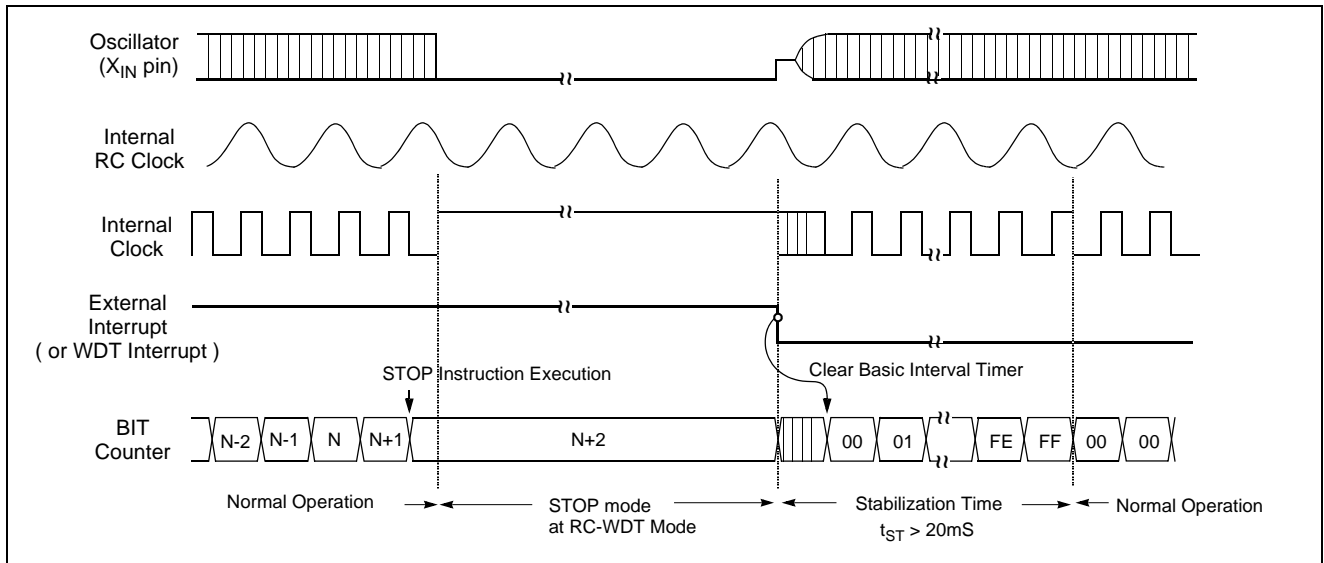

Figure 21-7 Stop Mode Release at Internal RC-WDT Mode by External Interrupt or WDT Interrupt

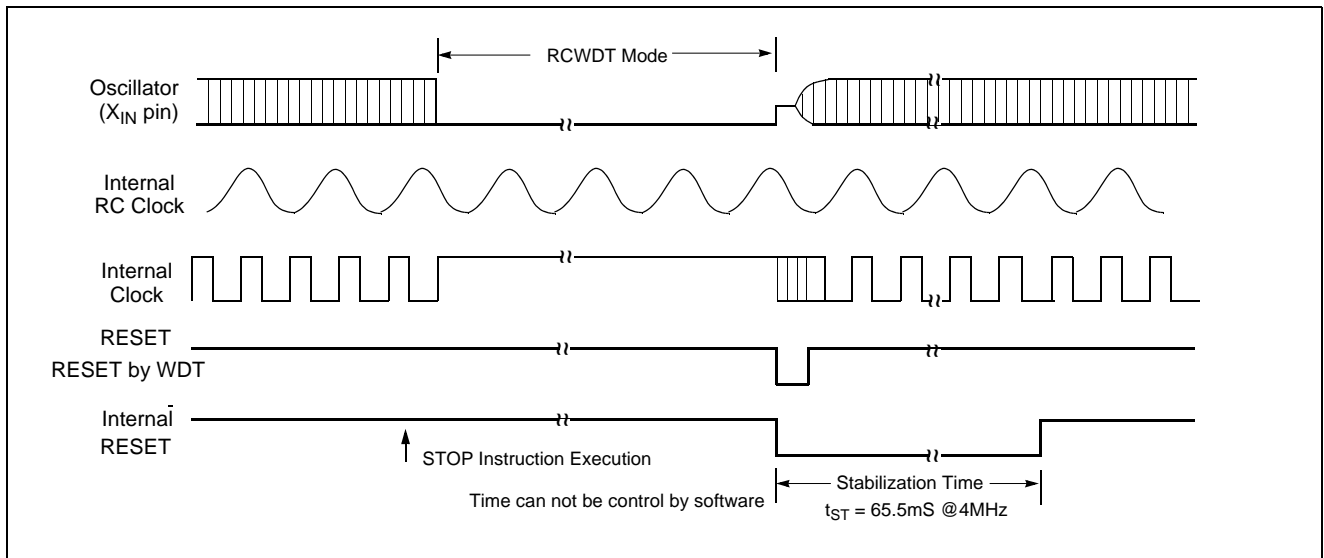

Figure 21-8 Internal RC-WDT Mode Releasing by Reset

21.4 Minimizing Current Consumption

The Stop mode is designed to reduce power consumption. To minimize current drawn during Stop mode, the user should turn-

off output drivers that are sourcing or sinking current, if it is practical.

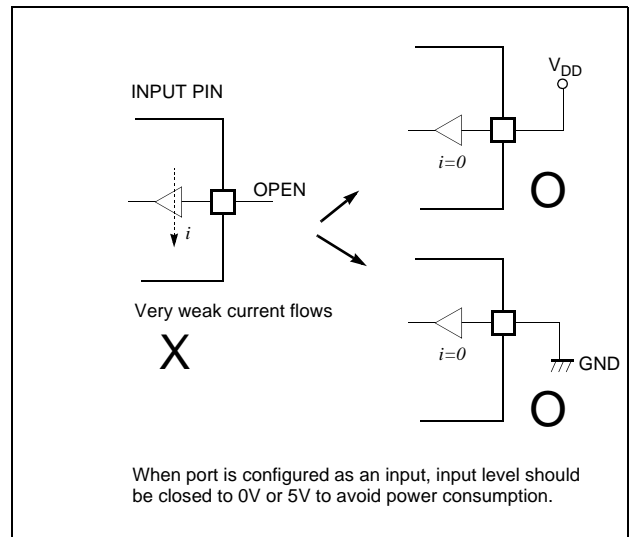
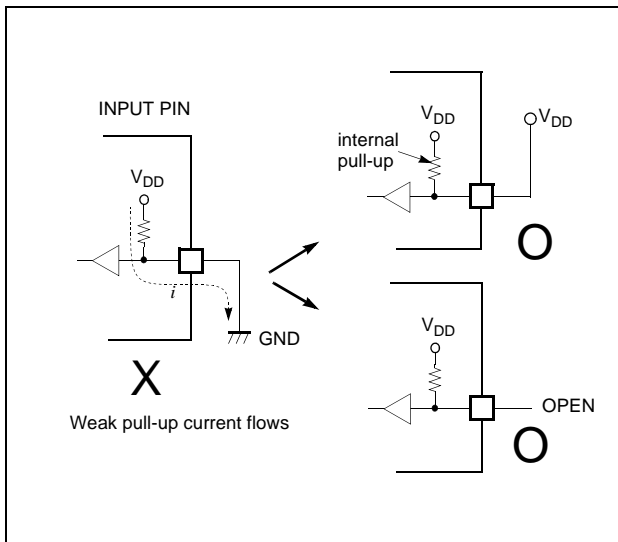

Figure 21-9 Application Example of Unused Input Port

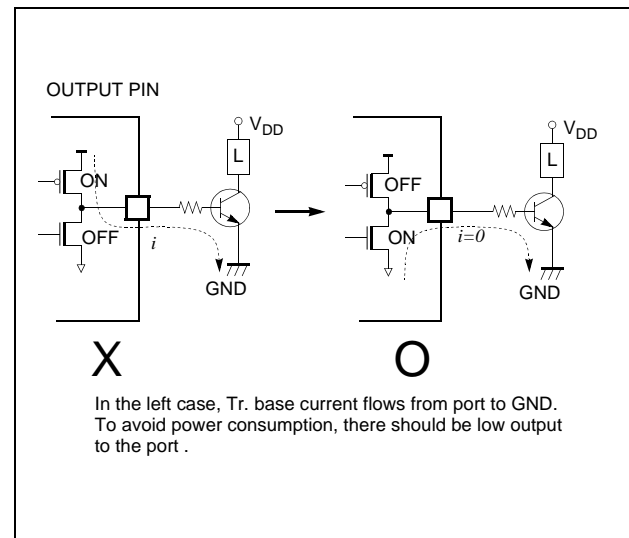
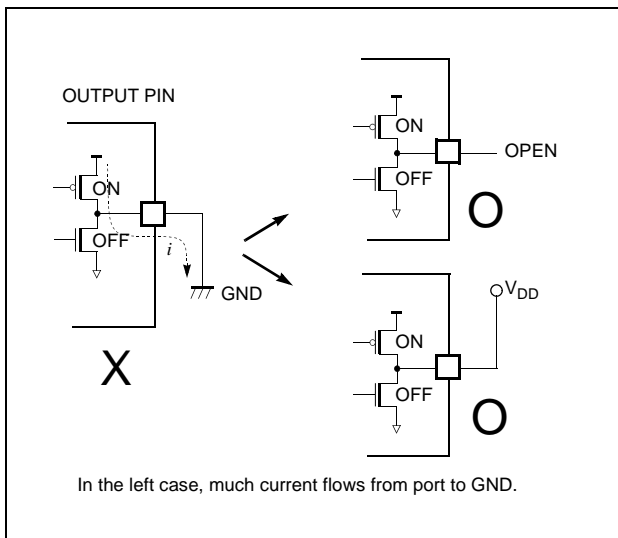

Figure 21-10 Application Example of Unused Output Port

Note: In the STOP operation, the power dissipation associated with the oscillator and the internal hardware is lowered; however, the power dissipation associated with the pin interface (depending on the external circuitry and program) is not directly determined by the hardware operation of the STOP feature. This point should be little current flows when the input level is stable at the power voltage level (V_{DD}/V_{SS}); however, when the input level becomes higher

than the power voltage level (by approximately 0.3V), a current begins to flow. Therefore, if cutting off the output transistor at an I/O port puts the pin signal into the high-impedance state, a current flow across the ports input transistor, requiring it to fix the level by pull-up or other means.

It should be set properly in order that current flow through port doesn't exist.

First consider the port setting to input mode. Be sure that there is

no current flow after considering its relationship with external circuit. In input mode, the pin impedance viewing from external MCU is very high that the current doesn't flow.

But input voltage level should be V_{SS} or V_{DD} . Be careful that if unspecified voltage, i.e. if uncertain voltage level (not V_{SS} or V_{DD}) is applied to input pin, there can be little current (max. 1mA at around 2V) flow.

If it is not appropriate to set as an input mode, then set to output mode considering there is no current flow. The port setting to High or Low is decided by considering its relationship with external circuit. For example, if there is external pull-up resistor then it is set to output mode, i.e. to High, and if there is external pull-down register, it is set to low.

22. OSCILLATOR CIRCUIT

The MC80F0424/0432/0448 has two oscillation circuits internally. X_{IN} and X_{OUT} are input and output for frequency, and SX_{IN} and SX_{OUT} are input and output for sub frequency, respectively, inverting amplifier which can be configured for being used as an on-chip oscillator, as shown in Figure 22-1.

Note: When using the sub clock oscillation, connect a resistor in series with R which is shown as below Figure 22-1. In order to reduce the power consumption, the sub clock oscillator employs a low amplification factor circuit. Because of this, the sub clock oscillator is more sensitive to noise than the main system clock oscillator.

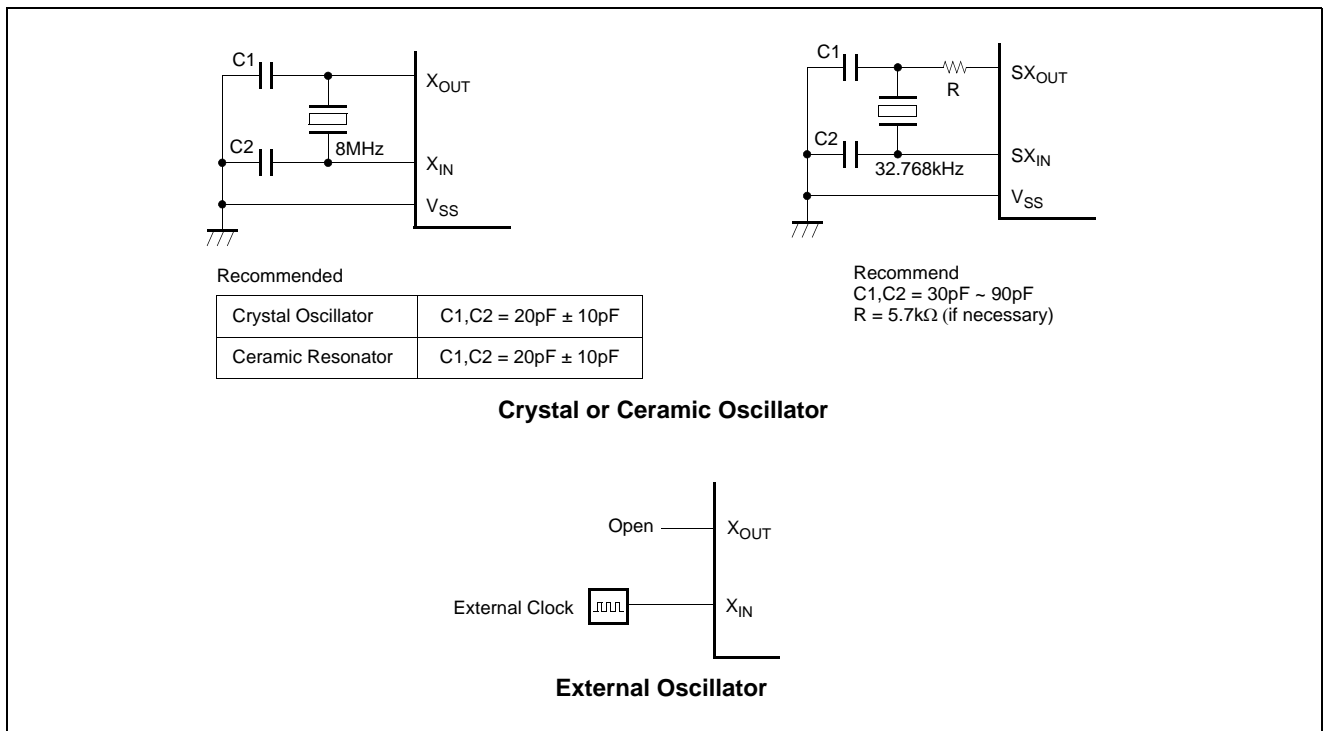

Figure 22-1 Oscillation Circuit

Oscillation circuit is designed to be used either with a ceramic resonator or crystal oscillator. Since each crystal and ceramic resonator have their own characteristics, the user should consult the crystal manufacturer for appropriate values of external components.

In addition, see Figure 22-2 for the layout of the crystal.

Note: Minimize the wiring length. Do not allow the wiring to intersect with other signal conductors. Do not allow the wiring to come near changing high current. Set the potential of the grounding position of the oscillator capacitor to that of V_{SS} . Do not ground it to any ground pattern where high current is present. Do not fetch signals from the oscillator.

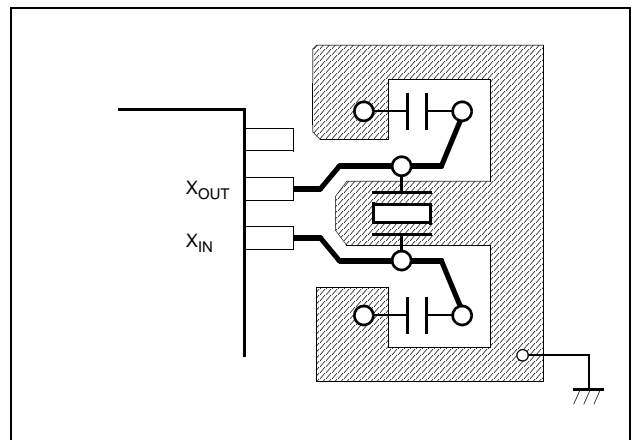

Figure 22-2 Layout of Oscillator PCB circuit

23. RESET

The MC80F0424/0432/0448 have four types of reset generation procedures; they are an external reset input, a watch-dog timer re-

set, power fail processor reset, and address fail reset. Table 23-1 shows on-chip hardware initialization by reset action.

On-chip Hardware	Initial Value
Program counter (PC)	(FFFF _H) - (FFFE _H)
RAM page register (RPR)	0
G-flag (G)	0
Operation mode	Main-frequency clock

On-chip Hardware	Initial Value
Peripheral clock	Off
Watchdog timer	Disable
Control registers	Refer to Table 8-1
Power fail detector	Disable

Table 23-1 Initializing Internal Status by Reset Action

External Reset Input

The reset input is the $\overline{\text{RESET}}$ pin, which is the input to a Schmitt Trigger. A reset is accomplished by holding the $\overline{\text{RESET}}$ pin low for at least 8 oscillator periods, within the operating voltage range and oscillation stable, it is applied, and the internal state is initialized. After reset, 65.5ms (at 4 MHz) add with 7 oscillator periods are required to start execution as shown in Figure 23-2.

Internal RAM is not affected by reset. When V_{DD} is turned on, the RAM content is indeterminate. Therefore, this RAM should be initialized before read or tested it.

When the $\overline{\text{RESET}}$ pin input goes to high, the reset operation is released and the program execution starts at the vector address stored at addresses FFFE_H - FFFF_H.

A connection for simple power-on-reset is shown in Figure 23-1.

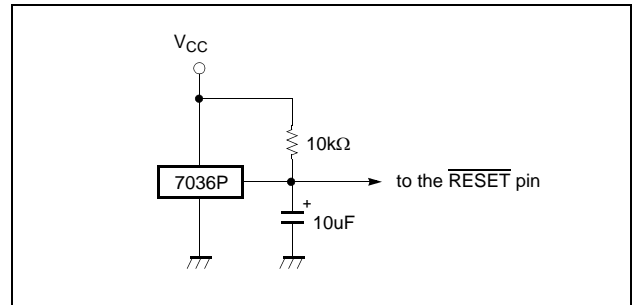

Figure 23-1 Simple Power-on-Reset Circuit

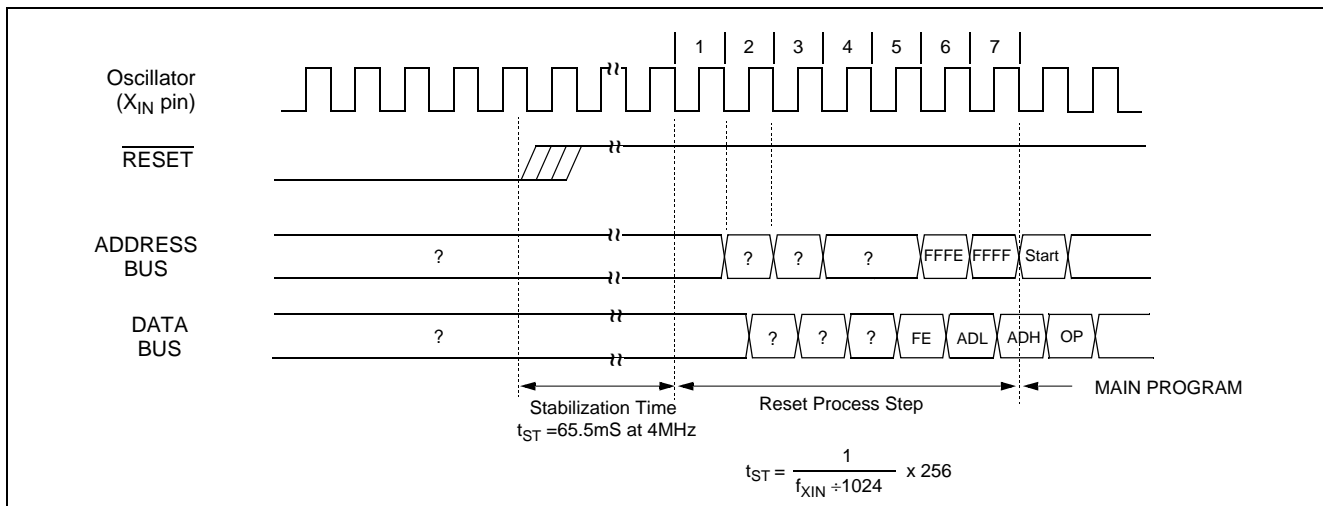

Figure 23-2 Timing Diagram after Reset

Address Fail Reset

The Address Fail Reset is the function to reset the system by checking code access of abnormal and unwished address caused by erroneous program code itself or external noise, which could

not be returned to normal operation and would become malfunction state. If the CPU tries to fetch the instruction from ineffective code area or RAM area, the address fail reset is occurred. Please refer to Figure 11-2 for setting address fail option.

24. POWER FAIL PROCESSOR

The MC80F0424/0432/0448 has an on-chip power fail detection circuitry to immunize against power noise. A configuration register, PFDR, can enable or disable the power fail detect circuitry. Whenever V_{DD} falls close to or below power fail voltage for 100ns, the power fail situation may reset or freeze MCU according to PFDM bit of PFDR. Refer to “Figure 24-1 Power Fail Voltage Detector Register” on page 111.

In the in-circuit emulator, power fail function is not implemented and user can not experiment with it. Therefore, after final development of user program, this function may be experimented or evaluated.

Note: User can select power fail voltage level according to CONFIG register(20FFH) at the FLASH MCU(MC80F0424/0432/0448) but must select the power fail voltage level to define PFD option of "Mask Order & Verification Sheet" at the mask chip(MC80C0424/0432/0448), because the power fail voltage level of mask chip is determined according to mask option.

Note: If power fail voltage is selected to 2.4V or 2.7V on below 3V operation, MCU is freezed at all the times.

Power Fail Function	OTP	MASK
Enable/Disable	PFDEN flag	PFDEN flag
Level Selection	PFS0 bit PFS1 bit	Mask option

Table 24-1 Power fail processor

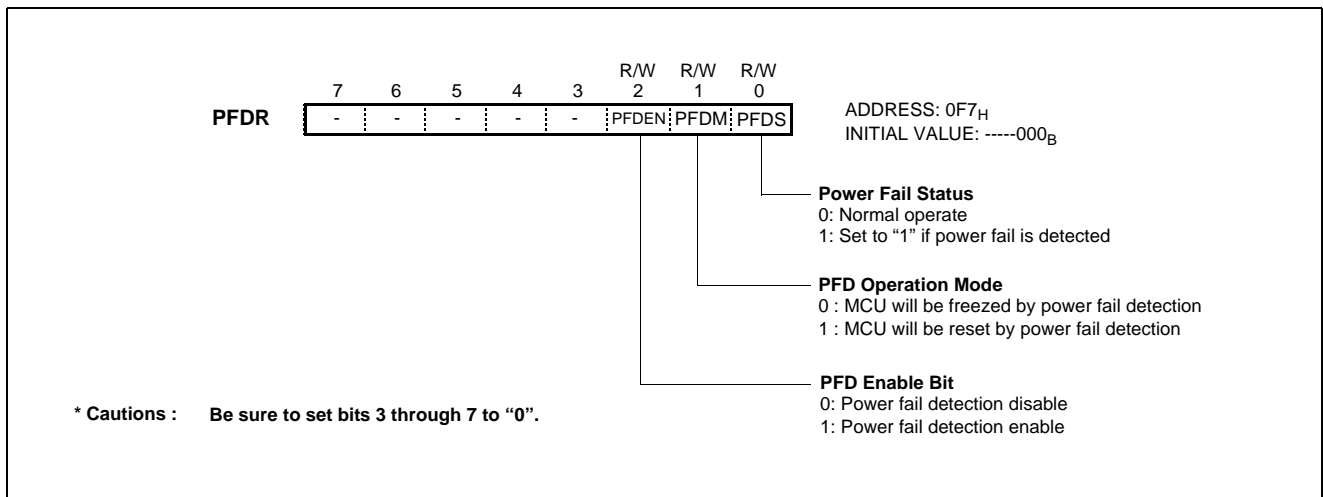

Figure 24-1 Power Fail Voltage Detector Register

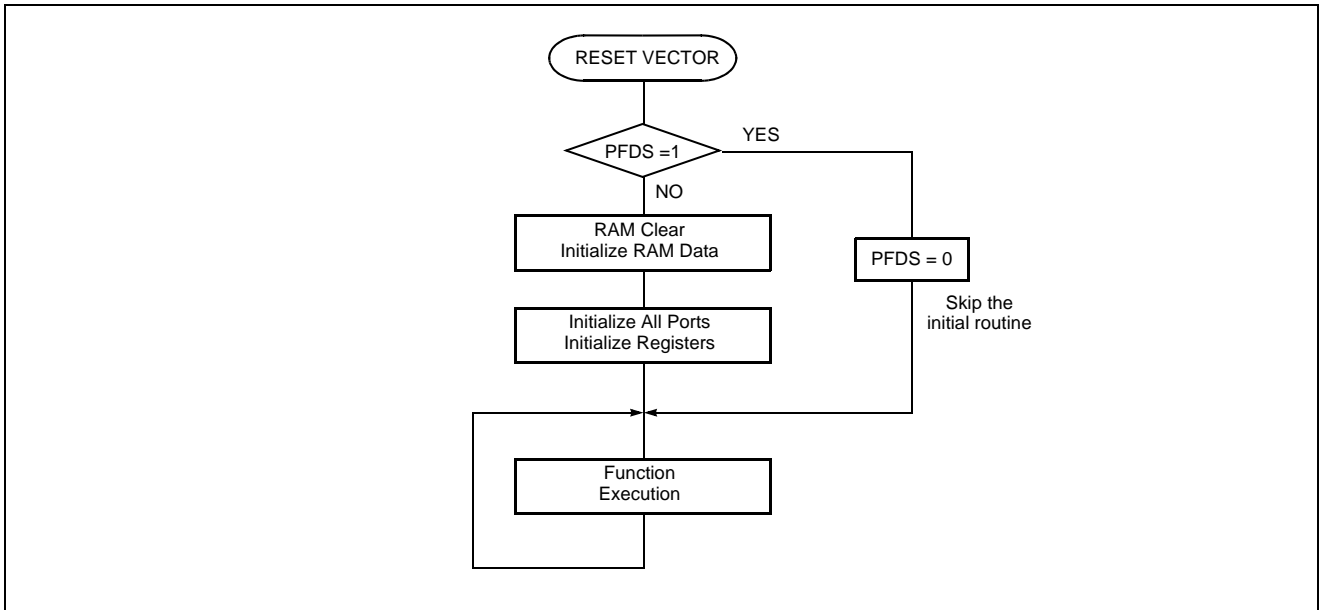

Figure 24-2 Example S/W of Reset flow by Power fail

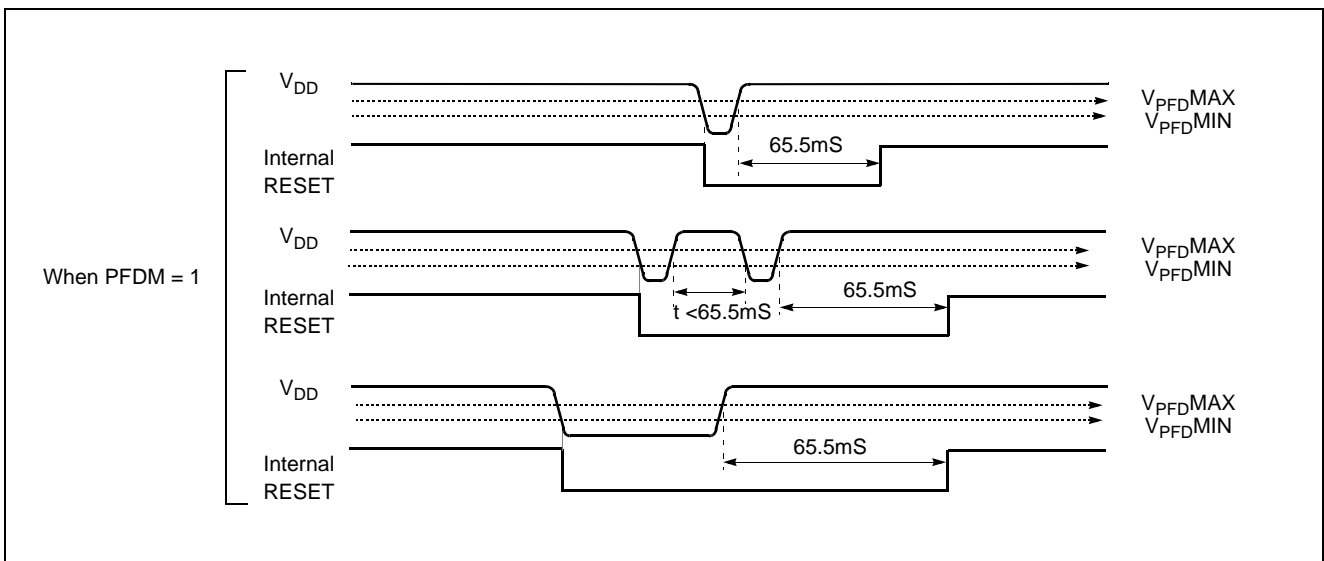

Figure 24-3 Power Fail Processor Situations (at 4MHz operation)

25. FLASH PROGRAMMING

The Device Configuration Area can be programmed or left un-programmed to select device configuration such as security bit. This area is not accessible during normal execution but is reada-

ble and writable during FLASH program / verify mode. The Device Configuration Area register is located at the address 20FFH.

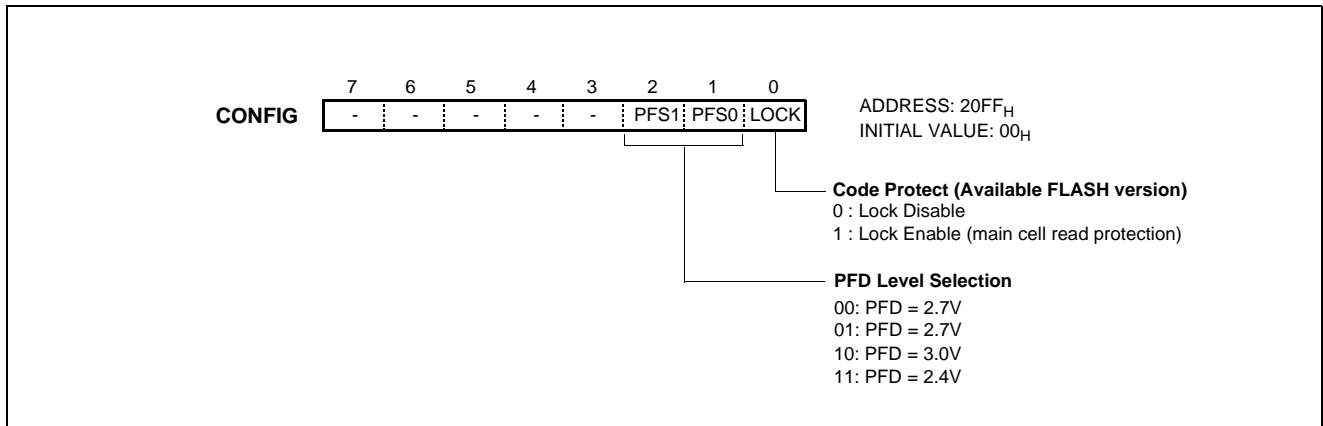

Figure 25-1 Device Configuration Area Register

25.1 Lock bit

The lock bit exists in Device Configuration Area register. If lock bit is programmed and user tries to read FLASH memory cell, the output data from the data port is 5AH that means the normal pro-

tection operation of user program data. Once the lock bit is programmed, the user can't modify and read the data of user program area.

25.2 Power Fail Detection level

The power fail detection provides 3 level of detection, 2.4V, 2.7V and 3.0V. The default level of detection is 2.7V and this level is applied if user does not select the specific level in FLASH pro-

gramming S/W tools. For more information, refer to "24. POWER FAIL PROCESSOR" on page 111

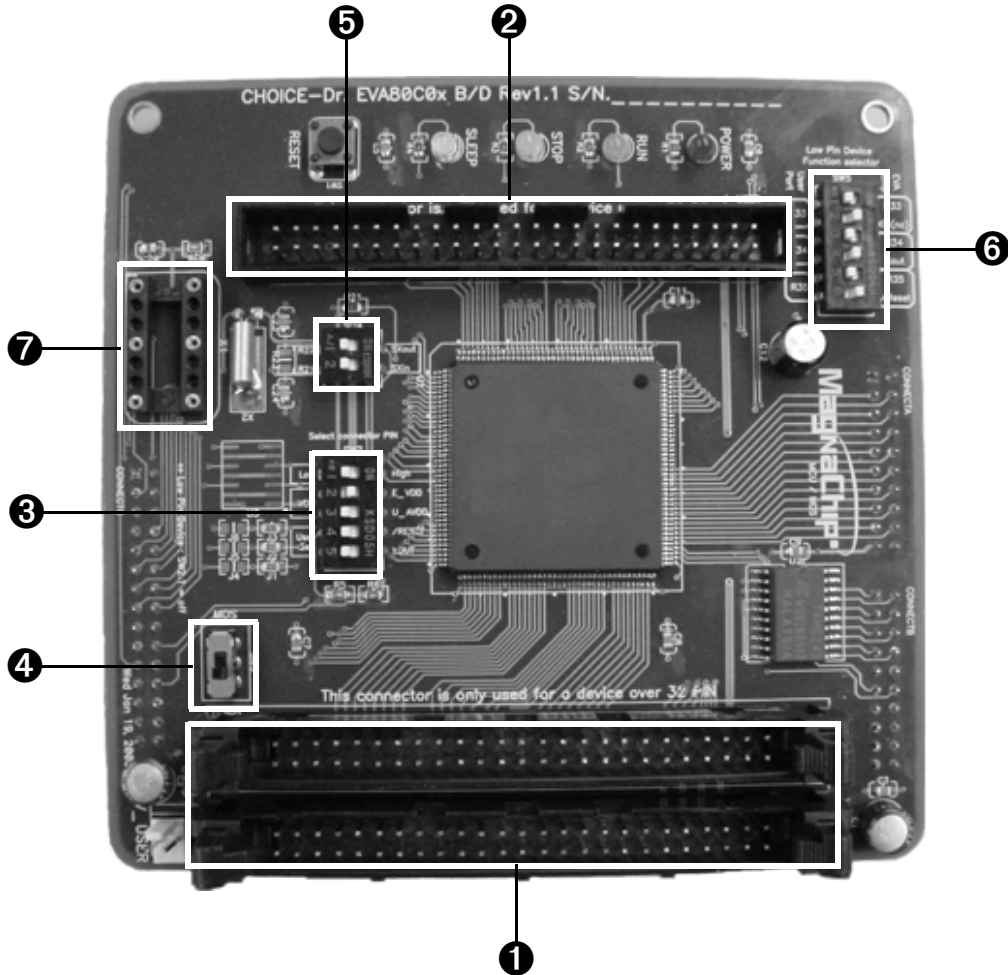

26. Emulator EVA. Board Setting



J_USERB						J_USERA					
VDD	1	<input type="checkbox"/>	<input type="checkbox"/>	<input type="checkbox"/>	<input type="checkbox"/>	VDD	1	<input type="checkbox"/>	<input type="checkbox"/>	<input type="checkbox"/>	<input type="checkbox"/>
AVDD	3	<input type="checkbox"/>	<input type="checkbox"/>	<input type="checkbox"/>	<input type="checkbox"/>	R70	3	<input type="checkbox"/>	<input type="checkbox"/>	<input type="checkbox"/>	<input type="checkbox"/>
GND	5	<input type="checkbox"/>	<input type="checkbox"/>	<input type="checkbox"/>	<input type="checkbox"/>	R72	5	<input type="checkbox"/>	<input type="checkbox"/>	<input type="checkbox"/>	<input type="checkbox"/>
R67	7	<input type="checkbox"/>	<input type="checkbox"/>	<input type="checkbox"/>	<input type="checkbox"/>	R74	7	<input type="checkbox"/>	<input type="checkbox"/>	<input type="checkbox"/>	<input type="checkbox"/>
R65	9	<input type="checkbox"/>	<input type="checkbox"/>	<input type="checkbox"/>	<input type="checkbox"/>	R76	9	<input type="checkbox"/>	<input type="checkbox"/>	<input type="checkbox"/>	<input type="checkbox"/>
R63	11	<input type="checkbox"/>	<input type="checkbox"/>	<input type="checkbox"/>	<input type="checkbox"/>	GND	11	<input type="checkbox"/>	<input type="checkbox"/>	<input type="checkbox"/>	<input type="checkbox"/>
R61	13	<input type="checkbox"/>	<input type="checkbox"/>	<input type="checkbox"/>	<input type="checkbox"/>	R80	13	<input type="checkbox"/>	<input type="checkbox"/>	<input type="checkbox"/>	<input type="checkbox"/>
GND	15	<input type="checkbox"/>	<input type="checkbox"/>	<input type="checkbox"/>	<input type="checkbox"/>	R82	15	<input type="checkbox"/>	<input type="checkbox"/>	<input type="checkbox"/>	<input type="checkbox"/>
R57	17	<input type="checkbox"/>	<input type="checkbox"/>	<input type="checkbox"/>	<input type="checkbox"/>	R84	17	<input type="checkbox"/>	<input type="checkbox"/>	<input type="checkbox"/>	<input type="checkbox"/>
R55	19	<input type="checkbox"/>	<input type="checkbox"/>	<input type="checkbox"/>	<input type="checkbox"/>	R86	19	<input type="checkbox"/>	<input type="checkbox"/>	<input type="checkbox"/>	<input type="checkbox"/>
R53	21	<input type="checkbox"/>	<input type="checkbox"/>	<input type="checkbox"/>	<input type="checkbox"/>	GND	21	<input type="checkbox"/>	<input type="checkbox"/>	<input type="checkbox"/>	<input type="checkbox"/>
R51	23	<input type="checkbox"/>	<input type="checkbox"/>	<input type="checkbox"/>	<input type="checkbox"/>	R00	23	<input type="checkbox"/>	<input type="checkbox"/>	<input type="checkbox"/>	<input type="checkbox"/>
GND	25	<input type="checkbox"/>	<input type="checkbox"/>	<input type="checkbox"/>	<input type="checkbox"/>	R02	25	<input type="checkbox"/>	<input type="checkbox"/>	<input type="checkbox"/>	<input type="checkbox"/>
R47	27	<input type="checkbox"/>	<input type="checkbox"/>	<input type="checkbox"/>	<input type="checkbox"/>	R04	27	<input type="checkbox"/>	<input type="checkbox"/>	<input type="checkbox"/>	<input type="checkbox"/>
R45	29	<input type="checkbox"/>	<input type="checkbox"/>	<input type="checkbox"/>	<input type="checkbox"/>	R06	29	<input type="checkbox"/>	<input type="checkbox"/>	<input type="checkbox"/>	<input type="checkbox"/>
R43	31	<input type="checkbox"/>	<input type="checkbox"/>	<input type="checkbox"/>	<input type="checkbox"/>	GND	31	<input type="checkbox"/>	<input type="checkbox"/>	<input type="checkbox"/>	<input type="checkbox"/>
R41	33	<input type="checkbox"/>	<input type="checkbox"/>	<input type="checkbox"/>	<input type="checkbox"/>	R10	33	<input type="checkbox"/>	<input type="checkbox"/>	<input type="checkbox"/>	<input type="checkbox"/>
GND	35	<input type="checkbox"/>	<input type="checkbox"/>	<input type="checkbox"/>	<input type="checkbox"/>	R12	35	<input type="checkbox"/>	<input type="checkbox"/>	<input type="checkbox"/>	<input type="checkbox"/>
R37	37	<input type="checkbox"/>	<input type="checkbox"/>	<input type="checkbox"/>	<input type="checkbox"/>	R14	37	<input type="checkbox"/>	<input type="checkbox"/>	<input type="checkbox"/>	<input type="checkbox"/>
R35	39	<input type="checkbox"/>	<input type="checkbox"/>	<input type="checkbox"/>	<input type="checkbox"/>	R16	39	<input type="checkbox"/>	<input type="checkbox"/>	<input type="checkbox"/>	<input type="checkbox"/>
R33	41	<input type="checkbox"/>	<input type="checkbox"/>	<input type="checkbox"/>	<input type="checkbox"/>	GND	41	<input type="checkbox"/>	<input type="checkbox"/>	<input type="checkbox"/>	<input type="checkbox"/>
R31	43	<input type="checkbox"/>	<input type="checkbox"/>	<input type="checkbox"/>	<input type="checkbox"/>	R20	43	<input type="checkbox"/>	<input type="checkbox"/>	<input type="checkbox"/>	<input type="checkbox"/>
GND	45	<input type="checkbox"/>	<input type="checkbox"/>	<input type="checkbox"/>	<input type="checkbox"/>	R22	45	<input type="checkbox"/>	<input type="checkbox"/>	<input type="checkbox"/>	<input type="checkbox"/>
U_Reset	47	<input type="checkbox"/>	<input type="checkbox"/>	<input type="checkbox"/>	<input type="checkbox"/>	R24	47	<input type="checkbox"/>	<input type="checkbox"/>	<input type="checkbox"/>	<input type="checkbox"/>
GND	49	<input type="checkbox"/>	<input type="checkbox"/>	<input type="checkbox"/>	<input type="checkbox"/>	R26	49	<input type="checkbox"/>	<input type="checkbox"/>	<input type="checkbox"/>	<input type="checkbox"/>

DIP Switch and VR Setting

Before executing the user program, set up the EVA board according to the below configuration.

DIP S/W	Description	ON/OFF Setting
①	- This connector is only used for a device over 32 PIN.	Used for the MC80F0424/0432/0448.
②	- This connector is only used for a device under 32 PIN.	Not used for the MC80F0424/0432/0448.
③ SW2	1  ON Eva. select switch	Must be ON position. ON : MC80F0424/0432/0448 selection OFF : other MCU selection
	2 3  Use Eva. V _{DD} Use User's AV _{DD} AV _{DD} pin select switch	These switches select the AV _{DD} source. ON & OFF : Use Eva. V _{DD} OFF & ON : Use User AV _{DD}
	4 This switch select the /Reset source.	Normally OFF . EVA. chip can be reset by external user target board. ON : Reset is available by either user target system board or Emulator RESET switch. OFF : Reset the MCU by Emulator RESET switch. Does not work from user target board.
	5 This switch select the X _{OUT} signal on/off.	Normally OFF . MCU X _{OUT} pin is disconnected internally in the Emulator. Some circumstance user may connect this circuit. ON : Output X _{OUT} signal OFF : Disconnect circuit
④ SW3	1  Use MDS Power Use User's Power This switch select Eva. B/D Power supply source.	Normally MDS . This switch select Eva. B/D Power supply source.
⑤ SW4	1 This switch select the R22 or SX _{OUT} . 2 This switch select the R21 or SX _{IN} .	These switches select the Normal I/O port(off) or Sub-Clock (on). ON : SX _{OUT} , SX _{IN} selection OFF : R22, R21 selection

DIP S/W		Description	ON/OFF Setting
⑥ SW5	1 2	These switches select the R33 or X _{IN}	This switch select the Normal I/O port(on&off) or special function select(off&on). It is not used for the MC80F0424/0432/0448.
	3 4	These switches select the R34 or X _{OUT}	
	5 6	These switches select the R35 or /Reset	
⑦	-	This is External oscillation socket(CAN Type. OSC)	This is for External Clock(CAN Type. OSC).

27. IN-SYSTEM PROGRAMMING (ISP)

27.1 Getting Started / Installation

The following section details the procedure for accomplishing the installation procedure.

1. Connect the serial(RS-232C) cable between a target board and the COM port of your PC.
2. Configure the COM port of your PC as following.
3. Turn your target B/D power switch ON. Your target B/D must be configured to enter the ISP mode.
4. Run the MagnaChip ISP software.
5. Press the Reset Button in the ISP S/W. If the status windows shows a message as "Connected", all the conditions for ISP are provided.

Baudrate	115,200
Data bit	8
Parity	No
Stop bit	1
Flow control	No

27.2 Basic ISP S/W Information

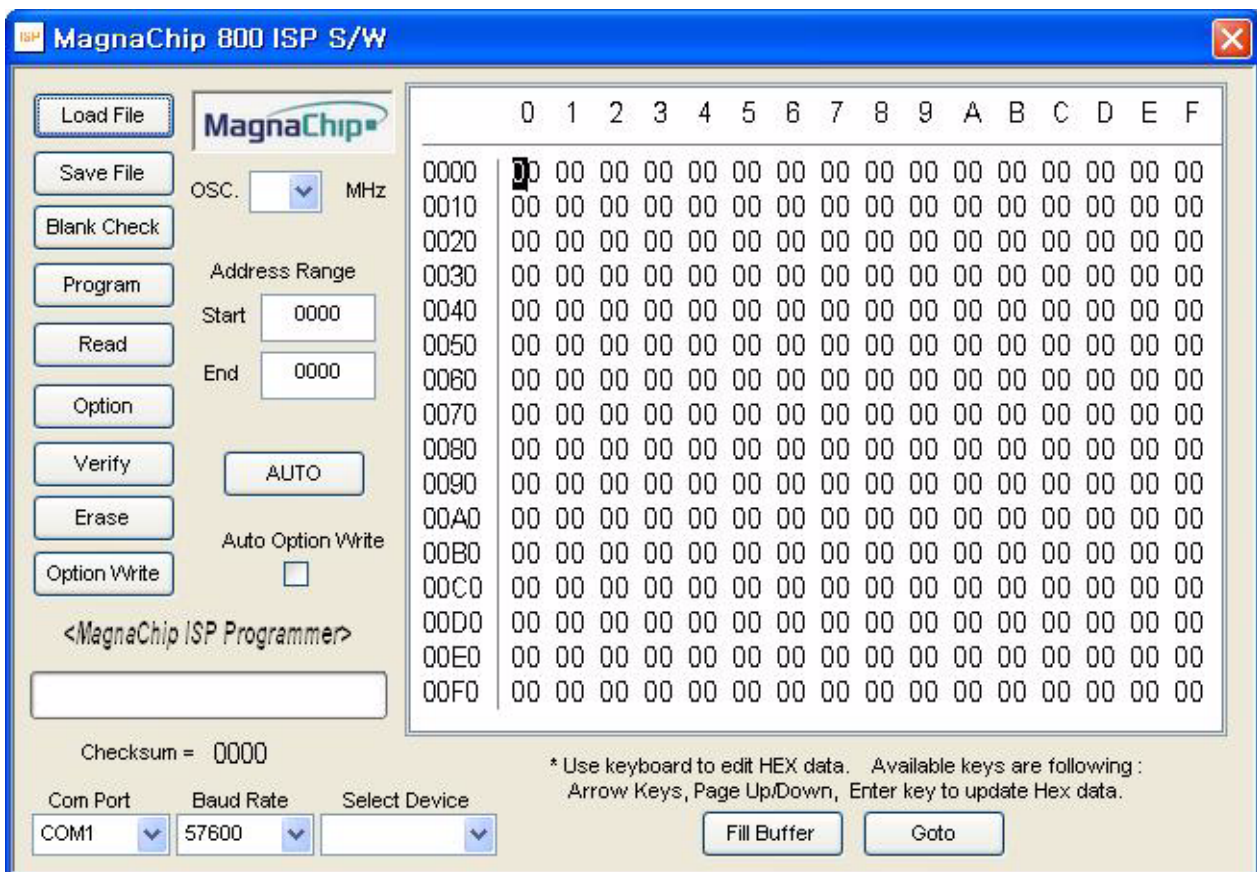

Function	Description
Load HEX File	Load the data from the selected file storage into the memory buffer.
Save HEX File	Save the current data in your memory buffer to a disk storage by using the Intel Motorola HEX format.
Erase	Erase the data in your target MCU before programming it.
Blank Check	Verify whether or not a device is in an erased or unprogrammed state.
Program	This button enables you to place new data from the memory buffer into the target device.
Read	Read the data in the target MCU into the buffer for examination. The checksum will be displayed on the checksum box.
Verify	Assures that data in the device matches data in the memory buffer. If your device is secured, a verification error is detected.
Option Write	Program the configuration data of target MCU. The security locking is performed with this button.
Option	Set the configuration data of target MCU. The security locking is set with this button.
AUTO	Erase & Program & Verify.
Auto Option Write	If selected with check mark, the option write is performed after erasure and write.
Edit Buffer	Modify the data in the selected address in your buffer memory
Fill Buffer	Fill the selected area with a data.
Goto	Display the selected page.
OSC. _____ MHz	Enter your target system's oscillator value with discarding below point.
Start _____	Starting address
End _____	End address
Checksum	Display the checksum(Hexdecimal) after reading the target device.
Com Port	Select serial port.
Baud Rate	Select UART baud rate.
Select Device	Select target device.
Page Up Key	Display the previous page of your memory buffer.
Page Down Key	Display the higher page than the current location.

Table 27-1 ISP Function Description

27.3 Hardware Conditions to Enter the ISP Mode

The In-System Programming (ISP) is performed without removing the microcontroller from the target system. The In-System Programming (ISP) facility consists of a series of internal hardware resources coupled with internal firmware through the serial port. The In-System Programming (ISP) facility has made in-circuit programming in an embedded application possible with a

minimum of additional expense in components and circuit board area. The boot loader can be executed by holding ALEB high, RST/V_{PP} as +9V, and ACLK0 with the OSC. 1.8432MHz. The ISP function uses five pins: TxD0, RxD0, ALEB, ACLK0 and RST/V_{PP}.

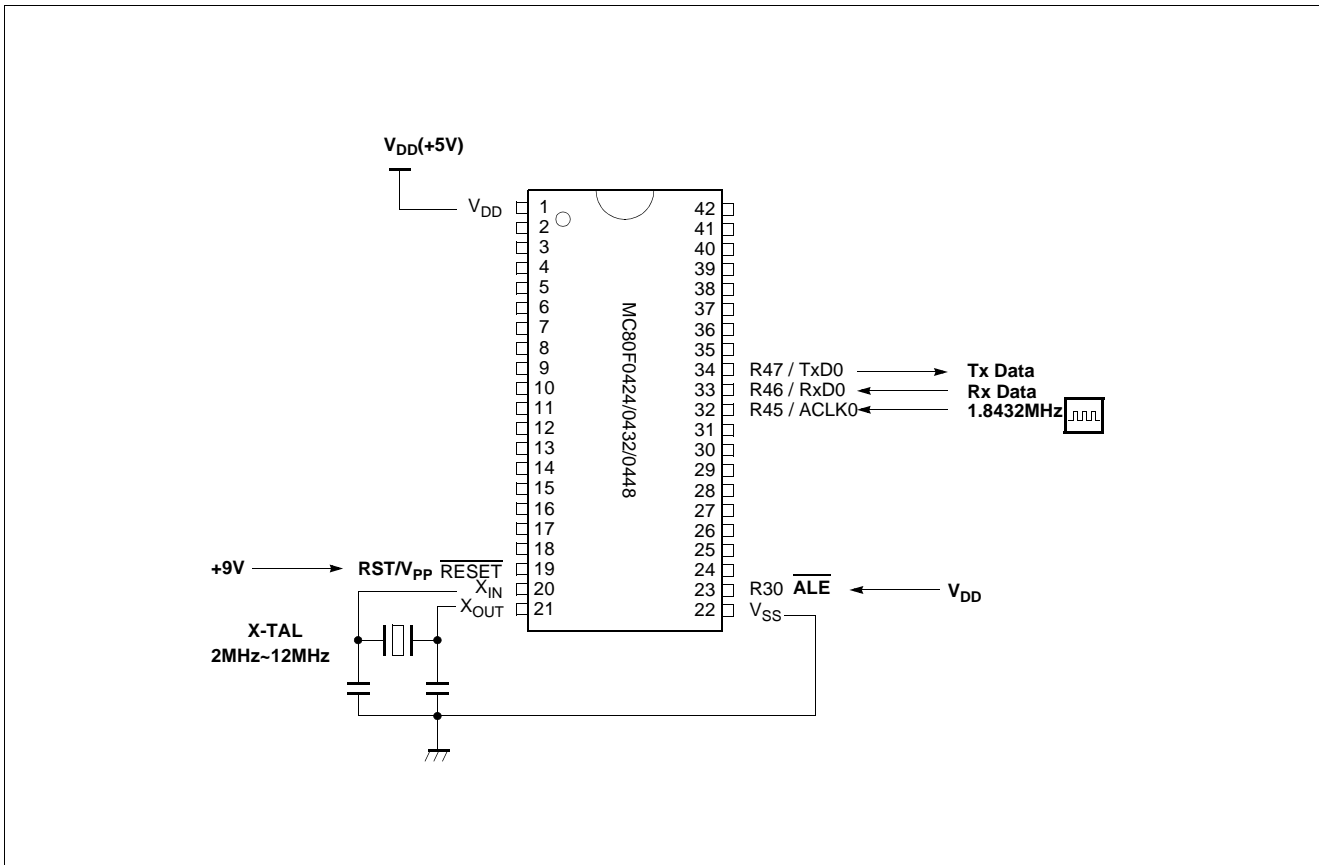

Figure 27-1 ISP Configuration

Note: Considerations to implement ISP function in a user target board

- The ACLK0 must be connected to the specified oscillator.
- Connect the +9V to $\overline{\text{RESET}}/\text{V}_{\text{PP}}$ pin directly.
- The ALEB pin must be pulled high.
- The main clk must be higher than 2MHz.

27.4 Reference ISP Circuit Diagram and MagnaChip Supplied ISP Board

The ISP software and hardware circuit diagram are provided at www.magnachipmcu.com. To get a ISP B/D, contact to sales department. The following circuit diagram is for reference use..

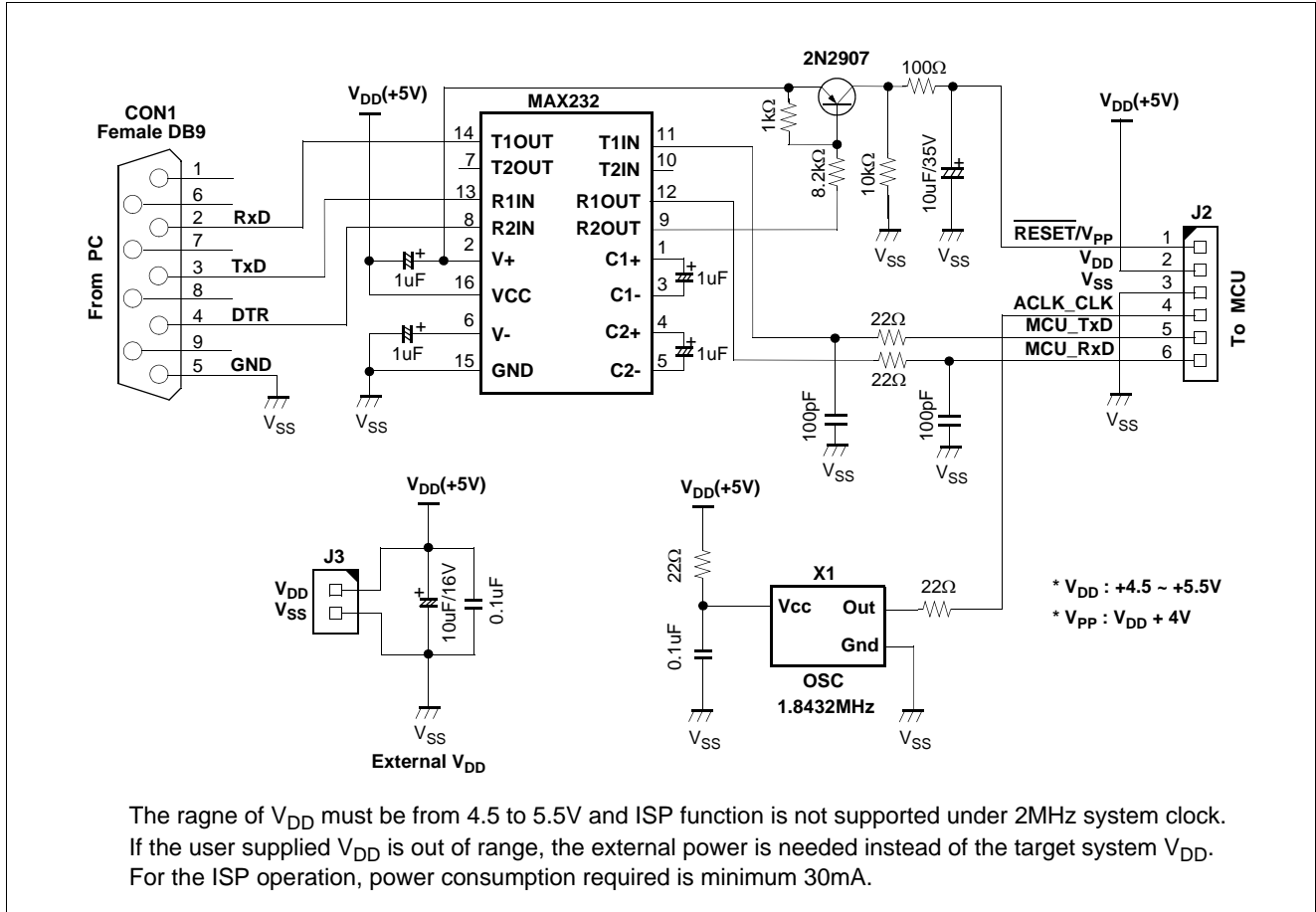

The range of V_{DD} must be from 4.5 to 5.5V and ISP function is not supported under 2MHz system clock. If the user supplied V_{DD} is out of range, the external power is needed instead of the target system V_{DD}. For the ISP operation, power consumption required is minimum 30mA.

Figure 27-2 Reference ISP Circuit Diagram

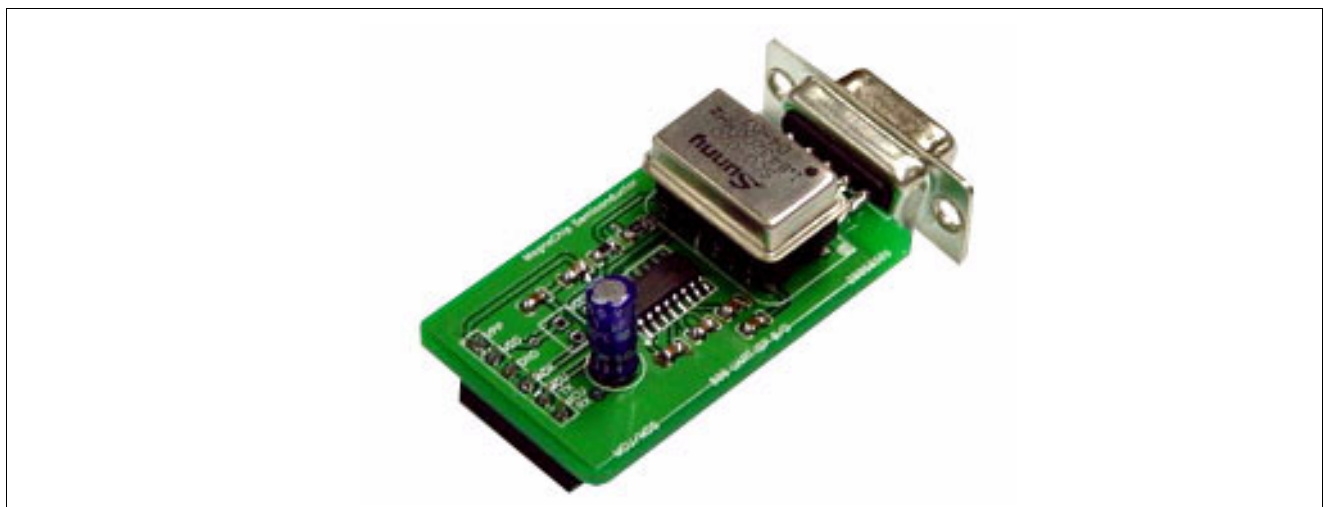

Figure 27-3 MagnaChip supplied ISP Board

APPENDIX

A. INSTRUCTION MAP

LOW HIGH	0000 00	00001 01	00010 02	00011 03	00100 04	00101 05	00110 06	00111 07	01000 08	01001 09	01010 0A	01011 0B	01100 0C	01101 0D	01110 0E	01111 0F
000	-	SET1 dp.bit	BBS A.bit,rel	BBS dp.bit,rel	ADC #imm	ADC dp	ADC dp+X	ADC !abs	ASL A	ASL dp	TCALL 0	SETA1 .bit	BIT dp	POP A	PUSH A	BRK
001	CLRC	"	"	"	SBC #imm	SBC dp	SBC dp+X	SBC !abs	ROL A	ROL dp	TCALL 2	CLRA1 .bit	COM dp	POP X	PUSH X	BRA rel
010	CLRG	"	"	"	CMP #imm	CMP dp	CMP dp+X	CMP !abs	LSR A	LSR dp	TCALL 4	NOT1 M.bit	TST dp	POP Y	PUSH Y	PCALL Upage
011	DI	"	"	"	OR #imm	OR dp	OR dp+X	OR !abs	ROR A	ROR dp	TCALL 6	OR1 OR1B	CMPX dp	POP PSW	PUSH PSW	RET
100	CLRV	"	"	"	AND #imm	AND dp	AND dp+X	AND !abs	INC A	INC dp	TCALL 8	AND1 AND1B	CMPY dp	CBNE dp+X	TXSP	INC X
101	SETC	"	"	"	EOR #imm	EOR dp	EOR dp+X	EOR !abs	DEC A	DEC dp	TCALL 10	EOR1 EOR1B	DBNE dp	XMA dp+X	TSPX	DEC X
110	SETG	"	"	"	LDA #imm	LDA dp	LDA dp+X	LDA !abs	TXA	LDY dp	TCALL 12	LDC LDCB	LDX dp	LDX dp+Y	XCN	DAS
111	EI	"	"	"	LDM dp,#imm	STA dp	STA dp+X	STA !abs	TAX	STY dp	TCALL 14	STC M.bit	STX dp	STX dp+Y	XAX	STOP

LOW HIGH	10000 10	10001 11	10010 12	10011 13	10100 14	10101 15	10110 16	10111 17	11000 18	11001 19	11010 1A	11011 1B	11100 1C	11101 1D	11110 1E	11111 1F
000	BPL rel	CLR1 dp.bit	BBC A.bit,rel	BBC dp.bit,rel	ADC {X}	ADC !abs+Y	ADC [dp+X]	ADC [dp]+Y	ASL !abs	ASL dp+X	TCALL 1	JMP !abs	BIT !abs	ADDW dp	LDX #imm	JMP [!abs]
001	BVC rel	"	"	"	SBC {X}	SBC !abs+Y	SBC [dp+X]	SBC [dp]+Y	ROL !abs	ROL dp+X	TCALL 3	CALL !abs	TEST !abs	SUBW dp	LDY #imm	JMP [dp]
010	BCC rel	"	"	"	CMP {X}	CMP !abs+Y	CMP [dp+X]	CMP [dp]+Y	LSR !abs	LSR dp+X	TCALL 5	MUL	TCLR1 !abs	CMPW dp	CMPX #imm	CALL [dp]
011	BNE rel	"	"	"	OR {X}	OR !abs+Y	OR [dp+X]	OR [dp]+Y	ROR !abs	ROR dp+X	TCALL 7	DBNE Y	CMPX !abs	LDYA dp	CMPY #imm	RETI
100	BMI rel	"	"	"	AND {X}	AND !abs+Y	AND [dp+X]	AND [dp]+Y	INC !abs	INC dp+X	TCALL 9	DIV	CMPY !abs	INCW dp	INC Y	TAY
101	BVS rel	"	"	"	EOR {X}	EOR !abs+Y	EOR [dp+X]	EOR [dp]+Y	DEC !abs	DEC dp+X	TCALL 11	XMA {X}	XMA dp	DECW dp	DEC Y	TYA
110	BCS rel	"	"	"	LDA {X}	LDA !abs+Y	LDA [dp+X]	LDA [dp]+Y	LDY !abs	LDY dp+X	TCALL 13	LDA {X}+	LDX !abs	STYA dp	XAY	DAA
111	BEQ rel	"	"	"	STA {X}	STA !abs+Y	STA [dp+X]	STA [dp]+Y	STY !abs	STY dp+X	TCALL 15	STA {X}+	STX !abs	CBNE dp	XYX	NOP

B. INSTRUCTION SET

1. ARITHMETIC/ LOGIC OPERATION

NO.	MNEMONIC	OP CODE	BYTE NO	CYCLE NO	OPERATION	FLAG NVGBHIZC
1	ADC #imm	04	2	2	Add with carry. $A \leftarrow (A) + (M) + C$	NV--H-ZC
2	ADC dp	05	2	3		
3	ADC dp + X	06	2	4		
4	ADC !abs	07	3	4		
5	ADC !abs + Y	15	3	5		
6	ADC [dp + X]	16	2	6		
7	ADC [dp] + Y	17	2	6		
8	ADC { X }	14	1	3		
9	AND #imm	84	2	2	Logical AND $A \leftarrow (A) \wedge (M)$	N-----Z-
10	AND dp	85	2	3		
11	AND dp + X	86	2	4		
12	AND !abs	87	3	4		
13	AND !abs + Y	95	3	5		
14	AND [dp + X]	96	2	6		
15	AND [dp] + Y	97	2	6		
16	AND { X }	94	1	3		
17	ASL A	08	1	2	A	N-----ZC
18	ASL dp	09	2	4		
19	ASL dp + X	19	2	5		
20	ASL !abs	18	3	5		
21	CMP #imm	44	2	2	Compare accumulator contents with memory contents $(A) - (M)$	N-----ZC
22	CMP dp	45	2	3		
23	CMP dp + X	46	2	4		
24	CMP !abs	47	3	4		
25	CMP !abs + Y	55	3	5		
26	CMP [dp + X]	56	2	6		
27	CMP [dp] + Y	57	2	6		
28	CMP { X }	54	1	3		
29	CMPX #imm	5E	2	2	Compare X contents with memory contents $(X) - (M)$	N-----ZC
30	CMPX dp	6C	2	3		
31	CMPX !abs	7C	3	4		
32	CMPY #imm	7E	2	2	Compare Y contents with memory contents $(Y) - (M)$	N-----ZC
33	CMPY dp	8C	2	3		
34	CMPY !abs	9C	3	4		
35	COM dp	2C	2	4	1'S Complement : $(dp) \leftarrow \sim(dp)$	N-----Z-
36	DAA	DF	1	3	Decimal adjust for addition	N-----ZC
37	DAS	CF	1	3	Decimal adjust for subtraction	N-----ZC
38	DEC A	A8	1	2	Decrement $M \leftarrow (M) - 1$	N-----Z-
39	DEC dp	A9	2	4		
40	DEC dp + X	B9	2	5		
41	DEC !abs	B8	3	5		
42	DEC X	AF	1	2		
43	DEC Y	BE	1	2		
44	DIV	9B	1	12		

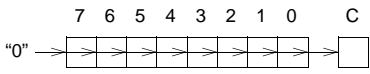
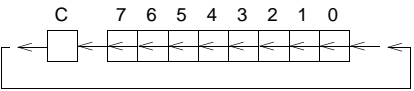
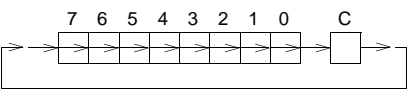
NO.	MNEMONIC	OP CODE	BYTE NO	CYCLE NO	OPERATION	FLAG NVGBHIZC
45	EOR #imm	A4	2	2	Exclusive OR $A \leftarrow (A) \oplus (M)$	N-----Z-
46	EOR dp	A5	2	3		
47	EOR dp + X	A6	2	4		
48	EOR !abs	A7	3	4		
49	EOR !abs + Y	B5	3	5		
50	EOR [dp + X]	B6	2	6		
51	EOR [dp] + Y	B7	2	6		
52	EOR { X }	B4	1	3		
53	INC A	88	1	2	Increment $M \leftarrow (M) + 1$	N-----ZC
54	INC dp	89	2	4		
55	INC dp + X	99	2	5		
56	INC !abs	98	3	5		
57	INC X	8F	1	2		
58	INC Y	9E	1	2		
59	LSR A	48	1	2	Logical shift right 	N-----ZC
60	LSR dp	49	2	4		
61	LSR dp + X	59	2	5		
62	LSR !abs	58	3	5		
63	MUL	5B	1	9	Multiply : $YA \leftarrow Y \times A$	N-----Z-
64	OR #imm	64	2	2	Logical OR $A \leftarrow (A) \vee (M)$	N-----Z-
65	OR dp	65	2	3		
66	OR dp + X	66	2	4		
67	OR !abs	67	3	4		
68	OR !abs + Y	75	3	5		
69	OR [dp + X]	76	2	6		
70	OR [dp] + Y	77	2	6		
71	OR { X }	74	1	3		
72	ROL A	28	1	2	Rotate left through carry 	N-----ZC
73	ROL dp	29	2	4		
74	ROL dp + X	39	2	5		
75	ROL !abs	38	3	5		
76	ROR A	68	1	2	Rotate right through carry 	N-----ZC
77	ROR dp	69	2	4		
78	ROR dp + X	79	2	5		
79	ROR !abs	78	3	5		
80	SBC #imm	24	2	2	Subtract with carry $A \leftarrow (A) - (M) - \sim(C)$	NV--HZC
81	SBC dp	25	2	3		
82	SBC dp + X	26	2	4		
83	SBC !abs	27	3	4		
84	SBC !abs + Y	35	3	5		
85	SBC [dp + X]	36	2	6		
86	SBC [dp] + Y	37	2	6		
87	SBC { X }	34	1	3		
88	TST dp	4C	2	3	Test memory contents for negative or zero (dp) - 00 _H	N-----Z-
89	XCN	CE	1	5	Exchange nibbles within the accumulator $A_7 \sim A_4 \leftrightarrow A_3 \sim A_0$	N-----Z-

2. REGISTER / MEMORY OPERATION

NO.	MNEMONIC	OP CODE	BYTE NO	CYCLE NO	OPERATION	FLAG NVGBHIZC
1	LDA #imm	C4	2	2	Load accumulator	N-----Z-
2	LDA dp	C5	2	3	$A \leftarrow (M)$	
3	LDA dp + X	C6	2	4		
4	LDA !abs	C7	3	4		
5	LDA !abs + Y	D5	3	5		
6	LDA [dp + X]	D6	2	6		
7	LDA [dp] + Y	D7	2	6		
8	LDA { X }	D4	1	3		
9	LDA { X }+	DB	1	4	X- register auto-increment : $A \leftarrow (M)$, $X \leftarrow X + 1$	
10	LDM dp,#imm	E4	3	5	Load memory with immediate data : $(M) \leftarrow \text{imm}$	-----
11	LDX #imm	1E	2	2	Load X-register	N-----Z-
12	LDX dp	CC	2	3	$X \leftarrow (M)$	
13	LDX dp + Y	CD	2	4		
14	LDX !abs	DC	3	4		
15	LDY #imm	3E	2	2	Load Y-register	N-----Z-
16	LDY dp	C9	2	3	$Y \leftarrow (M)$	
17	LDY dp + X	D9	2	4		
18	LDY !abs	D8	3	4		
19	STA dp	E5	2	4	Store accumulator contents in memory	-----
20	STA dp + X	E6	2	5	$(M) \leftarrow A$	
21	STA !abs	E7	3	5		
22	STA !abs + Y	F5	3	6		
23	STA [dp + X]	F6	2	7		
24	STA [dp] + Y	F7	2	7		
25	STA { X }	F4	1	4		
26	STA { X }+	FB	1	4	X- register auto-increment : $(M) \leftarrow A$, $X \leftarrow X + 1$	
27	STX dp	EC	2	4	Store X-register contents in memory	
28	STX dp + Y	ED	2	5	$(M) \leftarrow X$	
29	STX !abs	FC	3	5		
30	STY dp	E9	2	4	Store Y-register contents in memory	-----
31	STY dp + X	F9	2	5	$(M) \leftarrow Y$	
32	STY !abs	F8	3	5		
33	TAX	E8	1	2	Transfer accumulator contents to X-register : $X \leftarrow A$	N-----Z-
34	TAY	9F	1	2	Transfer accumulator contents to Y-register : $Y \leftarrow A$	N-----Z-
35	TSPX	AE	1	2	Transfer stack-pointer contents to X-register : $X \leftarrow \text{sp}$	N-----Z-
36	TXA	C8	1	2	Transfer X-register contents to accumulator: $A \leftarrow X$	N-----Z-
37	TXSP	8E	1	2	Transfer X-register contents to stack-pointer: $\text{sp} \leftarrow X$	N-----Z-
38	TYA	BF	1	2	Transfer Y-register contents to accumulator: $A \leftarrow Y$	N-----Z-
39	XAX	EE	1	4	Exchange X-register contents with accumulator : $X \leftrightarrow A$	-----
40	XAY	DE	1	4	Exchange Y-register contents with accumulator : $Y \leftrightarrow A$	-----
41	XMA dp	BC	2	5	Exchange memory contents with accumulator	N-----Z-
42	XMA dp+X	AD	2	6	$(M) \leftrightarrow A$	
43	XMA {X}	BB	1	5		
44	XYX	FE	1	4	Exchange X-register contents with Y-register : $X \leftrightarrow Y$	-----

3. 16-BIT OPERATION

NO.	MNEMONIC	OP CODE	BYTE NO	CYCLE NO	OPERATION	FLAG NVGBHIZC
1	ADDW dp	1D	2	5	16-Bits add without carry $YA \leftarrow (YA) + (dp + 1)(dp)$	NV--H-ZC
2	CMPW dp	5D	2	4	Compare YA contents with memory pair contents : $(YA) - (dp+1)(dp)$	N-----ZC
3	DECW dp	BD	2	6	Decrement memory pair $(dp+1)(dp) \leftarrow (dp+1)(dp) - 1$	N-----Z-
4	INCW dp	9D	2	6	Increment memory pair $(dp+1)(dp) \leftarrow (dp+1)(dp) + 1$	N-----Z-
5	LDYA dp	7D	2	5	Load YA $YA \leftarrow (dp + 1)(dp)$	N-----Z-
6	STYA dp	DD	2	5	Store YA $(dp + 1)(dp) \leftarrow YA$	-----
7	SUBW dp	3D	2	5	16-Bits subtract without carry $YA \leftarrow (YA) - (dp + 1)(dp)$	NV--H-ZC

4. BIT MANIPULATION

NO.	MNEMONIC	OP CODE	BYTE NO	CYCLE NO	OPERATION	FLAG NVGBHIZC
1	AND1 M.bit	8B	3	4	Bit AND C-flag : $C \leftarrow (C) \wedge (M.bit)$	-----C
2	AND1B M.bit	8B	3	4	Bit AND C-flag and NOT : $C \leftarrow (C) \wedge \sim(M.bit)$	-----C
3	BIT dp	0C	2	4	Bit test A with memory :	MM----Z-
4	BIT !abs	1C	3	5	$Z \leftarrow (A) \wedge (M), N \leftarrow (M_7), V \leftarrow (M_6)$	
5	CLR1 dp.bit	y1	2	4	Clear bit : $(M.bit) \leftarrow "0"$	-----
6	CLRA1 A.bit	2B	2	2	Clear A bit : $(A.bit) \leftarrow "0"$	-----
7	CLRC	20	1	2	Clear C-flag : $C \leftarrow "0"$	-----0
8	CLRG	40	1	2	Clear G-flag : $G \leftarrow "0"$	--0-----
9	CLRV	80	1	2	Clear V-flag : $V \leftarrow "0"$	-0--0---
10	EOR1 M.bit	AB	3	5	Bit exclusive-OR C-flag : $C \leftarrow (C) \oplus (M.bit)$	-----C
11	EOR1B M.bit	AB	3	5	Bit exclusive-OR C-flag and NOT : $C \leftarrow (C) \oplus \sim(M.bit)$	-----C
12	LDC M.bit	CB	3	4	Load C-flag : $C \leftarrow (M.bit)$	-----C
13	LDCB M.bit	CB	3	4	Load C-flag with NOT : $C \leftarrow \sim(M.bit)$	-----C
14	NOT1 M.bit	4B	3	5	Bit complement : $(M.bit) \leftarrow \sim(M.bit)$	-----
15	OR1 M.bit	6B	3	5	Bit OR C-flag : $C \leftarrow (C) \vee (M.bit)$	-----C
16	OR1B M.bit	6B	3	5	Bit OR C-flag and NOT : $C \leftarrow (C) \vee \sim(M.bit)$	-----C
17	SET1 dp.bit	x1	2	4	Set bit : $(M.bit) \leftarrow "1"$	-----
18	SETA1 A.bit	0B	2	2	Set A bit : $(A.bit) \leftarrow "1"$	-----
19	SETC	A0	1	2	Set C-flag : $C \leftarrow "1"$	-----1
20	SETG	C0	1	2	Set G-flag : $G \leftarrow "1"$	--1-----
21	STC M.bit	EB	3	6	Store C-flag : $(M.bit) \leftarrow C$	-----
22	TCLR1 !abs	5C	3	6	Test and clear bits with A : $A - (M), (M) \leftarrow (M) \wedge \sim(A)$	N-----Z-
23	TSET1 !abs	3C	3	6	Test and set bits with A : $A - (M), (M) \leftarrow (M) \vee (A)$	N-----Z-

5. BRANCH / JUMP OPERATION

NO.	MNEMONIC	OP CODE	BYTE NO	CYCLE NO	OPERATION	FLAG NVGBHIZC
1	BBC A.bit,rel	y2	2	4/6	Branch if bit clear :	-----
2	BBC dp.bit,rel	y3	3	5/7	if (bit) = 0 , then pc ← (pc) + rel	
3	BBS A.bit,rel	x2	2	4/6	Branch if bit set :	-----
4	BBS dp.bit,rel	x3	3	5/7	if (bit) = 1 , then pc ← (pc) + rel	
5	BCC rel	50	2	2/4	Branch if carry bit clear if (C) = 0 , then pc ← (pc) + rel	-----
6	BCS rel	D0	2	2/4	Branch if carry bit set if (C) = 1 , then pc ← (pc) + rel	-----
7	BEQ rel	F0	2	2/4	Branch if equal if (Z) = 1 , then pc ← (pc) + rel	-----
8	BMI rel	90	2	2/4	Branch if minus if (N) = 1 , then pc ← (pc) + rel	-----
9	BNE rel	70	2	2/4	Branch if not equal if (Z) = 0 , then pc ← (pc) + rel	-----
10	BPL rel	10	2	2/4	Branch if minus if (N) = 0 , then pc ← (pc) + rel	-----
11	BRA rel	2F	2	4	Branch always pc ← (pc) + rel	-----
12	BVC rel	30	2	2/4	Branch if overflow bit clear if (V) = 0 , then pc ← (pc) + rel	-----
13	BVS rel	B0	2	2/4	Branch if overflow bit set if (V) = 1 , then pc ← (pc) + rel	-----
14	CALL !abs	3B	3	8	Subroutine call	
15	CALL [dp]	5F	2	8	M(sp) ← (pc _H) , sp ← sp - 1 , M(sp) ← (pc _L) , sp ← sp - 1 , if !abs, pc ← abs ; if [dp], pc _L ← (dp) , pc _H ← (dp+1) .	-----
16	CBNE dp,rel	FD	3	5/7	Compare and branch if not equal :	-----
17	CBNE dp+X,rel	8D	3	6/8	if (A) ≠ (M) , then pc ← (pc) + rel.	
18	DBNE dp,rel	AC	3	5/7	Decrement and branch if not equal :	-----
19	DBNE Y,rel	7B	2	4/6	if (M) ≠ 0 , then pc ← (pc) + rel.	
20	JMP !abs	1B	3	3	Unconditional jump	
21	JMP [!abs]	1F	3	5	pc ← jump address	-----
22	JMP [dp]	3F	2	4		
23	PCALL upage	4F	2	6	U-page call M(sp) ← (pc _H) , sp ← sp - 1 , M(sp) ← (pc _L) , sp ← sp - 1 , pc _L ← (upage) , pc _H ← "OFFH" .	-----
24	TCALL n	nA	1	8	Table call : (sp) ← (pc _H) , sp ← sp - 1 , M(sp) ← (pc _L) , sp ← sp - 1 , pc _L ← (Table vector L) , pc _H ← (Table vector H)	-----

6. CONTROL OPERATION & etc.

NO.	MNEMONIC	OP CODE	BYTE NO	CYCLE NO	OPERATION	FLAG NVGBHIZC
1	BRK	0F	1	8	Software interrupt : B ← "1", M(sp) ← (pc _H), sp ← sp-1, M(s) ← (pc _L), sp ← sp - 1, M(sp) ← (PSW), sp ← sp - 1, pc _L ← (0FFDE _H), pc _H ← (0FFDF _H) .	---1-0--
2	DI	60	1	3	Disable interrupts : I ← "0"	-----0--
3	EI	E0	1	3	Enable interrupts : I ← "1"	-----1--
4	NOP	FF	1	2	No operation	-----
5	POP A	0D	1	4	sp ← sp + 1, A ← M(sp)	-----
6	POP X	2D	1	4	sp ← sp + 1, X ← M(sp)	
7	POP Y	4D	1	4	sp ← sp + 1, Y ← M(sp)	
8	POP PSW	6D	1	4	sp ← sp + 1, PSW ← M(sp)	restored
9	PUSH A	0E	1	4	M(sp) ← A , sp ← sp - 1	-----
10	PUSH X	2E	1	4	M(sp) ← X , sp ← sp - 1	
11	PUSH Y	4E	1	4	M(sp) ← Y , sp ← sp - 1	
12	PUSH PSW	6E	1	4	M(sp) ← PSW , sp ← sp - 1	
13	RET	6F	1	5	Return from subroutine sp ← sp + 1, pc _L ← M(sp), sp ← sp + 1, pc _H ← M(sp)	-----
14	RETI	7F	1	6	Return from interrupt sp ← sp + 1, PSW ← M(sp), sp ← sp + 1, pc _L ← M(sp), sp ← sp + 1, pc _H ← M(sp)	restored
15	STOP	EF	1	3	Stop mode (halt CPU, stop oscillator)	-----

C. MASK ORDER SHEET

Refer to next page.

Mask Order & Verification Sheet

MC80C04 - MD

48 : 48K
32 : 32K
24 : 24K

K : 64SDIP
Q : 64MQFP
L : 64LQFP

Customer should write inside thick line box.

1. Customer Information

Company Name			
Application			
Order Date	YYYY	MM	DD
Tel:	Fax:		
E-mail address:			
Name & Signature:			

2. Device Information

Package	<input type="checkbox"/> 64MQFP	<input type="checkbox"/> 64LQFP	<input type="checkbox"/> 64SDIP
Mask Data	File Name	() .OTP	
	ROM Size (bytes)	<input type="checkbox"/> 24K	<input type="checkbox"/> 32K <input type="checkbox"/> 48K
	Check Sum	()	
	* PFD Option	Set "00 _H " in blanked area	
	<input type="checkbox"/> 2.7V	(48K) 4000 _H	.OTP file
	<input type="checkbox"/> 2.7V	(32K) 8000 _H	
	<input type="checkbox"/> 3.0V	(24K) C000 _H	
	<input type="checkbox"/> 2.4V	FFFF _H	

(Please check mark \checkmark into)

3. Marking Specification

<input type="checkbox"/>	<p>MC80C04XXX-MD <input type="checkbox"/> <input type="checkbox"/> <input type="checkbox"/></p> <p>YYWW KOREA</p>	24 or 32 or 48
<input type="checkbox"/>	<p>Customer's logo</p> <p>MC80C04XXX-MD <input type="checkbox"/> <input type="checkbox"/> <input type="checkbox"/></p> <p>YYWW KOREA</p>	Customer logo is not required. <input type="checkbox"/>

If the customer logo must be used in the special mark, please submit a clean original of the logo.

Customer's part number

4. Delivery Schedule

	Date	Quantity	MagnaChip Confirmation
Customer sample	YYYY MM DD • •	pcs	
Risk order	YYYY MM DD • •	pcs	

5. ROM Code Verification

Please confirm out verification data.

Verification date:	YYYY	MM	DD
Check sum:			
Tel:	Fax:		
E-mail address:			
Name & Signature:			

Approval date:	YYYY	MM	DD
<i>I agree with your verification data and confirm you to make mask set.</i>			
Tel:	Fax:		
E-mail address:			
Name & Signature:			

MagnaChip