

STRUCTURE Silicon Monolithic Integrated Circuit

PRODUCT SERIES 5ch Stepping Motor Driver

TYPE **BD6754KN**

FEATURES • Built in 4 PWM Constant-Current Drivers
 • Built in 1 Linear Constant-Current Driver

●Absolute maximum ratings (Ta=25°C)

Parameter	Symbol	Limit	Unit
Power supply voltage	VCC	-0.5 to +7.0	V
Motor power supply voltage	VM	-0.5 to +7.0	V
Control input voltage	VIN	-0.5 to VCC+0.5	V
Power dissipation	Pd	875 ^{*1}	mW
Operating temperature range	Topr	-20 to +75	°C
Junction temperature	Tjmax	150	°C
Storage temperature range	Tstg	-55 to +150	°C
H-bridge output current	Iout	-800 to +800 ^{*2}	mA/ch

^{*1} Reduced by 7.0mW/°C over 25°C, when mounted on a glass epoxy board (70mm × 70mm × 1.6mm).

^{*2} Must not exceed Pd, ASO, or Tjmax of 150°C.

●Operating Conditions (Ta= -25°C to +75°C)

Parameter	Symbol	Min.	Typ.	Max.	Unit
Power supply voltage	VCC	2.7	3.3	5.5	V
Motor power supply voltage	VM	2.7	3.3	5.5	V
Control input voltage	VIN	0	-	VCC	V
PWM signal input frequency	FPWM	0	-	0.1	MHz
Serial clock input frequency	FSCLK	0	-	10	MHz
Master clock input frequency	FMCLK	0	-	2	MHz
H-bridge output current	Iout	-	-	±500 ^{*3}	mA/ch

^{*3} Must not exceed Pd or ASO.

The product described in this specification is a strategic product (and/or service) subject to COCOM regulations. It should not be exported without authorization from the appropriate government authorities. This product isn't designed for protection against radioactive rays.

●Package Outline

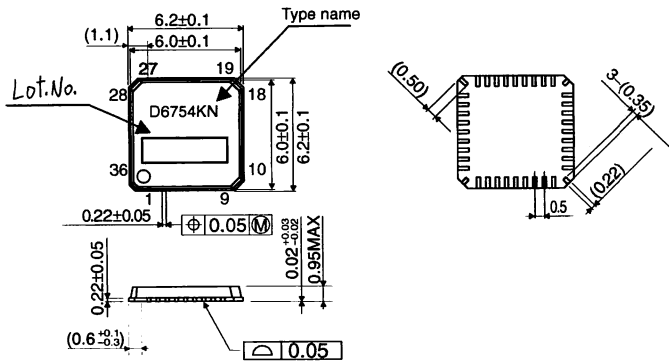

Fig.1 VQFN36 Package (Unit: mm)

●Pin Arrangement (Top View)

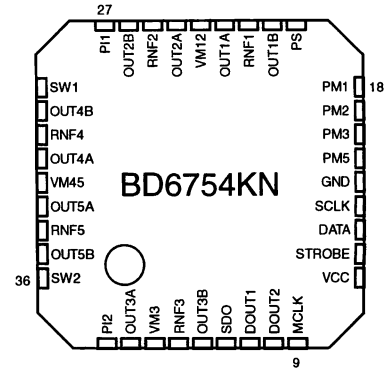

Fig.2 BD6754KN Pin Arrangement (Top View)

●Block Diagram

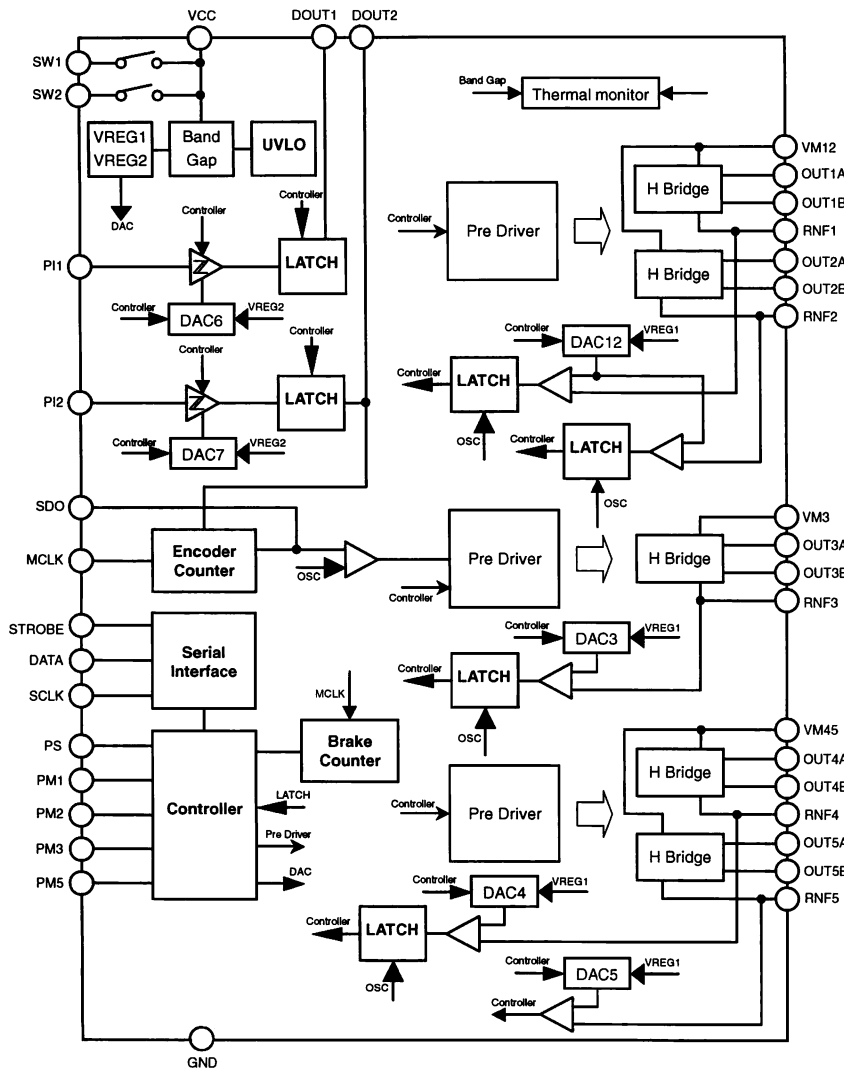

Fig.3 BD6754KN Block Diagram

●Pin No. and Pin Name

No.	Pin name	No.	Pin name
1	PI2	19	PS
2	OUT3A	20	OUT1B
3	VM3	21	RNF1
4	RNF3	22	OUT1A
5	OUT3B	23	VM12
6	SDO	24	OUT2A
7	DOUT1	25	RNF2
8	DOUT2	26	OUT2B
9	MCLK	27	PI1
10	VCC	28	SW1
11	STROBE	29	OUT4B
12	DATA	30	RNF4
13	SCLK	31	OUT4A
14	GND	32	VM45
15	PM5	33	OUT5A
16	PM3	34	RNF5
17	PM2	35	OUT5B
18	PM1	36	SW2

●BD6754KN Electrical Characteristics (Unless otherwise specified, Ta=25°C, VCC=3.3V, VM=3.3V)

Parameter	Symbol	Limit			Unit	Conditions
		Min.	Typ.	Max.		
Overall						
Circuit current during standby operation	ICCST	-	0	1	μA	PS=L
Circuit current	ICC	2.0	4.0	7.5	mA	PS=H with no signal
Control input						
High level input voltage	VINH	2.0	-	VCC	V	
Low level input voltage	VINL	0	-	0.7	V	
High level input current 1	IINH1	16.5	33	66	μA	PM1~PM5, MCLK, PS; VIN=3.3V
High level input current 2	IINH2	8.2	16.5	33	μA	STROBE, DATA, SCLK; VIN=3.3V
Low level input current	IINL	-3	0	3	μA	PM1~PM5, MCLK, PS, STROBE, DATA, SCLK; VIN=0V
Pull-down resistor 1	RIN1	50	100	200	kΩ	PM1~PM5, MCLK, PS
Pull-down resistor 2	RIN2	100	200	400	kΩ	STROBE, DATA, SCLK
UVLO						
UVLO voltage	VUVLO	1.75	-	2.25	V	
PWM Constant-Current Drive block (ch1 to ch4)						
Output ON-Resistance	RON	-	1.4	1.7	Ω	Io=±400mA on high and low sides in total
Output limit voltage 1	VLIM1	94	104	114	mV	DAC=4'b0101(ch1~ch2), DAC=6'b010101(ch3~ch4)
Output limit voltage 2	VLIM2	250	290	330	mV	DAC=4'b1111(ch1~ch2), DAC=6'b111111(ch3~ch4)
Output OFF time 1	TOFF1	0.5	1.0	2.0	μs	off-t=1
Output OFF time 2	TOFF2	1.0	2.0	4.0	μs	off-t=0
Output minimum ON time	TMINON	0.1	0.2	0.4	μs	
Linear Constant-Current Drive block (ch5)						
Output ON-Resistance	RON	-	1.4	1.7	Ω	Io=±400mA on high and low sides in total
Output limit voltage 1	VLIM1	98	104	110	mV	DAC=6'b010101
Output limit voltage 2	VLIM2	255	290	325	mV	DAC=6'b111111
PI comparator						
In-phase input voltage range	VLOPI	0	-	VCC-1.5	V	
Input bias current	IBIPI	-3	0	3	μA	When PI1=PI2=0V
Input offset voltage	VOFPI	-30	0	30	mV	
Output low level voltage	VLOPI	0	0.5	1.0	V	With 1mA sink current
Output high level voltage	VHIPI	VCC-1	VCC-0.5	VCC	V	With 1mA source current
Threshold voltage 1	VTHPI1	0.8	1.0	1.2	V	DAC=4'b1000
Threshold voltage 2	VTHPI2	1.5	1.875	2.25	V	DAC=4'b1111
Upper hysteresis width 9	VHYS9PI	+0.22	+0.44	+0.66	V	PI hysteresis setting 1 and 2=4'b1000 (VTHPI center)
Lower hysteresis width 9	VHYS9PI	-0.19	-0.36	-0.53	V	PI hysteresis setting 1 and 2=4'b1000 (VTHPI center)
Speed discriminator						
PWM oscillating frequency	FPWM	50	100	200	kHz	
SDO charge current 5	ISDOD5	-75	-50	-25	μA	Charge pump setting=3b'100
SDO discharge current 5	ISDOD5	+25	+50	+75	μA	Charge pump setting=3b'100
Analog Switch						
ON-Resistance	RONSW	-	250	500	Ω	With 1mA source current

●Operation Notes

(1) Absolute maximum ratings

Use of the IC in excess of absolute maximum ratings such as the applied voltage or operating temperature range (Topr) may result in IC damage. Assumptions should not be made regarding the state of the IC (short mode or open mode) when such damage is suffered. The implementation of a physical safety measure such as a fuse should be considered when use of the IC in a special mode where the absolute maximum ratings may be exceeded is anticipated.

(2) Power supply lines

Regenerated current may flow as a result of the motor's back electromotive force. Insert capacitors between the power supply and ground pins to serve as a route for regenerated current. Determine the capacitance in full consideration of all the characteristics of the electrolytic capacitor, because the electrolytic capacitor may lose some capacitance at low temperatures. If the connected power supply does not have sufficient current absorption capacity, regenerative current will cause the voltage on the power supply line to rise, which combined with the product and its peripheral circuitry may exceed the absolute maximum ratings. It is recommended to implement a physical safety measure such as the insertion of a voltage clamp diode between the power supply and GND pins.

(3) Ground potential

Ensure a minimum GND pin potential in all operating conditions.

(4) Setting of heat

Use a thermal design that allows for a sufficient margin in light of the power dissipation (Pd) in actual operating conditions.

(5) Actions in strong magnetic field

Use caution when using the IC in the presence of a strong magnetic field as doing so may cause the IC to malfunction.

(6) ASO

When using the IC, set the output transistor for the motor so that it does not exceed absolute maximum ratings or ASO.

(7) Thermal shutdown circuit

This IC incorporates a TSD (thermal shutdown) circuit (TSD circuit). If the temperature of the chip reaches the following temperature, the motor coil output will be opened. The thermal shutdown circuit (TSD circuit) is designed only to shut the IC off to prevent runaway thermal operation. It is not designed to protect the IC or guarantee its operation. Do not continue to use the IC after operating this circuit or use the IC in an environment where the operation of this circuit is assumed.

TSD ON temperature [°C] (Typ.)	Hysteresis temperature [°C] (Typ.)
175	20

(8) Ground Wiring Pattern

When using both small signal and large current GND patterns, it is recommended to isolate the two ground patterns, placing a single ground point at the application's reference point so that the pattern wiring resistance and voltage variations caused by large currents do not cause variations in the small signal ground voltage. Be careful not to change the GND wiring pattern of any external components, either.

Notes

- No technical content pages of this document may be reproduced in any form or transmitted by any means without prior permission of ROHM CO.,LTD.
- The contents described herein are subject to change without notice. The specifications for the product described in this document are for reference only. Upon actual use, therefore, please request that specifications to be separately delivered.
- Application circuit diagrams and circuit constants contained herein are shown as examples of standard use and operation. Please pay careful attention to the peripheral conditions when designing circuits and deciding upon circuit constants in the set.
- Any data, including, but not limited to application circuit diagrams information, described herein are intended only as illustrations of such devices and not as the specifications for such devices. ROHM CO.,LTD. disclaims any warranty that any use of such devices shall be free from infringement of any third party's intellectual property rights or other proprietary rights, and further, assumes no liability of whatsoever nature in the event of any such infringement, or arising from or connected with or related to the use of such devices.
- Upon the sale of any such devices, other than for buyer's right to use such devices itself, resell or otherwise dispose of the same, no express or implied right or license to practice or commercially exploit any intellectual property rights or other proprietary rights owned or controlled by
- ROHM CO., LTD. is granted to any such buyer.
- Products listed in this document are no antiradiation design.

The products listed in this document are designed to be used with ordinary electronic equipment or devices (such as audio visual equipment, office-automation equipment, communications devices, electrical appliances and electronic toys).

Should you intend to use these products with equipment or devices which require an extremely high level of reliability and the malfunction of which would directly endanger human life (such as medical instruments, transportation equipment, aerospace machinery, nuclear-reactor controllers, fuel controllers and other safety devices), please be sure to consult with our sales representative in advance.

About Export Control Order in Japan

Products described herein are the objects of controlled goods in Annex 1 (Item 16) of Export Trade Control Order in Japan.

In case of export from Japan, please confirm if it applies to "objective" criteria or an "informed" (by MITI clause) on the basis of "catch all controls for Non-Proliferation of Weapons of Mass Destruction.

Thank you for your accessing to ROHM product informations.
More detail product informations and catalogs are available,
please contact your nearest sales office.

Please contact our sales offices for details ;

U.S.A / San Diego	TEL : +1(858)625-3630	FAX : +1(858)625-3670
Atlanta	TEL : +1(770)754-5972	FAX : +1(770)754-0691
Dallas	TEL : +1(972)312-8818	FAX : +1(972)312-0330
Germany / Dusseldorf	TEL : +49(2154)9210	FAX : +49(2154)921400
United Kingdom / London	TEL : +44(1)908-282-666	FAX : +44(1)908-282-528
France / Paris	TEL : +33(0)1 56 97 30 60	FAX : +33(0) 1 56 97 30 80
China / Hong Kong	TEL : +852(2)740-6262	FAX : +852(2)375-8971
Shanghai	TEL : +86(21)6279-2727	FAX : +86(21)6247-2066
Dilian	TEL : +86(411)8230-8549	FAX : +86(411)8230-8537
Beijing	TEL : +86(10)8525-2483	FAX : +86(10)8525-2489
Taiwan / Taipei	TEL : +866(2)2500-6956	FAX : +866(2)2503-2869
Korea / Seoul	TEL : +82(2)8182-700	FAX : +82(2)8182-715
Singapore	TEL : +65-6332-2322	FAX : +65-6332-5662
Malaysia / Kuala Lumpur	TEL : +60(3)7958-8355	FAX : +60(3)7958-8377
Philippines / Manila	TEL : +63(2)807-6872	FAX : +63(2)809-1422
Thailand / Bangkok	TEL : +66(2)254-4890	FAX : +66(2)256-6334

Japan /
(Internal Sales)

Tokyo	2-1-1, Yaesu, Chuo-ku, Tokyo 104-0082	TEL : +81(3)5203-0321	FAX : +81(3)5203-0300
Yokohama	2-4-8, Shin Yokohama, Kohoku-ku, Yokohama, Kanagawa 222-8575	TEL : +81(45)476-2131	FAX : +81(45)476-2128
Nagoya	Dainagayo Building 9F 3-28-12, Meieki, Nakamura-ku, Nagoya, Aichi 450-0002	TEL : +81(52)581-8521	FAX : +81(52)561-2173
Kyoto	579-32 Higashi Shiokouji-cho, Karasuma Nishi-iru, Shiokoujidori, Shimogyo-ku, Kyoto 600-8216	TEL : +81(75)311-2121	FAX : +81(75)314-6559

(Contact address for overseas customers in Japan)

Yokohama	TEL : +81(45)476-9270	FAX : +81(045)476-9271
----------	-----------------------	------------------------