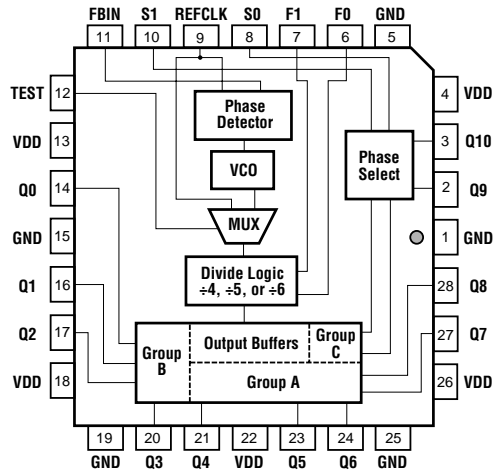

Figure 1. Block Diagram



TriQuint's GA1085 is a configurable clock buffer which generates 11 outputs and operates over a wide range of frequencies—from 24 MHz to 105 MHz. The outputs are available at either 1x and 2x or at 1x and $\frac{1}{2}$ x the reference clock frequency, f_{REF} . When one of the Group A outputs (Q4–Q8) is used as feedback to the PLL, all Group A outputs will be at f_{REF} , and all Group B (Q0–Q3) and Group C (Q9, Q10) outputs will be at $\frac{1}{2} \times f_{REF}$. When one of the Group B outputs is used as feedback to the PLL, all Group A outputs will be at $2 \times f_{REF}$ and all Group B and Group C outputs will be at f_{REF} . The Shift Select pins select the phase shift ($-2t$, $-t$, $+t$ or $+2t$) for Group C outputs (Q9, Q10) with respect to REFCLK. The phase shift increment (t) is equivalent to the VCO's period ($1/f_{VCO}$).

A very stable internal Phase-Locked Loop (PLL) provides low-jitter operation. This completely self-contained PLL requires no external capacitors or resistors. The PLL's Voltage-Controlled Oscillator (VCO) has a frequency range from 280 MHz to 420 MHz. By feeding back one of the output clocks to FBIN, the PLL continuously maintains frequency and phase synchronization between the reference clock (REFCLK) and each of the outputs.

TriQuint's patented output buffer design delivers a very low output-to-output skew of 150 ps (max). The GA1085's symmetrical TTL outputs are capable of sourcing and sinking 30 mA.

GA1085

11-Output Configurable Clock Buffer

Features

- Wide frequency range:
24 MHz to 105 MHz
- Output configurations:
Four outputs at f_{REF}
Four outputs at $f_{REF}/2$
Two outputs at $f_{REF}/2$
with adjustable phase
or
Five outputs at $2 \times f_{REF}$
Three outputs at f_{REF}
Two outputs at f_{REF}
with adjustable phase
- Selectable Phase Shift: $-2t$, $-t$, $+t$, and $+2t$ ($t = 1/f_{VCO}$)
- Low output-to-output skew: 150 ps (max) within a group
- Near-zero propagation delay:
 $-350 \text{ ps} \pm 1000 \text{ ps}$ (max)
- TTL-compatible with 30 mA output drive
- 28-pin J-lead surface-mount package

Functional Description

The core of the GA1085 is a Phase-Locked Loop (PLL) that continuously compares the reference clock (REFCLK) to the feedback clock (FBIN), maintaining a zero frequency difference between the two. Since one of the outputs (Q0–Q8) is always connected to FBIN, the PLL keeps the propagation delay between the outputs and the reference clock within $-350 \text{ ps} \pm 1000 \text{ ps}$.

The internal Voltage-Controlled Oscillator (VCO) has an operating range of 280 MHz to 420 MHz. The combination of the VCO and the Divide Logic enables the GA1085 to operate between 24 MHz and 105 MHz. The device features six divide modes: $\div 4$, $\div 5$, $\div 6$, $\div 8$, $\div 10$, and $\div 12$. The Frequency Select pins, F0 and F1, and the output used as feedback to FBIN set the divide mode as shown in Table 1.

The Shift Select pins, S0 and S1, control the phase shift of Q9 and Q10 relative to the other outputs. The user can select from four incremental phase shifts as shown in Table 2.

Table 1. Frequency Mode Selection

Feedback: Any Group A Output (Q4 – Q8)

Test	Select Pins		Mode	Reference Clock Frequency Range	Output Frequency Range	
	F0	F1			Group A: Q4–Q8	B: Q0–Q3, C: Q9–Q10
0	1	0	$\div 4$	70 MHz – 105 MHz	70 MHz – 105 MHz	35 MHz – 52 MHz
0	0	0	$\div 5$	56 MHz – 84 MHz	56 MHz – 84 MHz ¹	28 MHz – 42 MHz
0	0	1	$\div 6$	48 MHz – 70 MHz	48 MHz – 70 MHz	24 MHz – 35 MHz
0	1	1	Not Used	N.A.	N.A.	N.A.

Feedback: Any Group B Output (Q0 – Q3)

Test	Select Pins		Mode	Reference Clock Frequency Range	Output Frequency Range	
	F0	F1			Group A: Q4–Q8	B: Q0–Q3, C: Q9–Q10
0	1	0	$\div 8$	35 MHz – 52 MHz	70 MHz – 105 MHz	35 MHz – 52 MHz
0	0	0	$\div 10$	28 MHz – 42 MHz	56 MHz – 84 MHz ¹	28 MHz – 42 MHz
0	0	1	$\div 12$	24 MHz – 35 MHz	48 MHz – 70 MHz	24 MHz – 35 MHz
0	1	1	Not Used	N.A.	N.A.	N.A.

Note: 1. This mode produces outputs with 40/60 duty cycle for Q4 – Q8 only.

The phase-shift increment (t) is calculated using the following equation:

$$t = \frac{1}{(f_{\text{REF}})(n)}$$

where n is the divide mode.

In the test mode, the PLL is bypassed and REFCLK is connected directly to the Divide Logic block via the MUX, as shown in Figure 1. This mode is useful for debug and test purposes. The various test modes are outlined in Table 3. In the test mode, the frequency of the reference clock is divided by 4, 5, or 6.

The maximum rise and fall time at the output pins is 1.4 ns. All outputs of the GA1085 are TTL-compatible with 30 mA symmetric drive and a minimum V_{OH} of 2.4 V.

Power-Up/Reset Synchronization

After power-up or reset, the PLL requires time before it achieves synchronization lock. The maximum time required for synchronization (TSYNC) is 500 ms.

Table 2. Phase Shift Selection

<i>S0</i>	<i>S1</i>	<i>Phase Difference (Q9, Q10)</i>
0	0	+2t
0	1	+t
1	0	-t
1	1	-2t

Table 3. Test Mode Selection

<i>Test</i>	<i>F0</i>	<i>F1</i>	<i>Mode</i>	<i>Ref. Clock</i>	<i>Group A: Outputs Q4–Q8</i>	<i>Groups B, C: Q0–Q3, Q9, Q10</i>
1	1	0	÷ 4	f_{REF}	$f_{REF} \div 4$	$f_{REF} \div 8$
1	0	0	÷ 5	f_{REF}	$f_{REF} \div 5$	$f_{REF} \div 10$
1	0	1	÷ 6	f_{REF}	$f_{REF} \div 6$	$f_{REF} \div 12$
1	1	1	—	—	—	—

Layout Guidelines

Multiple ground and power pins on the GA1085 reduce ground bounce. Good layout techniques, however, are necessary to guarantee proper operation and to meet the specifications across the full operating range. TriQuint recommends bypassing each of the V_{DD} supply pins to the nearest ground pin, as close to the chip as possible.

Figure 2 shows the recommended power layout for the GA1085. The bypass capacitors should be located on the same side of the board as the GA1085. The V_{DD} traces connect to an inner-layer V_{DD} plane. All of the ground pins (GND) are connected to a small ground plane on the surface beneath the chip. Multiple through-holes connect this small surface plane to an inner-layer ground plane. The capacitors (C1–C5) are 0.1 μF . TriQuint's test board uses X7R temperature-stable capacitors in 1206 SMD cases.

Figure 2. Top Layer Layout of Power Pins
(magnified approximately 3.3x)

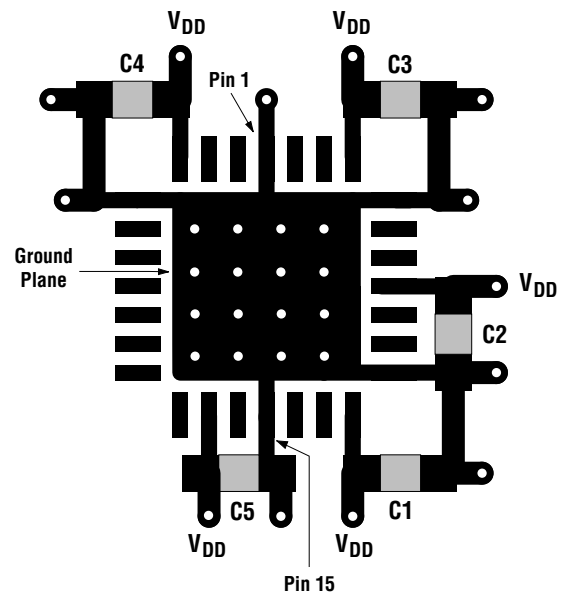

GA1085

Absolute Maximum Ratings¹

Storage temperature	-65 °C to +150 °C
Ambient temperature with power applied²	-55 °C to +100 °C
Supply voltage to ground potential	-0.5 V to +7.0 V
DC input voltage	-0.5 V to (V _{DD} + 0.5) V
DC input current	-30 mA to +5 mA
Package thermal resistance (MQuad)	θ _{JA} = 45 °C/W
Die junction temperature	T _J = 150 °C

DC Characteristics (V_{DD} = +5 V ± 5%, T_A = 0 °C to +70 °C)

Symbol	Description	Test Conditions	Min ³	Typ	Max ³	Unit
V _{OHT}	Output HIGH voltage	V _{DD} = Min I _{OH} = -30 mA V _{IN} = V _{IH} or V _{IL}	2.4	3.4		V
V _{OHC}	Output HIGH voltage	V _{DD} = Min I _{OH} = -1 mA V _{IN} = V _{IH} or V _{IL}	3.2	4.1		V
V _{OL}	Output LOW voltage	V _{DD} = Min I _{OL} = 30 mA V _{IN} = V _{IH} or V _{IL}		0.27	0.5	V
V _{IH} ⁴	Input HIGH level	Guaranteed input logical HIGH voltage for all Inputs	2.0			V
V _{IL} ⁴	Input LOW level	Guaranteed input logical LOW voltage for all inputs			0.8	V
I _{IL}	Input LOW current	V _{DD} = Max V _{IN} = 0.40 V		-156	-400	μA
I _{IH}	Input HIGH current	V _{DD} = Max V _{IN} = 2.7 V		0	25	μA
I _I	Input HIGH current	V _{DD} = Max V _{IN} = 5.5 V		2	1000	μA
I _{DDS} ⁵	Power supply current	V _{DD} = Max		119	160	mA
V _I	Input clamp voltage	V _{DD} = Min I _{IN} = -18 mA		-0.70	-1.2	V

Capacitance

Symbol	Description	Test Conditions	Min	Typ	Max	Unit
C _{IN} ⁶	Input capacitance	V _{IN} = 2.0 V at f = 1 MHz		6		pF

- Notes:
1. Exceeding these parameters may damage the device.
 2. Maximum ambient temperature with device not switching and unloaded.
 3. Typical limits are at V_{DD} = 5.0 V and T_A = 25 °C.
 4. These are absolute values with respect to device ground and all overshoots due to system or tester noise are included.
 5. This parameter is measured with device not switching and unloaded.
 6. These parameters are not 100% tested, but are periodically sampled.

AC Characteristics ($V_{DD} = +5 V \pm 5\%$, $T_A = 0^\circ C$ to $+70^\circ C$)

Symbol	Input Clock (REFCLK)	Test Conditions (Figure 3) ¹	Min	Typ	Max	Unit
t_{CPWH}	CLK pulse width HIGH	Figure 4	3	---	—	ns
t_{CPWL}	CLK pulse width LOW	Figure 4	3	---	—	ns
t_{IR}	Input rise time (0.8 V – 2.0 V)		—	—	2.0	ns
Output Clocks (Q0–Q10)						
t_{OR}, t_{OF}	Rise/fall time (0.8 V–2.0 V)	Figure 4	350	—	1400	ps
t_{PD}^2	CLK \hat{I} to FBIN \hat{I} (GA1085-MC1000)	Figure 4	–1350	–350	+650	ps
t_{SKEW1}^3	Rise–rise, fall–fall (within group)	Figure 5	—	60	150	ps
t_{SKEW2}^3	Rise–rise, fall–fall (group-to-group, aligned)	Figure 6 (skew2 takes into account skew1)	—	75	350	ps
t_{SKEW3}^3	Rise–rise, fall–fall (group-to-group, non-aligned)	Figure 7 (skew3 takes into account skew1, skew2)	—	—	650	ps
t_{SKEW4}^3	Rise–fall, fall–rise	Figure 8 (skew4 takes into account skew3)	—	—	1200	ps
t_{CYC}^4	Duty-cycle Variation	Figure 4	–1000	0	+1000	ps
t_{JP}^5	Period-to-Period Jitter	Figure 4	—	80	200	ps
t_{JR}^5	Random Jitter	Figure 4	—	190	400	ps
t_{SYNC}^6	Synchronization Time		—	10	500	μ s

- Notes:
1. All measurements are tested with a REFCLK having a rise time of 0.5 ns (0.8 V to 2.0 V).
 2. The PLL maintains alignment of CLK and FBIN at all times. This specification applies to the rising edge only because the input duty cycle can vary while the output duty cycle is typically 50/50. The delay t_{PD} is measured at the 1.5 V level between CLK and FBIN.
 3. Skew specifies the width of the window in which outputs switch, and is measured at 1.5 V.
 4. This specification represents the deviation from 50/50 on the outputs.
 5. Jitter specifications refer to peak-to-peak value. t_{JR} is the jitter on the output with respect to the reference clock. t_{JP} is the jitter on the output with respect to the output's previous rising edge.
 6. t_{SYNC} is the time required for the PLL to synchronize; this assumes the presence of a CLK signal and a connection from one of the outputs to FBIN.

Figure 3. AC Test Circuit

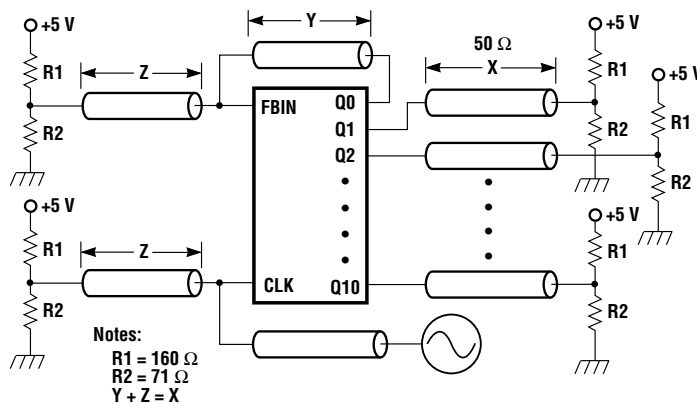

Switching Waveforms

Figure 3. General Timing

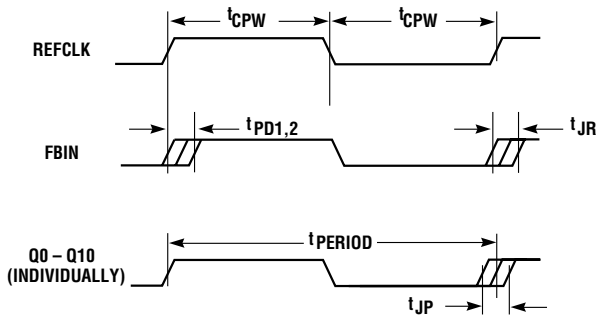

Figure 4. t_{SKEW1}

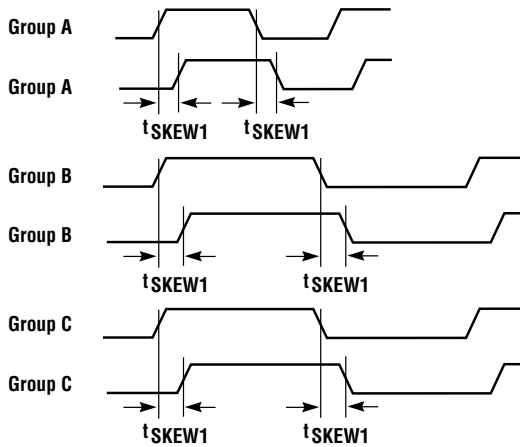

Figure 5. t_{SKEW2}

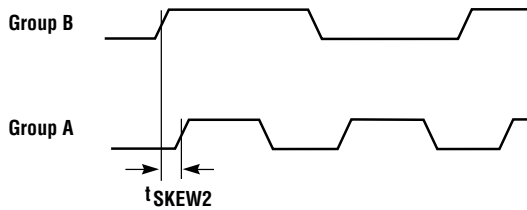
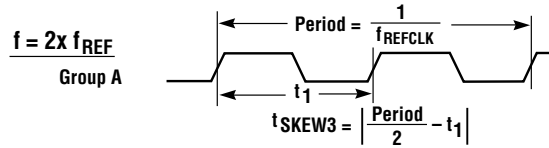
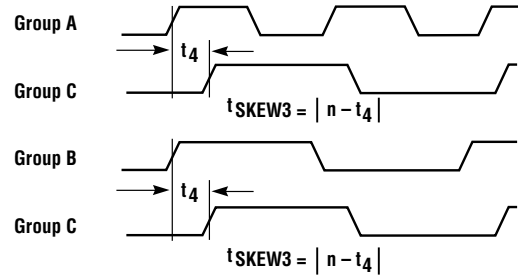

Figure 6. t_{SKEW3}

(For Group B Feedback)



(For Group A or B Feedback)



Note: "n" is the phase-shift increment: $2t, t, -t, -2t$.

Figure 7. t_{SKEW4}

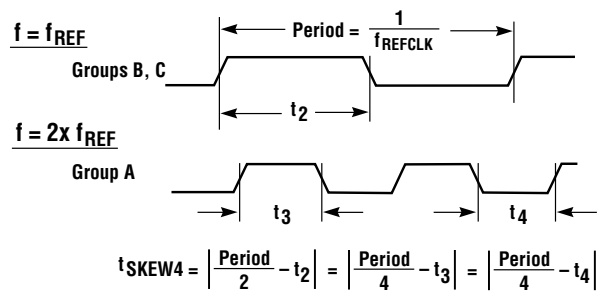

28-Pin MQuad J-Leaded Package Mechanical Specification

(All dimensions are in inches)

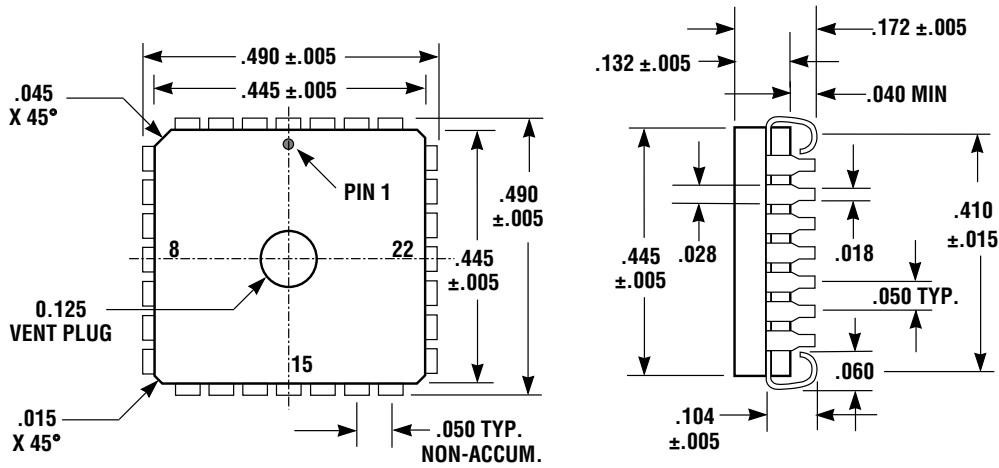

28-Pin MQuad Pin Description

Pin #	Pin Name	Description	I/O
1	GND	Ground	—
2	Q9	Output Clock 9 (C1)	0
3	Q10	Output Clock 10 (C2)	0
4	VDD	+5 V	—
5	GND	Ground	—
6	F0	Frequency Select 0	I
7	F1	Frequency Select 1	I
8	S0	Shift Select 0	I
9	REFCLK	Reference Clock	I
10	S1	Shift Select 1	I
11	FBIN	Feedback In	I
12	TEST	Test	I
13	VDD	+5 V	—
14	Q0	Output Clock 0 (B1)	0

Pin #	Pin Name	Description	I/O
15	GND	Ground	—
16	Q1	Output Clock 1 (B2)	0
17	Q2	Output Clock 2 (B3)	0
18	VDD	+5 V	—
19	GND	Ground	—
20	Q3	Output Clock 3 (B4)	0
21	Q4	Output Clock 4 (A1)	0
22	VDD	+5 V	—
23	Q5	Output Clock 5 (A2)	0
24	Q6	Output Clock 6 (A3)	0
25	GND	Ground	—
26	VDD	+5 V	—
27	Q7	Output Clock 7 (A4)	0
28	Q8	Output Clock 8 (A5)	0

SYSTEM TIMING PRODUCTS

Output Characteristics

The IV characteristics, transition times, package characteristics, device and bond-wire characteristics for the GA1085 are described in Tables 4 through 9 and Figures 9 through 11.

These output characteristics are provided for modelling purposes only. TriQuint does not guarantee the information in these tables and figures.

Figure 9. I_{OH} vs. V_{OH}

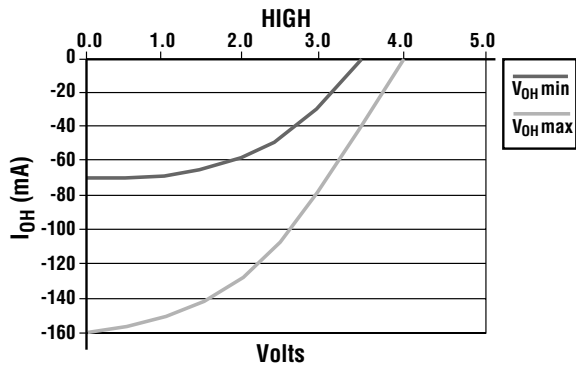

Table 4. I_{OH} vs. V_{OH}

V_{OH}	$I_{OH\ min}$ (mA)	$I_{OH\ max}$ (mA)
0.0	-70	-160
0.5	-70	-157
1.0	-68	-152
1.5	-65	-142
2.0	-59	-130
2.5	-48	-106
3.0	-29	-79
3.5	0	-42
4.0	0	0
4.5	0	0
5.0	0	0
6.0	0	0
7.0	0	0
8.0	0	0
9.0	0	1
10.0	0	5

Figure 10. I_{OL} vs. V_{OL}

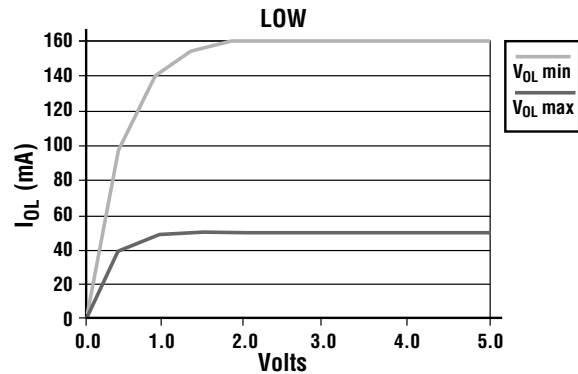

Table 5. I_{OL} vs. V_{OL}

V_{OL}	$I_{OL\ min}$ (mA)	$I_{OL\ max}$ (mA)
-2.5	-145	-435
-2.0	-135	-410
-1.5	-115	-350
-1.0	-90	-265
-0.5	-40	-120
0.0	0	0
0.5	37	97
1.0	49	140
1.5	53	155
2.0	54	157
2.5	54	159
3.0	54	160
3.5	54	160
4.0	54	160
4.5	54	160
5.0	54	160
10.0	54	160

Notes: 1. These are worst-case corners for process, voltage, and temperature.
2. Includes diode to ground current.

Table 6. Characteristics Above V_{DD} and Below Ground

Diode to GND		Diode Stack to VDD	
V	I (mA)	V	I (mA)
0.0	0	5.0	0
-0.4	0	6.0	0
-0.5	0	7.0	0
-0.6	-5	8.0	0
-0.7	-15	9.0	0
-0.8	-35	10.0	1
-0.9	-55	11.0	5
-1.0	-75	12.0	9
-2.0	-300		
-2.5	-350		
-3.0	-360		

Note: TriQuint does not guarantee diode operation for purposes other than ESD protection.

Figure 11. Output Model

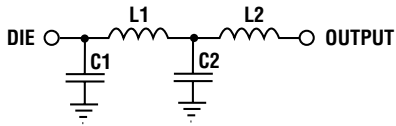

Table 7. Device and Bond-Wire Characteristics (Estimates)

L1	C1
2 nH	10 pF

Table 8. 28-Pin MQuad Package Characteristics

L2	C2
1.85 nH	0.40 pF

Table 9. Rise and Fall Times (Into 0 pF, 50 Ohms to 1.5 V)

Time (ns)	T_R min (V)	T_R max (V)	T_F min (V)	T_F max (V)
0.0	0.15	0.32	3.20	3.04
0.1	0.15	0.32	3.20	3.04
0.2	0.16	0.32	3.06	2.95
0.3	0.18	0.32	2.86	2.90
0.4	0.23	0.32	2.62	2.68
0.5	0.26	0.32	2.38	2.50
0.6	0.34	0.32	2.17	2.36
0.7	0.46	0.34	2.00	2.22
0.8	0.67	0.39	1.85	2.09
0.9	0.89	0.49	1.69	1.95
1.0	1.12	0.63	1.52	1.86
1.1	1.32	0.86	1.38	1.68
1.2	1.50	1.09	1.26	1.59
1.3	1.73	1.27	1.12	1.49
1.4	1.93	1.45	0.96	1.36
1.5	2.15	1.64	0.83	1.23
1.6	2.75	2.23	0.52	0.95
1.7	2.58	2.00	0.61	1.00
1.8	2.75	2.23	0.52	0.95
1.9	2.90	2.41	0.45	0.91
2.0	3.02	2.50	0.39	0.86
2.1	3.12	2.64	0.33	0.77
2.2	3.17	2.77	0.29	0.73
2.3	3.19	2.86	0.24	0.68
2.4	3.20	2.95	0.21	0.64
2.5	3.20	2.99	0.19	0.59
2.6	3.20	3.02	0.17	0.55
2.7	3.20	3.02	0.16	0.53
2.8	3.20	3.04	0.16	0.50
2.9	3.20	3.04	0.15	0.45
3.0	3.20	3.04	0.15	0.41
3.1	3.20	3.04	0.15	0.40
3.2	3.20	3.04	0.15	0.37
3.3	3.20	3.04	0.15	0.36
3.4	3.20	3.04	0.15	0.32
3.5	3.20	3.04	0.15	0.32

SYSTEM TIMING PRODUCTS

Ordering Information

To order, please specify as shown below:

GA1085-MC nnnn *11-Output Configurable Clock Buffer*

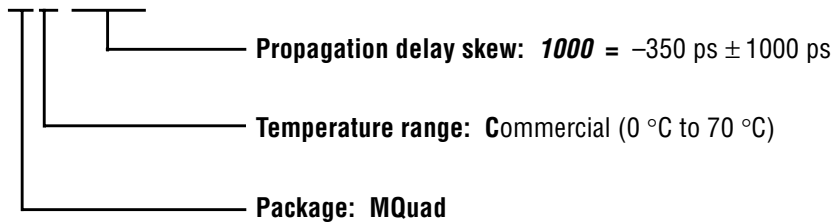

For latest specifications, additional product information,
worldwide sales and distribution locations, and information about TriQuint:

Web: www.triquint.com **Tel:** (503) 615-9000
Email: sales@tqs.com **Fax:** (503) 615-8900

For technical questions and additional information on specific applications:

Email: applications@tqs.com

The information provided herein is believed to be reliable; TriQuint assumes no liability for inaccuracies or omissions. TriQuint assumes no responsibility for the use of this information, and all such information shall be entirely at the user's own risk. Prices and specifications are subject to change without notice. No patent rights or licenses to any of the circuits described herein are implied or granted to any third party. TriQuint does not authorize or warrant any TriQuint product for use in life-support devices and/or systems.

Copyright © 1997 TriQuint Semiconductor, Inc. All rights reserved.
Revision 1.1.A November 1997