

Features

- Hermetic seal type for high reliability uses
- Wide operating temperature
- Glass lens(701H) or flat-glass window (703H)
- Unbiased for low frequency or biased for high frequency measurement

Applications

- Optical switches
- Optical encoders
- Pulse detector
- Optical data link
- Sensors and industrial controls

Maximum ratings

Item	Symbol	Value	Units
Reverse Voltage	V_R	15	V
Reverse Current	I_R	500	μA
Forward Current	I_F	150	mA
Operating Temperature	T_{op}	-40 ~ +125	$^{\circ}\text{C}$
Storage Temperature	T_{stg}	-55 ~ +125	$^{\circ}\text{C}$

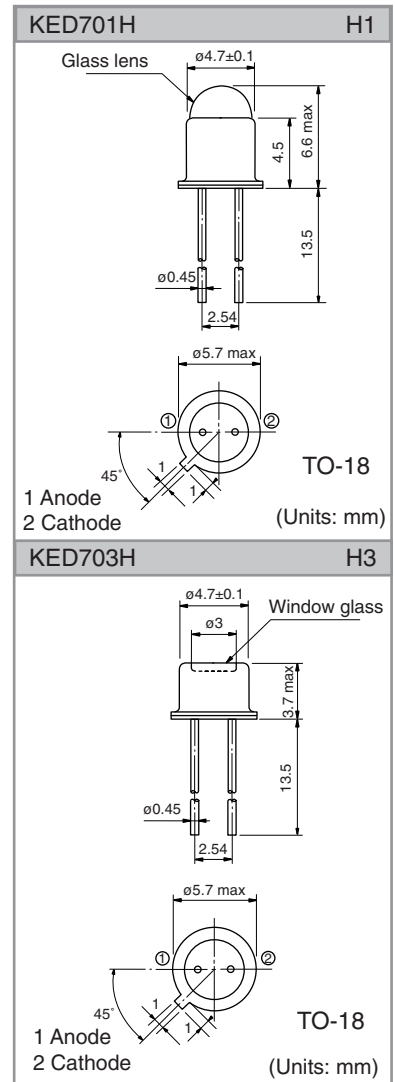

Characteristics ($T_a=25^{\circ}\text{C}$ unless otherwise noted.)

Parameter	Symbol	Min.	Typ.	Max.	Units	Test Conditions
Active Dia.	D	0.54x0.54			mm	
Operating Voltage	V_{R0}		0		V	For low frequency
			5			For high frequency
Sensitive Wavelength		400	880 (ρ)	1000	nm	ρ =Peak wavelength
Open Circuit Voltage	703H	V_{op}	320	390	mV	1000lux(@2856K)
	701H					
Short Circuit Current	703H	I_{sh}	0.5	1.5	μA	
	701H		7	15		
Dark Current	I_d		0.1	1	nA	$V_R=5\text{V}$
Capacitance	C		15	20	pF	$V=0, f=1\text{MHz}$
Rise/Fall Time	t_r		7	10	ns	$V_R=5\text{V}, \lambda=780\text{nm}, R_L=50$
	t_f		22	25		
Cutoff Frequency	f_c	8	10		MHz	$V_R=5\text{V}, \lambda=780\text{nm}, R_L=50$

KPD701H KPD703H

