

The MA5114 4k Static RAM is configured as 1024 x 4 bits and manufactured using CMOS-SOS high performance, radiation hard, 3µm technology.

The design uses a 6 transistor cell and has full static operation with no clock or timing strobe required. Address input buffers are deselected when Chip Select is in the HIGH state.

Operation Mode	CS	WE	I/O	Power
Read	L	H	D OUT	ISB1
Write	L	L	D IN	
Standby	H	X	High Z	ISB2

Figure 1: Truth Table

**FEATURES**

- 3µm CMOS-SOS Technology
- Latch-up Free
- Fast Access Time 90ns Typical
- Total Dose 10<sup>6</sup> Rad(Si)
- Transient Upset >10<sup>10</sup> Rad(Si)/sec
- SEU <10<sup>-10</sup> Errors/bitday
- Single 5V Supply
- Three State Output
- Low Standby Current 50µA Typical
- -55°C to +125°C Operation
- All Inputs and Outputs Fully TTL or CMOS Compatible
- Fully Static Operation
- Data Retention at 2V Supply

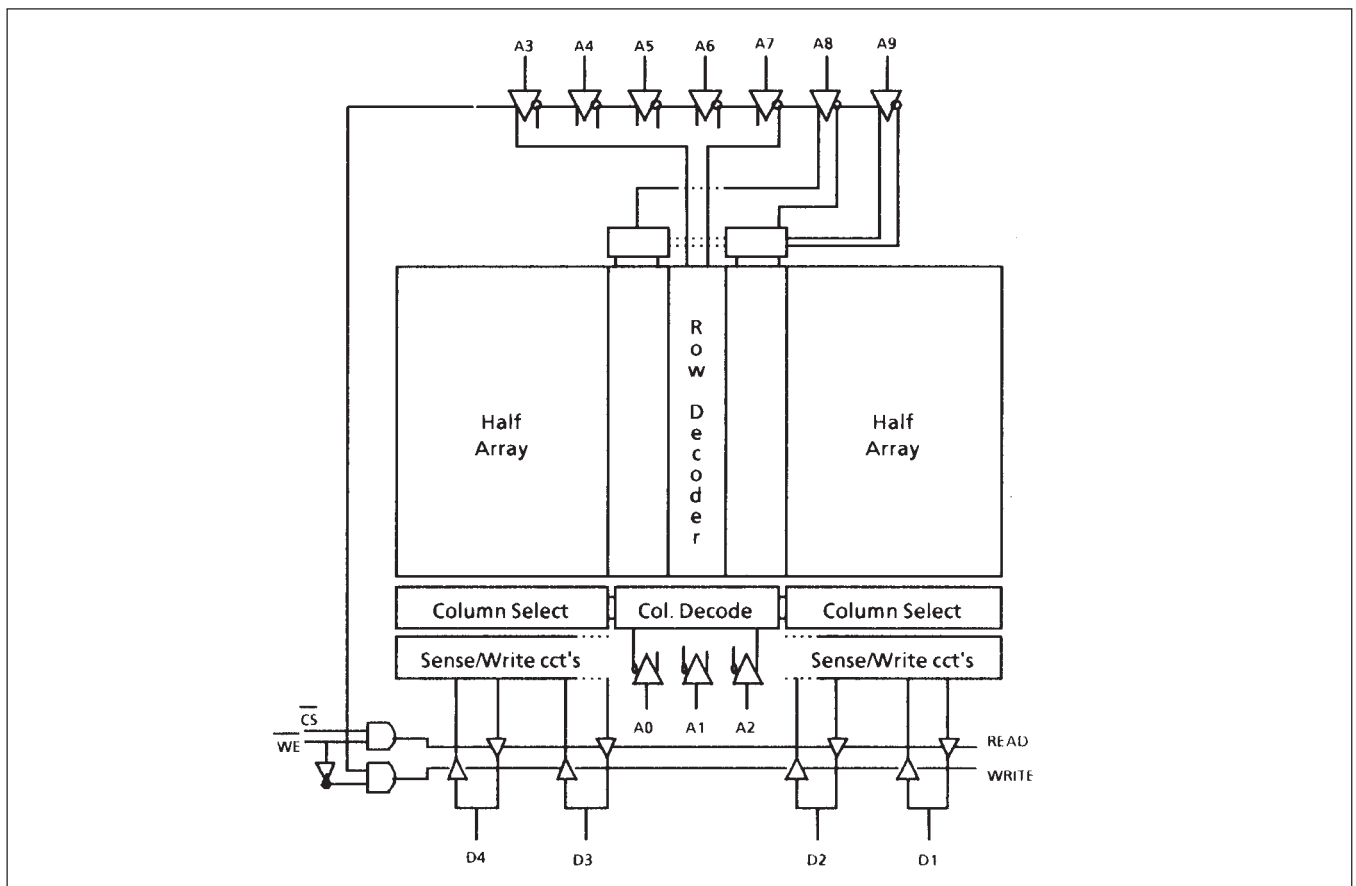

Figure 2: Block Diagram

# MA5114

## CHARACTERISTICS AND RATINGS

Symbol	Parameter	Min.	Max.	Units
$V_{CC}$	Supply Voltage	-0.5	7	V
$V_I$	Input Voltage	-0.3	$V_{DD}+0.3$	V
$T_A$	Operating Temperature	-55	125	°C
$T_S$	Storage Temperature	-65	150	°C

Stresses above those listed may cause permanent damage to the device. This is a stress rating only and functional operation of the device at these conditions, or at any other condition above those indicated in the operations section of this specification, is not Implied Exposure to absolute maximum rating conditions for extended periods may affect device reliability.

Figure 3: Absolute Maximum Ratings

Notes for Tables 4 and 5:

1. Characteristics apply to pre radiation at  $T_A = -55^{\circ}\text{C}$  to  $+125^{\circ}\text{C}$  with  $V_{DD} = 5V \pm 10\%$  and to post 100k Rad(Si) total dose radiation at  $T_A = 25^{\circ}\text{C}$  with  $V_{DD} = 5V \pm 10\%$  (characteristics at higher radiation levels available on request).
  2. Worst case at  $T_A = +125^{\circ}\text{C}$ , guaranteed but not tested at  $T_A = -55^{\circ}\text{C}$ .
- GROUP A SUBGROUPS 1, 2, 3.

Symbol	Parameter	Conditions	Min.	Typ.	Max.	Units
$V_{DD}$	Supply voltage	-	4.5	5.0	5.5	V
$V_{IH}$	Input High Voltage	-	$V_{DD}/2$	-	$V_{DD}$	V
$V_{IL}$	Input Low Voltage	-	$V_{SS}$	-	0.8	V
$V_{OH}$	Output High Voltage	$I_{OH1} = -1\text{mA}$	2.4	-	-	V
$V_{OL}$	Output Low Voltage	$I_{OL} = 2\text{mA}$	-	-	0.4	V
$I_{LI}$	Input Leakage Current (note 2)	All inputs except $\overline{CS}$	-	-	$\pm 10$	$\mu\text{A}$
$I_{LO}$	Output Leakage Current (note 2)	Output disabled, $V_{OUT} = V_{SS}$ or $V_{DD}$	-	-	$\pm 20$	$\mu\text{A}$
$I_{PUI}$	Input Pull-Up Current	$V_{IN} = V_{SS}$ on $\overline{CS}$ input only	-	-	-100	$\mu\text{A}$
$I_{PDI}$	Input Leakage Current	$V_{IN} = V_{SS}$ on $\overline{CS}$ input only	-	-	5	$\mu\text{A}$
$I_{DD}$	Power Supply Current	$f_{RC} = 1\text{MHz}$ , $\overline{CS} = 50\%$ mark:space-	12	16	mA	
$I_{SB1}$	Selected Supply Current	$\overline{CS} = V_{SS}$	-	25	35	mA
$I_{SB2}$	Standby Supply Current	Chip disabled	-	50	3000	$\mu\text{A}$

Figure 4: Electrical Characteristics

Symbol	Parameter	Conditions	Min.	Typ.	Max.	Units
$V_{DR}$	$V_{CC}$ for Data Retention	$\overline{CS} = V_{DR}$	2.0	-	-	V
$I_{DDR}$	Data Retention Current	$\overline{CS} = V_{DR}$ , $V_{DR} = 2.0\text{V}$	-	30	2000	$\mu\text{A}$

Figure 5: Data Retention Characteristics

## AC CHARACTERISTICS

Conditions of Test for Tables 5 and 6:

1. Input pulse =  $V_{SS}$  to 3.0V.
2. Times measurement reference level = 1.5V.
3. Transition is measured at  $\pm 500\text{mV}$  from steady state.
4. This parameter is sampled and not 100% tested.

Notes for Tables 6 and 7:

Characteristics apply to pre-radiation at  $T_A = -55^\circ\text{C}$  to  $+125^\circ\text{C}$  with  $V_{DD} = 5V \pm 10\%$  and to post 100k Rad(Si) total dose radiation at  $T_A = 25^\circ\text{C}$  with  $V_{DD} = 5V \pm 10\%$ . GROUP A SUBGROUPS 9, 10, 11.

Symbol	Parameter	Min	Max	Units
$T_{AVAVR}$	Read Cycle Time	135	-	ns
$T_{AVQV}$	Address Access Time	-	135	ns
$T_{ELQV}$	Chip Select to Output Valid	-	135	ns
$T_{ELQX}$ (3,4)	Chip Select to Output Active	10	-	ns
$T_{ELQZ}$ (3,4)	Chip Select to Output Tri State	10	50	ns
$T_{AXQX}$	Output Hold from Address Change	10	-	ns

Figure 6: Read Cycle AC Electrical Characteristics

Symbol	Parameter	Min	Max	Units
$T_{AVAVW}$	Write Cycle Time	135	-	ns
$T_{AVWL}$	Address Set Up Time	10	-	ns
$T_{WLWH}$	Write Pulse Width	50	-	ns
$T_{WHAV}$	Write Recovery Time	5	-	ns
$T_{DVWH}$	Data Set Up Time	35	-	ns
$T_{NHDX}$	Data Hold Time	5	-	ns
$T_{WLOZ}$ (3,4)	Write Enable to Output Tri State	10	50	ns
$T_{ELWL}$	Chip Selection to Write Low	25	-	ns
$T_{ELWH}$	Chip Selection to End of Write	85	-	ns
$T_{AVWH}$	Address Valid to End of Write	80	-	ns
$T_{WHQX}$ (3,4)	Output Active from End to Write	5	-	ns

Figure 7: Write Cycle AC Electrical Characteristics

Symbol	Parameter	Conditions	Min.	Typ.	Max.	Units
$C_{IN}$	Input Capacitance	$V_I = 0V$	-	6	10	pF
$C_{OUT}$	Output Capacitance	$V_O = 0V$	-	8	12	pF

Note:  $T_A = 25^\circ\text{C}$  and  $f = 1\text{MHz}$ . Data obtained by characterisation or analysis; not routinely measured.

Figure 8: Capacitance

## MA5114

Symbol	Parameter	Conditions
$F_T$	Basic Functionality	$V_{DD} = 4.5V - 5.5V$ , FREQ = 1MHz $V_{IL} = V_{SS}$ , $V_{IH} = V_{DD}$ , $V_{OL} \leq 1.5V$ , $V_{OH} \geq 1.5V$ TEMP = -55°C to +125°C, GPS PATTERN SET GROUP A SUBGROUPS 7, 8A, 8B

Figure 9: Functionality

Subgroup	Definition
1	Static characteristics specified in Tables 4 and 5 at +25°C
2	Static characteristics specified in Tables 4 and 5 at +125°C
3	Static characteristics specified in Tables 4 and 5 at -55°C
7	Functional characteristics specified in Table 9 at +25°C
8A	Functional characteristics specified in Table 9 at +125°C
8B	Functional characteristics specified in Table 9 at -55°C
9	Switching characteristics specified in Tables 6 and 7 at +25°C
10	Switching characteristics specified in Tables 6 and 7 at +125°C
11	Switching characteristics specified in Tables 6 and 7 at -55°C

Figure 10: Definition of Subgroups

TIMING DIAGRAMS

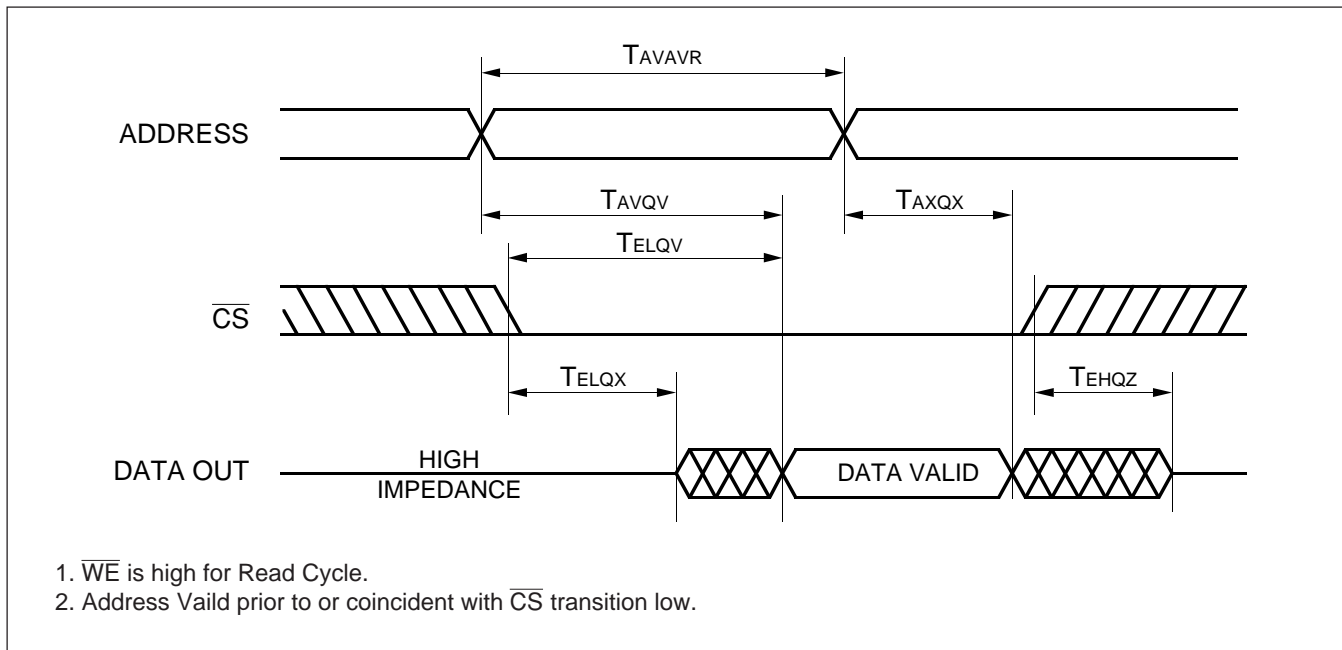

Figure 11a: Read Cycle 1

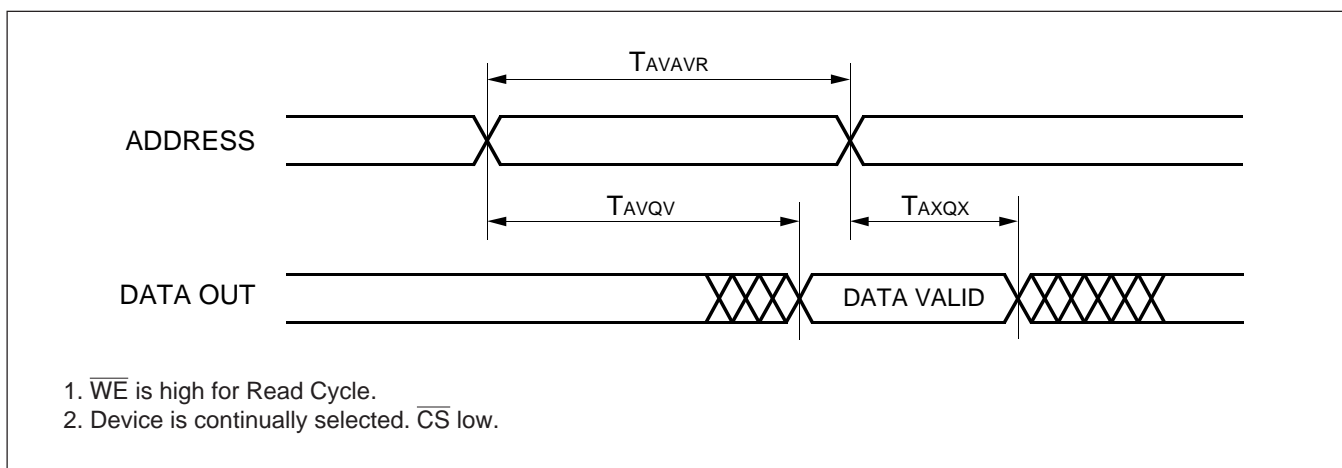

Figure 11b: Read Cycle 2

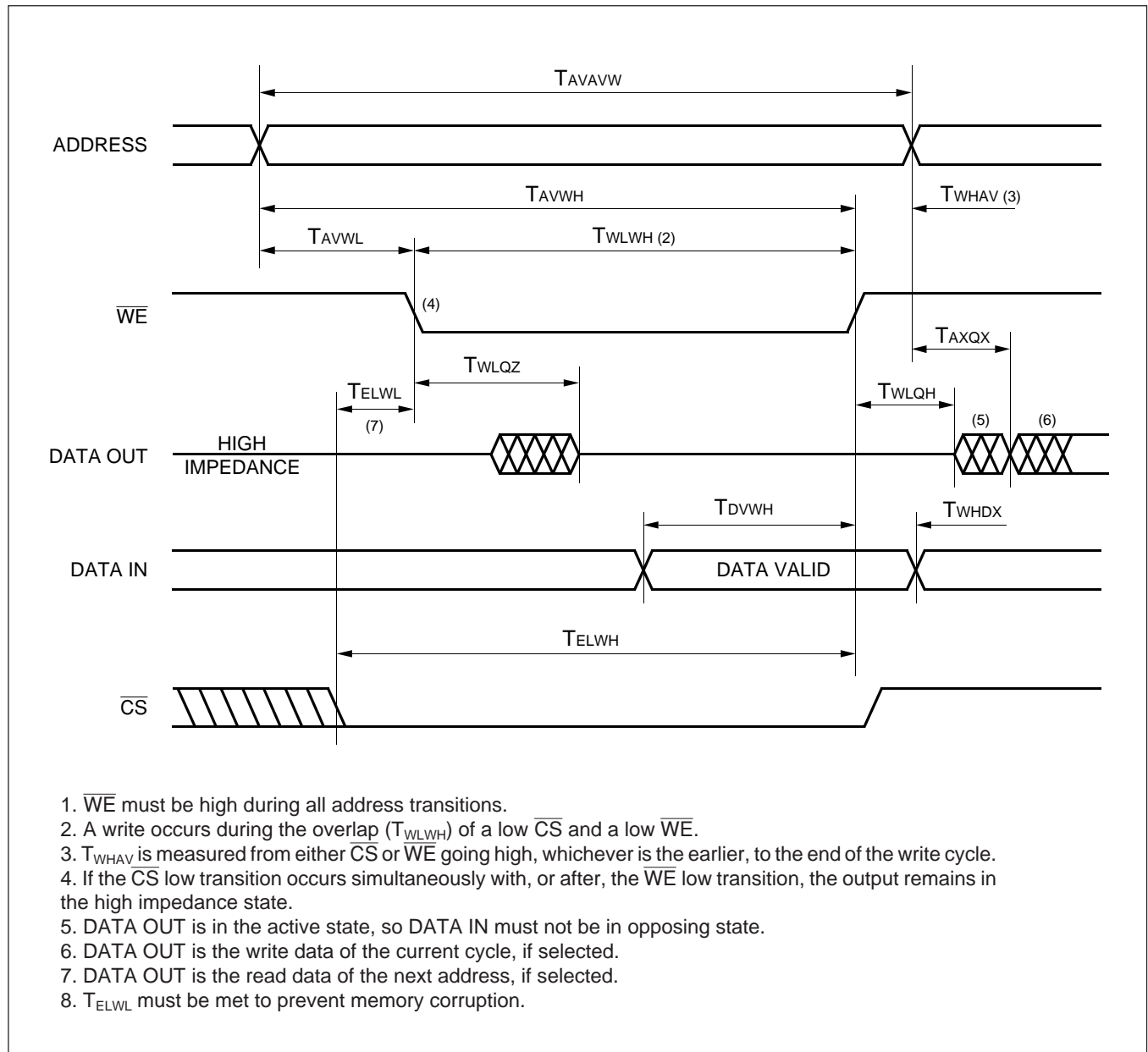
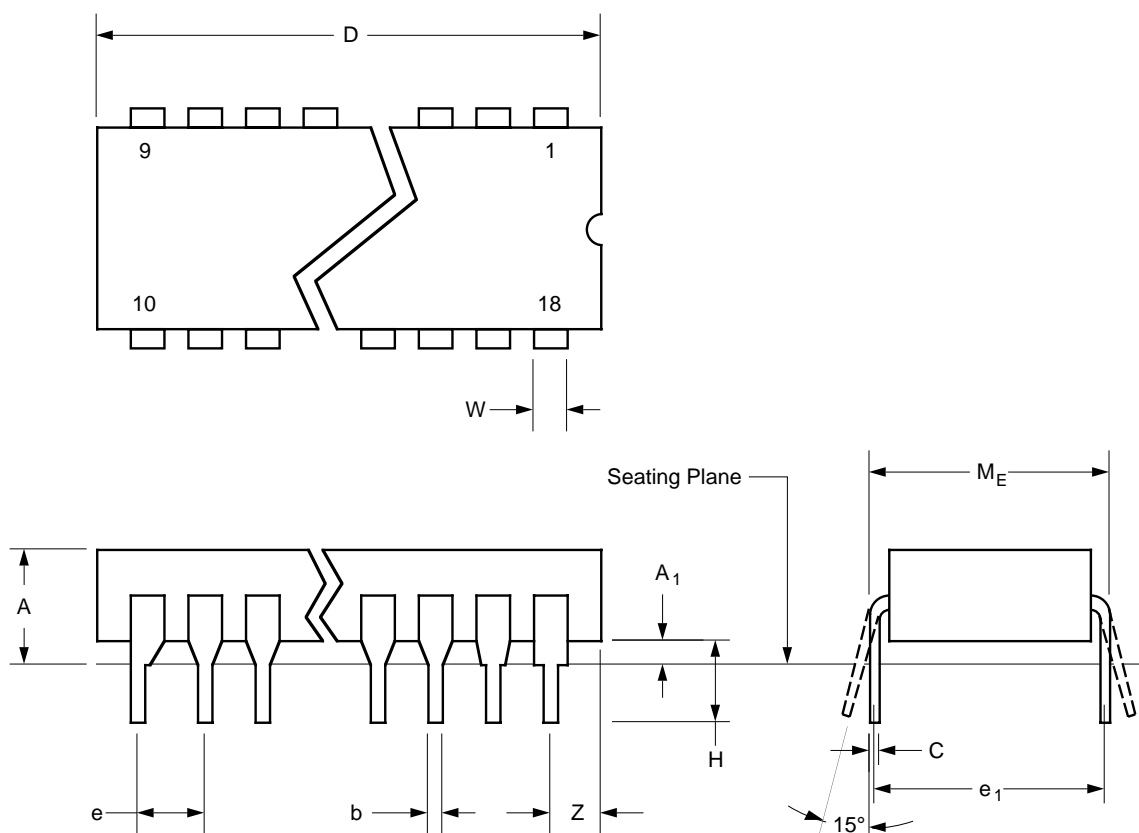
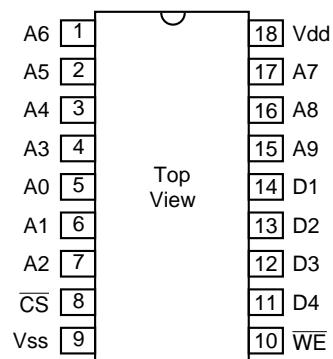

Figure 12: Write Cycle

OUTLINES AND PIN ASSIGNMENTS



Ref	Millimetres			Inches		
	Min.	Nom.	Max.	Min.	Nom.	Max.
A	-	-	5.715	-	-	0.225
A1	0.38	-	1.53	0.015	-	0.060
b	0.35	-	0.59	0.014	-	0.023
c	0.20	-	0.36	0.008	-	0.014
D	-	-	23.11	-	-	0.910
e	-	2.54 Typ.	-	-	0.100 Typ.	-
e1	-	8.13 Typ.	-	-	0.300 Typ.	-
H	4.44	-	5.38	0.175	-	0.212
Me	-	-	8.28	-	-	0.326
Z	-	-	1.27	-	-	0.050
W	-	-	1.53	-	-	0.060



XG406

Figure 13: 18-Lead Ceramic DIL (Solder Seal) - Package Style C

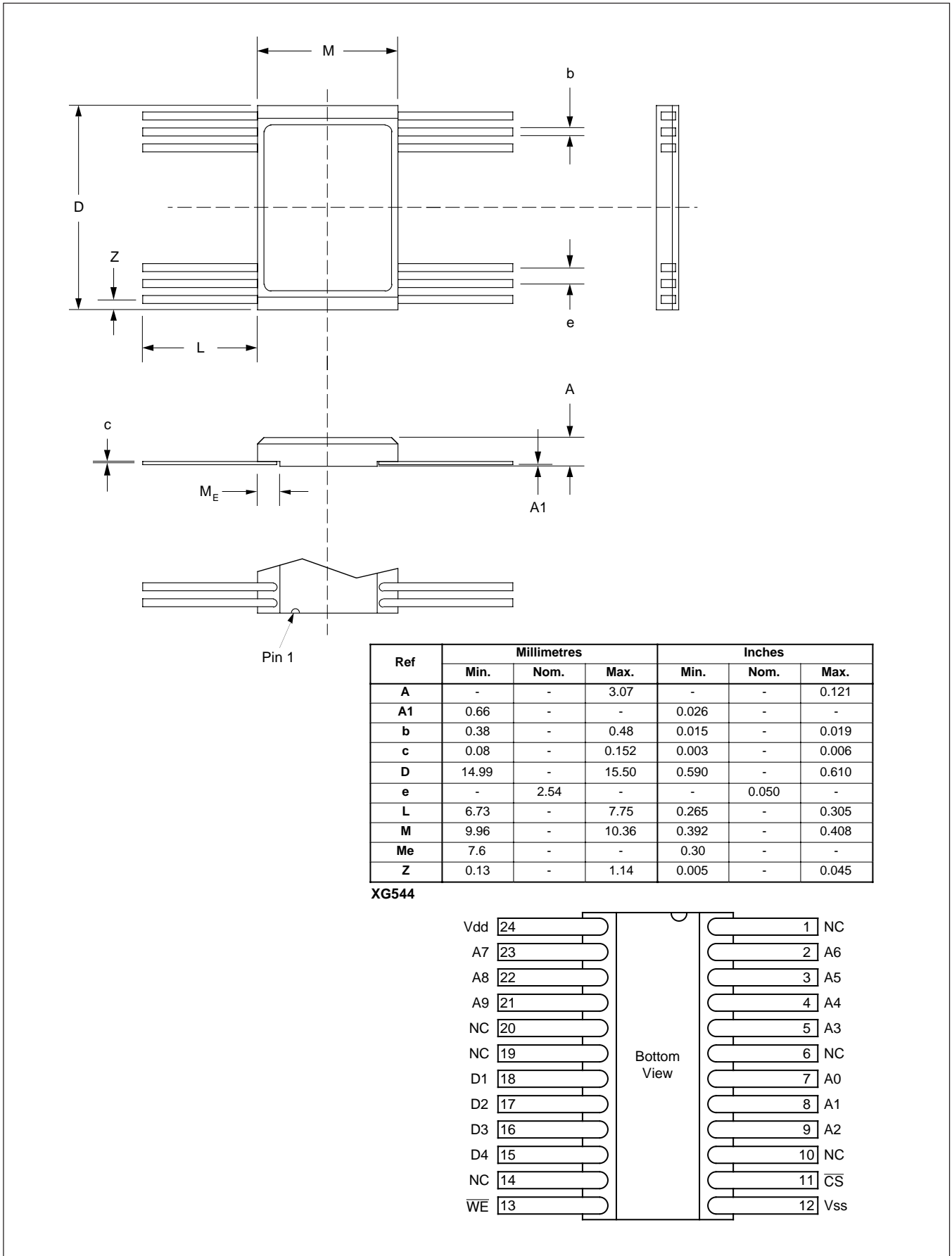
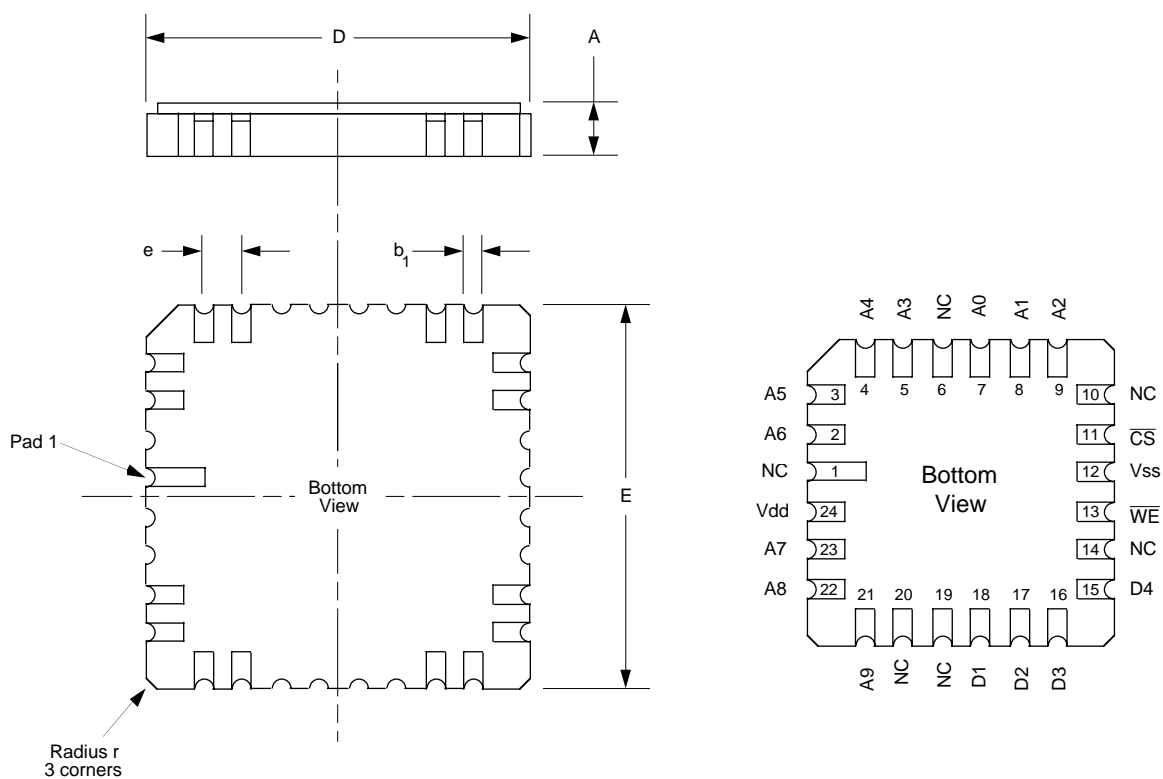

Figure 14: 24-Lead Ceramic Flatpack (Solder Seal) - Package Style F





Ref	Millimetres			Inches		
	Min.	Nom.	Max.	Min.	Nom.	Max.
A	-	-	2.16	-	-	0.096
b1	-	0.51	-	-	0.020	-
D	8.76	-	9.14	0.345	-	0.360
E	8.76	-	9.14	0.345	-	0.360
e	-	1.02	-	-	0.040	-
r	-	0.19	-	-	0.0075	-

XG470

Figure 15: 24-Pad Leadless Chip Carrier - Package Style L

# MA5114

Function	Package Option			Via	Burnin			Radiation
	F	C	L		Static 1	Static 2	Dynamic	
A6	2	1	2	R	0V	5V	F6	5V
A5	3	2	3	R	0V	5V	F5	5V
A4	4	3	4	R	0V	5V	F4	5V
A3	5	4	5	R	0V	5V	F3	5V
A0	7	5	7	R	0V	5V	F0	5V
A1	8	6	8	R	0V	5V	F1	5V
A2	9	7	9	R	0V	5V	F2	5V
NCS	11	8	11	R	0V	5V	0V	5V
VSS	12	9	12	Direct	0V	0V	0V	0V
NWE	13	10	13	R	0V	5V	5V	5V
D4	15	11	15	R	0V	5V	LOAD	5V
D3	16	12	16	R	0V	5V	LOAD	5V
D2	17	13	17	R	0V	5V	LOAD	5V
D1	18	14	18	R	0V	5V	LOAD	5V
A9	21	15	21	R	0V	5V	F9	5V
A8	22	16	22	R	0V	5V	F8	5V
A7	23	17	23	R	0V	5V	F7	5V
VDD	24	18	24	Direct	5V	5V	5V	5V

1. F0=150KHz, F1=F0/2, F2=F0/4, F3=F0/8 etc.

2. Burnin R=1k

3. Radiation R=10k

Figure 16: Burnin and Radiation Configuration

**RADIATION TOLERANCE**

**Total Dose Radiation Testing**

For product procured to guaranteed total dose radiation levels, each wafer lot will be approved when all sample devices from each lot pass the total dose radiation test.

The sample devices will be subjected to the total dose radiation level (Cobalt-60 Source), defined by the ordering code, and must continue to meet the electrical parameters specified in the data sheet. Electrical tests, pre and post irradiation, will be read and recorded.

GEC Plessey Semiconductors can provide radiation testing compliant with MIL-STD-883 test method 1019, Ionizing Radiation (Total Dose).

Total Dose (Function to specification)*	1x10 <sup>5</sup> Rad(Si)
Transient Upset (Stored data loss)	5x10 <sup>10</sup> Rad(Si)/sec
Transient Upset (Survivability)	>1x10 <sup>12</sup> Rad(Si)/sec
Neutron Hardness (Function to specification)	>1x10 <sup>15</sup> n/cm <sup>2</sup>
Single Event Upset**	3.4x10 <sup>-9</sup> Errors/bit day
Latch Up	Not possible

\* Other total dose radiation levels available on request

\*\* Worst case galactic cosmic ray upset - interplanetary/high altitude orbit

Figure 17: Radiation Hardness Parameters

**SINGLE EVENT UPSET CHARACTERISTICS**

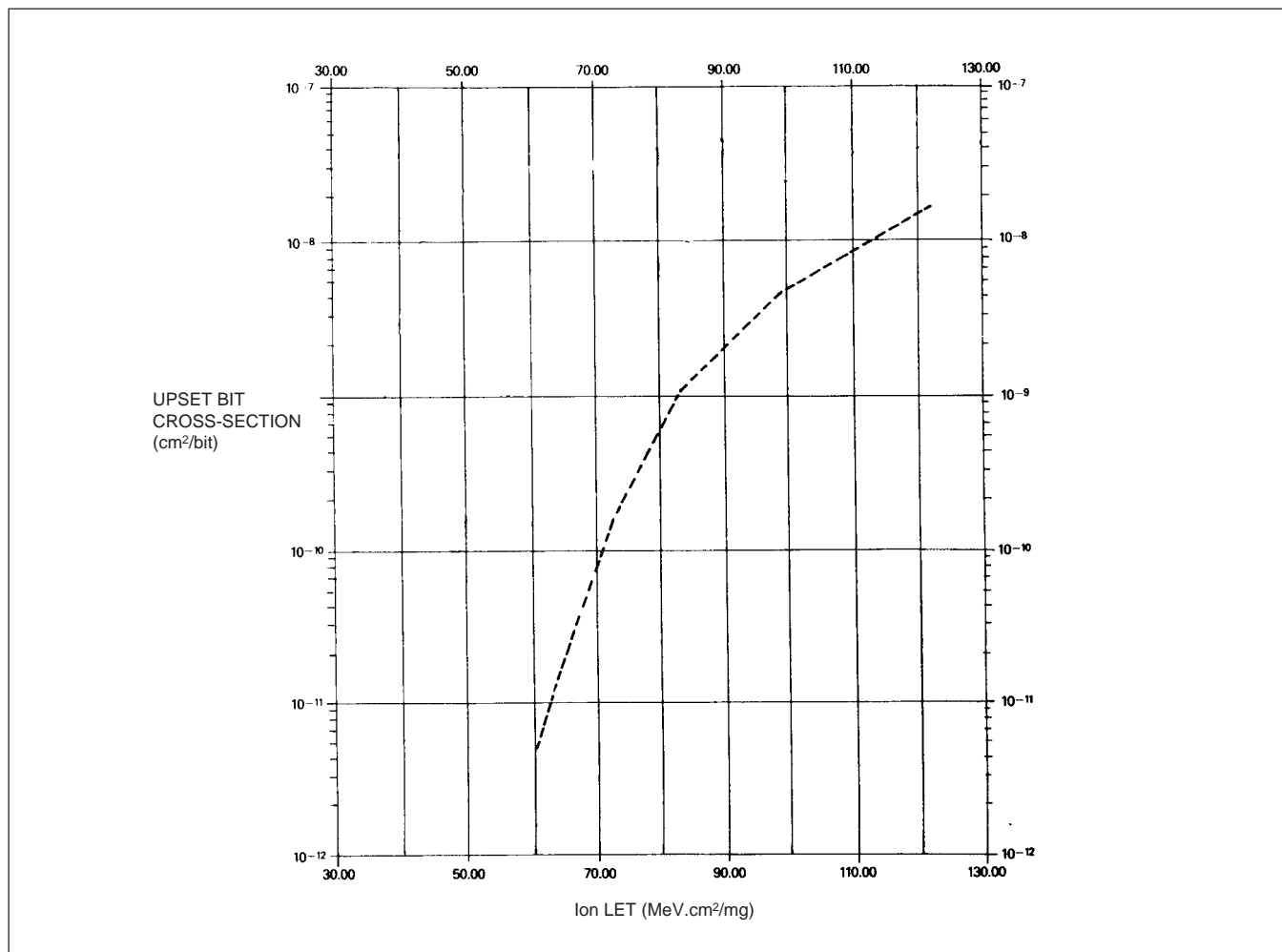
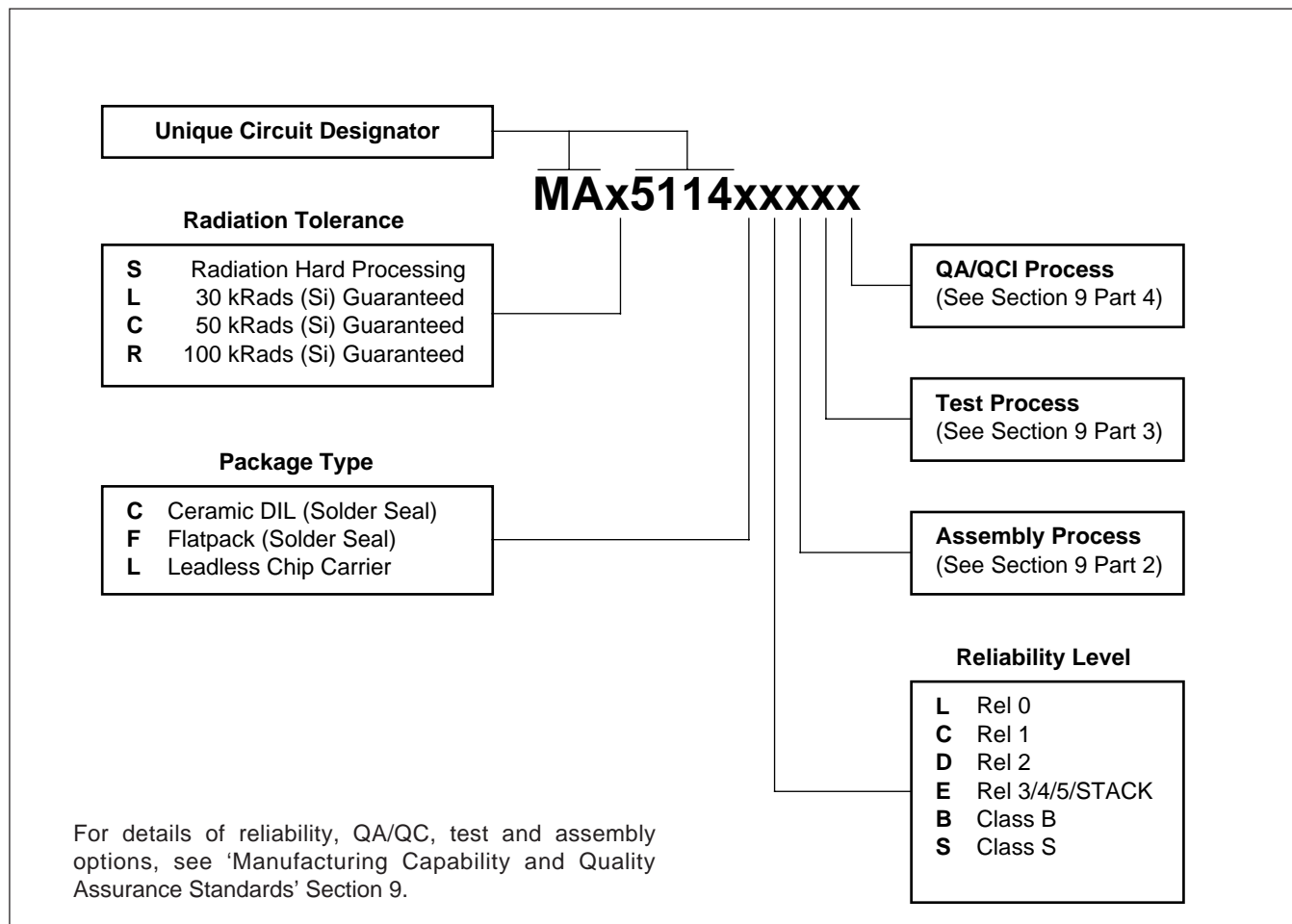

Figure 18: Typical Per-Bit Upset Cross-Section vs Ion LET

ORDERING INFORMATION



<http://www.dynexsemi.com>

e-mail: [power\\_solutions@dynexsemi.com](mailto:power_solutions@dynexsemi.com)

**HEADQUARTERS OPERATIONS**  
**DYNEX SEMICONDUCTOR LTD**  
 Doddington Road, Lincoln.  
 Lincolnshire. LN6 3LF. United Kingdom.  
 Tel: 00-44-(0)1522-500500  
 Fax: 00-44-(0)1522-500550

**DYNEX POWER INC.**  
 Unit 7 - 58 Antares Drive,  
 Nepean, Ontario, Canada K2E 7W6.  
 Tel: 613.723.7035  
 Fax: 613.723.1518  
 Toll Free: 1.888.33.DYNEX (39639)

**CUSTOMER SERVICE CENTRES**  
**France, Benelux, Italy and Spain** Tel: +33 (0)1 69 18 90 00. Fax: +33 (0)1 64 46 54 50  
**North America** Tel: 011-800-5554-5554. Fax: 011-800-5444-5444  
**UK, Germany, Scandinavia & Rest Of World** Tel: +44 (0)1522 500500. Fax: +44 (0)1522 500020

**SALES OFFICES**  
**France, Benelux, Italy and Spain** Tel: +33 (0)1 69 18 90 00. Fax: +33 (0)1 64 46 54 50  
**Germany** Tel: 07351 827723  
**North America** Tel: (613) 723-7035. Fax: (613) 723-1518. Toll Free: 1.888.33.DYNEX (39639) /  
 Tel: (831) 440-1988. Fax: (831) 440-1989 / Tel: (949) 733-3005. Fax: (949) 733-2986.  
**UK, Germany, Scandinavia & Rest Of World** Tel: +44 (0)1522 500500. Fax: +44 (0)1522 500020  
 These offices are supported by Representatives and Distributors in many countries world-wide.  
 © Dynex Semiconductor 2000 Publication No. DS3581-5 Issue No. 5.0 January 2000  
 TECHNICAL DOCUMENTATION – NOT FOR RESALE. PRINTED IN UNITED KINGDOM

**Datasheet Annotations:**

Dynex Semiconductor annotate datasheets in the top right hand corner of the front page, to indicate product status. The annotations are as follows:-

**Target Information:** This is the most tentative form of information and represents a very preliminary specification. No actual design work on the product has been started.

**Preliminary Information:** The product is in design and development. The datasheet represents the product as it is understood but details may change.

**Advance Information:** The product design is complete and final characterisation for volume production is well in hand.

**No Annotation:** The product parameters are fixed and the product is available to datasheet specification.

This publication is issued to provide information only which (unless agreed by the Company in writing) may not be used, applied or reproduced for any purpose nor form part of any order or contract nor to be regarded as a representation relating to the products or services concerned. No warranty or guarantee express or implied is made regarding the capability, performance or suitability of any product or service. The Company reserves the right to alter without prior notice the specification, design or price of any product or service. Information concerning possible methods of use is provided as a guide only and does not constitute any guarantee that such methods of use will be satisfactory in a specific piece of equipment. It is the user's responsibility to fully determine the performance and suitability of any equipment using such information and to ensure that any publication or data used is up to date and has not been superseded. These products are not suitable for use in any medical products whose failure to perform may result in significant injury or death to the user. All products and materials are sold and services provided subject to the Company's conditions of sale, which are available on request.

All brand names and product names used in this publication are trademarks, registered trademarks or trade names of their respective owners.