

Version : 1.1

<p style="text-align: center;">TECHNICAL SPECIFICATION</p> <p style="text-align: center;">MODEL NO. : PW036XS3</p>
--

Customer's Confirmation

Customer _____

Date _____

By _____

PVI's Confirmation

Confirmed By _____

Prepared By _____

FOR MORE INFORMATION:
AZ DISPLAYS, INC.
75 COLUMBIA, ALISO VIEJO, CA, 92656
[Http://www.AZDISPLAYS.com](http://www.AZDISPLAYS.com)

Date : Jan. 10 , 2005

This technical specification is subject to change without notice.
Please return 1 copy with your signature on this page for approval.

TECHNICAL SPECIFICATION***CONTENTS***

<i>NO.</i>	<i>ITEM</i>	<i>PAGE</i>
-	Cover	1
-	Contents	2
1	Application	3
2	Features	3
3	Mechanical Specifications	3
4	Mechanical Drawing of TFT-LCD module	4
5	Input / Output Terminals	5
6	Pixel Arrangement and Input Connector Pin No.	6
7	Absolute Maximum Ratings	7
8	Electrical Characteristics	7
9	Power On Sequence	17
10	Optical Characteristics	17
11	Handling Cautions	20
12	Reliability Test	21
13	Block Diagram	22
14	Packing	23
-	Revision History	25
	Appendix	26

1. Application

This technical specification applies to 3.6” color TFT-LCD module , PW036XS3.

The applications of the panel are car TV, portable DVD, GPS, multimedia applications and other AV systems..

2. Features

- . Amorphous silicon TFT-LCD panel with LED Backlight unit.
- . Compatible with NTSC & PAL system
- . Pixel in stripe configuration
- . Slim and compact
- . Image Reversion : Up/Down and Left/Right
- . Support Multi Video Display Mode
(With PVI timing controller : PVI-1004C)

3. Mechanical Specifications

Parameter	Specifications	Unit
Screen Size	3.6 (16:9 diagonal)	inch
Display Format	960×234	dot
Active Area	78.24(H)× 45.864(V)	mm
Dot Pitch	0.0815 (H)×0.196 (V)	mm
Pixel Configuration	Stripe	
Outline Dimension	89.47(W) × 58.09(H) × 3.6(D)(typ.)	mm
Surface Treatment	Anti – Glare	
Weight	40±5	g

4. Mechanical Drawing of TFT-LCD Module

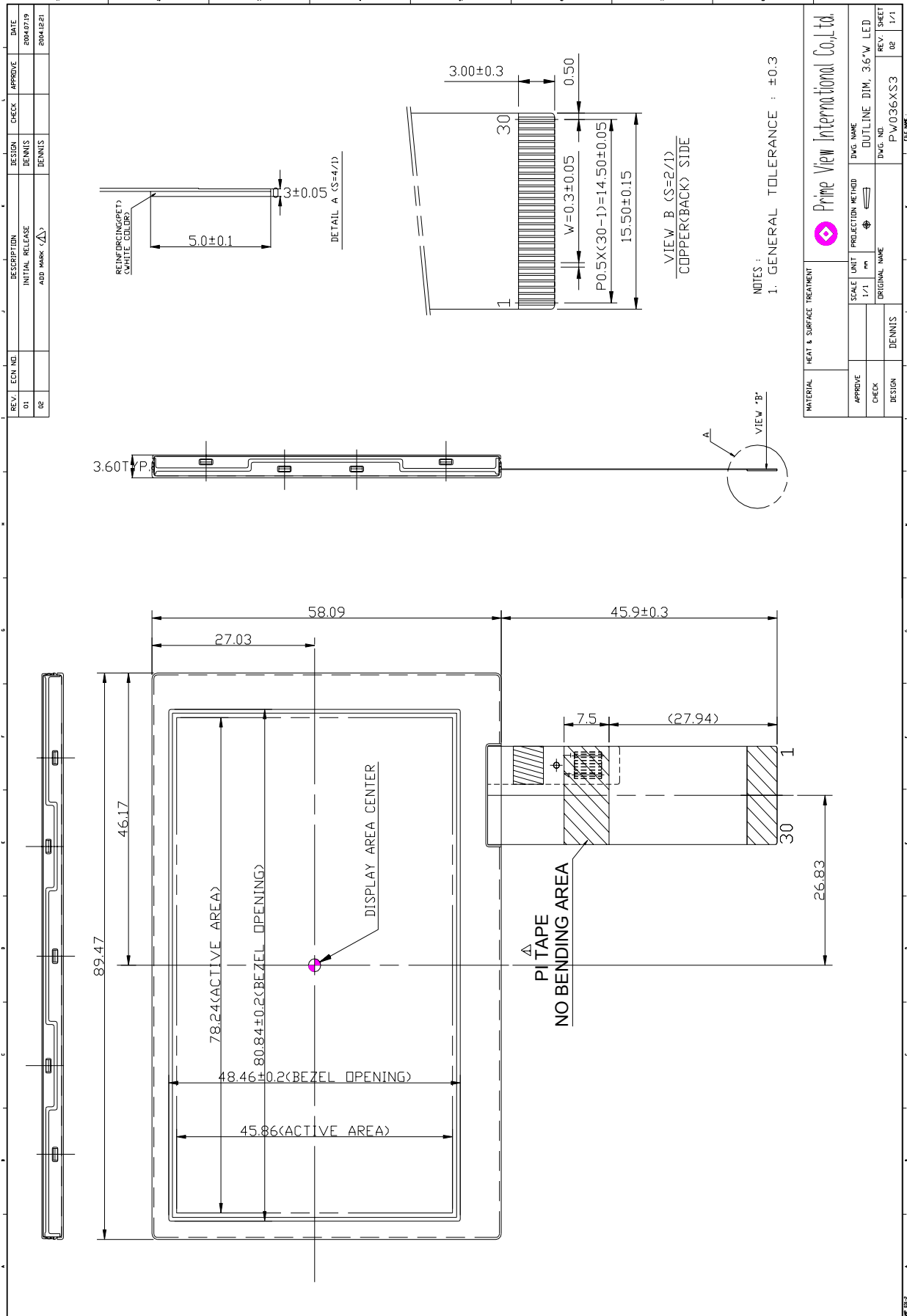

5. Input / Output Terminals

TFT-LCD Module Connector

FPC Down Connect , 30Pins , Pitch : 0.5 mm

Pin No	Symbol	I/O	Description	Remark
1	GLED1	I	Ground for LED backlight	
2	VLED1	I	Supply voltage of LED backlight	Note 5-8
3	GLED2	I	Ground for LED backlight	
4	VLED2	I	Supply voltage of LED backlight	Note 5-8
5	GND	-	Ground for logic circuit	
6	V _{CC}	I	Supply voltage of logic control circuit for gate driver	Note 5-3
7	V _{EE}	I	Negative power for gate driver	Note 5-4
8	V _{GH}	I	Positive power for gate driver	Note 5-5
9	STVD	I/O	Vertical start pulse	Note 5-1
10	STVU	I/O	Vertical start pulse	
11	CKV	I	Shift clock for gate driver	
12	U/D	I	Up / Down control for gate driver	Note 5-1
13	OE3	I	Output enable for gate driver	
14	OE2	I	Output enable for gate driver	
15	OE1	I	Output enable for gate driver	
16	V _{COM}	I	Common electrode voltage	
17	STHL	I/O	Start pulse for source driver	Note 5-2
18	V _{SS2}	-	Ground for analog circuit	
19	V _R	I	Video Input R	
20	V _G	I	Video Input G	
21	V _B	I	Video Input B	
22	V _{SS1}	-	Ground for digital circuit	
23	V _{DD2}	I	Supply power of analog circuit	Note 5-6
24	CPH1	I	Sampling and shift clock for source driver	
25	CPH2	I	Sampling and shift clock for source driver	
26	CPH3	I	Sampling and shift clock for source driver	
27	V _{DD1}	I	Supply power for digital circuit	Note 5-7
28	R/L	I	Left / Right control for source driver	Note 5-2
29	OEH	I	Output enable for source driver	
30	STHR	I/O	Start pulse for source driver	Note 5-2

Note 5-1

U/D	STVD	STVU	scanning direction
V _{CC}	Input	output	down to up
GND	Output	input	up to down

Note 5-2

R/L	STHL	STHR	scanning direction
V _{CC}	output	input	left to right
GND	input	output	right to left

The definitions of Note 5-1,5-2

U/D(PIN 12)=Low R/L(PIN 28)=High

U/D(PIN 12)=High R/L(PIN 28)=Low

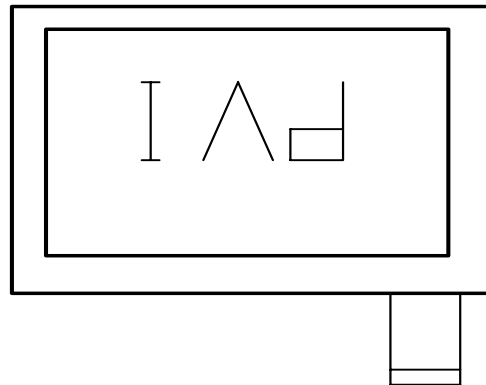
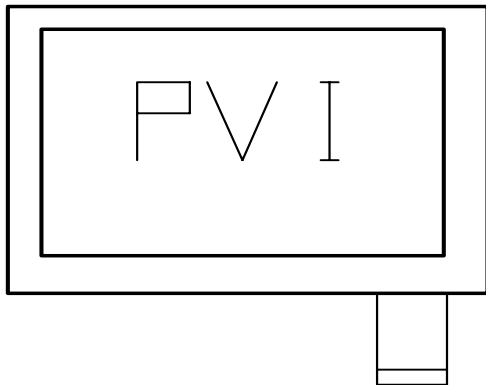

Note 5-3 : V_{CC} TYP. = +3.3V

Note 5-4 : V_{EE} TYP. = -12V

Note 5-5 : V_{GH} TYP. = +17V

Note 5-6 : V_{DD2} TYP. = +5V

Note 5-7 : V_{DD1} TYP. = +3.3V

Note 5-8 : I_{LED1} , I_{LED2} TYP.=20mA

6. Pixel Arrangement and Input Connector Pin NO.

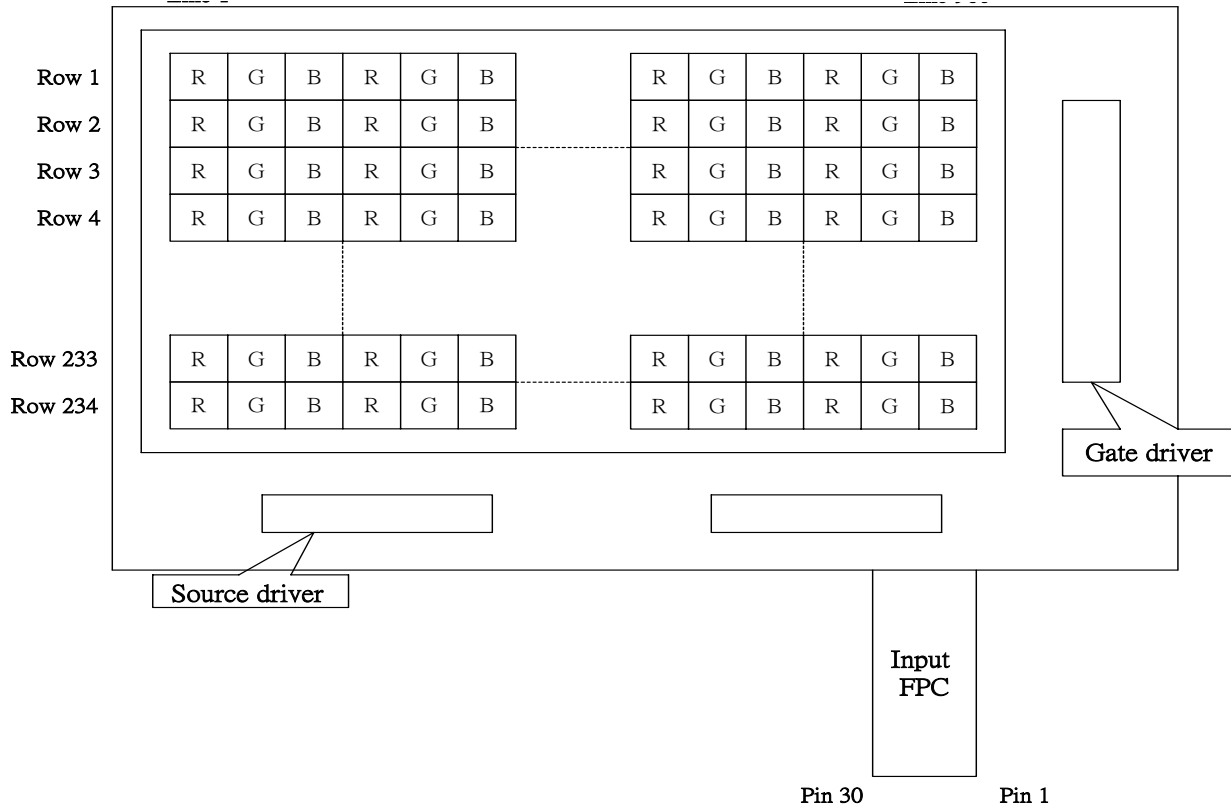

7. Absolute Maximum Ratings :

The followings are maximum values , which if exceeded, may cause faulty operation or damage to the unit.

GND = 0 V , Ta = 25 °C

Parameter	Symbol	MIN.	MAX.	Unit	Remark
Supply Voltage For Source Driver	V _{DD2}	-0.3	+5.8	V	
	V _{DD1}	-0.3	+7.0	V	
Supply Voltage For Gate Driver	V _{CC}	-0.3	+6.0	V	
	V _{GH} -V _{EE}	-0.3	+40.0	V	
	H Level V _{GH}	-0.3	+25.0	V	
	L Level V _{EE}	-16	+0.3	V	
Analog Signal Input Level	V _R ,V _G ,V _B	-0.2	V _{DD1} +0.2	V	Note 7-1
Storage Temperature		-10	+70	°C	
Operation Temperature		0	+60	°C	Note 7-2

Notes 7-1 : Analog Input Voltage means V_R,V_G,V_B.

Notes 7-2 : Operating Temperature define that contrast, response time, other display optical character are Ta=+25°C.

8. Electrical Characteristics
8-1) Operating Condition

Parameter		Symbol	MIN.	Typ.	MAX.	Unit	Remark
Supply Voltage For Source Driver	Analog	V _{DD2}	+4.5	+5.0	+5.5	V	
	Logic	V _{DD1}	+3.0	+3.3	+3.6	V	
Supply Voltage For Gate Driver	H level	V _{GH}	+15	+17	+19	V	
	L level	V _{EE DC}	-13	-12	-10.5	V	DC Component of V _{EE}
		V _{EE AC}		+6.0		V _{P-P}	AC Component of V _{EE}
	Logic	V _{CC}	+3.0	+3.3	+3.6	V	Note8-1
Analog Signal input Level (V _R , V _G , V _B)	V _{IAC}			+4.0	+4.2	V	AC Component Note8-3
	V _{IDC}			2.5		V	DC Component Note8-3
Digital input voltage	H level	V _{IH}	0.7 V _{DD1}	-	V _{DD1}	V	
	L level	V _{IL}	-0.3	-	0.3 V _{DD1}	V	
Digital output voltage	H level	V _{OH}	0.7 V _{DD1}	-	V _{DD1}	V	
	L level	V _{OL}	-0.3	-	0.3 V _{DD1}	V	
V _{COM}		V _{COM AC}	-	+6.0	-	V _{P-P}	AC Component of V _{COM}
		V _{COM DC}	-	1.2	-	V	DC Component of V _{COM} Note 8-2

Note 8-1 :The typical value of Logic circuit supply power V_{CC} & V_{DD1} is 3.3 ± 0.3V , if customer choice 5.0 ± 0.5V , the panel power consumption will increase about 10mW .

Note 8-2 :PVI strongly suggests that the V_{COM DC} level shall be adjustable , and the adjustable level range is 1.2V±1V , every module's V_{COM DC} level shall be carefully adjusted to show a best image performance.

Note 8-3: Both NTSC and PAL system Video Signal input waveform is based on 8 steps gray scale.

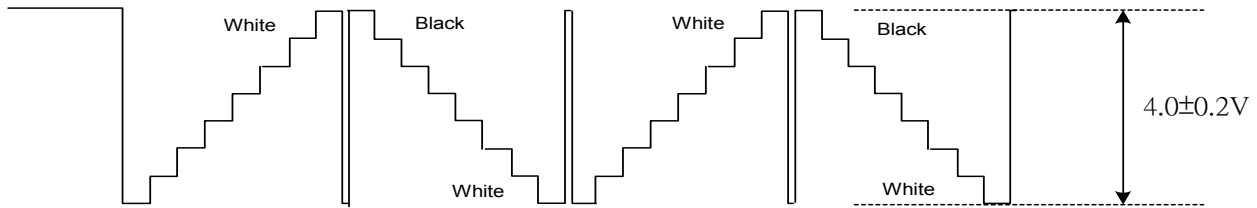

8-2) Recommended driving condition for LED backlight

GND = 0 V , Ta = 25 °C

Parameter	Symbol	Min	TYP	MAX	Unit	Remark
Supply voltage of LED backlight	VLED1	9	9.6	11.4	V	I _L = 20 mA
	VLED2					
Supply current of LED backlight	ILED1		20		mA	Note 8-4
	ILED2					
Backlight Power Consumption	PLED	360	384	456	mW	Note 8-5

Note 8-4 : LED B/L applied information , please refer to the appendix at the end .

Note 8-5 : PLED = VLED1* ILED1 + VLED2* ILED2 .



8-3) Power Consumption

Parameter	Symbol	Conditions	TYP.	MAX	Unit	Remark
Supply current for Gate Driver (Hi level)	I _{GH}	V _{GH} = +17V	0.08	0.12	mA	
Supply current for Gate Driver (Low level)	I _{EE}	V _{EE} = -12V	0.3	0.45	mA	V _{EE} center voltage
Supply current for Source Driver(Digital)	I _{DD1}	V _{DD1} = +3.3V	1.2	3.0	mA	
Supply current for Source Driver(Analog)	I _{DD2}	V _{DD2} = +5V	7.0	10.0	mA	
Supply current for Gate Driver (Digital)	I _{CC}	V _{CC} = +3.3V	0.005	0.008	mA	
LCD Panel Power Consumption			44.3	68.3	mW	
Backlight Power Consumption	PLED		384	456	mW	
Total Power Consumption			428.3	524.3	mW	

8-4) Timing Characteristics Of Input Signals

Characteristics	Symbol	Min.	Typ.	Max.	Unit	Remark
Rising time	t_r	-	-	10	ns	
Falling time	t_f	-	-	10	ns	
High and low level pulse width	t_{CPH}	147	156	166	ns	CPH1~CPH3
CPH pulse duty	t_{CWH}	30	50	70	%	CPH1~CPH3
STH setup time	t_{SUH}	20	-	-	ns	STHR,STHL
STH hold time	t_{HDH}	20	-	-	ns	STHR,STHL
STH pulse width	t_{STH}	-	1	-	t_{CPH}	STHR,STHL
STH period	t_H	61.5	63.5	65.5	μ s	STHR,STHL
OEH pulse width	t_{OEH}	-	1.6	-	μ s	OEH
Sample and hold disable time	t_{DIS1}	-	4.4	-	μ s	
OEV pulse width	t_{OEV}	-	12	-	μ s	OEV
CKV pulse width	t_{CKV}	-	32	-	μ s	CKV
Clean enable time	t_{DIS2}	-	6	-	μ s	
Horizontal display timing range	t_{DH}	-	320	-	$t_{CPH}/3$	
STV setup time	t_{SUV}	400	-	-	ns	
STV hold time	t_{HDV}	400	-	-	ns	STVU,STVD
STV pulse width	t_{STV}	-	-	1	t_H	STVU,STVD
Horizontal lines per field	t_V	256	262	268	t_H	
Vertical display start	t_{SV}		3	-	t_H	
Vertical display timing range	t_{DV}		234	-	t_H	
VCOM rising time	t_{rCOM}		-	5	μ s	
VCOM falling time	t_{fCOM}		-	5	μ s	
VCOM delay time	t_{DCOM}		-	3	μ s	
RGB delay time	t_{DRGB}		-	1	μ s	

8-5) Signal Timing Waveforms

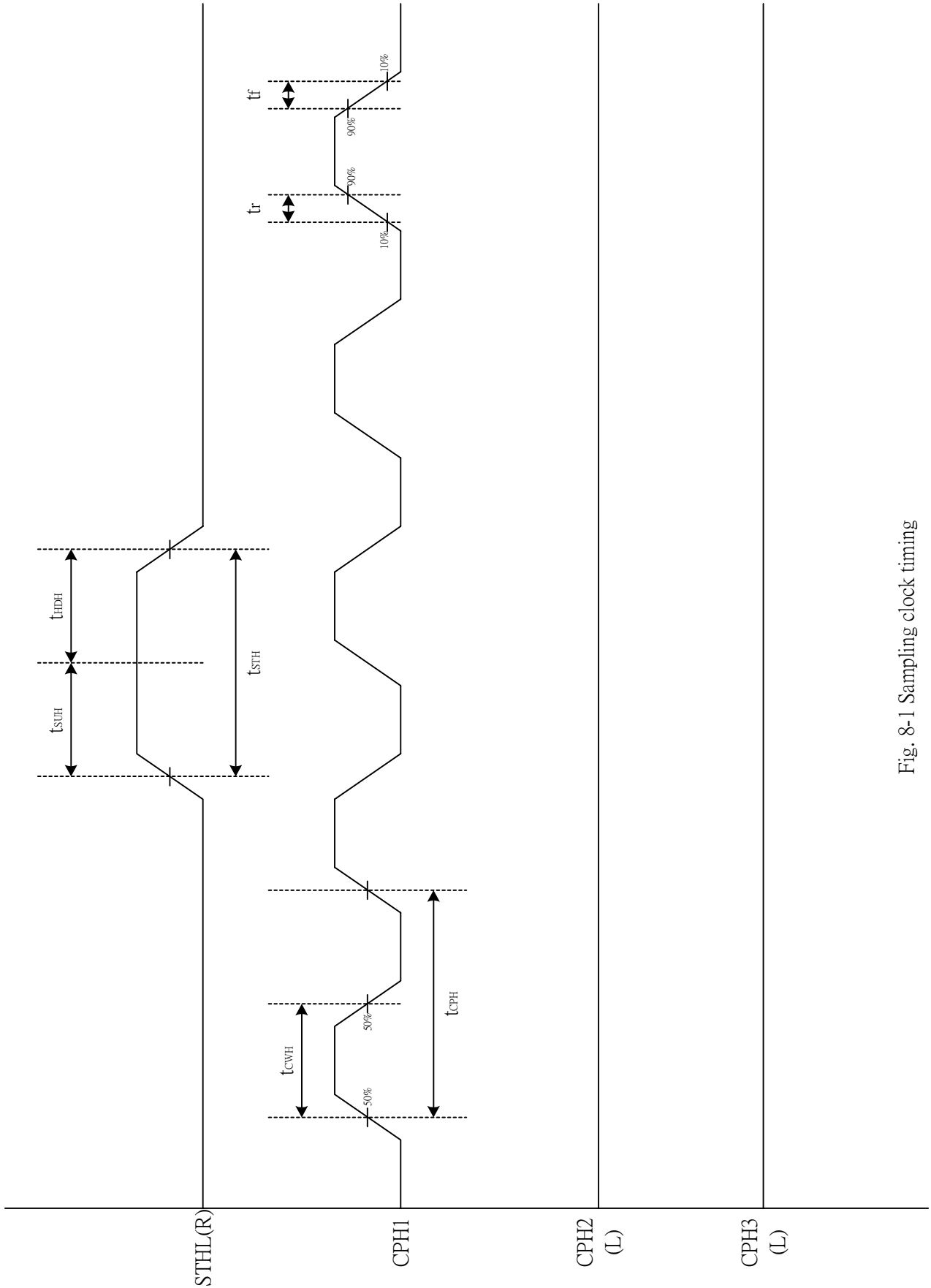

Fig. 8-1 Sampling clock timing

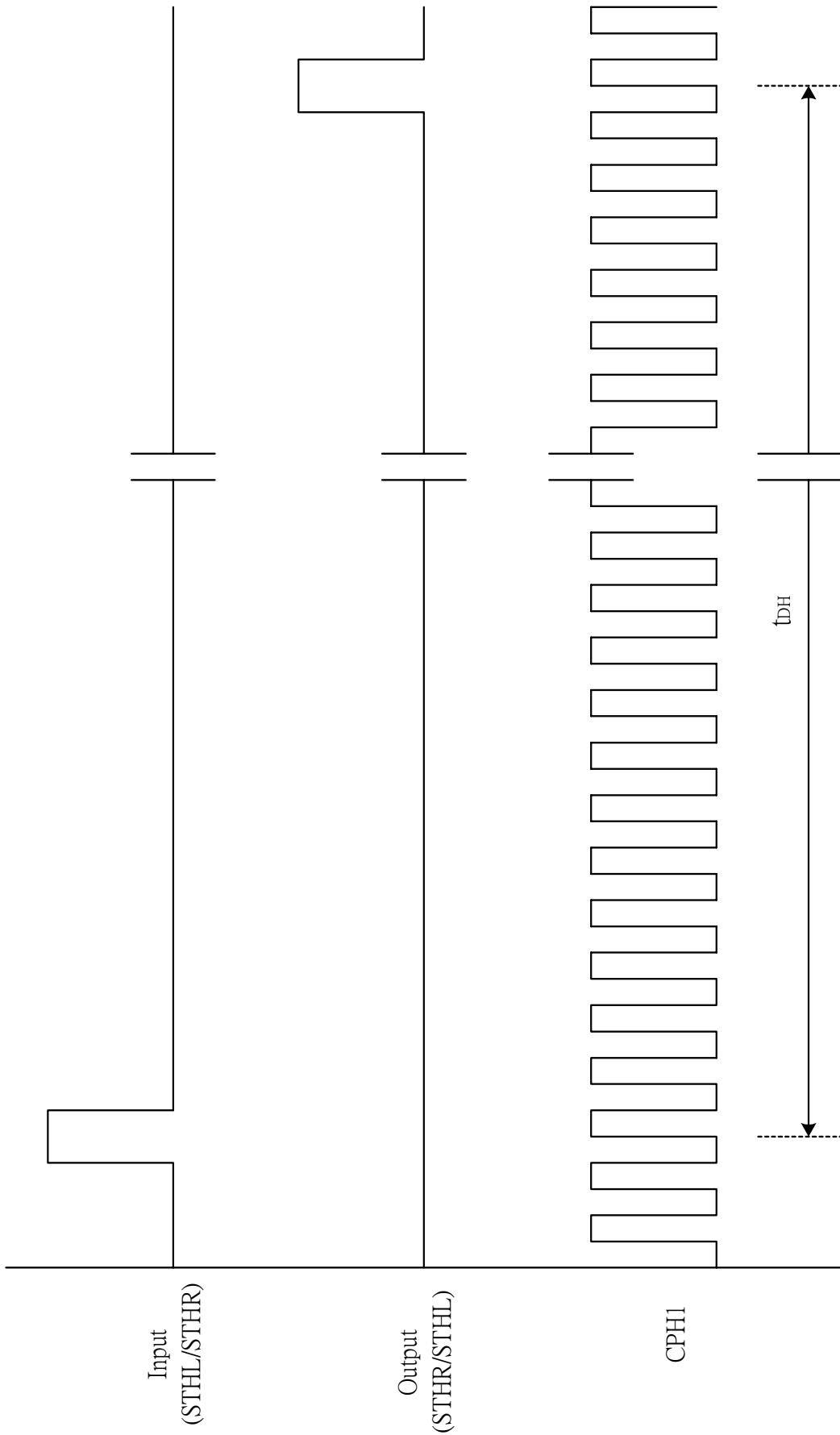

Fig. 8-2 Horizontal display timing range

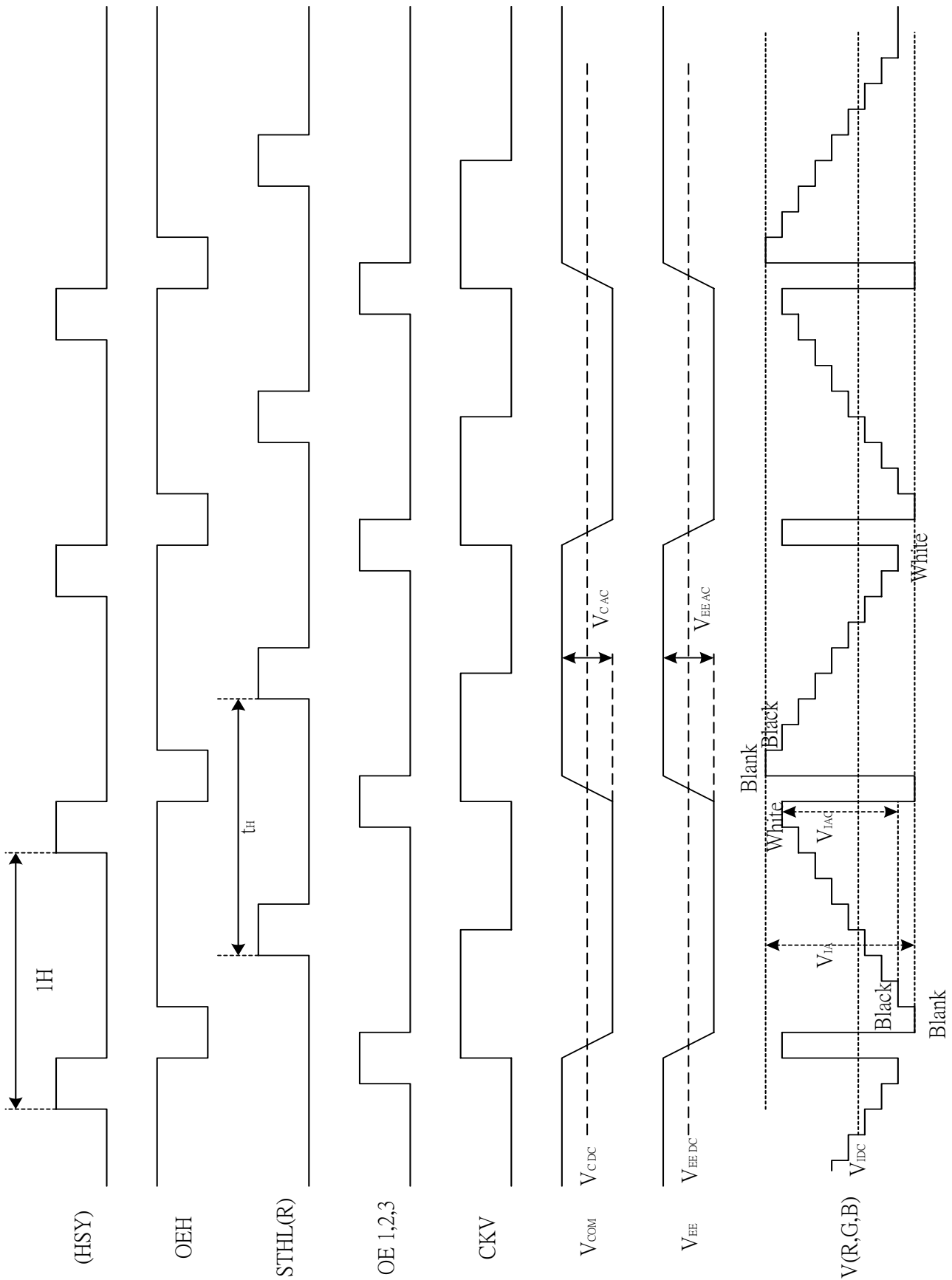
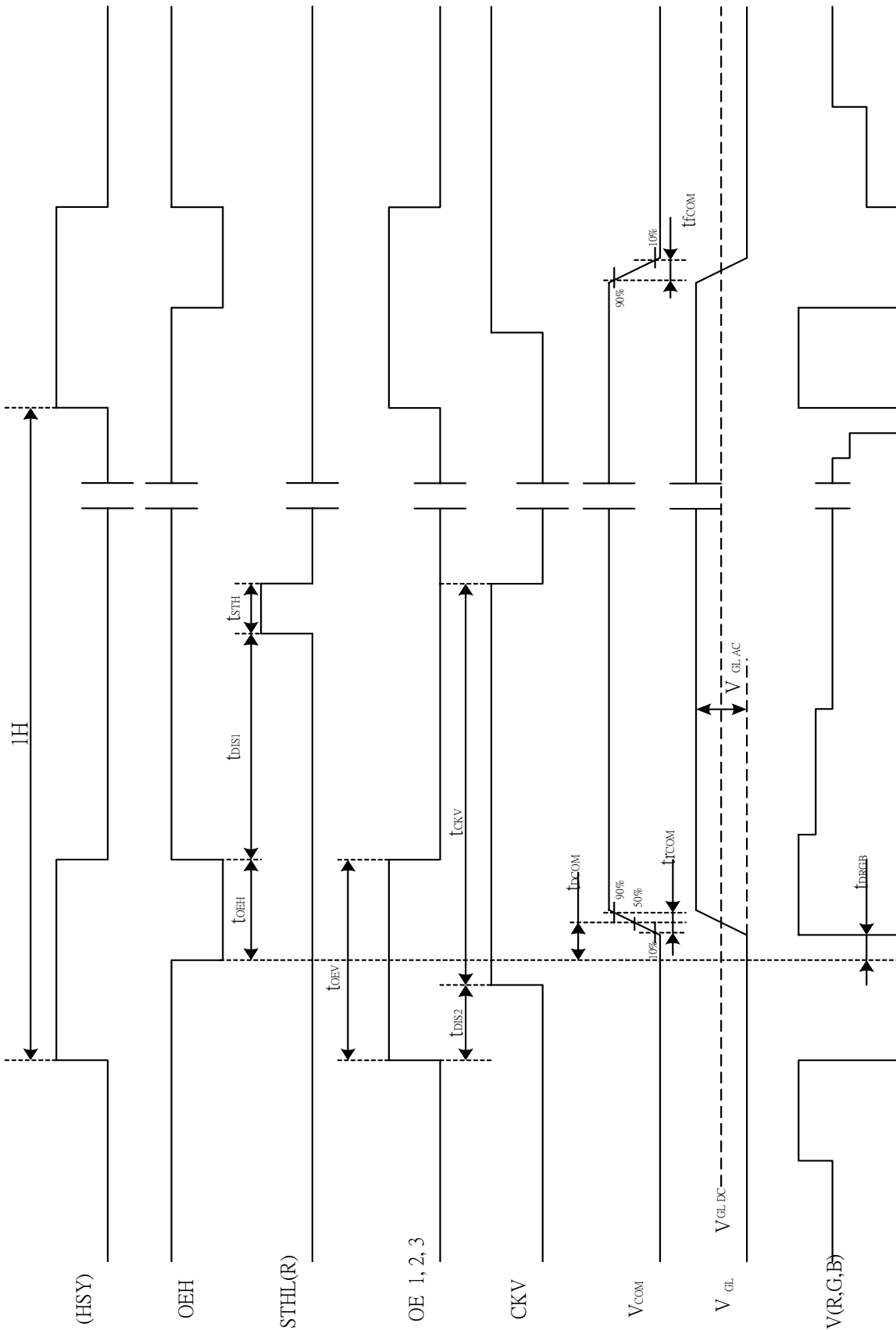

Fig. 8-3 (a) Horizontal timing



Note : The falling edge of OEV should be synchronized with the falling edge of OEH

Fig. 8-3 (b) Detail horizontal timing

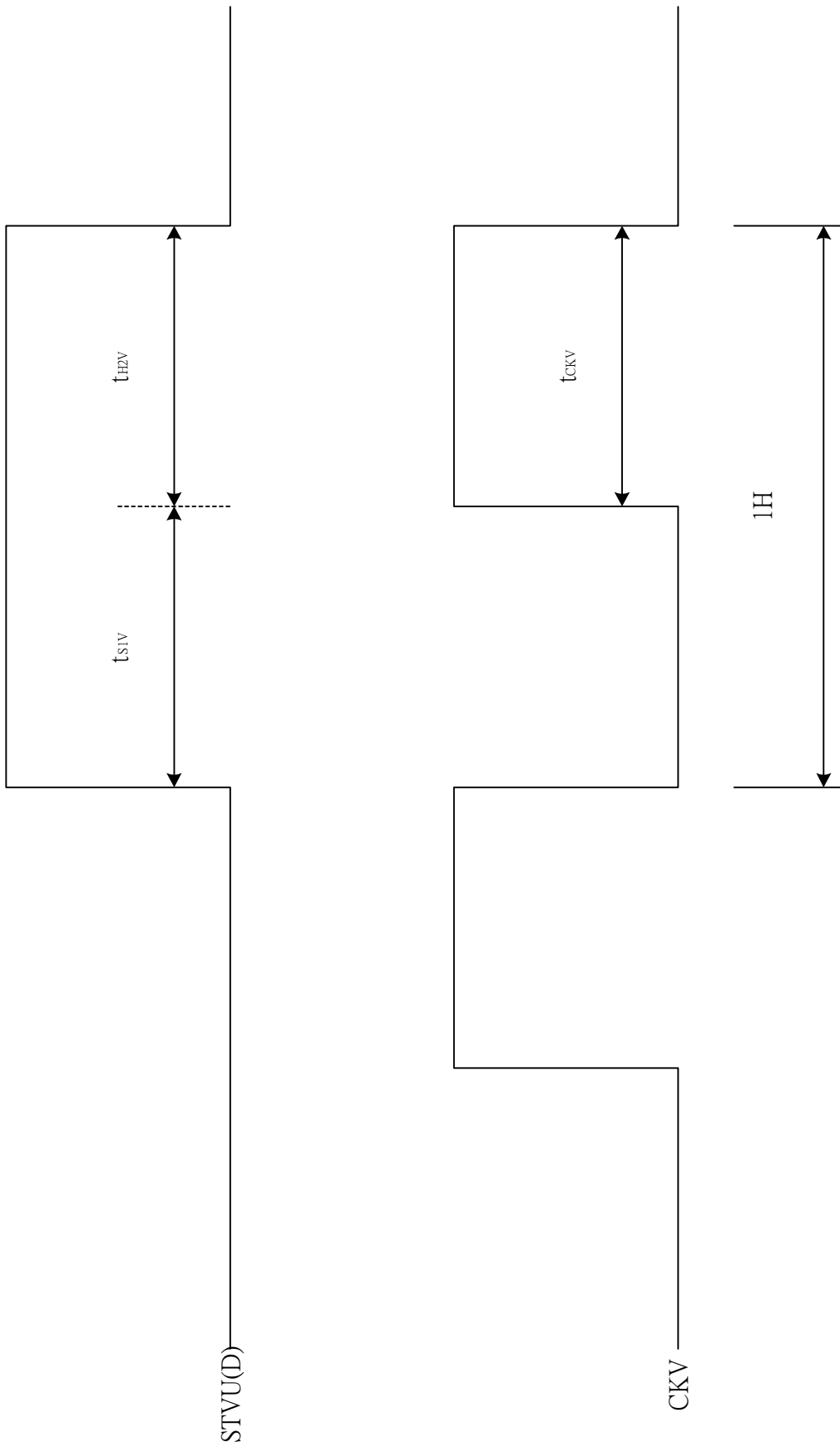

Fig. 8-4 Vertical shift clock timing

Vertical timing (From up to down)

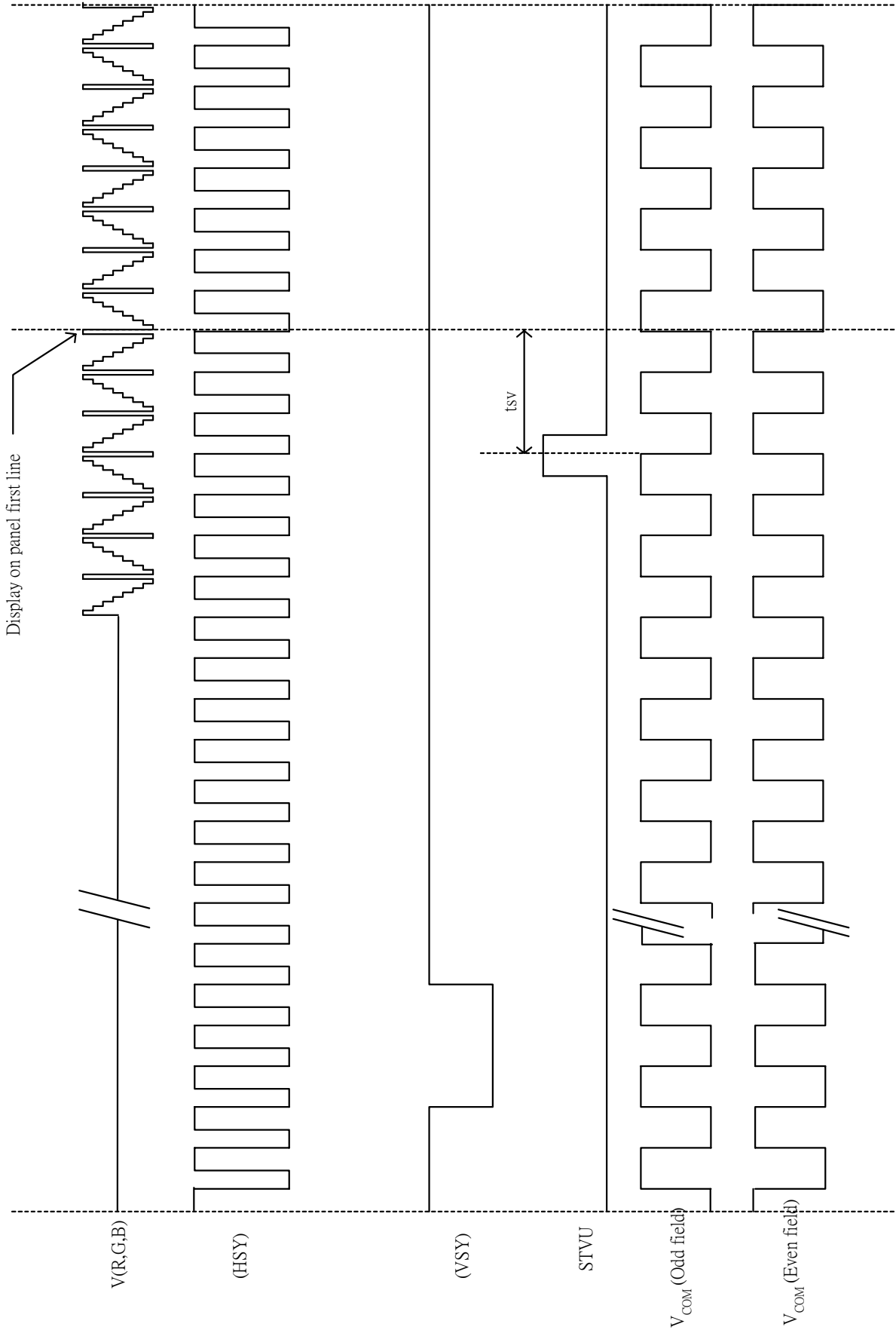

Fig. 8-5 (a) Vertical timing (From Up to Down)

Vertical timing (From down to up)

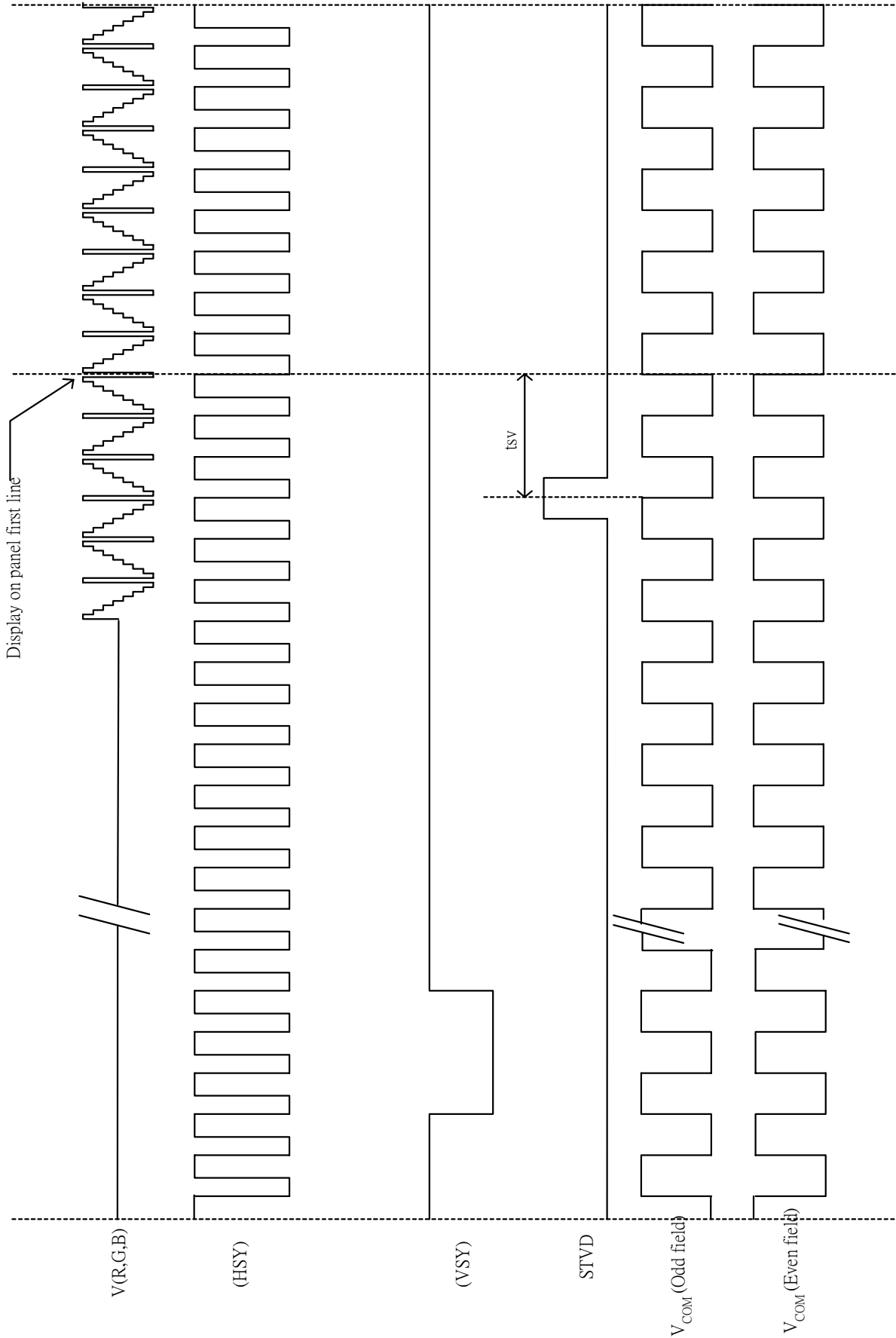
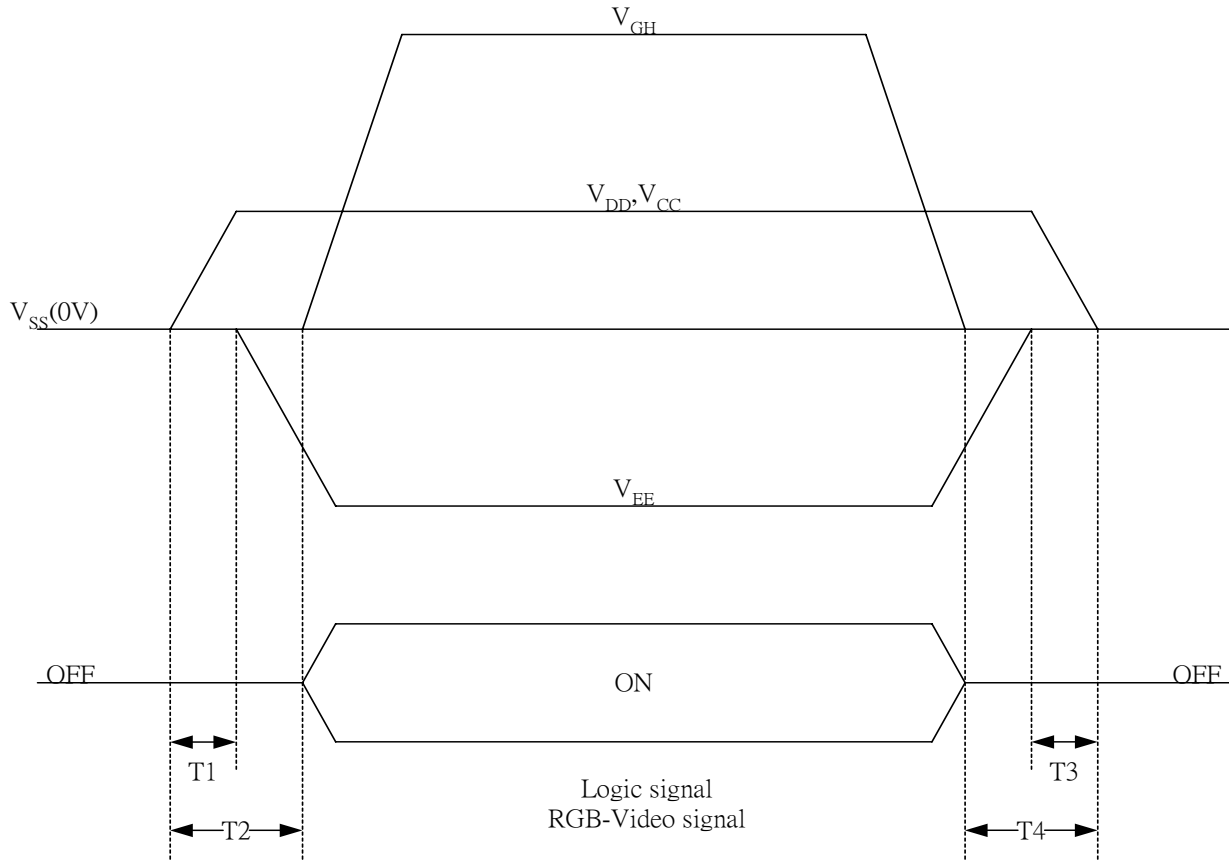

Fig. 8-5 (b) Vertical timing (From Down to Up)

9. Power On Sequence

The Power on Sequence only effect by V_{CC} , V_{SS} , V_{DD} , V_{EE} and V_{GH} , the others do not care.



- 1) $10ms \leq T1 < T2$
- 2) $0ms < T3 \leq T4 \leq 10ms$

10. Optical Characteristics

10-1) Specification:

$T_a = 25^\circ C$

Parameter	Symbol	Condition	MIN.	TYP.	MAX.	Unit	Remarks	
Viewing Angle	Horizontal	$\theta 21, \theta 22$	CR ≥ 10	45	55	---	deg	Note 10-1
	Vertical	$\theta 11$		30	35	---	deg	
		$\theta 12$		10	15	---	deg	
Contrast Ratio	CR	At optimized Viewing angle	200	350	---		Note 10-2	
Response time	Rise	Tr	$\theta = 0^\circ$	---	10	20	ms	Note 10-4
	Fall	Tf		---	25	50	ms	
Uniformity		U	70	80			Note 10-3	
Brightness			200	250		cd/m ²		
White Chromaticity	x	$\theta = 0^\circ$	0.27	0.30	0.33			
LED Backlight Life (+25°C)	y	$\theta = 0^\circ$	0.30	0.33	0.36		Note 10-5	
				10000		hrs		

Note 10-5 : Constant current 20mA for each loop , and the center brightness must more than 50% of initial brightness value .

Note 10-1 : The definitions of viewing angles

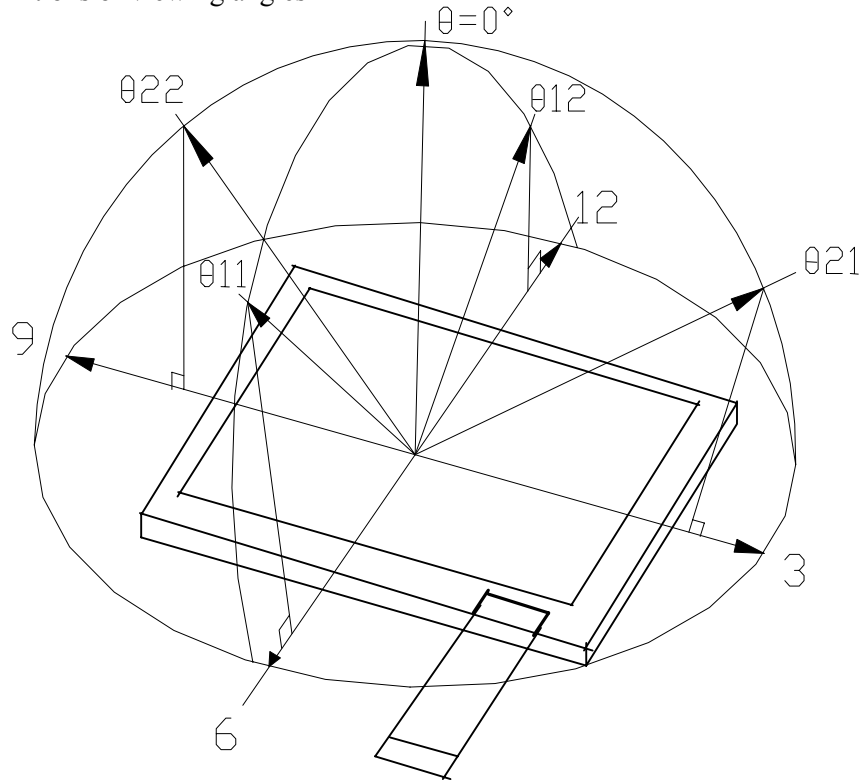

Note 10-2 : $CR = \frac{\text{Luminance when Testing point is White}}{\text{Luminance when Testing point is Black}}$

(Testing configuration see 10-2)

Contrast Ratio is measured in optimum common electrode voltage.

Note 10-3 : :1. Topcon BM-7(fast) luminance meter 1.0° field of view is used in the testing (after 10 minutes operation).

Note 10-4 : The definition of response time :

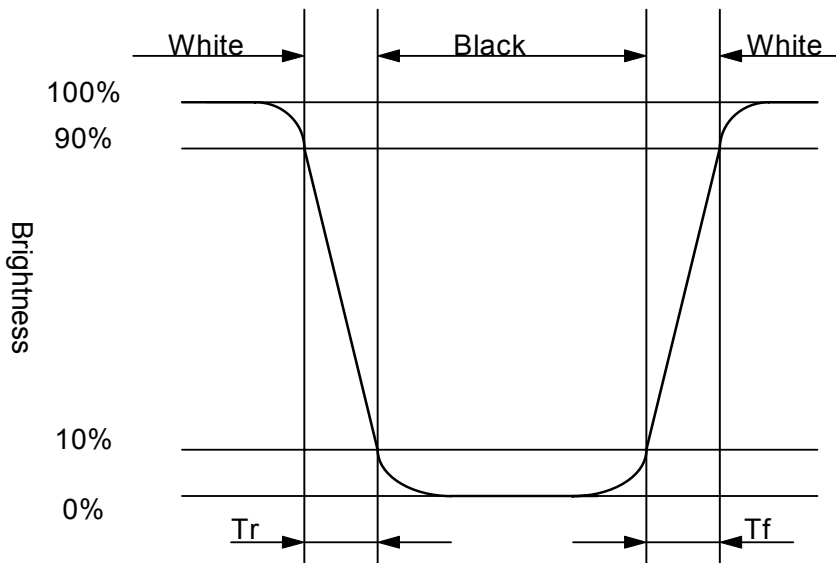

10-2) Testing configuration

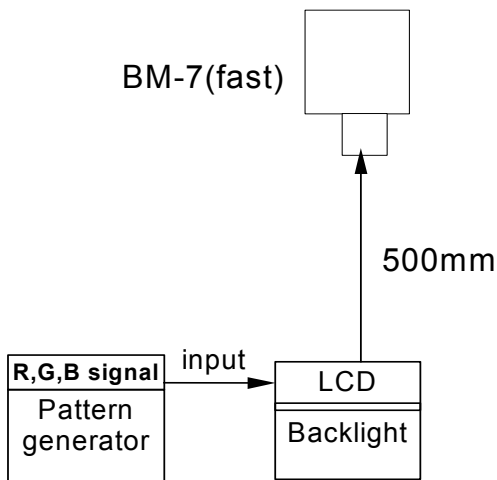

Caution: 1. Environmental illumination ≤ 1 lux
 2. Before test CR, Vcom voltage must be adjusted carefully to get the best CR.

- LCD Display

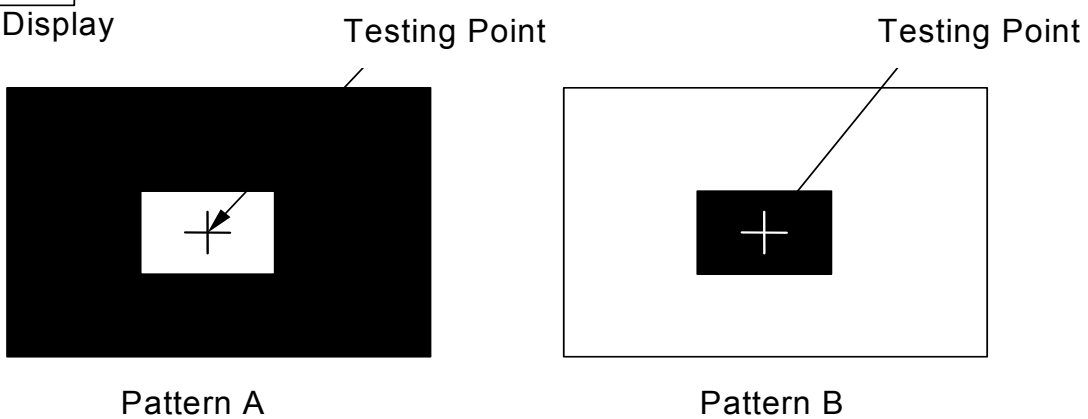

- R, G, B Waveform of Pattern A at Testing Point

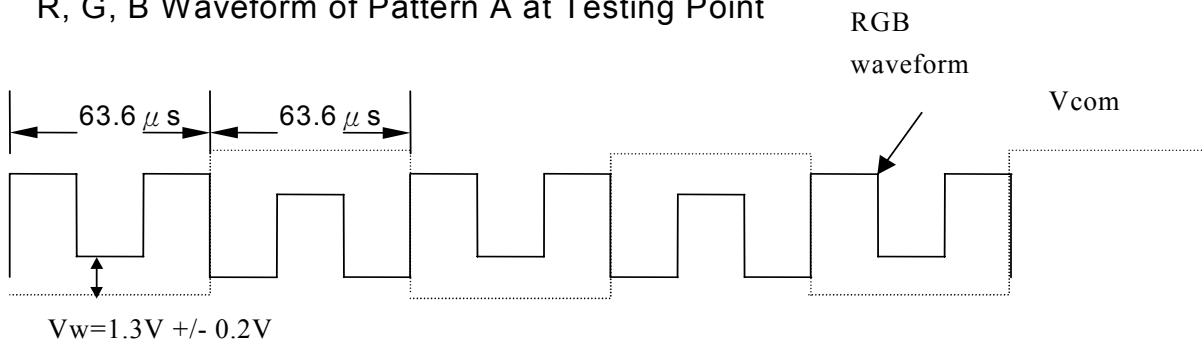

- R, G, B Waveform of Pattern B at Testing Point

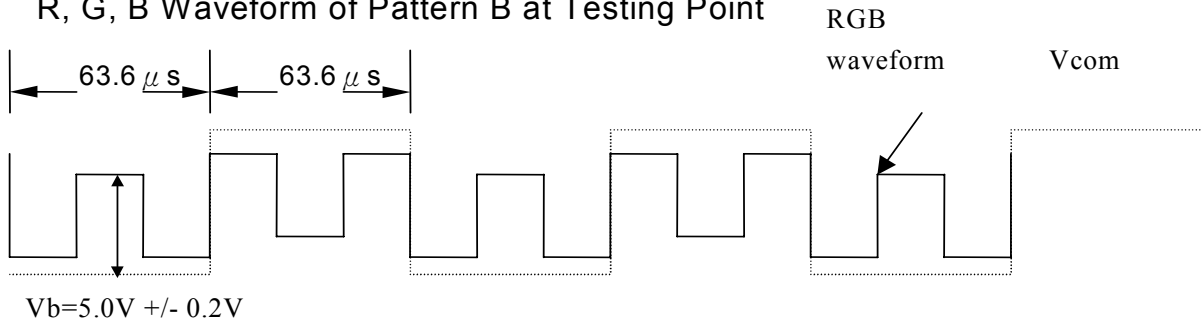

11. Handling Cautions

11-1) Mounting of module

- a) Please power off the module when you connect the input/output connector.
- b) Please connect the ground pattern of the inverter circuit surely. If the connection is not perfect, some following problems may happen possibly.
 1. The noise from the backlight unit will increase.
 2. The output from inverter circuit will be unstable.
 3. In some cases a part of module will heat.
- c) Polarizer which is made of soft material and susceptible to flaw must be handled carefully.
- d) Protective film (Laminator) is applied on surface to protect it against scratches and dirt. It is recommended to peel off the laminator before use and taking care of static electricity.

11-2) Precautions in mounting

- a) Wipe off water drops or finger grease immediately. Long contact with water may cause discoloration or spots.
- b) TFT-LCD module uses glass which breaks or cracks easily if dropped or bumped on hard surface. Please handle with care.
- c) Since CMOS LSI is used in the module. So take care of static electricity and earth yourself when handling.

11-3) Others

- a) Do not expose the module to direct sunlight or intensive ultraviolet rays for many hours.
- b) Store the module at a room temperature place.
- c) The voltage of beginning electric discharge may over the normal voltage because of leakage current from approach conductor by to draw lump read lead line around.
- d) If LCD panel breaks, it is possibly that the liquid crystal escapes from the panel. Avoid putting it into eyes or mouth. When liquid crystal sticks on hands, clothes or feet. Wash it out immediately with soap.
- e) Observe all other precautionary requirements in handling general electronic components.

12. Reliability Test

No	Test Item	Test Condition
1	High Temperature Storage Test	Ta = +70°C, 240 hrs
2	Low Temperature Storage Test	Ta = -10°C, 240 hrs
3	High Temperature Operation Test	Ta = +60°C, 240 hrs
4	Low Temperature Operation Test	Ta = 0°C, 240 hrs
5	High Temperature & High Humidity Operation Test	Ta = +50°C, 80%RH, 240 hrs
6	Thermal Cycling Test (non-operating)	-10°C ← → +70°C, 200 Cycles 30 min 30 min
7	Vibration test (non-operating)	Frequency : 10 ~ 55Hz Amplitude : 1mm, sweep time : 11 mins Test period : 6 cycles for each direction of X,Y, Z
8	Shock Test(non-operating)	100G, 6ms, 3cycles for each direction of X,Y,Z
9	Electrostatic Discharge Test (non-operating)	200pF, 0Ω Machine mode = ±200V 1 time / each terminal

Ta: ambient temperature

Note : The protective film must be removed before temperature test.

[Criteria]

Under the display quality test conditions with normal operation state, there should be no change which may affect practical display function.

13. Block Diagram

14.1 LCD Module Diagram

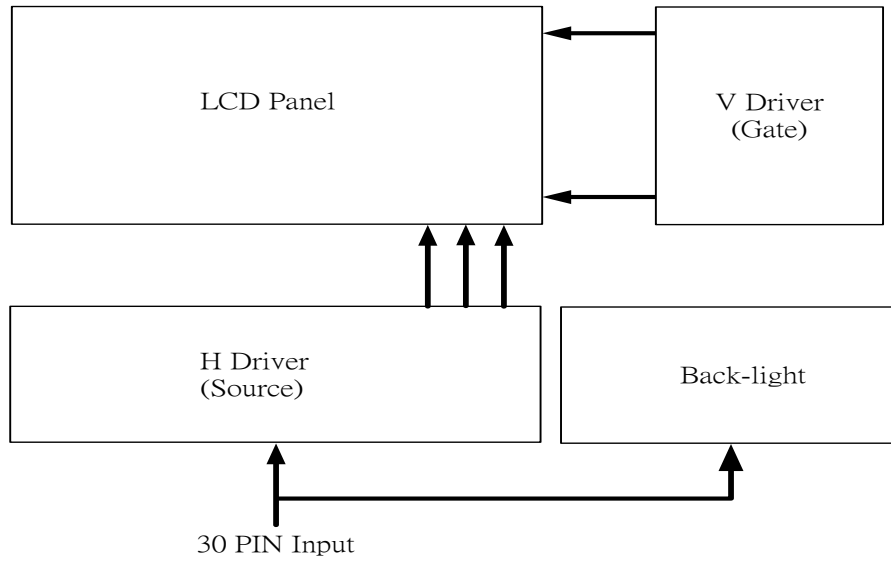

14. Packing

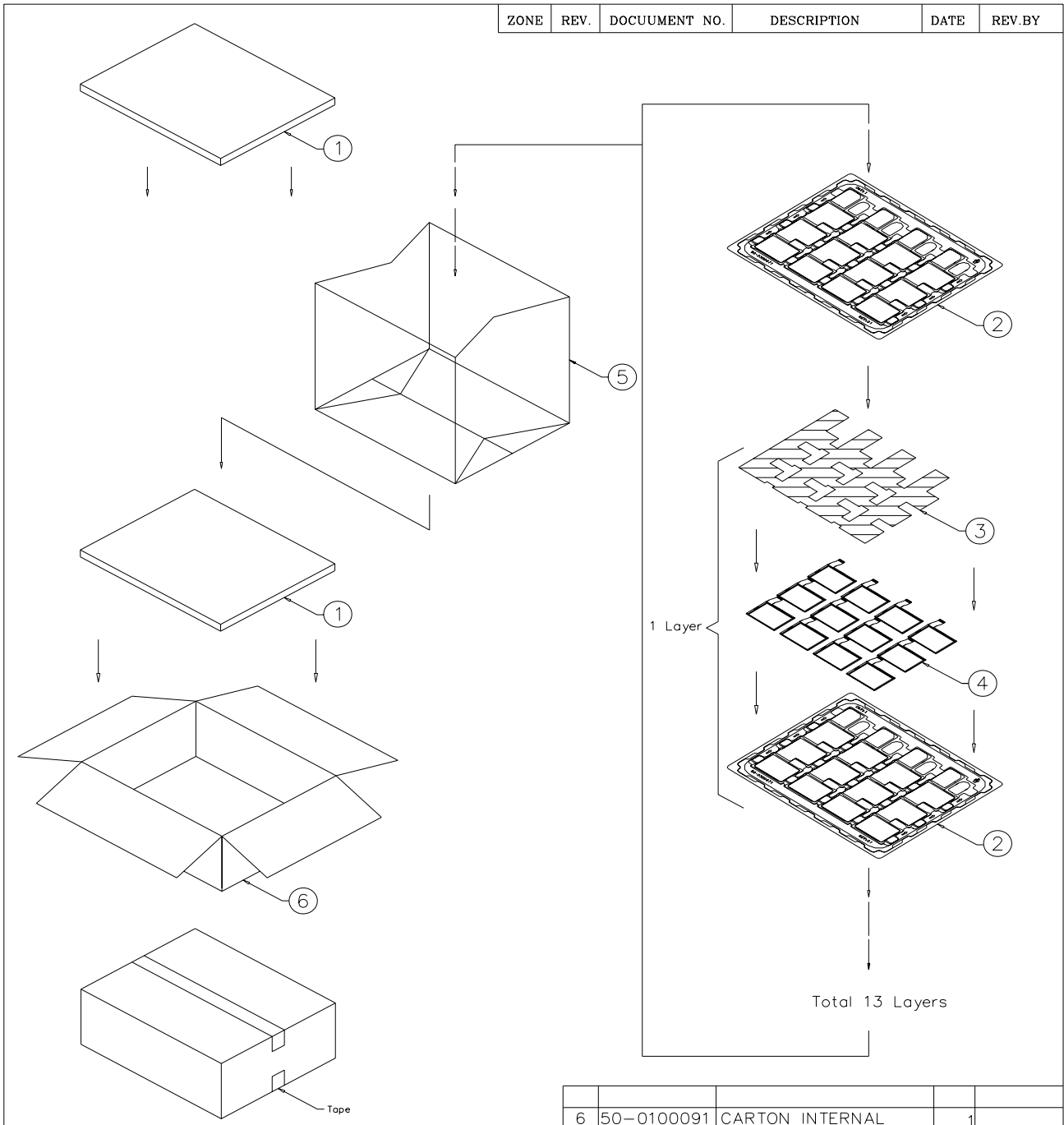

NOTE:

- 1. One layer include: 1 piece of cushion sheet, 12 pcs panel & 1 piece of tray.
- 2. Q'TY: 156 pcs panel/carton.
- 3. Dimension: 455*375*190mm
- 4. Weight: 8.5 KG

6	50-0100091	CARTON INTERNAL	1	
5	50-0500041	摺口袋450*380*700mm	1	抗靜電
4		PW036XS3	156	
3	50-0200039	EPE CUSHION SHEET	13	抗靜電
2	50-0300911	TRAY	14	抗靜電
1	50-0300491	EPE FOAM	2	
ITEM	PART NO.	DESCRIPTION	QTY	REMARK

MTL.SPEC.		UNSPECIFIED TOL'S		REMARK		元太科技股份有限公司 Prime View Internation Co.,Ltd.	
		ANGLE					
		ROUGHNESS					
APPROVE		SCALE	UNIT	SHEET	DWG.TITLE		
CHECK				1 OF 2	PW036XS3 PACKING Dim		
DESIGN	Jimmy	MTL.NO.		DWG.NO.		REV.	A4
	'04.04.12					01	SIZE

ZONE	REV.	DOCUMENT NO.	DESCRIPTION	DATE	REV. BY
------	------	--------------	-------------	------	---------

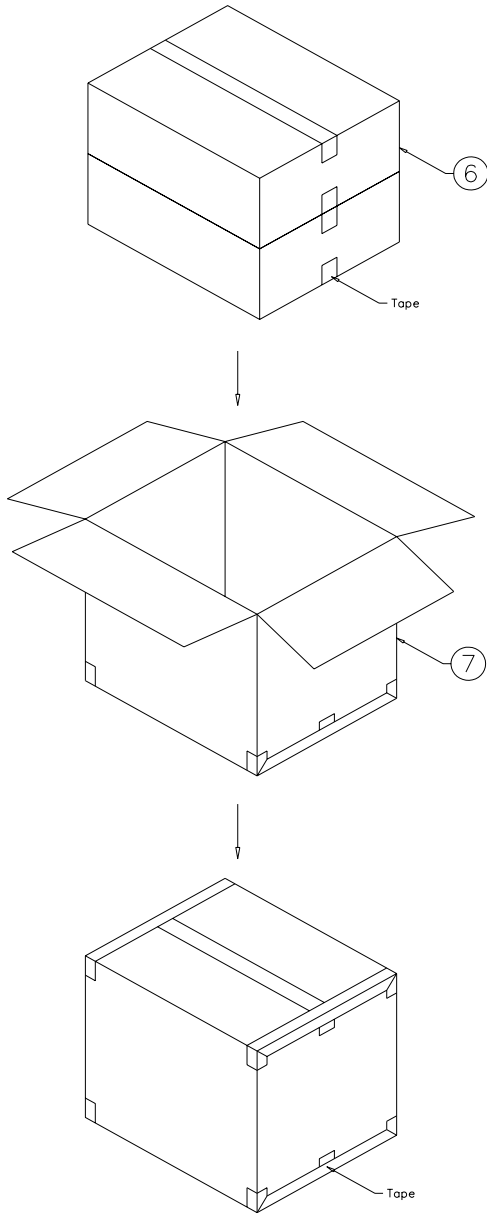

NOTE:

- 1.Q'TY: 312 pcs panel/carton.
- 2.Dimension: 480*396*405mm
- 3.Weight: 18.0 KG

7	50-0100101	CARTON EXTERNAL	1	
ITEM	PART NO.	DESCRIPTION	QTY	REMARK

MTL.SPEC.		UNSPECIFIED TOL'S		REMARK		 元太科技股份有限公司 Prime View Internation Co.,ltd.			
APPROVE		ANGLE		SCALE					
CHECK		ROUGHNESS						2 OF 2	
DESIGN		MTL.NO.		DWG.NO.		REV.		A4 SIZE	
Jimmy		'04.04.12				01			

Revision History

Rev.	Issued Date	Revised Contents
1.0	Jul. 06 , 2004	NEW
1.1	Jan.10 , 2005	Modify : Page04 : Mechanical Drawing of TFT-LCD Module(No Bending Area) Add: Page21 : Note : The protective film must be removed before temperature test. Delete: Page21 : Indication of Lot Number Label(Oracle system induction)

Appendix

LED B/L Application Circuit

