

### Features

- Low Forward Voltage Drop
- Guard Ring Die Construction for Transient Protection
- Ideal for low logic level applications
- Low Capacitance
- **Lead Free/RoHS Compliant (Note 3)**

### Mechanical Data

- Case: SOD-323
- Case Material: Molded Plastic. UL Flammability Classification Rating 94V-0
- Moisture Sensitivity: Level 1 per J-STD-020C
- Leads: Solderable per MIL-STD-202, Method 208
- Lead Free Plating (Matte Tin Finish annealed over Alloy 42 leadframe).
- Polarity: Cathode Band
- Marking: Marking Code and Date Code
- Marking Code: SR
- Weight: 0.004 grams (approx.)

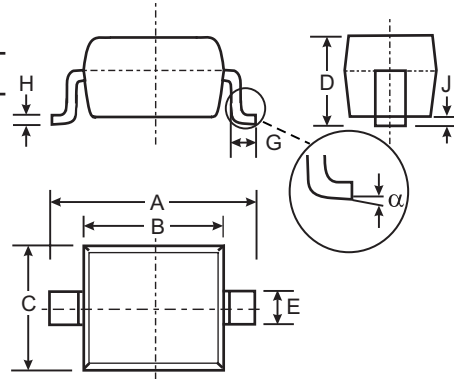

SOD-323		
Dim	Min	Max
A	2.30	2.70
B	1.60	1.80
C	1.20	1.40
D	1.05 Typical	
E	0.25	0.35
G	0.20	0.40
H	0.10	0.15
J	0.05 Typical	
$\alpha$	0°	8°
<b>All Dimensions in mm</b>		

### Maximum Ratings @ $T_A = 25^\circ\text{C}$ unless otherwise specified

Characteristic	Symbol	Value	Unit
Peak Repetitive Reverse Voltage Working Peak Reverse Voltage DC Blocking Voltage	$V_{RRM}$ $V_{RWM}$ $V_R$	40	V
RMS Reverse Voltage	$V_{R(RMS)}$	28	V
Maximum (Peak) Forward Current	$I_{FM}$	30	mA
Non-Repetitive Peak Forward Surge Current @ 8.3ms Single half sine-wave superimposed on rated load (JEDEC method)	$I_{FSM}$	200	mA
Power Dissipation	$P_d$	160	mW
Thermal Resistance, Junction to Ambient Air	$R_{\theta JA}$	625	$^\circ\text{C}/\text{W}$
Operating and Storage Temperature Range	$T_j, T_{STG}$	-40 to +125	$^\circ\text{C}$

### Electrical Characteristics @ $T_A = 25^\circ\text{C}$ unless otherwise specified

Characteristic	Symbol	Min	Typ	Max	Unit	Test Condition
Reverse Breakdown Voltage (Note 1)	$V_{(BR)R}$	40	—	—	V	$I_R = 10\mu\text{A}$
Forward Voltage Drop	$V_F$	—	290	370	mV	$I_F = 1\text{mA}$
Leakage Current (Note 1)	$I_R$	—	0.20	0.5	$\mu\text{A}$	$V_R = 30\text{V}$
Total Capacitance	$C_T$	—	2	—	pF	$V_R = 1\text{V}$ $f = 1.0\text{MHz}$

Notes: 1. Short duration test pulse to minimize self-heating effect.

### Ordering Information (Note 2)

Device	Packaging	Shipping
SDMK0340L-7-F	SOD-323	3000/Tape & Reel

Notes: 2. For Packaging Details, go to our website at <http://www.diodes.com/datasheets/ap02007.pdf>.  
3. No purposefully added lead.

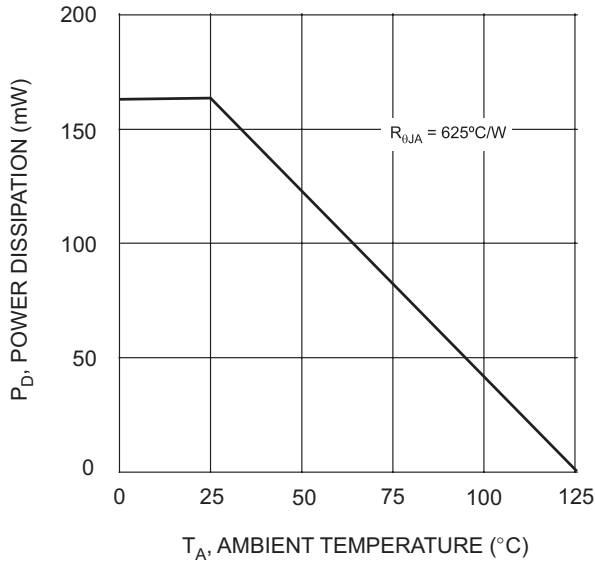

Fig. 1 Derating Curve

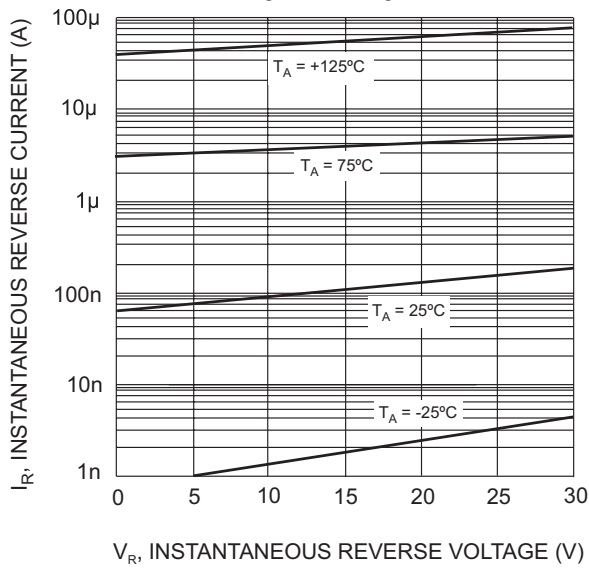

Fig. 3 Typical Reverse Characteristics

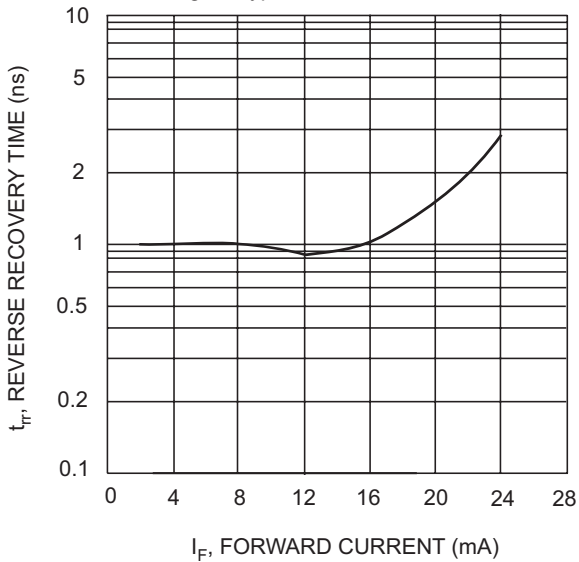

Fig. 5 Typical Reverse Recovery Time Characteristics

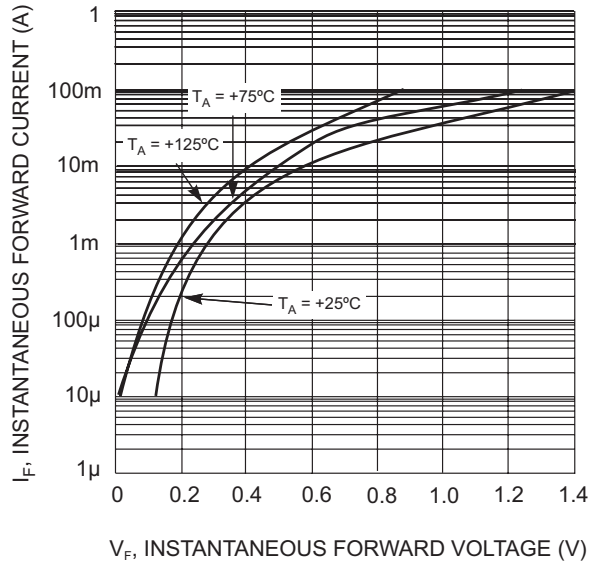

Fig. 2 Typical Forward Characteristics

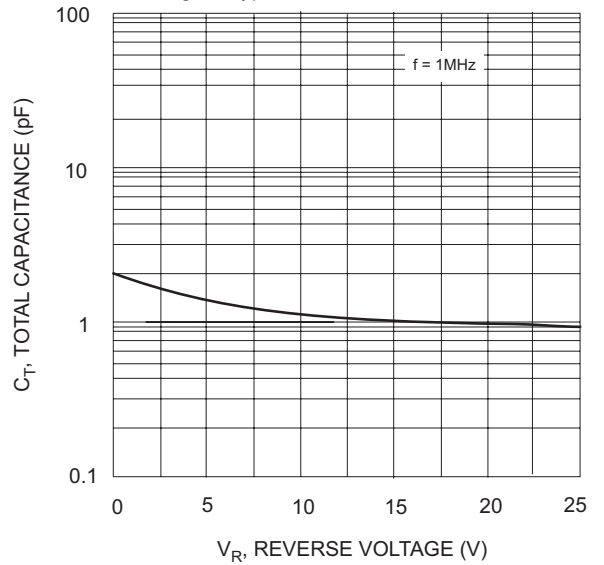

Fig. 4 Total Capacitance vs. Reverse Voltage

## Marking Information



SR = Product Type Marking Code  
See Sheet 1

### IMPORTANT NOTICE

Diodes Incorporated and its subsidiaries reserve the right to make modifications, enhancements, improvements, corrections or other changes without further notice to any product herein. Diodes Incorporated does not assume any liability arising out of the application or use of any product described herein; neither does it convey any license under its patent rights, nor the rights of others. The user of products in such applications shall assume all risks of such use and will agree to hold Diodes Incorporated and all the companies whose products are represented on our website, harmless against all damages.

### LIFE SUPPORT

Diodes Incorporated products are not authorized for use as critical components in life support devices or systems without the expressed written approval of the President of Diodes Incorporated.