

## Silicon Photodetector with Logic Output

### Description

TEKS5400 is a high sensitive photo Schmitt Trigger in a sideview molded plastic package with spherical lens. It is designed with an infrared filter to spectrally match to GaAs IR emitters ( $\lambda = 950 \text{ nm}$ ).

The photodetector is case compatible to the TSKS5400 GaAs IR emitting diode, allowing the user to assemble his own optical sensor.

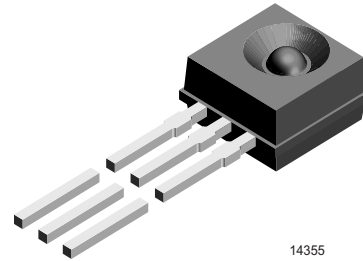

### Features

- Very high photo sensitivity
- Supply voltage range 4.5 to 16 V
- Low current consumption (2 mA)
- Side view plastic package with lens
- Angle of half sensitivity  $\varphi = \pm 30^\circ$
- TTL and CMOS compatible
- Open collector output
- Output signal inverted (active 'low')
- Case compatible with TSKS5400
- Lead-free device

### Parts Table

Part	Type differentiation	Ordering code	Remarks
TEKS5400-FSZ	1.27 mm Pin distance (lead to lead)	TEKS5400-FSZ	Height of taping 27 mm
TEKS5400-FGZ	2.00 mm Pin distance (lead to lead)	TEKS5400-FGZ	Height of taping 27 mm

### Absolute Maximum Ratings

$T_{amb} = 25^\circ\text{C}$ , unless otherwise specified

Parameter	Test condition	Symbol	Value	Unit
Supply voltage		$V_{S1}$	18	V
Output current		$I_O$	20	mA
Power dissipation		$P_V$	100	mW
Junction temperature		$T_J$	100	$^\circ\text{C}$
Operating temperature range		$T_{amb}$	- 25 to + 85	$^\circ\text{C}$
Storage temperature range		$T_{stg}$	- 40 to + 100	$^\circ\text{C}$
Soldering temperature	$t \leq 5 \text{ s}$ , 2 mm from body	$T_{sd}$	260	$^\circ\text{C}$

### Handling Precautions

Caution:

Connect a capacitor C of 100 nF between  $V_{S1}$  and ground!

### Basic Characteristics

$T_{amb} = 25\text{ }^{\circ}\text{C}$ , unless otherwise specified

Parameter	Test condition	Symbol	Min	Typ.	Max	Unit
Supply voltage		$V_{S1}/V_{S2}$	4.5		16	V
Supply current	$V_{S1} = 16\text{ V}$	$I_{S1}$		2	5	mA
Irradiance for threshold "On"	$\lambda = 950\text{ nm}, V_{S1} = 5\text{ V}$	$E_{eon}$	25	50	85	$\mu\text{W}/\text{cm}^2$
Hysteresis	$V_{S1} = 5\text{ V}$	$E_{eoff}/E_{eon}$		80		%
Angle of half sensitivity		$\phi$		$\pm 30$		$^{\circ}$
Wavelength of peak sensitivity		$\lambda_p$		920		nm
Range of Spectral Bandwidth		$\lambda_{0.5}$		600 to 1020		nm
Output voltage	$I_{OL} = 16\text{ mA}, V_{S1} = 5\text{ V}, E_e \geq E_{on}$	$V_{OL}$		0.2	0.4	V
High level output current	$V_{S1} = V_{S2} = 16\text{ V}, I_F = 0$	$I_{OH}$			1	$\mu\text{A}$

### Switching Characteristics

$T_{amb} = 25\text{ }^{\circ}\text{C}$ , unless otherwise specified

Parameter	Test condition	Symbol	Typ.	Unit
Rise time	$V_{S1} = V_{S2} = 5\text{ V}, R_L = 1\text{ k}\Omega,$ $E_e = 3 * E_{eon}, \lambda = 950\text{ nm}$	$t_r$	100	ns
Fall time	$V_{S1} = V_{S2} = 5\text{ V}, R_L = 1\text{ k}\Omega,$ $E_e = 3 * E_{eon}, \lambda = 950\text{ nm}$	$t_f$	20	ns
Turn-on time	$V_{S1} = V_{S2} = 5\text{ V}, R_L = 1\text{ k}\Omega,$ $E_e = 3 * E_{eon}, \lambda = 950\text{ nm}$	$t_{on}$	1.5	$\mu\text{s}$
Turn-off time	$V_{S1} = V_{S2} = 5\text{ V}, R_L = 1\text{ k}\Omega,$ $E_e = 3 * E_{eon}, \lambda = 950\text{ nm}$	$t_{off}$	3.0	$\mu\text{s}$
Cut off frequency	$V_{S1} = V_{S2} = 5\text{ V}, R_L = 1\text{ k}\Omega,$ $E_e = 3 * E_{eon}, \lambda = 950\text{ nm}$	$f_{sw}$	200	kHz

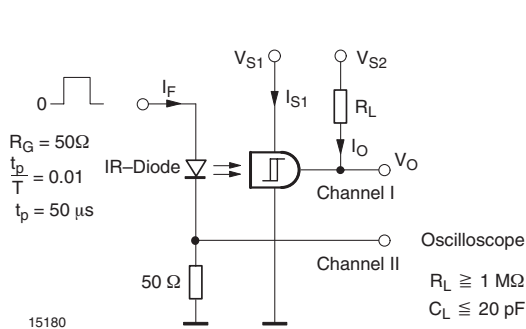

Fig. 1 Test Circuit

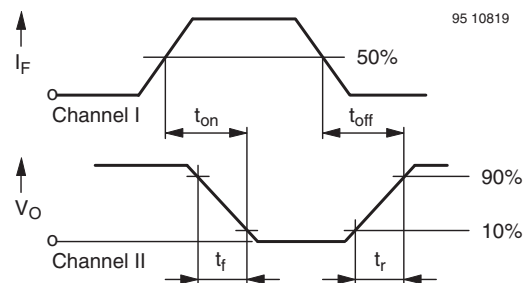

Fig. 2 Pulse Diagram

## Typical Characteristics ( $T_{amb} = 25\text{ }^{\circ}\text{C}$ unless otherwise specified)

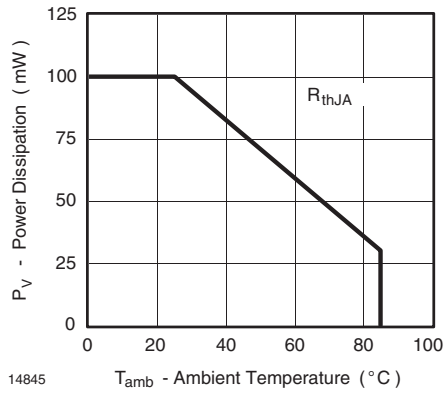

Fig. 3 Power Dissipation vs. Ambient Temperature

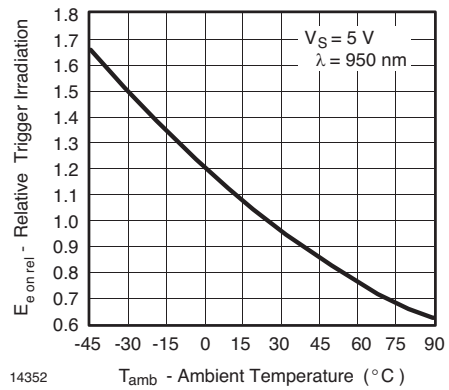

Fig. 6 Rel. Trigger Irradiation vs. Ambient Temperature

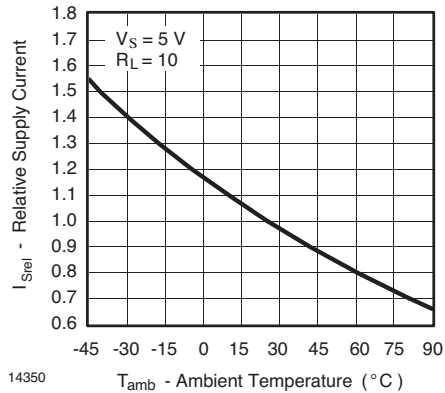

Fig. 4 Rel. Supply Current vs. Ambient Temperature

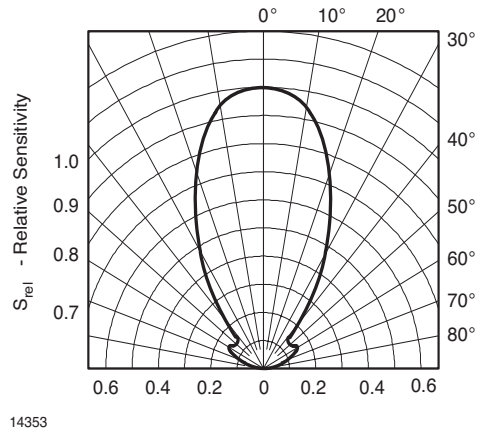

Fig. 7 Relative Radiant Sensitivity vs. Angular Displacement

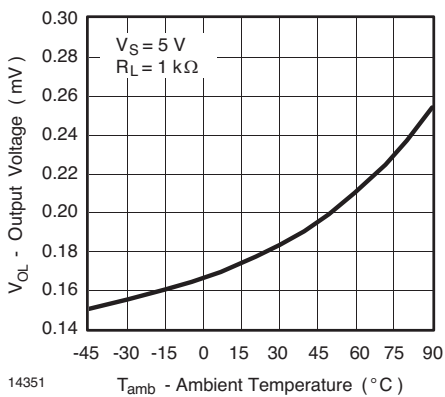

Fig. 5 Output Voltage vs. Ambient Temperature



## **Ozone Depleting Substances Policy Statement**

It is the policy of **Vishay Semiconductor GmbH** to

1. Meet all present and future national and international statutory requirements.
2. Regularly and continuously improve the performance of our products, processes, distribution and operating systems with respect to their impact on the health and safety of our employees and the public, as well as their impact on the environment.

It is particular concern to control or eliminate releases of those substances into the atmosphere which are known as ozone depleting substances (ODSs).

The Montreal Protocol (1987) and its London Amendments (1990) intend to severely restrict the use of ODSs and forbid their use within the next ten years. Various national and international initiatives are pressing for an earlier ban on these substances.

**Vishay Semiconductor GmbH** has been able to use its policy of continuous improvements to eliminate the use of ODSs listed in the following documents.

1. Annex A, B and list of transitional substances of the Montreal Protocol and the London Amendments respectively
2. Class I and II ozone depleting substances in the Clean Air Act Amendments of 1990 by the Environmental Protection Agency (EPA) in the USA
3. Council Decision 88/540/EEC and 91/690/EEC Annex A, B and C (transitional substances) respectively.

**Vishay Semiconductor GmbH** can certify that our semiconductors are not manufactured with ozone depleting substances and do not contain such substances.

**We reserve the right to make changes to improve technical design  
and may do so without further notice.**

Parameters can vary in different applications. All operating parameters must be validated for each customer application by the customer. Should the buyer use Vishay Semiconductors products for any unintended or unauthorized application, the buyer shall indemnify Vishay Semiconductors against all claims, costs, damages, and expenses, arising out of, directly or indirectly, any claim of personal damage, injury or death associated with such unintended or unauthorized use.

Vishay Semiconductor GmbH, P.O.B. 3535, D-74025 Heilbronn, Germany  
Telephone: 49 (0)7131 67 2831, Fax number: 49 (0)7131 67 2423