

## Silicon PIN Photodiode

### Description

TESP5700 PIN photodiode is applicable to high speed data transmission specifically at low reverse voltage. Black epoxy package include side view lens and daylight filter, matched to high speed IR emitters.

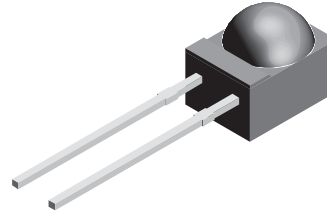

16936

### Features

- Ultra high speed at low supply voltage
- Fast response times  $t_r/t_f = 10$  ns
- High cut-off frequency  $f_c = 35$  MHz
- Low operating voltage  $V_R = 2$  V
- High sensitivity  $s(\lambda) = 0.57$  A/W
- Low junction capacitance
- High efficient side view lens
- Wide viewing angle  $\varphi = \pm 60^\circ$
- Daylight filter, matched to IR emitters using  $\lambda_p = 850$  nm or  $\lambda_p = 870$  nm
- Lead-free component
- Component in accordance to RoHS 2002/95/EC and WEEE 2002/96/EC

### Applications

High speed data transmission specifically using low supply voltage

Infrared remote control and free air data transmission systems in combination with IR emitters TSFF5200 or TSFF5400.

### Parts Table

Part	Ordering code	Remarks
TESP5700	TESP5700	MOQ 7500 pc

### Absolute Maximum Ratings

$T_{amb} = 25^\circ\text{C}$ , unless otherwise specified

Parameter	Test condition	Symbol	Value	Unit
Reverse Voltage		$V_R$	60	V
Power Dissipation	$T_{amb} \leq 25^\circ\text{C}$	$P_V$	215	mW
Junction Temperature		$T_j$	100	$^\circ\text{C}$
Operating Temperature Range		$T_{amb}$	- 40 to + 100	$^\circ\text{C}$
Storage Temperature Range		$T_{stg}$	- 40 to + 100	$^\circ\text{C}$
Soldering Temperature	$t \leq 5$ s	$T_{sd}$	260	$^\circ\text{C}$
Thermal Resistance Junction/ Ambient		$R_{thJA}$	350	K/W

### Basic Characteristics

$T_{amb} = 25\text{ }^{\circ}\text{C}$ , unless otherwise specified

Parameter	Test condition	Symbol	Min	Typ.	Max	Unit
Forward Voltage	$I_F = 50\text{ mA}$	$V_F$		0.9	1.3	V
Breakdown Voltage	$I_R = 100\text{ }\mu\text{A}$ , $E = 0$	$V_{(BR)}$	60			V
Reverse Dark Current	$V_R = 10\text{ V}$ , $E = 0$	$I_{ro}$		1	10	nA
Diode capacitance	$V_R = 0\text{ V}$ , $f = 1\text{ MHz}$ , $E = 0$	$C_D$		17		pF
Serial Resistance	$V_R = 2\text{ V}$ , $f = 1\text{ MHz}$	$R_S$		40		$\Omega$
Open Circuit Voltage	$E_e = 1\text{ mW/cm}^2$ , $\lambda = 870\text{ nm}$	$V_o$		430		mV
Temp. Coefficient of $V_o$	$E_e = 1\text{ mW/cm}^2$ , $\lambda = 870\text{ nm}$	$TK_{V_o}$		-2.6		mV/K
Short Circuit Current	$E_e = 1\text{ mW/cm}^2$ , $\lambda = 870\text{ nm}$	$I_k$		23		$\mu\text{A}$
Reverse Light Current	$E_e = 1\text{ mW/cm}^2$ , $\lambda = 870\text{ nm}$ , $V_R = 2\text{ V}$	$I_{ra}$	16	25		$\mu\text{A}$
Temp. Coefficient of $I_{ra}$	$E_e = 1\text{ mW/cm}^2$ , $\lambda = 870\text{ nm}$ , $V_R = 2\text{ V}$	$TK_{I_{ra}}$		0.13		%/K
Absolute Spectral Sensitivity	$V_R = 2\text{ V}$ , $\lambda = 870\text{ nm}$	$s(\lambda)$		0.57		A/W
	$V_R = 5\text{ V}$ , $\lambda = 950\text{ nm}$	$s(\lambda)$		0.37		A/W
Angle of Half Sensitivity		$\phi$		$\pm 60$		deg
Wavelength of Peak Sensitivity		$\lambda_p$		870		nm
Range of Spectral Bandwidth		$\lambda_{0.5}$		790 to 980		nm
Rise Time	$V_R = 2\text{ V}$ , $R_L = 50\text{ }\Omega$ , $\lambda = 870\text{ nm}$	$t_r$		10		ns
Fall Time	$V_R = 2\text{ V}$ , $R_L = 50\text{ }\Omega$ , $\lambda = 870\text{ nm}$	$t_f$		10		ns
Cut-Off Frequency	$V_R = 2\text{ V}$ , $R_L = 50\text{ }\Omega$ , $\lambda = 870\text{ nm}$	$f_c$		35		MHz

### Typical Characteristics ( $T_{amb} = 25\text{ }^{\circ}\text{C}$ unless otherwise specified)

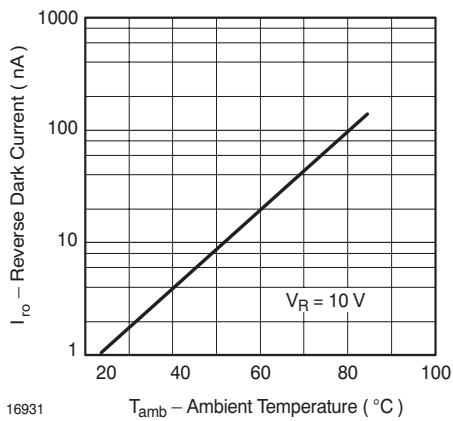

Figure 1. Reverse Dark Current vs. Ambient Temperature

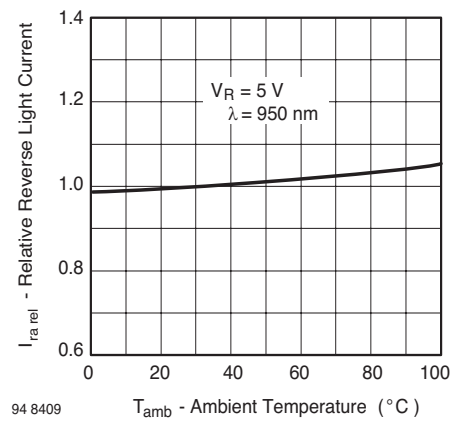

Figure 2. Relative Reverse Light Current vs. Ambient Temperature

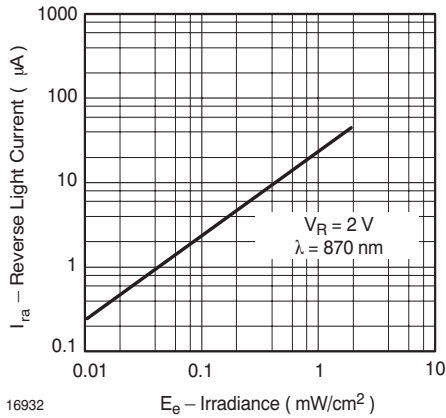

Figure 3. Reverse Light Current vs. Irradiance

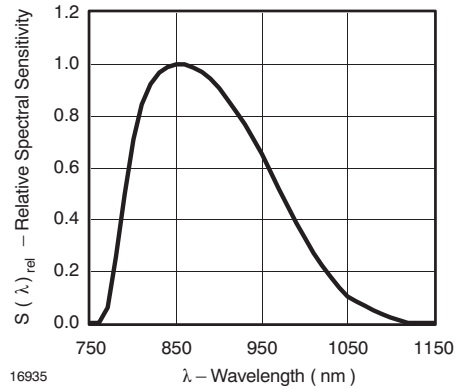

Figure 6. Relative Spectral Sensitivity vs. Wavelength

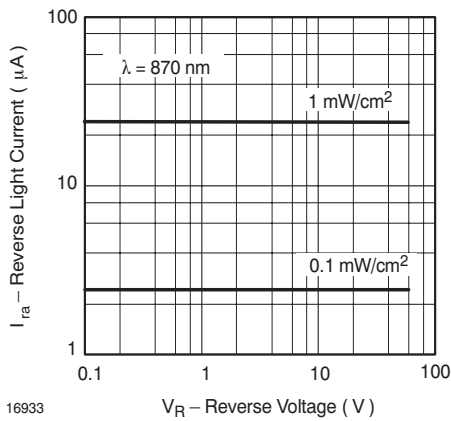

Figure 4. Reverse Light Current vs. Reverse Voltage

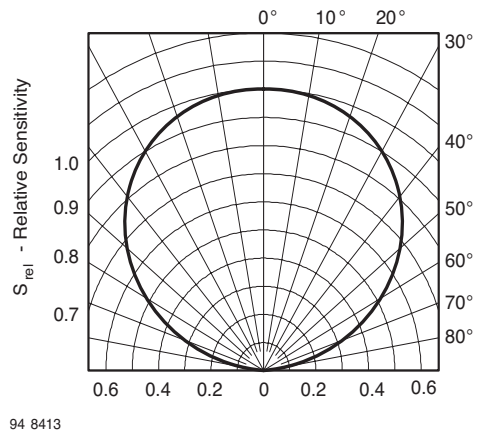

Figure 7. Relative Radiant Sensitivity vs. Angular Displacement

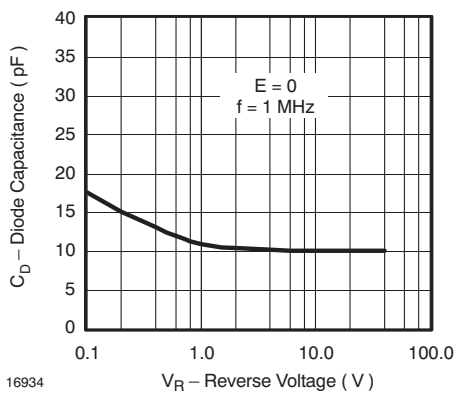
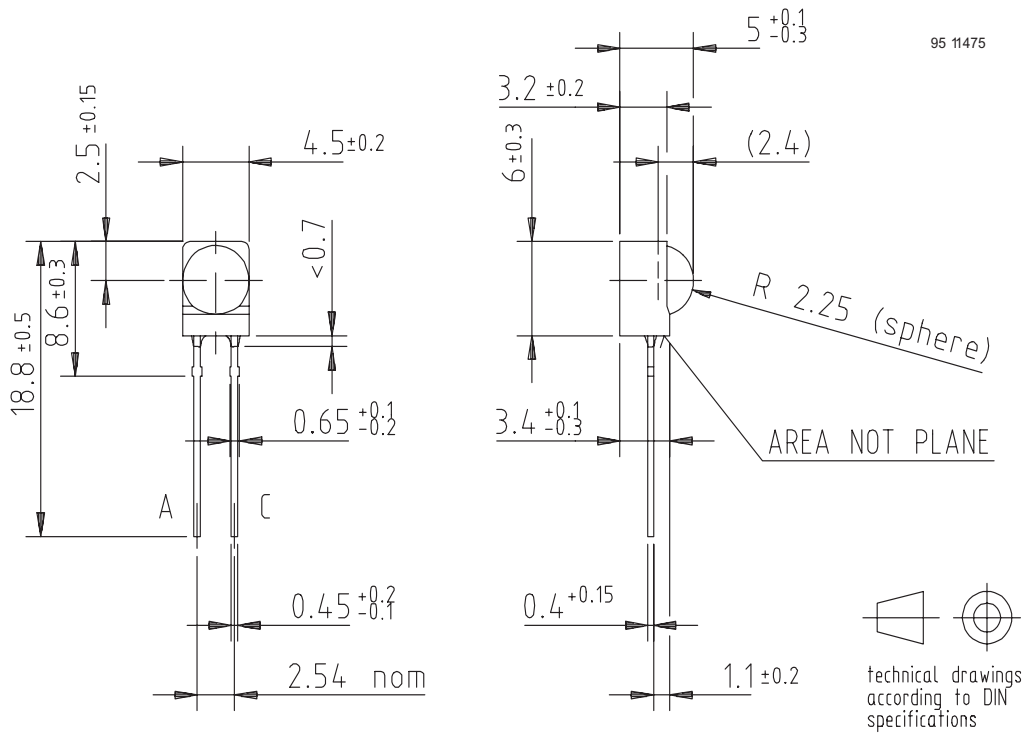

Figure 5. Diode Capacitance vs. Reverse Voltage

### Package Dimensions in mm



## **Ozone Depleting Substances Policy Statement**

It is the policy of Vishay Semiconductor GmbH to

1. Meet all present and future national and international statutory requirements.
2. Regularly and continuously improve the performance of our products, processes, distribution and operating systems with respect to their impact on the health and safety of our employees and the public, as well as their impact on the environment.

It is particular concern to control or eliminate releases of those substances into the atmosphere which are known as ozone depleting substances (ODSs).

The Montreal Protocol (1987) and its London Amendments (1990) intend to severely restrict the use of ODSs and forbid their use within the next ten years. Various national and international initiatives are pressing for an earlier ban on these substances.

Vishay Semiconductor GmbH has been able to use its policy of continuous improvements to eliminate the use of ODSs listed in the following documents.

1. Annex A, B and list of transitional substances of the Montreal Protocol and the London Amendments respectively
2. Class I and II ozone depleting substances in the Clean Air Act Amendments of 1990 by the Environmental Protection Agency (EPA) in the USA
3. Council Decision 88/540/EEC and 91/690/EEC Annex A, B and C (transitional substances) respectively.

Vishay Semiconductor GmbH can certify that our semiconductors are not manufactured with ozone depleting substances and do not contain such substances.

We reserve the right to make changes to improve technical design and may do so without further notice.

Parameters can vary in different applications. All operating parameters must be validated for each customer application by the customer. Should the buyer use Vishay Semiconductors products for any unintended or unauthorized application, the buyer shall indemnify Vishay Semiconductors against all claims, costs, damages, and expenses, arising out of, directly or indirectly, any claim of personal damage, injury or death associated with such unintended or unauthorized use.

Vishay Semiconductor GmbH, P.O.B. 3535, D-74025 Heilbronn, Germany  
Telephone: 49 (0)7131 67 2831, Fax number: 49 (0)7131 67 2423