

Quad Operational Amplifier

GENERAL DESCRIPTION

The XR-4212 is an array of four independent internally compensated operational amplifiers on a single silicon chip, each similar to the popular 741, but with a power consumption less than one 741. Good thermal tracking and matched gain-bandwidth products make these Quad Op-amps useful for active filter applications.

FEATURES

- Same Pinout as MC3403 and LM324
- Low Power Consumption—50 mW typ. and 120mW max.
- Short-Circuit Protection
- Internal Frequency Compensation
- No Latch-Up
- Wide Common-Mode and Differential Voltage Ranges
- Matched Gain-Bandwidth

APPLICATIONS

- Buffer Amplifiers
- Summing/Differencing Amplifiers
- Instrumentation Amplifiers
- Active Filters
- Signal Processing
- Sample and Differencing
- I to V Converters
- Integrators
- Simulated Components
- Analog Computers

ABSOLUTE MAXIMUM RATINGS

Supply Voltage	
XR-4212M	± 22V
XR-4212C	± 18V
Common Mode Voltage	V_{EE} to V_{CC}
Output Short-Circuit Duration	Indefinite
Differential Input Voltage	± 30V
Internal Power Dissipation	
Ceramic Package:	750 mW
Derate above $T_A = +25^\circ\text{C}$	6 mW/ $^\circ\text{C}$
Plastic Package:	625 mW
Derate above $T_A = +25^\circ\text{C}$	5 mW/ $^\circ\text{C}$
Storage Temperature Range:	- 65 $^\circ\text{C}$ to + 150 $^\circ\text{C}$

FUNCTIONAL BLOCK DIAGRAM

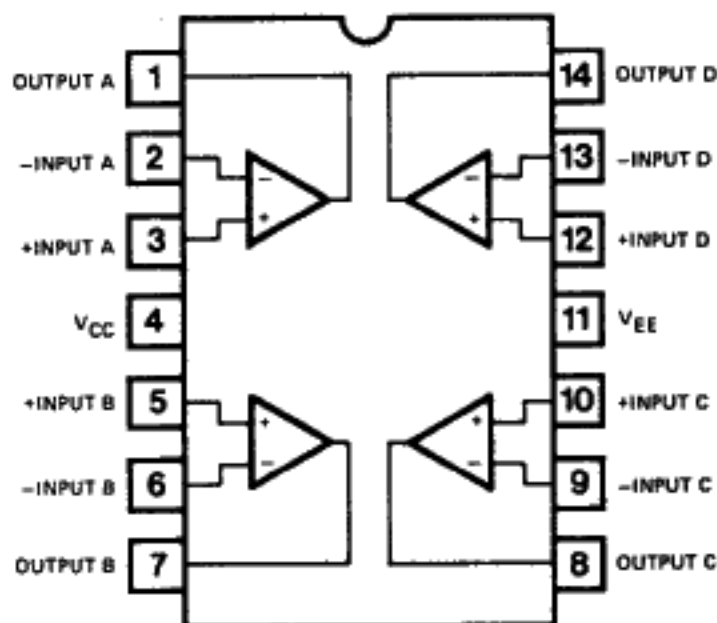

ORDERING INFORMATION

Part Number	Package	Operating Temperature
XR-4212M	Ceramic	- 55 $^\circ\text{C}$ to + 125 $^\circ\text{C}$
XR-4212CN	Ceramic	0 $^\circ\text{C}$ to + 70 $^\circ\text{C}$
XR-4212CP	Plastic	0 $^\circ\text{C}$ to + 70 $^\circ\text{C}$

SYSTEM DESCRIPTION

The XR-4212 is a quad operational amplifier featuring improved performance over industry standard devices such as the 741.

XR-4212

ELECTRICAL CHARACTERISTICS

Test Conditions: $T_A = +25^\circ\text{C}$, $V_S = \pm 15\text{V}$, unless otherwise specified.

PARAMETERS	XR-4212M			XR-4212C			UNITS	SYMBOLS	CONDITIONS
	MIN	TYP	MAX	MIN	TYP	MAX			
Input Offset Voltage		1	5.0		1	6.0	mV	$ V_{io} $	$R_S \leq 10\text{K}\Omega$
Input Offset Current		10	50		10	50	nA	$ I_{io} $	
Input Bias Current		80	500		80	500	nA	$ I_b $	
Input Resistance	0.3	1.8		0.3	1.8		M Ω	R_{in}	
Large Signal Voltage Gain	20	60		5	40		V/mV	A_{VOL}	$R_L \geq 2\text{K}\Omega$ $V_{out} = \pm 10\text{V}$
Output Voltage Swing	± 12	± 14		± 12	± 14		V	V_{out}	$R_L \geq 10\text{K}\Omega$
	± 10	± 12		± 10	± 12		V	V_{out}	$R_L \geq 2\text{K}\Omega$
Input Voltage Range	± 12	± 13.5		± 12	± 13.5		V	V_{ICM}	
Common Mode Rejection Ratio	70	105		70	105		dB	CMRR	$R_S \leq 10\text{K}\Omega$
Supply Voltage Rejection Ratio		10	150		10	150	$\mu\text{V/V}$	PSRR	$R_S \leq 10\text{K}\Omega$
Power Consumption		50	120		50	120	mW	P_I	
Transient Response (unity gain) Risettime Overshoot		0.07			0.07		μs	t_r	$V_{in} = 20\text{mV}$ $R_L = 2\text{K}\Omega$ $C_L \leq 100\text{pF}$
		20			20		%	t_o	
Unity Gain Bandwidth	2.0	3.0			3.0		MHz	BW	
Slew Rate (unity gain)		1.6			1.6		V/ μs	dV_{out}/dt	$R_L \geq 2\text{K}\Omega$
Channel Separation (open loop) (Gain of 100)		120			120		dB		$f = 10\text{KHz}$ $R_S = 1\text{K}\Omega$
		105			105		dB		$f = 10\text{KHz}$ $R_S = 1\text{K}\Omega$
The following specifications apply for $-55^\circ\text{C} \leq T_A \leq +125^\circ\text{C}$ for XR-4212M: $0^\circ\text{C} \leq T_A \leq +70^\circ\text{C}$ for XR-4212C									
Input Offset Voltage			6.0			7.5	mV	$ V_{io} $	$R_S \leq 10\text{K}\Omega$
Input Offset Current			200			200	nA	$ I_{io} $	
Input Bias Current			1500			800	nA	I_b	
Large-Signal Voltage Gain	20			5			V/mV	A_{VOL}	$R_L \geq 2\text{K}\Omega$ $V_{out} = \pm 10\text{V}$
Output Voltage Swing	± 10			± 10			V	V_{out}	$R_L \geq 2\text{K}\Omega$
Power Consumption			150 200			150 200	mW mW	P_I P_I	$V_S = \pm 15\text{V}$ $T_A = \text{High}$ $T_A = \text{Low}$
Output Short-Circuit Current	5	17	35	5	17	35	mA	I_{SC}	

TYPICAL PARAMETER MATCHING:

Test Conditions: $T_A = +25^\circ\text{C}$, $V_S = \pm 15\text{V}$ unless otherwise noted

PARAMETERS	XR-4212M TYP	XR-4212C TYP	UNITS	SYMBOLS	CONDITIONS
Input Offset Voltage	± 1.0	± 2.0	mV	$ V_{io} $	$R_S \geq 10\text{K}\Omega$
Input Offset Current	± 7.5	± 7.5	nA	$ I_{io} $	
Input Bias Current	± 15	± 15	nA	I_b	
Voltage Gain	± 0.5	± 1.0	dB	A_{VOL}	$R_S \geq 2\text{K}\Omega$

XR-4212

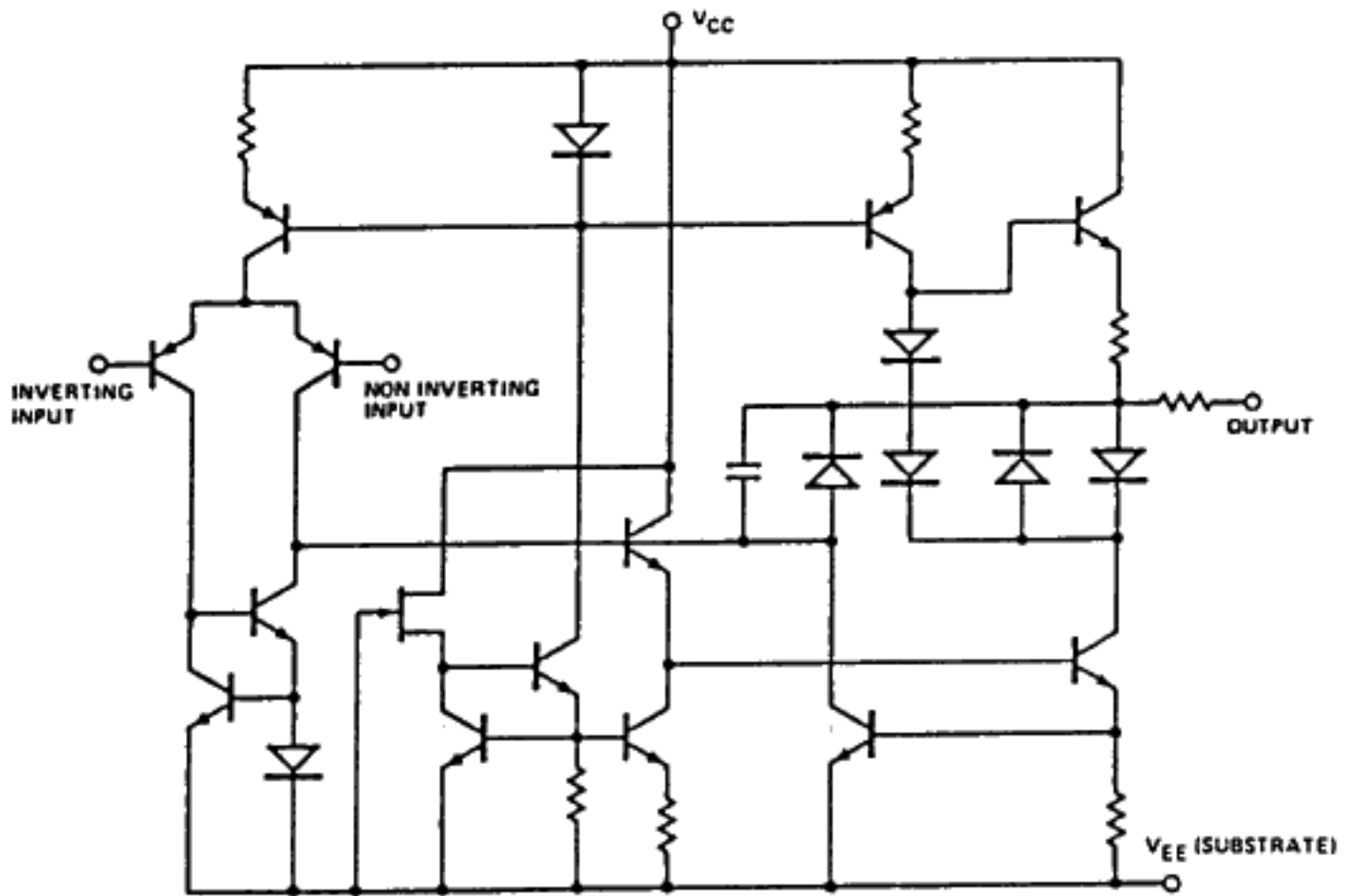

1/4 of XR-4212

EQUIVALENT SCHEMATIC DIAGRAM

Quad Line Driver/Receiver

GENERAL DESCRIPTION

The XR-1488 is a monolithic quad line driver designed to interface data terminal equipment with data communications equipment in conformance with the specifications of EIA Standard No. RS232C. This extremely versatile integrated circuit can be used to perform a wide range of applications. Features such as output current limiting, independent positive and negative power supply driving elements, and compatibility with all DTL and TTL logic families greatly enhance the versatility of the circuit.

The XR-1489A is a monolithic quad line receiver designed to interface data terminal equipment with data communications equipment. The XR-1489A quad receiver along with its companion circuit, the XR-1488 quad driver, provide a complete interface system between DTL or TTL logic levels and the RS232C defined voltage and impedance levels.

ABSOLUTE MAXIMUM RATINGS

Power Supply		
XR-1488	± 15 Vdc	
XR-1489A	+ 10 Vdc	
Power Dissipation		
Ceramic Package	1000 mW	
Derate above +25°C	6.7 mW/°C	
Plastic Package	650 mW/°C	
Derate above +25°C	5 mW/°C	

ORDERING INFORMATION

Part Number	Package	Operating Temperature
XR-1488N	Ceramic	0°C to +70°C
XR-1488P	Plastic	0°C to +70°C
XR-1489AN	Ceramic	0°C to +70°C
XR-1489AP	Plastic	0°C to +70°C

FUNCTIONAL BLOCK DIAGRAMS

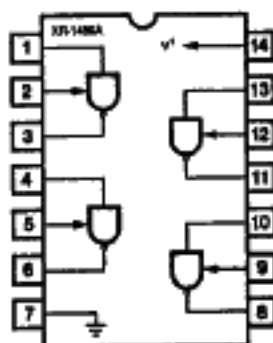
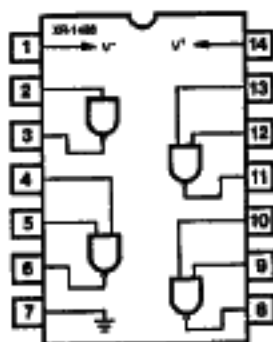

SYSTEM DESCRIPTION

The XR-1488 and XR-1489A are a matched set of quad line drivers and line receivers designed for interfacing between TTL/DTL and RS232C data communication lines.

The XR-1488 contains four independent split supply line drivers, each with a ± 10 mA current limited output. For RS232C applications, the slew rate can be reduced to the 30 V/ μ S limit by shunting the output to ground with a 410 pF capacitor. The XR-1489A contains four independent line receivers, designed for interfacing RS232C to TTL/DTL. Each receiver features independently programmable switching thresholds with hysteresis, and input protection to ± 30 V. The output can typically source 3 mA and sink 20 mA.