

MITSUBISHI IGBT Module

MG400V2YS60A

High Power Switching Applications

Motor Control Applications

- The electrodes are isolated from case.
- Enhancement-mode
- Thermal output terminal (TH)

Equivalent Circuit

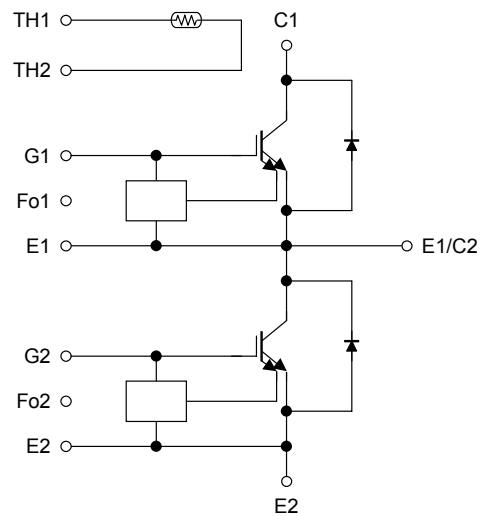

Package Dimensions

Unit: mm

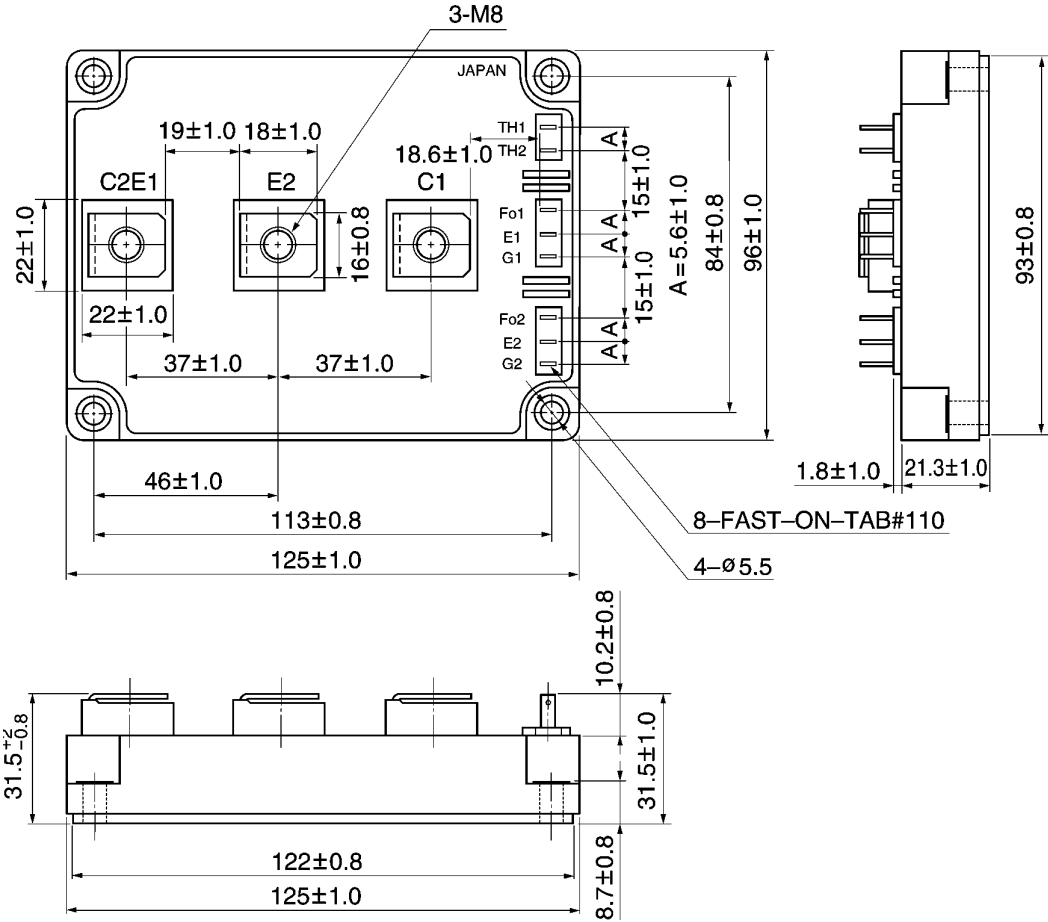

Weight: 680 g (typ.)

Maximum Ratings (Ta = 25°C)

Characteristic		Symbol	Rating	Unit
Collector-emitter voltage		V_{CES}	1700	V
Gate-emitter voltage		V_{GES}	±20	V
Collector current	DC	I_C	400	A
Forward current	DC	I_F	400	A
Collector power dissipation (Tc = 25°C)		P_C	4300	W
Junction temperature		T_j	150	°C
Storage temperature range		T_{stg}	-40~125	°C
Isolation voltage		V_{isol}	4000 (AC 1 min)	V
Screw torque	Terminal: M8	—	10	N·m
	Mounting: M5	—	3	N·m

Electrical Characteristics (Ta = 25°C)

Characteristic		Symbol	Test Condition	Min.	Typ.	Max.	Unit	
Gate leakage current		I_{GES}	$V_{GE} = \pm 20V, V_{CE} = 0V$	—	—	±10	μA	
Collector cut-off current		I_{CES}	$V_{CE} = 1700V, V_{GE} = 0V$	—	—	1	mA	
Gate-emitter cut-off voltage		$V_{GE(off)}$	$I_C = 400mA, V_{CE} = 5V$	4.5	5.5	6.5	V	
Collector-emitter saturation voltage		$V_{CE(sat)}$	$I_C = 400A$ $V_{GE} = 15V$	$T_j = 25^\circ C$	—	3.0	3.4	V
				$T_j = 125^\circ C$	—	3.8	4.2	
Input capacitance		C_{ies}	$V_{CE} = 10V, V_{GE} = 0V,$ $f = 1MHz$	—	45000	—	pF	
Gate-emitter voltage		V_{GE}	—	13	15	17	V	
Gate resistance		R_G	—	8.2	—	15	Ω	
Switching time	Turn-on delay time	$t_{d(on)}$	Inductive load $V_{CC} = 900V$ $I_C = 400A$ $V_{GE} = \pm 15V$ $R_G = 8.2\Omega$ (Note)	—	0.35	—	μs	
	Rise time	t_r		—	0.2	—		
	Turn-on time	t_{on}		—	0.55	—		
	Turn-off delay time	$t_{d(off)}$		—	0.9	—		
	Fall time	t_f		—	0.4	0.6		
	Turn-off time	t_{off}		—	1.3	—		
Forward voltage		V_F	$I_F = 400A,$ $V_{GE} = 0V$	$T_j = 25^\circ C$	—	3.2	4.2	V
				$T_j = 125^\circ C$	—	2.4	—	
Reverse recovery time		t_{rr}	$I_F = 400A, V_{GE} = -15V$ $di/dt = 2000A/\mu s$	—	0.20	0.40	μs	
Thermal resistance		$R_{th(j-c)}$	Transistor stage	—	—	0.029	°C / W	
			Diode stage	—	—	0.056		
RTC operating current		I_{rtc}	$T_j = 25^\circ C$	800	—	—	A	

Thermistor

Characteristic	Symbol	Test Condition	Min.	Typ.	Max.	Unit
Zero power resistance	R25	T _c = 25°C	—	100	—	kΩ
B value	R25 / 85	T _c = 25°C / T _c = 85°C	—	4390	—	K
Isolation voltage		T _c = 25°C	2500	—	—	V _{rms}

(Note) : Switching time measurement circuit and input / output waveforms

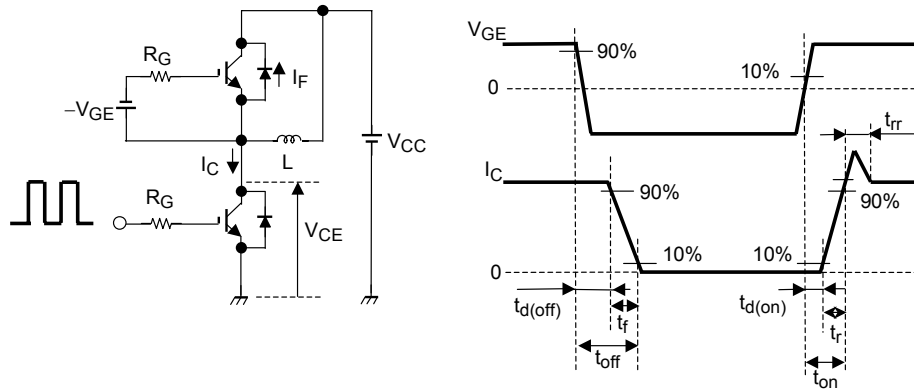

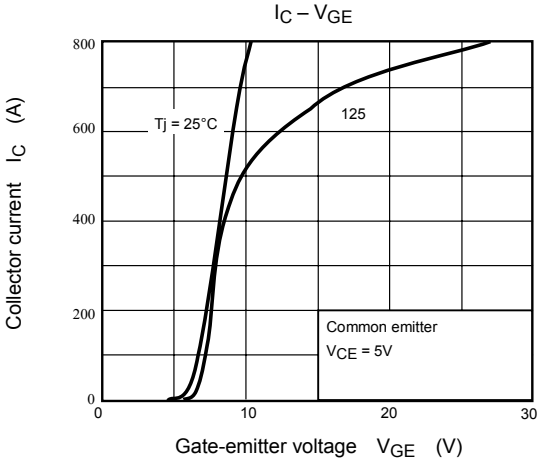
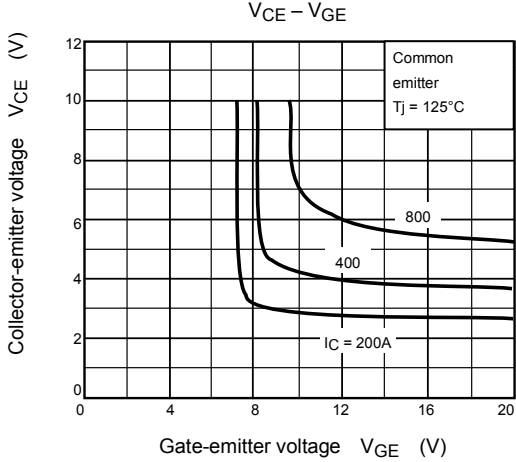
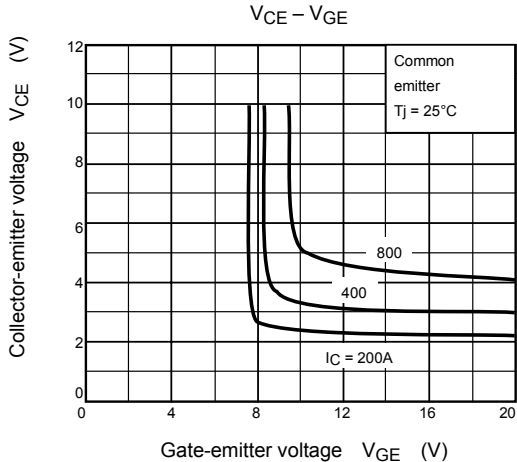
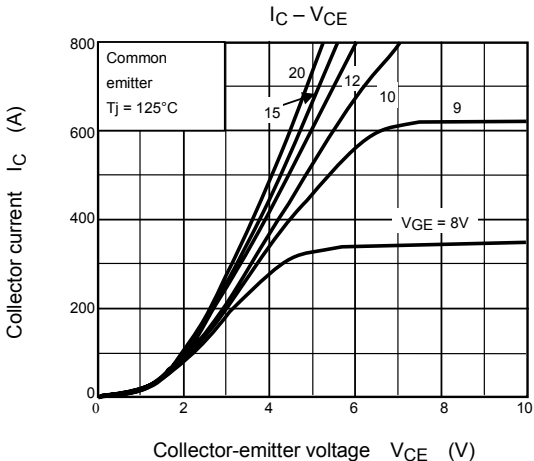
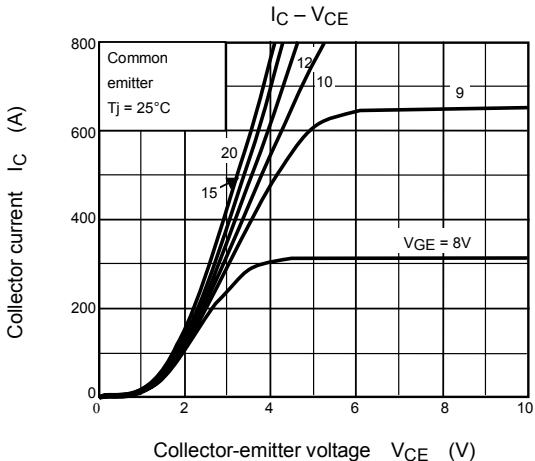

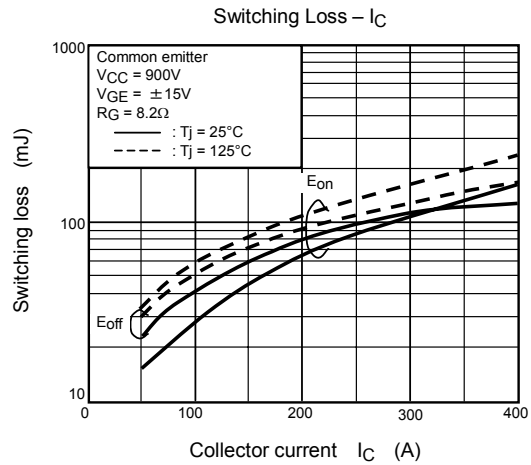
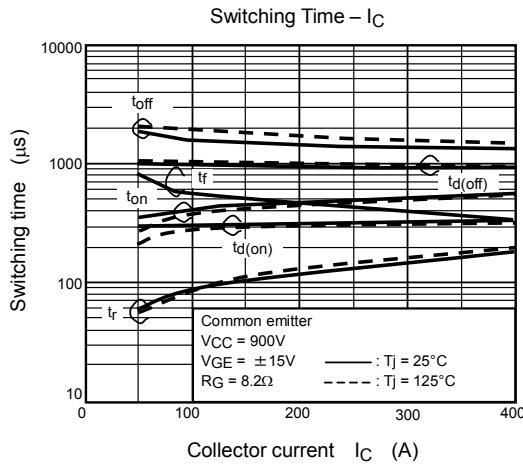
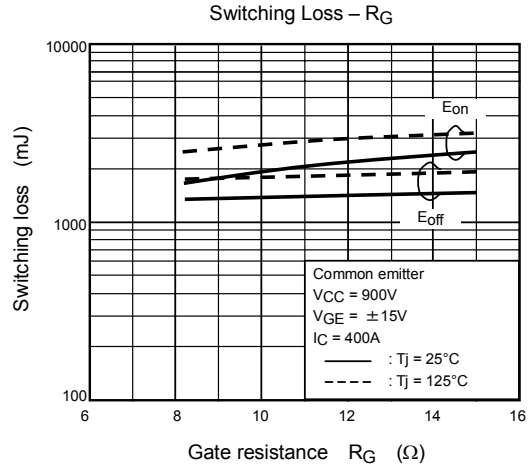
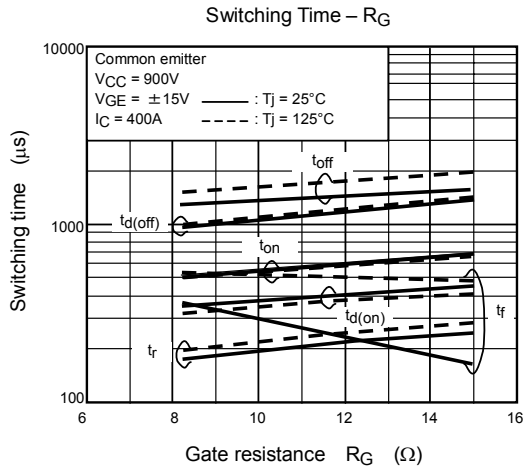
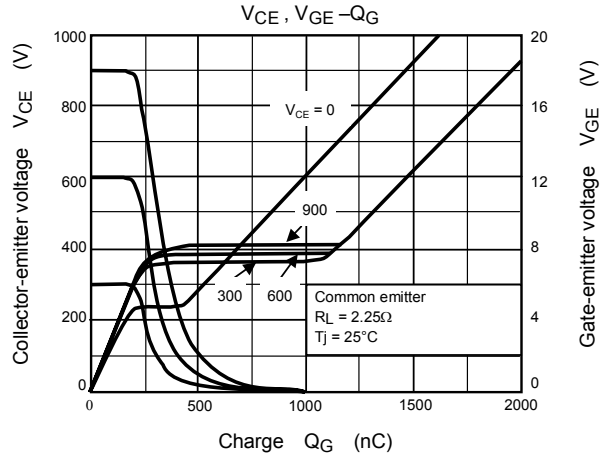
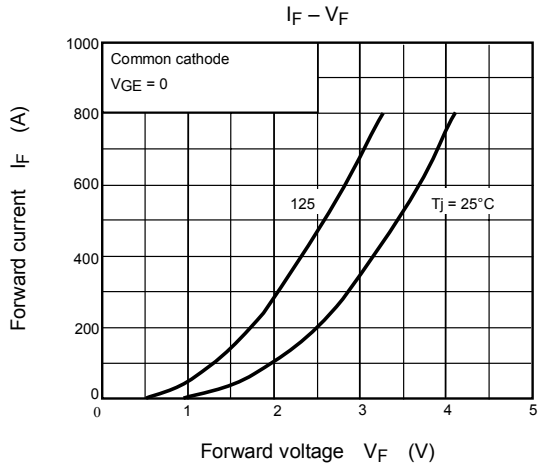

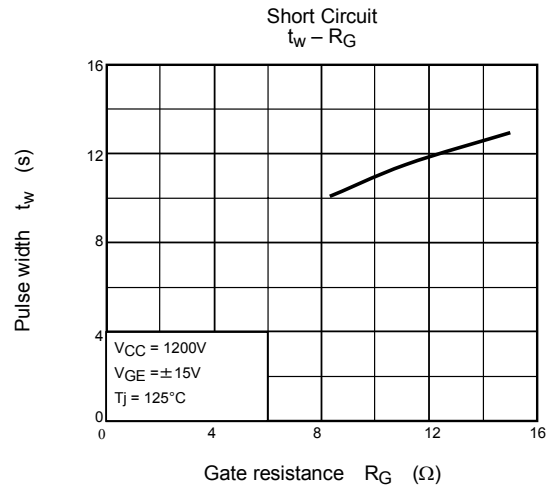
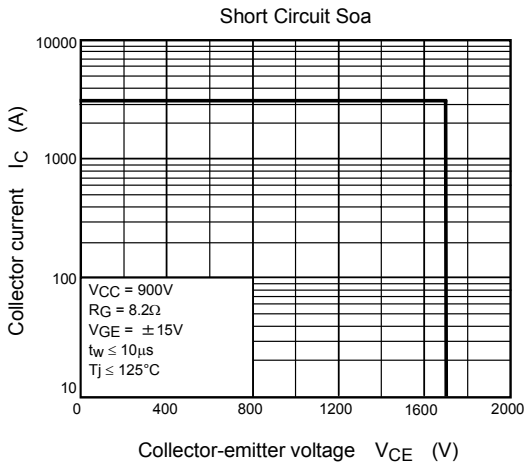
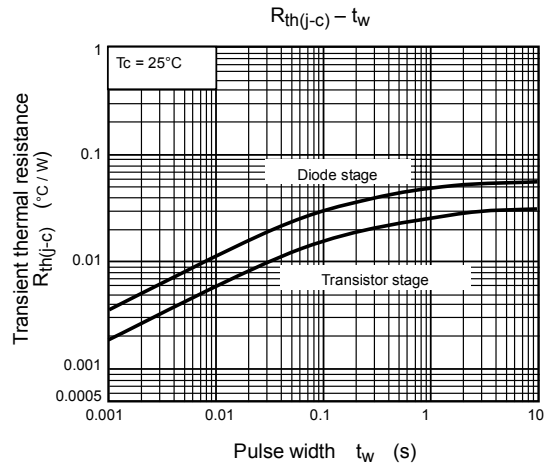
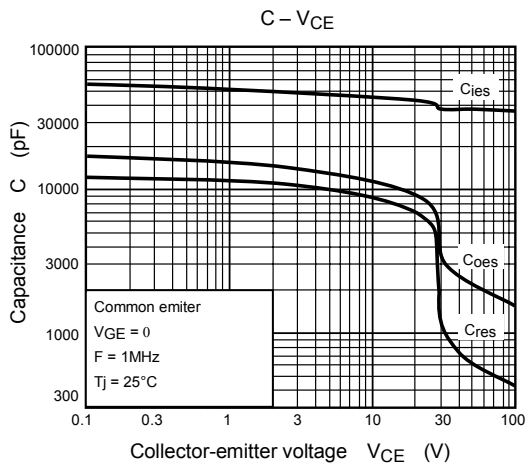
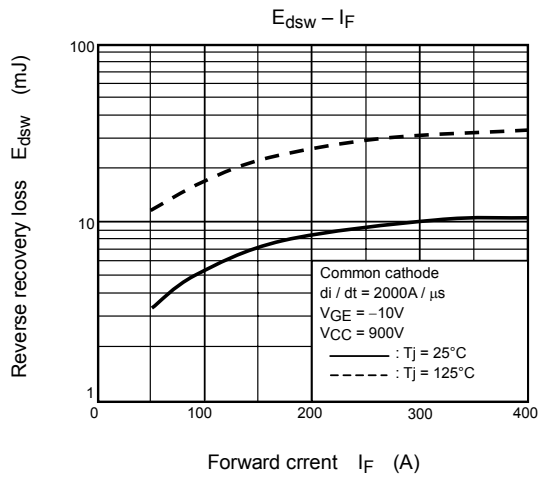
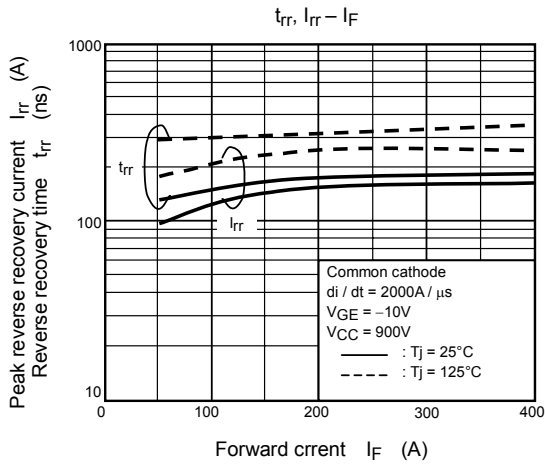

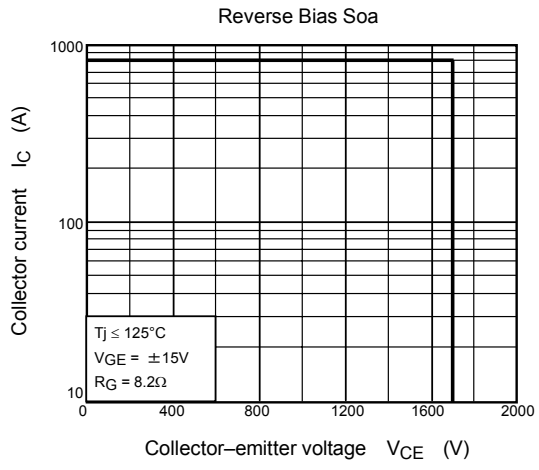

<V_{CE(sat)} Rank>

V_{CE(sat)}

Rank Symbol	Min.	Max.
29	2.6	2.9
30	2.7	3.0
31	2.8	3.1
32	2.9	3.2
33	3.0	3.3
34	3.1	3.4

<V_F Rank>

V_F

Rank Symbol	Min	Max.
G	2.5	2.8
H	2.7	3.0
I	2.9	3.2
J	3.1	3.4
K	3.3	3.6
L	3.5	3.8
M	3.7	4.0
N	3.9	4.2

<Mark Position>

