

AS3688

Flexible Lighting Management (Charge Pump, DCDC Step Up, Current Sink, ADC, LDO)

1 General Description

The AS3688 is a highly-integrated CMOS Power and Lighting Management Unit to supply power to LCD-and cameramodules in mobile telephones, and other 1-cell Li+ or 3-cell NiMH powered devices.

The AS3688 incorporates one low-power, low-dropout regulator (LDO), one Step Up DC/DC Converter for white backlight LEDs, one high-power Charge Pump for camera flash LEDs, one Analog-to-Digital Converter, support for up to 11 current sinks, a two wire serial interface, and control logic all onto a single device. Output voltages and output currents are fully programmable.

The AS3688 is a successor to the austriamicrosystems AS3681 with several additional features (Charge Pump Automatic Up Switching, Extended timer features, autonomous logarithmic PWM dimming, LED pattern generator, DCDC step up overvoltage protection, improved Charge Pump and a fourth high current sink).

2 Key Features

New features of the AS3688 compared to the AS3681 are written in **boldface italics**.

- Programmable High-Performance Regulator
 - Low-Noise LDO (1.85 to 3.4V, 150mA)
 - **Default off** after Power-up
 - 3 μ A Quiescent Current in Standby
 - Programmable via Serial Interface
- High-Efficiency Step Up DC/DC Converter
 - Up to 25V/50mA for White LEDs
 - Programmable Output Voltage with External Resistors and Serial Interface
 - **Overvoltage Protection**
 - **0.1 Ω** Shunt Resistor
- High-Efficiency High-Power Charge Pump
 - 1:1, 1:1.5, and 1:2 Mode
 - **Automatic Up Switching (can be disabled and 1:2 mode can be blocked)**
 - Output Current up to 400mA / **900mA pulsed**
 - Efficiency up to 95%
 - **Very Low effective Resistance** (0.5 Ω typ. 1 Ω max. in 1:1 mode, **1.4 Ω typ. 2 Ω max.** in 1:1.5)
 - Only 4 External Capacitors Required: 2 x 1 μ F Flying Capacitors, 2 x 2.2 μ F
 - Supports LCD White Backlight LEDs,
 - Camera Flash White LEDs, and Keypad Backlight LEDs
- Supports up to **12** Current Sinks
 - **Four** Programmable (**8+1Bit**) from: **0.6mA to 300mA**

- Two High Voltage Programmable (**8-bit**) from: **0.15mA to 38.25mA**
- Three Programmable (**8-bit**) from: **0.15mA to 38.25mA** for RGB LEDs
- Three Programmable (**8-bit**) from: **0.15mA to 38.25mA** for General Purpose
- Programmable Hardware Control (Strobe, **and Preview** or PWM)
- Selectively Enable/Disable Current Sinks
- **Internal PWM Generation**
 - 8 Bit resolution
 - Logarithmic up/down dimming
- **Led Pattern Generator**
- **Autonomous driving for Fun RGB LED**
- 10-bit Successive Approximation ADC
 - 27 μ s Conversion Time
 - **Four** Selectable Inputs: GPIO0-3
 - **Internal Temp. Measurement**
 - **Support for Light Sensor, including a adjustable current source (0-15 μ A)**
- **Support for automatic LED function testing (open and shorted LEDs can be identified)**
- **Support for external Temperature Sensor for high current LED protection (CURR3x)**
- Strobe Timeout protection
- **Up to 1600ms**
- **Three different timing modes**
- **TXMask function (reduce current during Strobe) selectable on pin GPIO1**
- Four General Purpose Inputs/Outputs
- GPIO0-2 Input/Output, **GPI only Input**
 - Digital Input, Digital Output, and Tristate
 - Programmable Pull-Up, and Pull-Down
 - **GPI** can be used as Flash Strobe
 - **GPIO2 can be used for Preview Mode**
 - **GPIO0/2 can be used for PWM input**
- Negative or High-Voltage Charge Pump
 - Regulated Output Voltage, Programmable by Dual Resistors e.g. -6V, 10mA for OLED or \pm 15V, 5mA for TFT
 - \pm 5% Accuracy
- Standby LDO always on
 - Regulated 2.5V max. output 10mA
 - 3 μ A Quiescent Current
- Wide Battery Supply Range: 3.0 to 5.5V
- Two Wire Serial Interface Control
- Overcurrent and Thermal Protection
- Package **QFN32 5x5mm or CSP 3x3mm**

3 Application

Power- and lighting-management for mobile telephones and other 1-cell Li+ or 3-cell NiMH powered devices.

4 Block Diagram

Figure 1 – Application Diagram of the AS3688: Option shown: Step up DCDC converter, RGB Current Sinks

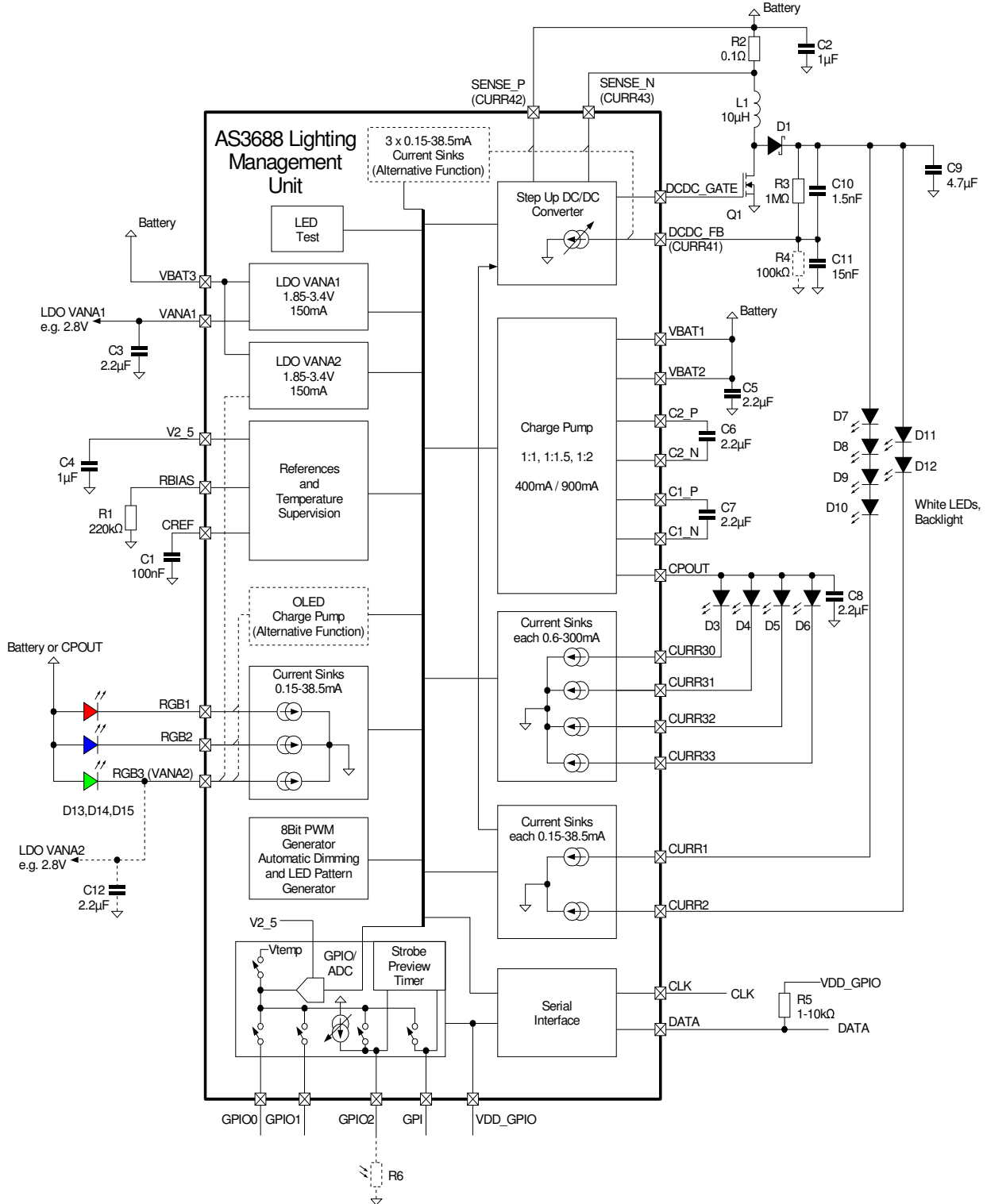

Copyright

Copyright © 1997-2005, austriamicrosystems AG, Schloss Premstaetten, 8141 Unterpremstaetten, Austria-Europe. Trademarks Registered ®. All rights reserved. The material herein may not be reproduced, adapted, merged, translated, stored, or used without the prior written consent of the copyright owner.

All products and companies mentioned are trademarks of their respective companies.

Disclaimer

Devices sold by austriamicrosystems AG are covered by the warranty and patent identification provisions appearing in its Term of Sale. austriamicrosystems AG makes no warranty, express, statutory, implied, or by description regarding the information set forth herein or regarding the freedom of the described devices from patent infringement. austriamicrosystems AG reserves the right to change specifications and prices at any time and without notice. Therefore, prior to designing this product into a system, it is necessary to check with austriamicrosystems AG for current information. This product is intended for use in normal commercial applications. Applications requiring extended temperature range, unusual environmental requirements, or high reliability applications, such as military, medical life-support or life-sustaining equipment are specifically not recommended without additional processing by austriamicrosystems AG for each application.

The information furnished here by austriamicrosystems AG is believed to be correct and accurate. However, austriamicrosystems AG shall not be liable to recipient or any third party for any damages, including but not limited to personal injury, property damage, loss of profits, loss of use, interruption of business or indirect, special, incidental or consequential damages, of any kind, in connection with or arising out of the furnishing, performance or use of the technical data herein. No obligation or liability to recipient or any third party shall arise or flow out of austriamicrosystems AG rendering of technical or other services.

Contact Information

Headquarters:

austriamicrosystems AG
Business Unit Communications
A 8141 Schloss Premstätten, Austria
T. +43 (0) 3136 500 0
F. +43 (0) 3136 5692
info@austriamicrosystems.com

For Sales Offices, Distributors and Representatives, please visit:

www.austriamicrosystems.com

austriamicrosystems – a leap ahead