

SAW Resonator

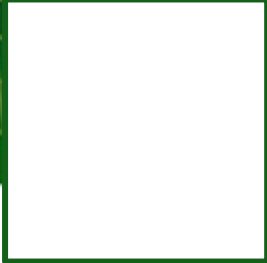
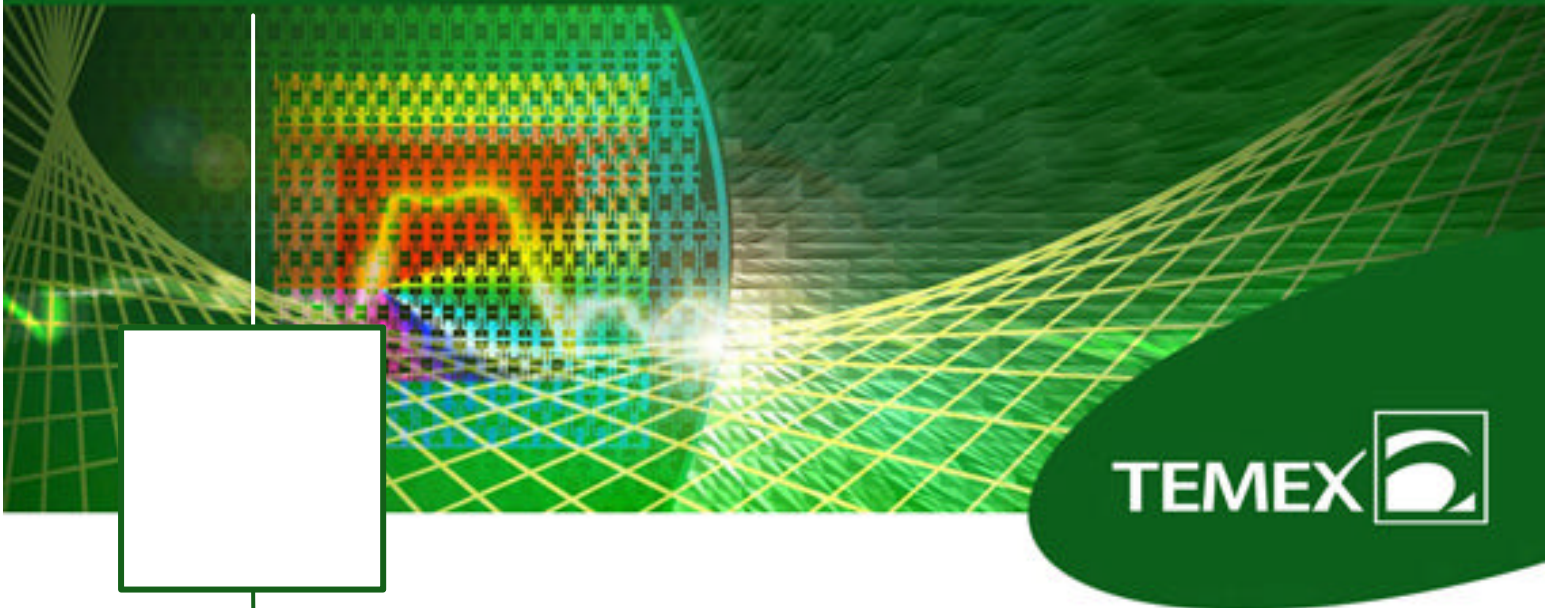

FR W337

SAW Resonator – Remote Control
Specification (Rev 2)

▣ Features.....	P01
▣ Package Drawing & Pin out.....	P01
▣ Technical Characteristics	P02
▣ LC Model	P02
▣ Typical Applications	P03
▣ Nominal Response.....	P03
▣ Maximum Ratings.....	P04
▣ Marking & Packaging	P04

FR W337

SAW Resonator – Remote Control

Specification (Rev.2)

September 25th, 2005

Features

- SAW Resonator
- Quartz frequency stabilization
- Tolerance $\pm 75\text{kHz}$
- Ceramic package for Surface Mounted Technology

Package Drawing & Pin out

The product is in conformance with the European RoHs Regulation 2002/95.

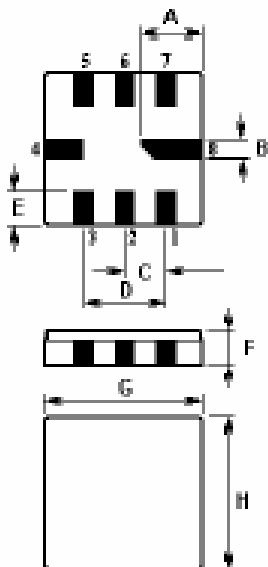

Dimensions (unit: mm)

Dimension	Value (mm)
A	2.8
B	0.6
C	1.27
D	2.54
E	1.2
F	1.35
G	5.0
H	5.0

Pin Configuration

Input	2
Output	6
Case ground	4, 8

FR W337

SAW Resonator – Remote Control

Specification (Rev.2)

September 25th, 2005

Technical Characteristics

Reference Temperature : +25°C

Electrical Parameters	Unit	Minimum	Typical ⁽¹⁾	Maximum
Center Frequency f_c	MHz	-	433.92	-
Tolerance from f_c	kHz	-	-	±75
Insertion Loss	dB	-	1.2	1.8
Quality Factor				
Unloaded Q (Q_u)		-	9.2	-
50 W Loaded Q (Q_l)		-	1.2	-
Temperature Stability				
Turnover Temperature (T_0)	°c	25	-	55
Turnover Frequency (f_0)	kHz	-	f_c	-
Frequency Temperature Coefficient (FTC)	ppm/°c ²	-	0.037	-
Frequency Aging Absolute Value during the first Year $ f_A $	ppm/yr	-	< 10	
DC Insulation Resistance Between any Two Pins	MΩ	1.0	-	-
RF Equivalent RLC Model				
Motional Resistance (R_M)	Ω	-	15	23
Motional Inductance (L_M)	μH	-	50.6419	-
Motional Capacitance (C_M)	fF		2.6592	-
Shunt Static Capacitance (C_0)	pF	2.3	2.6	2.9

LC Model

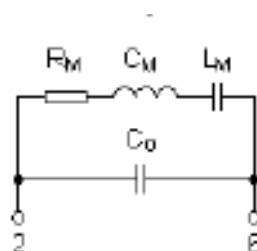

FR W337

SAW Resonator – Remote Control

Specification (Rev.2)

September 25th, 2005

Typical Applications

Low Power Transmitter

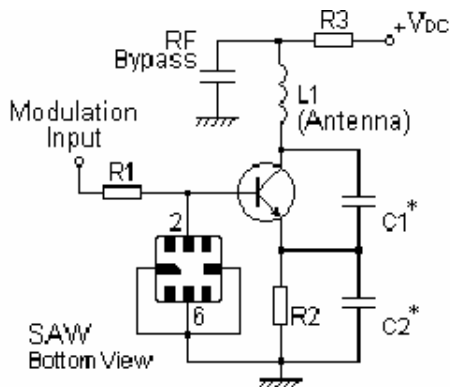

Local Oscillator

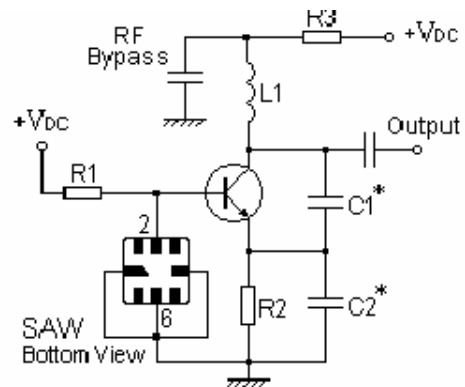

Nominal Frequency Response (Measurements)

Frequency Response

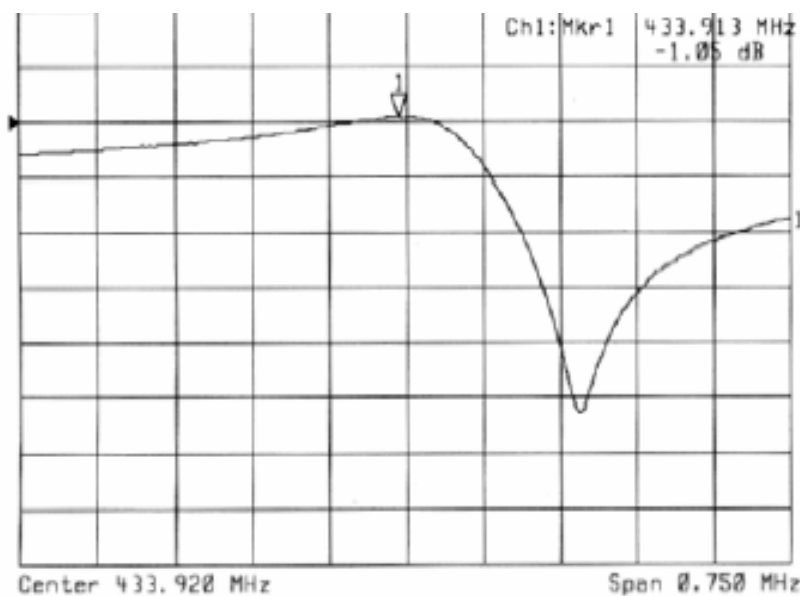

FR W337

SAW Resonator – Remote Control

Specification (Rev.2)

September 25th, 2005

Maximum Ratings

Storage Temperature Range	°C	[-40°C ; +85°C]
Operating Temperature	°C	[-10°C ; +60°C]
DC voltage between any two pins	V	± 30
CW RF Power Dissipation	dBm	0

Marking

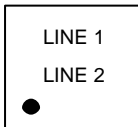

Line 1: "FR NNNN" is the reference to Temex Part number

Line 2: RYWWZZ is the date code as:

R: Partner identifier.

Y: last digit of the year.

WW: number of week in the year

ZZ: Lot number in the week (from AA to ZZ).

Packaging

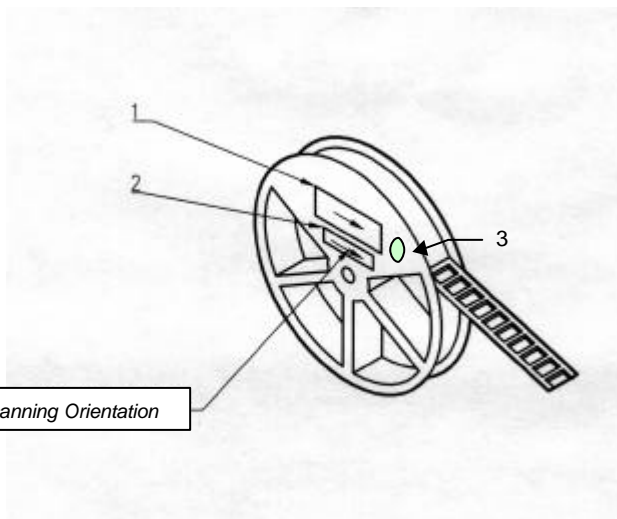

- 1 – Temex Label
- 2 – ESD Prevention Label
- 3 – Pb Free Label