

### POWER MANAGEMENT

#### Description

The SC900A is a highly integrated power management device for low power portable applications. The device contains five adjustable low-dropout linear regulators (LDOs) with CMOS pass-devices as well as a band-gap reference, I<sup>2</sup>C interface, and DACs to control the output voltages.

Many features of the SC900A are programmable through the I<sup>2</sup>C interface. These include the ability to independently turn on any combination of the five regulators. All five of the LDO output voltages are programmable in 50mV steps from 1.45V to 3.00V for LDOs A and B, and from 1.75V to 3.30V for LDOs C, D and E. Each LDO can have an active shutdown or nonactive shutdown program option through the interface. There is also a reset monitor flag that is associated with LDOA. In addition, the device has a separate programmable power good monitor flag that activates when one or more LDOs go out of regulation.

The SC900A offers significant quiescent current and space savings to the system designer by sharing reference and biasing among five LDOs. The small and thermally efficient 20-lead MLPQ package make it ideal for use in portable products where minimizing layout area is critical.

#### Features

- ◆ Five LDO regulators in one package
- ◆ I<sup>2</sup>C interface with multiple device capability
- ◆ Independent I<sup>2</sup>C enable/disable of LDOs
- ◆ Independent I<sup>2</sup>C control of output voltages
- ◆ Low thermal impedance of 40 °C per watt
- ◆ 150mV dropout at 150mA
- ◆ Input range from 2.7V to 5.5V
- ◆ Programmable power good flag
- ◆ Minimal number of external components
- ◆ Over temperature protection
- ◆ Small 4mm x 4mm 20-lead MLPQ package
- ◆ Small input/output filter capacitors
- ◆ Programmable VOUT range -
  - 1.45V to 3.00V for LDOs A and B
  - 1.75V to 3.30V for LDOs C, D and E

#### Applications

- ◆ Palmtop/Laptop computers
- ◆ Personal Digital Assistants
- ◆ Cellular telephones
- ◆ Battery-powered equipment
- ◆ High efficiency linear power supplies

#### Typical Application Circuit

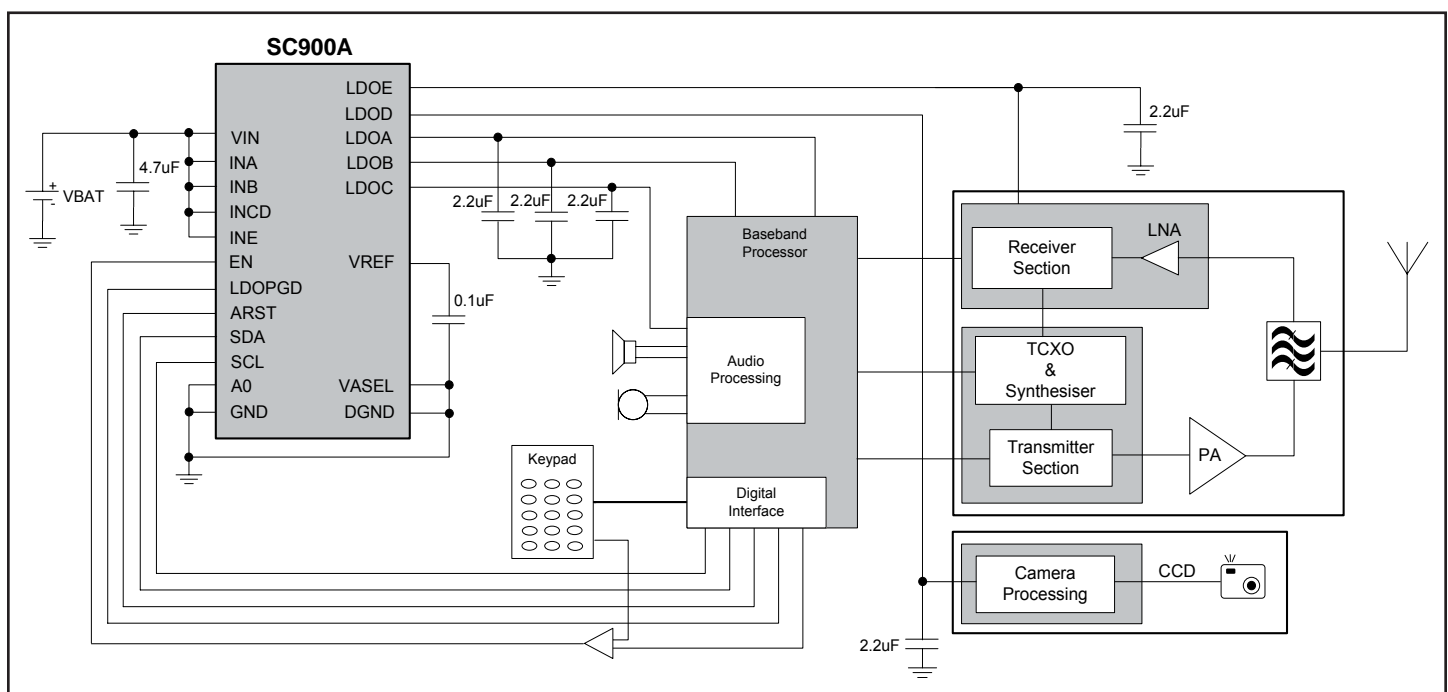

**POWER MANAGEMENT**
**Absolute Maximum Ratings**

Exceeding the specifications below may result in permanent damage to the device or device malfunction. Operation outside of the parameters specified in the Electrical Characteristics section is not implied.

Parameter	Symbol	Maximum	Units
Input Supply Voltage	$V_{IN}$	-0.3 to +7	V
Digital Input Voltage	$V_{DIG}$	-0.3 to $V_{IN} + 0.3$	V
Operating Ambient Temperature Range	$T_A$	-40 to +85	°C
Operating Junction Temperature Range	$T_J$	-40 to +125	°C
Peak IR Flow Temperature	$T_{LEAD}$	260	°C
Storage Temperature	$T_{STG}$	-60 to +150	°C
Thermal Impedance Junction to Ambient <sup>(1)</sup>	$\theta_{JA}$	40	°C/W
ESD Protection Level <sup>(2)</sup>	ESD	2	kV

(1) Calculated from package in still air, mounted to 3" x 4.5", 4 layer FR4 PCB with thermal vias under the exposed pad as per JESD51 standards.

(2) Tested according to JEDEC standard JESD22-A114-B.

**Electrical Characteristics**

Unless otherwise noted  $V_{IN} = 3.7V$ ,  $T_A = -40$  to  $+85^\circ C$ . Typical values are at  $T_A = +25^\circ C$ .

Parameter	Symbol	Conditions	Min	Typ	Max	Units
<b>General</b>						
Supply Voltage	$V_{IN}$	All outputs < $V_{IN}$ - dropout	2.7		5.5	V
Quiescent Current Shutdown	$I_{Q-SHUTDOWN}$				10	$\mu A$
Supply Bypass Capacitor	$C_{VCC}$	Per input pin		1		$\mu F$
<b>Digital Inputs</b>						
Digital Input Voltage	$V_{IL}$				0.4	V
	$V_{IH}$		1.6			V
Digital Input Current	$I_{DIG}$		-0.2		0.2	$\mu A$
<b>Digital Outputs</b>						
Digital Output Voltage <sup>(1)</sup>	$V_{OL}$	$I_{SINK} = 1.2mA$ , $V \geq 1.8V$		2	10	%LDOB
	$V_{OH}$	$I_{SOURCE} = 0.5mA$ , $V \geq 1.8V$	90	98		%LDOB
<b>Referencing and Biasing Circuitry</b>						
Quiescent Current Reference	$I_{Q-REF}$			25		$\mu A$
Reference Voltage	$V_{REF}$			1.227		V
$V_{REF}$ Start-Up Time	$I_{VREF}$	$C_{VREF} = 100nF$		15		ms
$V_{REF}$ Bypass Capacitor	$C_{VREF}$			0.1		$\mu F$

**POWER MANAGEMENT**
**Electrical Characteristics (Cont.)**

Parameter	Symbol	Conditions	Min	Typ	Max	Units
<b>LDO Regulators</b>						
Quiescent Supply Current	$I_Q$	All LDOs active in default states		190	360	$\mu\text{A}$
Quiescent Supply Current at Start-Up	$I_{QSUP}$	LDO A, B, C active in default states $V_{OUT} + 0.5V < V_{IN} < 5.5V$		125		$\mu\text{A}$
Current Limit	$I_{LIM}$		250	410	650	mA
Bypass Capacitor	$C_{BYP}$	Ceramic, low ESR	2.2			$\mu\text{F}$
<b>LDO Regulator A (Core Supply)</b>						
Output Voltage Accuracy	$VOA_A$	$1.45V \leq V_{OUT} \leq 3.00V$ $V_{OUT} + 0.2V \leq V_{IN} \leq 5.5V$ $I_{OUT} = 1\text{mA}, T_A = 25^\circ\text{C}$	-3		+3	%
Output Voltage Accuracy at 2.80V (DAC = 11011)	$VOAS_A$	$I_{OUT} = 1\text{mA}$	-2		+2	%
Output Voltage Accuracy at 1.80V (DAC = 00011)		$I_{OUT} = 1\text{mA}, T_A = 25^\circ\text{C}$	-3		+3	%
Output Voltage Accuracy at 2.80V (DAC = 11011)		$V_{OUT} + 0.5V \leq V_{IN} \leq 5.5V,$ $I_{OUT} = 200\text{mA}$	-3.5		+3.5	%
Maximum Output Current	$IOMAX_A$		200			mA
Default Setting: ON	$VO_{A-HI}$	VASEL - High		2.80		V
	$VO_{A-LO}$	VASEL - Low		1.80		V
Line Regulation at 1.8V, 2.8V	$LINEREG_A$	$I_{OUT} = 1\text{mA}, V_{OUT} + 0.2V < V_{IN} < 5.5V$		2.5	12	mV
Load Regulation at 1.8V, 2.8V	$LOADREG_A$	$1\text{mA} < I_{OUT} < 200\text{mA}$		-3	-20	mV
Dropout Voltage	$V_{DA}$	$V_{OUT} = 3.0V, I_{OUT} = 200\text{mA}$		200	250	mV
Power Supply Rejection Ratio	$PSRR_A$	$f = 10\text{Hz} - 1\text{kHz}, C_{BYP} = 0.1\mu\text{F},$ $I_{OUT} = 50\text{mA},$ $2.5V \leq V_{OUT} \leq 3.0V$		60		dB
Output Voltage Noise <sup>(2)</sup>	$e_{n-A}$	$f = 10\text{Hz} - 100\text{kHz}, I_{OUT} = 50\text{mA},$ $C_{VREF} = 0.1\mu\text{F}, C_{OUT} = 2.2\mu\text{F},$ $2.5V \leq V_{OUT} \leq 3.0V$		45		$\mu\text{V}_{RMS}$
<b>LDO Regulator B (DIGITAL I/O SUPPLY)</b>						
Output Voltage Accuracy	$VOA_B$	$1.45V \leq V_{OUT} \leq 3.00V$ $V_{OUT} + 0.15V \leq V_{IN} \leq 5.5V$ $I_{OUT} = 1\text{mA}, T_A = 25^\circ\text{C}$	-3		+3	%
Output Voltage Accuracy at 2.80V (DAC = 11011)	$VOAS_B$	$I_{OUT} = 1\text{mA}$	-2		+2	%
		$V_{OUT} + 0.5V \leq V_{IN} \leq 5.5V,$ $I_{OUT} = 150\text{mA}$	-3.5		+3.5	%
Maximum Output Current	$IOMAX_B$		150			mA

**POWER MANAGEMENT**
**Electrical Characteristics (Cont.)**

Parameter	Symbol	Conditions	Min	Typ	Max	Units
<b>LDO Regulator B (DIGITAL I/O SUPPLY) (Cont.)</b>						
Default Setting: ON	$VO_B$			2.80		mV
Line Regulation at 2.8V	$LINEREG_B$	$I_{OUT} = 1mA, V_{OUT} + 0.15V < V_{IN} < 5.5V$		2.5	12	mV
Load Regulation at 2.8V	$LOADREG_B$	$1mA < I_{OUT} < 150mA$		-3	20	mV
Dropout Voltage	$V_{DB}$	$V_{OUT} = 3.0V, I_{OUT} = 150mA$		150	190	mV
Power Supply Rejection Ratio	$PSRR_B$	$f = 10Hz - 1kHz, C_{BYP} = 0.1\mu F,$ $I_{OUT} = 50mA,$ $2.5V \leq V_{OUT} \leq 3.0V$		60		dB
Output Voltage Noise <sup>(2)</sup>	$e_{n-B}$	$f = 10Hz - 100kHz, I_{OUT} = 50mA,$ $C_{VREF} = 0.1\mu F, C_{OUT} = 2.2\mu F,$ $2.5V \leq V_{OUT} \leq 3.0V$		45		$\mu V_{RMS}$
<b>LDO Regulator C</b>						
Output Voltage Accuracy	$VOA_C$	$1.75V \leq V_{OUT} \leq 3.30V$ $V_{OUT} + 0.15V \leq V_{IN} \leq 5.5V$ $I_{OUT} = 1mA, T_A = 25^\circ C$	-3		+3	%
Output Voltage Accuracy at 2.90V (DAC = 10111)	$VOAS_C$	$I_{OUT} = 1mA$	-2		+2	%
		$V_{OUT} + 0.5V \leq V_{IN} \leq 5.5V,$ $I_{OUT} = 150mA$	-3.5		+3.5	%
Maximum Output Current	$IOMAX_C$		150			mA
Default Setting: ON	$VO_C$			2.90		V
Line Regulation at 2.90V	$LINEREG_C$	$I_{OUT} = 1mA, V_{OUT} + 0.15V < V_{IN} < 5.5V$		2.5	12	mV
Load Regulation at 2.90V	$LOADREG_C$	$1mA < I_{OUT} < 150mA$		-3	-20	mV
Dropout Voltage	$V_{DC}$	$V_{OUT} = 3.3V, I_{OUT} = 150mA$		150	190	mV
Power Supply Rejection Ratio	$PSRR_C$	$f = 10Hz - 1kHz, C_{BYP} = 0.1\mu F,$ $I_{OUT} = 50mA,$ $2.5V \leq V_{OUT} \leq 3.3V$		60		dB
Output Voltage Noise <sup>(2)</sup>	$e_{n-C}$	$f = 10Hz - 100kHz, I_{OUT} = 50mA,$ $C_{VREF} = 0.1\mu F, C_{OUT} = 2.2\mu F,$ $2.5V \leq V_{OUT} \leq 3.3V$		55		$\mu V_{RMS}$
<b>LDO Regulator D</b>						
Output Voltage Accuracy	$VOA_D$	$1.75V \leq V_{OUT} \leq 3.30V$ $V_{OUT} + 0.15V \leq V_{IN} \leq 5.5V$ $I_{OUT} = 1mA, T_A = 25^\circ C$	-3		+3	%
Output Voltage Accuracy at 3.10V (DAC = 10111)	$VOAS_D$	$I_{OUT} = 1mA$	-2		+2	%
		$V_{OUT} + 0.5V \leq V_{IN} \leq 5.5V,$ $I_{OUT} = 150mA$	-3.5		+3.5	%

**POWER MANAGEMENT**
**Electrical Characteristics (Cont.)**

Parameter	Symbol	Conditions	Min	Typ	Max	Units
<b>LDO Regulator D (Cont.)</b>						
Maximum Output Current	IOMAX <sub>D</sub>		150			mA
Default Setting: OFF	VO <sub>D</sub>			3.10		V
Line Regulation at 3.10V	LINEREG <sub>D</sub>	I <sub>OUT</sub> = 1mA, V <sub>OUT</sub> + 0.15V < V <sub>IN</sub> < 5.5V		2.5	12	mV
Load Regulation at 3.10V	LOADREG <sub>D</sub>	1mA < I <sub>OUT</sub> < 150mA		-3	-20	mV
Dropout Voltage	V <sub>DD</sub>	V <sub>OUT</sub> = 3.3V, I <sub>OUT</sub> = 150mA		150	190	mV
Power Supply Rejection Ratio	PSRR <sub>D</sub>	f = 10Hz - 1kHz, C <sub>BYP</sub> = 0.1mF, I <sub>OUT</sub> = 50mA, 2.5V ≤ V <sub>OUT</sub> ≤ 3.3V		60		dB
Output Voltage Noise <sup>(2)</sup>	e <sub>n-D</sub>	f = 10Hz - 100kHz, I <sub>OUT</sub> = 50mA, C <sub>VREF</sub> = 0.1μF, C <sub>OUT</sub> = 2.2μF, 2.5V ≤ V <sub>OUT</sub> ≤ 3.3V		55		μV <sub>RMS</sub>
<b>LDO Regulator E</b>						
Output Voltage Accuracy	VOA <sub>E</sub>	1.75V ≤ V <sub>OUT</sub> ≤ 3.30V V <sub>OUT</sub> + 0.15V ≤ V <sub>IN</sub> ≤ 5.5V I <sub>OUT</sub> = 1mA, T <sub>A</sub> = 25°C	-3		+3	%
Output Voltage Accuracy at 3.10V (DAC = 10111)	VOAS <sub>E</sub>	I <sub>OUT</sub> = 1mA	-2		+2	%
		V <sub>OUT</sub> + 0.5V ≤ V <sub>IN</sub> ≤ 5.5V, I <sub>OUT</sub> = 150mA	-3.5		+3.5	%
Maximum Output Current	IOMAX <sub>E</sub>		150			mA
Default Setting: OFF	VO <sub>E</sub>			3.10		V
Line Regulation at 3.10V	LINEREG <sub>E</sub>	I <sub>OUT</sub> = 1mA, V <sub>OUT</sub> + 0.15V < V <sub>IN</sub> < 5.5V		2.5	12	mV
Load Regulation at 3.10V	LOADREG <sub>E</sub>	1mA < I <sub>OUT</sub> = 150mA		-3	-20	mV
Dropout Voltage	V <sub>DE</sub>	V <sub>OUT</sub> = 3.3V, I <sub>OUT</sub> = 150mA		150	190	mV
Power Supply Rejection Ratio	PSRR <sub>E</sub>	f = 10Hz - 1kHz, C <sub>BYP</sub> = 0.1μF, I <sub>OUT</sub> = 50mA, 2.5V ≤ V <sub>OUT</sub> ≤ 3.3V		60		dB
Output Voltage Noise <sup>(2)</sup>	e <sub>n-E</sub>	f = 10Hz - 100kHz, I <sub>OUT</sub> = 50mA, C <sub>VREF</sub> = 0.1μF, C <sub>OUT</sub> = 2.2μF, 2.5V ≤ V <sub>OUT</sub> ≤ 3.3V		55		μV <sub>RMS</sub>
<b>A RESET</b>						
Reset Threshold	RESET <sub>THLD</sub>			77		%
Reset Active Timeout Delay	t <sub>RD</sub>	Delay in default state	75	100	125	ms
<b>LDO POWER GOOD</b>						
PGOOD Threshold	PGOOD <sub>THLD</sub>			77		%
PGOOD Active Timeout Delay	t <sub>PG</sub>	Delay in default state	75	100	125	ms

Notes:

1) Digital outputs are powered from LDOB, so LDOB must be active for operation of LDOPGD and ARST.

2) Below 2.5V: becomes digital regulator.

**POWER MANAGEMENT**
**Electrical Characteristics (Cont.)**

Parameter	Symbol	Conditions	Min	Typ	Max	Units
<b>I<sup>2</sup>C Interface</b>						
Interface complies with slave mode I <sup>2</sup> C interface as described by Philips I <sup>2</sup> C specification version dated January 2000.						
Digital Input Voltage	V <sub>IL</sub>				0.4	V
	V <sub>IH</sub>		1.6			V
SDA Output Low Level		I <sub>DIN</sub> (SDA) = 3mA			0.4	V
		I <sub>DIN</sub> (SDA) = 6mA			0.6	V
Digital Input Current	I <sub>DG</sub>		-0.2		0.2	μA
I/O Pin Capacitance	C <sub>IN</sub>			10		pF
<b>I<sup>2</sup>C Timing</b>						
Clock Frequency	f <sub>SCL</sub>			400	440	kHz
SCL Low Period	t <sub>LOW</sub>		1.3			μs
SCL High Period	t <sub>HIGH</sub>		0.6			μs
Data Hold Time	T <sub>HD_DAT</sub>		0			μs
Data Setup Time	T <sub>SU_DAT</sub>		100			μs
Setup Time for Repeated Start Condition	T <sub>SU_STA</sub>		0.6			μs
Hold Time for Repeated Start Condition	T <sub>HD_STA</sub>		0.6			μs
Setup Time for Stop Condition	T <sub>SU_STO</sub>		0.6			μs
Bus-Free Time Between STOP and START	t <sub>BUF</sub>		1.3			μs

**POWER MANAGEMENT**

**Pin Configuration**

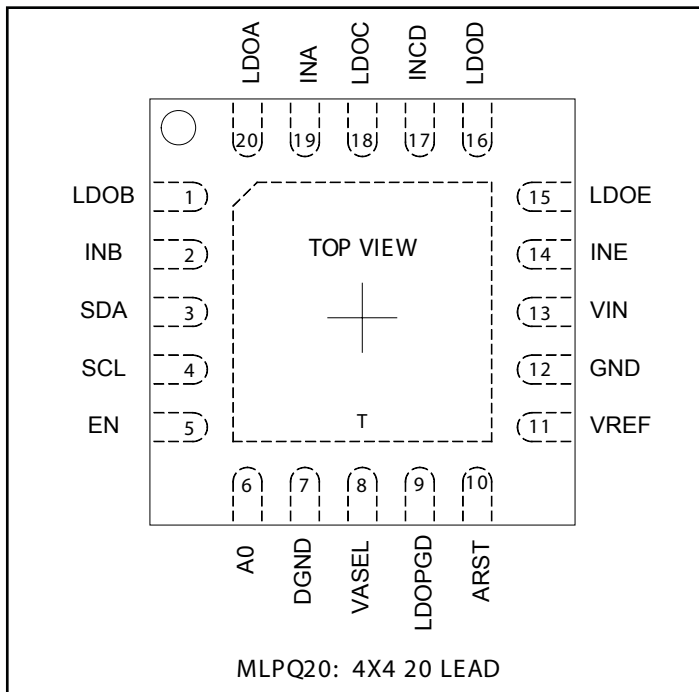

**Ordering information**

DEVICE	PACKAGE
SC900AMLTRT <sup>(1)(2)</sup>	MLPQ20L
SC900AEVB	Evaluation Board

Notes:

(1) Available in tape and reel only. A reel contains 3,000 devices.

(2) Available in lead-free package only. Device is WEEE and RoHS compliant.

**POWER MANAGEMENT**
**Pin Descriptions**

Pin#	Pin Name	Pin Function
1	LDOB	LDO B output.
2	INB	Input supply for the digital system logic and the LDO B pass transistor.
3	SDA	Bidirectional open drain digital I/O pin. I <sup>2</sup> C serial data.
4	SCL	Digital input. I <sup>2</sup> C serial clock.
5	EN	Digital input. High to enable part. Low to disable part (sleep mode). Note I <sup>2</sup> C control is active only when part is enabled.
6	A0	One bit address for connecting two SC900A devices on to the system through the I <sup>2</sup> C interface.
7	DGND	Digital ground.
8	VASEL	LDO A selection default voltage. Tie this pin to ground for 1.8V or INB for 2.8V.
9	LDOPGD	Digital output. State change indicates that one of four LDO output voltages (A, C, D or E) is out of spec. Note, desired state of pin is programmable through the I <sup>2</sup> C interface.
10	ARST	Digital output. State change indicates LDO A output voltage is out of spec. Note, desired state of pin is programmable through the I <sup>2</sup> C interface.
11	VREF	Bandgap reference output voltage. Connect at least 0.1 $\mu$ F to ground ( $C_{VREF} \geq 0.1\mu F$ ).
12	GND	Analog ground.
13	VIN	Analog supply voltage.
14	INE	Input supply for the LDO E pass transistor.
15	LDOE	LDO E output.
16	LDOD	LDO D output.
17	INCD	Input supply for the LDO C and LDO D pass transistors.
18	LDOC	LDO C output.
19	INA	Input supply for the LDO A pass transistor.
20	LDOA	LDO A output.
T	Thermal Pad	Thermal Pad for heatsinking purposes. Connect to ground plane using multiple vias. Not connected internally.



POWER MANAGEMENT

Block Diagram

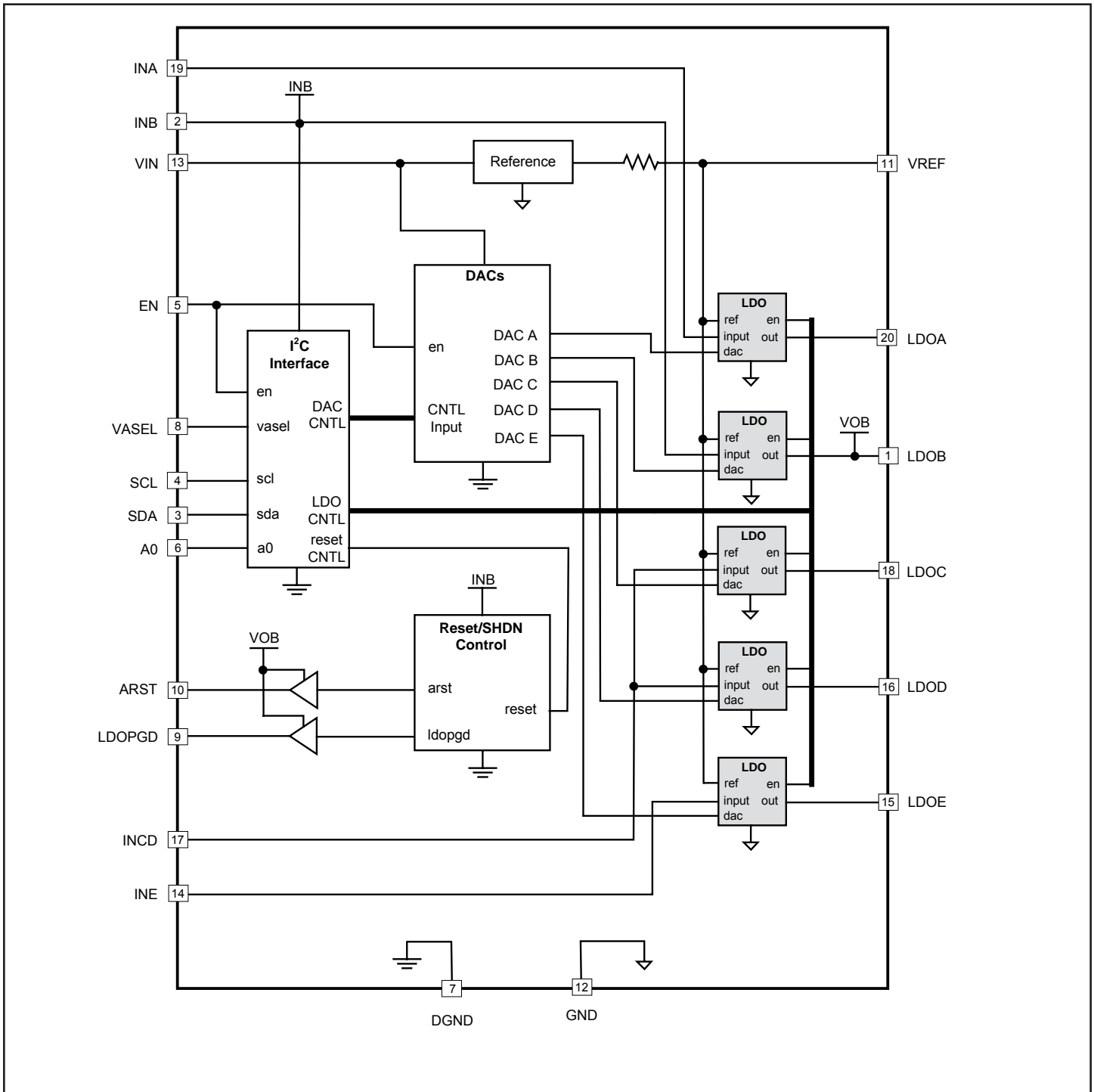

## POWER MANAGEMENT

### Applications Information

#### General Description

Each of the five low-dropout linear regulators (LDOs) can be independently enabled or disabled and their output voltages can each be set by an independent DAC. These controls can be accessed through the I<sup>2</sup>C serial port. There are five 8-bit volatile registers in the SC900A; one for each LDO (registers A,B,C,D,E). In addition there is one common reset and power good control register and one on/off control register. The active shutdown circuitry can be accessed through each LDO register (refer to the section “Active Shutdown” on page 11 for more information).

At power-up, the register contents are reset to their default values and the ARST for LDO A has a default start-up delay of 100ms. At any time the part can be put into its lowest power state (shutdown) by pulling the EN pin low. Whenever the EN pin is forced low, the previous settings are lost and the part requires reprogramming to return to the desired state. When EN is pulled high, the device starts up in the default state. A detailed description of the protocol used to load the registers with data is described in the section entitled “Using the I<sup>2</sup>C Interface” on page 14.

#### VIN and Enable Pin

The V<sub>IN</sub> supply must be ≥ 2.7V before the EN pin can be asserted. This means that the EN pin should not be tied to V<sub>IN</sub> so that it does not reach a logic high level before the input supply reaches 2.7V.

#### LDOA (Core Supply)

LDOA is intended to be used as the core supply. It has an output current capability of 200mA and a dedicated reset signal ARST. INA is the dedicated input supply for this regulator.

#### LDOB (Digital I/O Supply)

INB supplies power for the internal I<sup>2</sup>C interface and other digital I/O functions, while LDOB supplies power for ARST and LDOPGD output ports (see Block Diagram). Therefore it is imperative that LDOB be operational to make use of ARST and LDOPGD. If LDOB is turned off by the on/off control register, these output ports will not function.

#### LDO RESET Control Register: ARST Pin

There are two functions that can be programmed, defining the ARST pin action:

- Set the polarity of the reset signal
- Set the reset clear delay time in milliseconds

As soon as the LDOA output voltage falls below its programmed value, the ARST pin is asserted. The polarity of the ARST pin can be set to active high or active low during a reset condition, by bit 6 of the LDO Reset Control Register. Once the error condition is resolved (output rises to the programmed value), a delay is initiated before the ARST pin is cleared. The delay is programmable by bits 0-1 of the LDO Reset Control Register. The Default delay time is 100ms, and the delay can be programmed for 0, 50, 100, or 150ms.

#### LDOPGD Pin

There are three functions that can be programmed to define the LDOPGD pin action:

- Set which LDOs are to be monitored for power good
- Set the polarity of the power good signal
- Set the power good delay time in milliseconds

Bits 4 and 5 of the LDO Reset Control Register select which LDO or LDOs are monitored. LDO C, D and E can be monitored independently or LDOs A, C, D, and E can be monitored collectively. The polarity of the LDOPGD pin can be set to active high or active low by bit 7 of the LDO Reset Control Register. As soon as any of the selected LDO output voltages which are monitored falls within spec, the LDO power good (LDOPGD) pin is asserted. Once the LDO output power is stable (output rises to the programmed value), a delay is initiated before the LDOPGD pin is set. The delay is programmable by bits 2 and 3 of the LDO Reset Control Register. The default delay is 100ms, and this delay can be programmed to 0, 50, 100, or 150ms.

**POWER MANAGEMENT**
**Applications Information (Cont.)**
**Active Shutdown**

The shutdown control bits determine how the on-chip active shutdown switches behave. Each LDO register uses bit 5 of the LDO output voltage data byte to control the shutdown behavior. When the active shutdown bit is enabled (set to 1), the capacitance on the LDO output will be discharged by an on-chip FET after the LDO is disabled. When the active shutdown bit is disabled (set to 0), the output capacitance on the LDO output is discharged by the load. The default active shutdown state for all LDOs is on.

**ON/OFF Control Register**

Each individual LDO may be turned on or off by accessing the ON/OFF control register. LDOs are turned on by setting their respective on/off bit to 1. Likewise, they can be turned off by setting the on/off bit to 0. This allows for on/off control with a single write command. If the enable (EN) pin is high and data is written to the LDO voltage registers, the LDO outputs will go to the voltage prescribed by the Output Voltage Code bits (0-4). Data will not be lost when toggling the on/off bit from 0 to 1. However, if the EN pin is forced low, all circuitry in the device is disabled. All programmed information is lost when the enable bit is subsequently pulled high.

**VASEL Pin**

The VASEL pin sets the default voltage of LDO A, the core supply. When this pin is set to  $V_{IN}$ , the default voltage is 2.80V. When this pin is set to GND, the default voltage is 1.80V. The voltage can be changed from its default state after start up by writing to the LDO voltage code register.

**Device Addressing**

Following a start condition, the master must output the address of the slave it is accessing. The most significant six bits of the slave are the device type identifier (ID). For the SC900A this is fixed at 000100[B]. The next significant bit addresses a particular device. A system can have up to two SC900A devices on the bus. The two addresses are defined by the state of the A0 input (see Figure 1).

DEVICE TYPE IDENTIFIER						DEVICE ADDRESS	R/W
0	0	0	1	0	0	Pin A0 to GND = 0 Pin A0 to VIN = 1	X

**Figure 1 - Slave Address Structure**

When the A0 pin is tied to GND, device 1 has an address of 0 and the combination of device type ID and address is 0x08H. When the A0 pin is tied to  $V_{IN}$ , device 2 has an address of 1 and the combination of device type ID and address is 0x09H.

The last bit of the slave address defines the operation to be performed. When set to a one a read operation is selected; when set to a zero a write operation is selected. Following a start condition, the SC900A monitors the SDA line comparing the slave address being transmitted with its slave address (device type ID and state of A0 input). Upon a correct compare the SC900A outputs an acknowledge on the SDA line. Depending on the state of the R/W bit, the SC900A will execute a read or write operation.

**Protection Circuitry**

The SC900A provides protection circuitry that prevents the device from operating in an unspecified state. These include Under Voltage Lockout Protection, Over-temperature Protection and Short-circuit Protection.

**Under Voltage Lockout**

The SC900A provides an Under Voltage Lockout (UVLO) circuit to protect the device from operating in an unknown state if the input voltage supply is too low. When the battery voltage drops below the UVLO threshold, the LDOs are disabled. As the battery voltage increases above the hysteresis level, the LDOs are re-enabled into their previous states, provided ENABLE has remained high. If ENABLE goes low, the SC900A will shut down.

**Over Temperature Protection**

The SC900A provides an internal Over-temperature (OT) protection circuit that monitors the internal junction temperature. When the temperature exceeds the OT threshold, the OT protection disables all the LDO outputs. As the junction temperature drops below the hysteresis level the OT protection re-enables all the LDOs in their previous states, provided ENABLE has remained high. If ENABLE goes low, the SC900A will shut down.

**Short-Circuit Protection**

Each LDO output has short-circuit protection. If a short is applied to any output, the output voltage will drop and the output current will be limited to the short circuit current until the short is removed.

**POWER MANAGEMENT**
**Applications Information (Cont.)**
**Layout Considerations**

Layout is straightforward if you use the Gerber files on page 21 as a reference. Notice that the input voltage feed to the SC900A is on the bottom of the board and vias connect this voltage track to the top of the board and then to the SC900A itself. The input bypass can be one 4.7µF capacitor, two 3.3µF capacitors, three 2.2µF capacitors or five 1µF capacitors. The determining factor is how much copper is available on the input voltage feed track and

how much room is available. If the input voltage track is very thin, then use five 1µF capacitors placed very close to the input pins of the SC900A. If the input track is fairly thick, then you can use a single 4.7µF capacitor at the beginning of the voltage feed track since a wider track has less inductance per inch. The SC900AEVB has five 1µF capacitors, but these can be replaced with one 4.7µF in place of C1 and opens in place of C9, C14, C15, and C16 (see page 20 for details).

**LDO Reset Control Logic Table (Defaults are in Bold)**

Register Name	Register Address	Bit 7	Bit 6	Bit 5	Bit 4	Bit 3	Bit 2	Bit 1	Bit 0					
LDO A	0x00	X	X	Active Shutdown 1 = ON 0 = OFF	Output Voltage Codes Table A for LDOs A & B Table B for LDOs C, D & E									
LDO B	0x01													
LDO C	0x02													
LDO D	0x03													
LDO E	0x04													
LDO Reset Control	0x05	LDOPGD Pin Reset Polarity Bit	ARST Pin Reset Polarity Bit	LDOPGD Monitor Logic Bits		LDOPGD Delay Bits		LDO (A) Reset Delay Bits						
On/Off Control Register	0x06	X	X	X	ON/OFF Control LDO E		ON/OFF Control LDO D		ON/OFF Control LDO C		ON/OFF Control LDO B		ON/OFF Control LDO A	
					1	0	1	0	1	0	1	0	1	0
					ON	OFF	ON	OFF	ON	OFF	ON	OFF	ON	OFF

**LDO Reset Control Logic Table (Defaults are in Bold)**

Bit 7	Result	Bit 6	Result	Bit 5	Bit 4	Result	Bit 3	Bit 2	Result	Bit 1	Bit 0	Result
LDOPGD Pin Polarity		ARST Pin Polarity		LDOPGD Monitor Logic			LDOPGD Delay			ARST Delay		
0	High: Power Fail Low: Power Good	0	High: Reset Low: Power Good	0	0	<b>LDOs A, C, D &amp; E Good</b>	0	0	150ms	0	0	150ms
1	<b>High: Power Good</b> <b>Low: Power Fail</b>	1	<b>High: Power Good</b> <b>Low: Reset</b>	0	1	LDO E Good	0	1	<b>100ms</b>	0	1	50ms
				1	0	LDO C Good	1	0	50ms	1	0	<b>100ms</b>
				1	1	LDO D Good	1	1	0ms	1	1	0ms

Note:

Digital outputs are powered from INB, additionally LDOB must be on for operation of LDOPGD and ARST.

**SC900A Slave Address**

DEVICE TYPE IDENTIFIER						DEVICE ADDRESS	R/W
0	0	0	1	0	0	A0	X

**POWER MANAGEMENT**
**Applications Information (Cont.)**
**Output Voltage Code Bits:**

A 5-bit linear DAC controls the output voltage of each LDO. The DAC and error-amp gain are scaled so that the LSB size at the output is 50mV. Output voltage can be set by writing the proper code to the desired LDO register. See Table A for the bitcodes and their corresponding voltages for LDOs A and B, and Table B for the bitcodes and corresponding voltages for LDOs C, D and E.

**Table A - LDO Output Voltage Control Settings for LDOs A and B**

BIT 4	BIT 3	BIT 2	BIT 1	BIT 0	LDO Output Voltage
0	0	0	0	0	1.45V
0	0	0	0	1	1.50V
0	0	0	1	0	1.55V
0	0	0	1	1	1.60V
0	0	1	0	0	1.65V
-	-	-	-	-	-
-	-	-	-	-	-
1	1	1	1	0	2.95V
1	1	1	1	1	3.00V

**Table B - LDO Output Voltage Control Settings for LDOs C, D and E**

BIT 4	BIT 3	BIT 2	BIT 1	BIT 0	LDO Output Voltage
0	0	0	0	0	1.75V
0	0	0	0	1	1.80V
0	0	0	1	0	1.85V
0	0	0	1	1	1.90V
0	0	1	0	0	1.95V
-	-	-	-	-	-
-	-	-	-	-	-
1	1	1	1	0	3.25V
1	1	1	1	1	3.30V

**POWER MANAGEMENT**

**Applications Information (Cont.)**

**Using the I<sup>2</sup>C Interface**

The SC900A is a read-write slave mode I<sup>2</sup>C device and complies with the Philips I<sup>2</sup>C standard version 2.1 dated January 2000. The SC900A has six user-accessible internal 8-bit registers. The I<sup>2</sup>C interface has been designed for program flexibility, in that once the slave address has been sent to the SC900A enabling it to be a slave transmitter/receiver, any register can be written to or read from independently of each other. While there is no auto increment/decrement capability in the SC900A I<sup>2</sup>C logic, a tight software loop can be designed to randomly access the next register independent of which register you have been accessing. The start and stop commands frame the datapacket and the repeat start condition is allowed if necessary.

**SC900A Limitations to the I<sup>2</sup>C Specifications**

Seven-bit addressing is required for communication with the SC900A; ten-bit addressing is not allowed. Any general call address will be ignored by the SC900A. Note that the SC900A is not CBUS compatible. Finally, the SC900A can operate in standard mode (100kbit/s) or fast mode (400kbit/s).

**Supported Formats**

**Direct Format - Write**

The simplest format for an I<sup>2</sup>C write is the direct format. After the start condition [S], the slave address is sent, followed by an eighth bit indicating a write. The SC900A I<sup>2</sup>C then acknowledges that it is being addressed, and the master responds with an 8-bit data byte consisting of the register address. The slave acknowledges and the master sends the appropriate 8-bit data byte. Once again the slave acknowledges and the master terminates the transfer with the stop condition [P].

**I<sup>2</sup>C Direct Format - Write**



- S: Start Condition
- W: Write = '0'
- A: Acknowledge (sent by slave)
- P: Stop condition
- Slave Address: 7 bit
- Register Address: 8 bit
- Data: 8 bit

**Combined Format - Read**

After the start condition [S], the slave address is sent, followed by an eighth bit indicating a write. The SC900A I<sup>2</sup>C then acknowledges that it is being addressed, and the master responds with an 8-bit data byte consisting of the register address. The slave acknowledges and the master sends the repeated start condition [Sr]. Once again the slave address is sent, followed by an eighth bit indicating a read. The slave responds with an acknowledge and the previously addressed 8-bit data byte. The master then sends a non-acknowledge (NACK). Finally the master terminates the transfer with the stop condition [P].

**I<sup>2</sup>C Combined Format - Read**



- S: Start Condition
- W: Write = '0'
- R: Read = '1'
- A: Acknowledge (sent by slave)
- NACK: Non-Acknowledge (sent by master)
- Sr: Repeated Start Condition
- P: Stop condition
- Slave Address: 7 bit
- Register Address: 8 bit
- Data: 8 bit

**POWER MANAGEMENT**

**Applications Information (Cont.)**

**Stop Separated Reads**

Another read format is available which is, in effect, an extension of the combined format read. This format allows a master to set up the register address pointer for a read and return to that slave some time later to read the data. After the start condition [S], the slave address is sent, followed by a write. The SC900A I<sup>2</sup>C then acknowledges that it is being addressed, and the master responds with the 8-bit register address. The master then sends a stop or restart condition, and may address another slave. Some time later the master sends a start or restart condition, and a valid slave address is sent, followed by a read. The SC900A I<sup>2</sup>C then acknowledges and returns the data at the register address location that had previously been set up.

**I<sup>2</sup>C Stop Separated Format - Read**

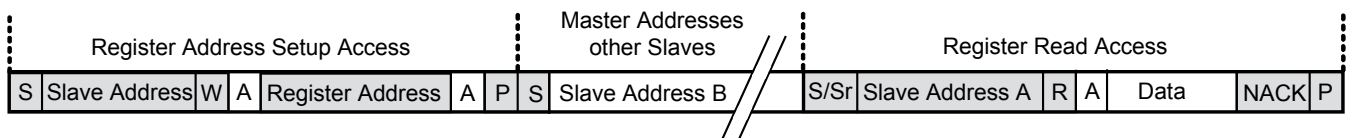

- S: Start Condition
  - W: Write = '0'
  - R: Read = '1'
  - A: Acknowledge (sent by slave)
  - NACK: Non-Acknowledge (sent by master)
  - Sr: Repeated Start Condition
  - P: Stop condition
- Slave Address: 7 bit
  - Register Address: 8 bit
  - Data: 8 bit

POWER MANAGEMENT

Timing Diagrams

ARST and LDOPGD Timing

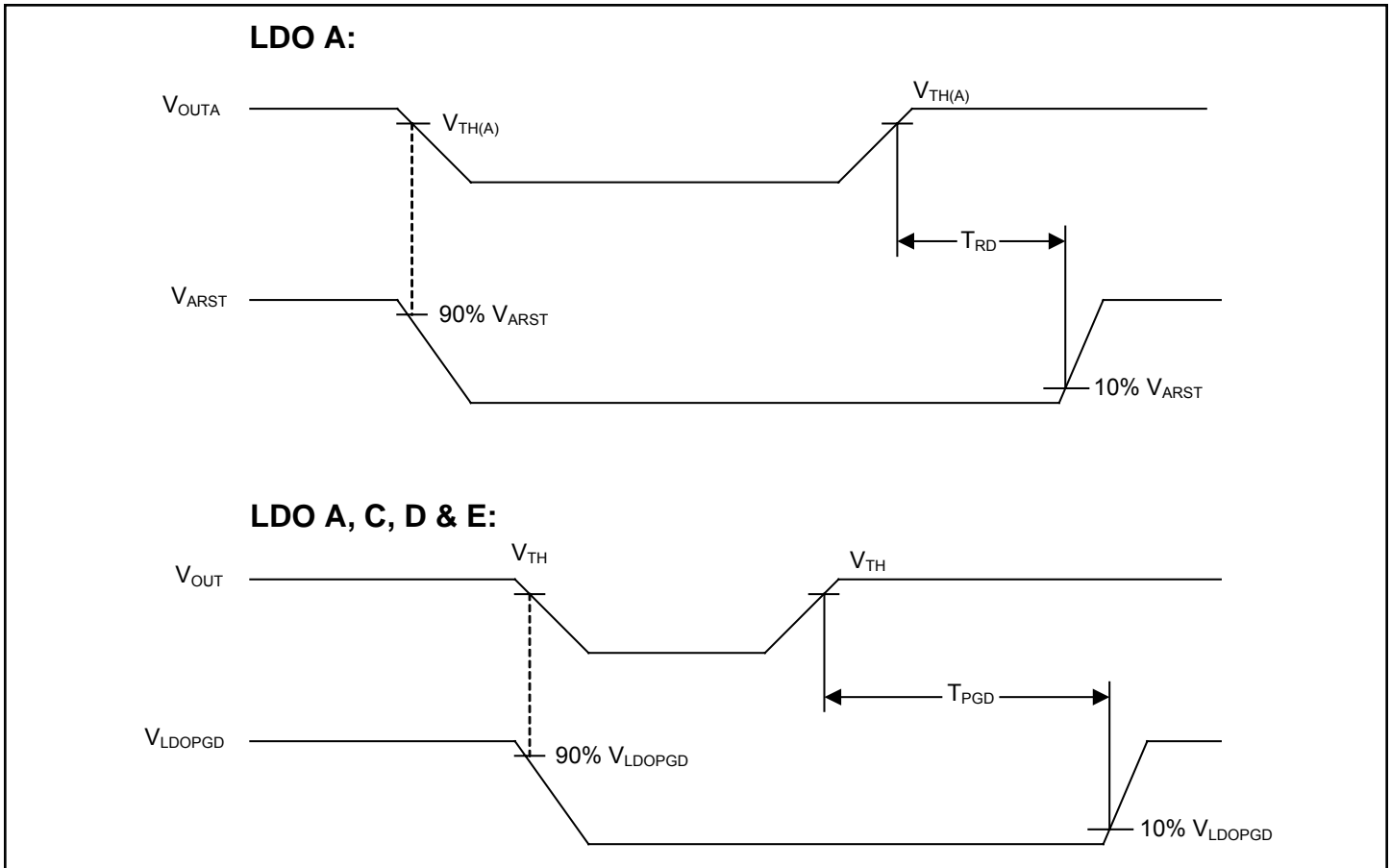

LDO On/Off Control via the I<sup>2</sup>C Interface

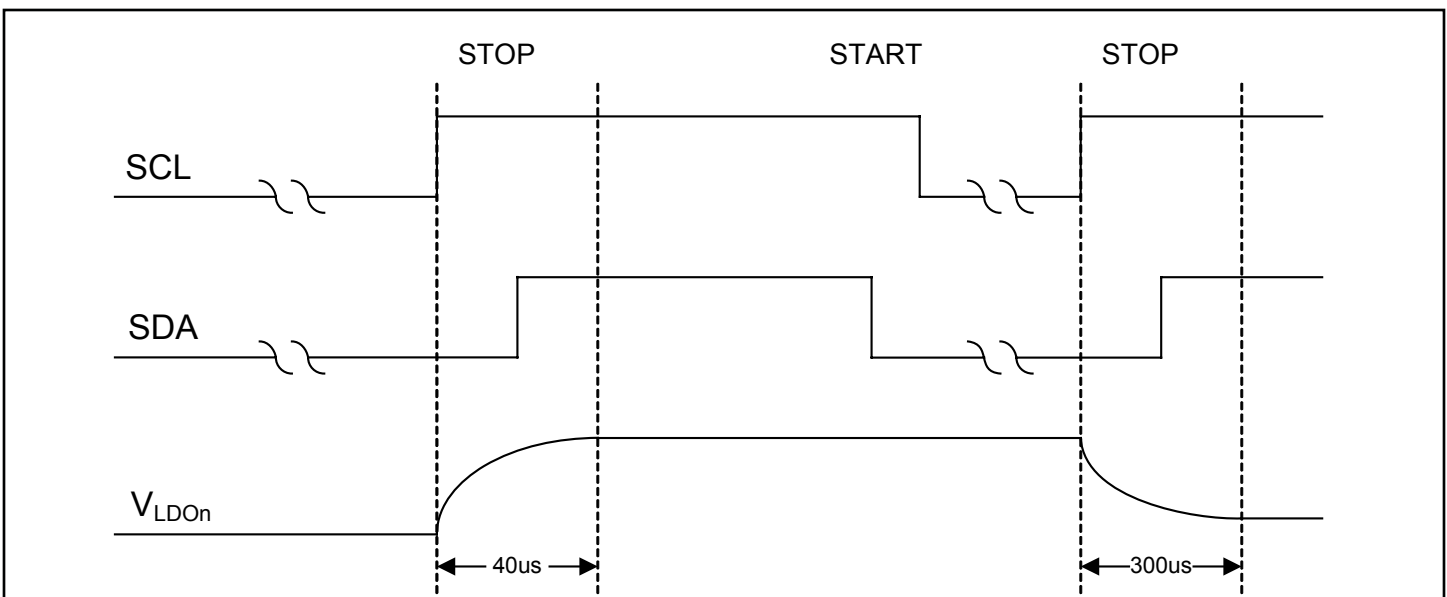



POWER MANAGEMENT

Timing Diagrams (Cont.)

Default Start-up, Shutdown Timing Diagram

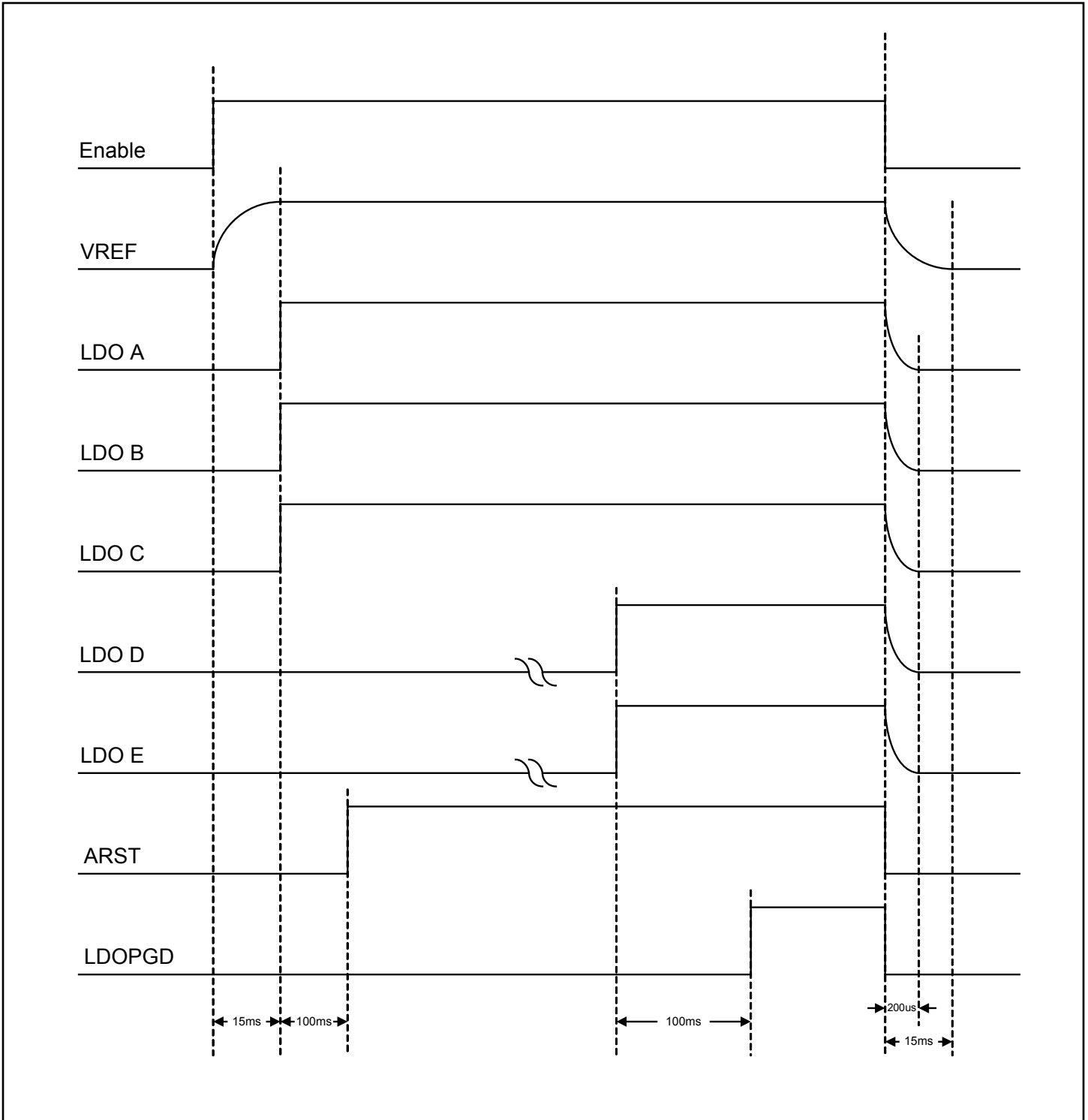

POWER MANAGEMENT

Typical Characteristics

Dropout Voltage (LDOA)

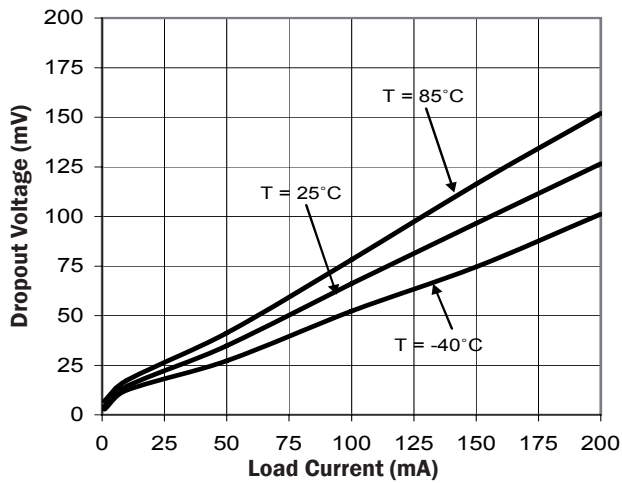

Dropout Voltage (LDOB-E)

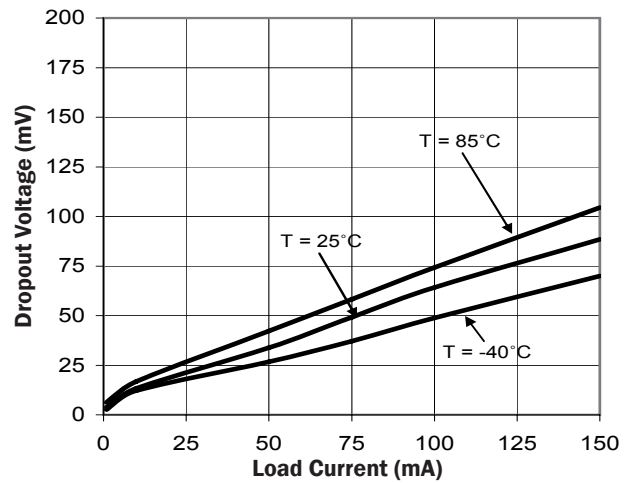

Load Regulation (LDOA)  
 $V_{IN} = 3.7V$

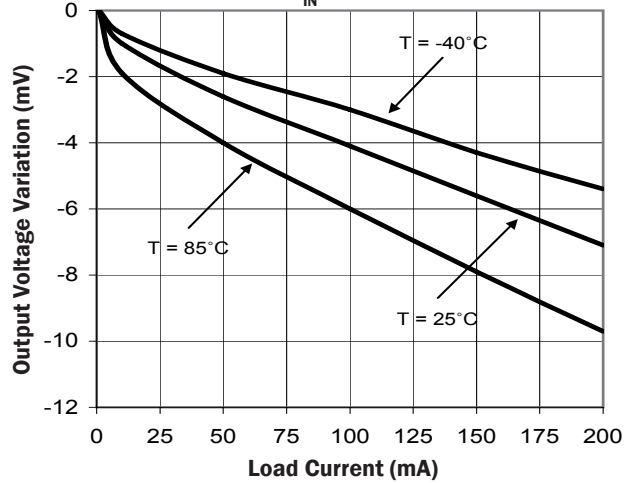

Load Regulation (LDOB-E)  
 $V_{IN} = 3.7V$

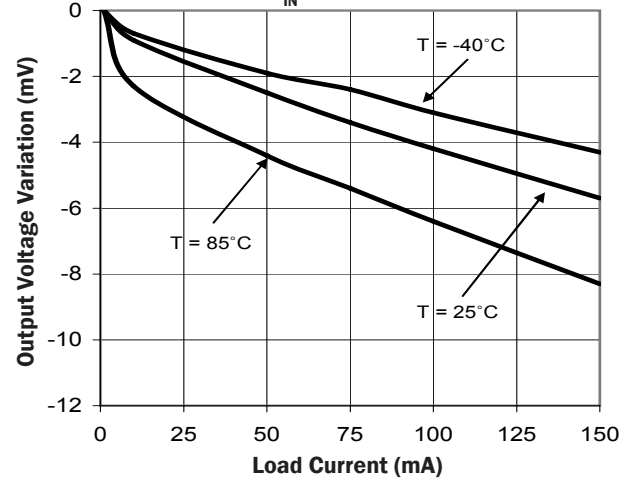

Line Regulation (LDOA-B)  
Load Current = 1mA

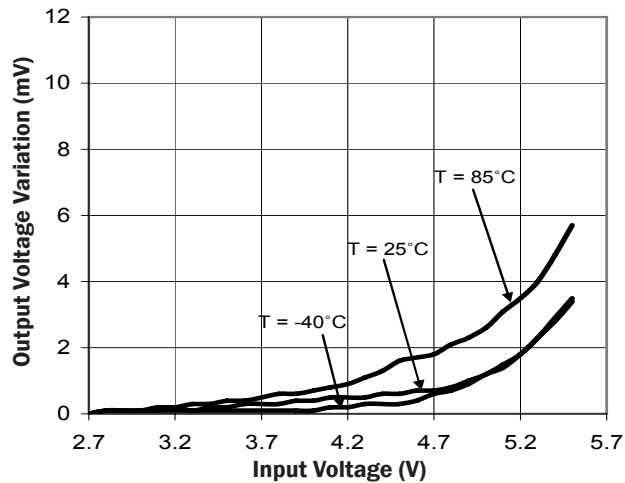

Line Regulation (LDOB-E)  
Load Current = 1mA

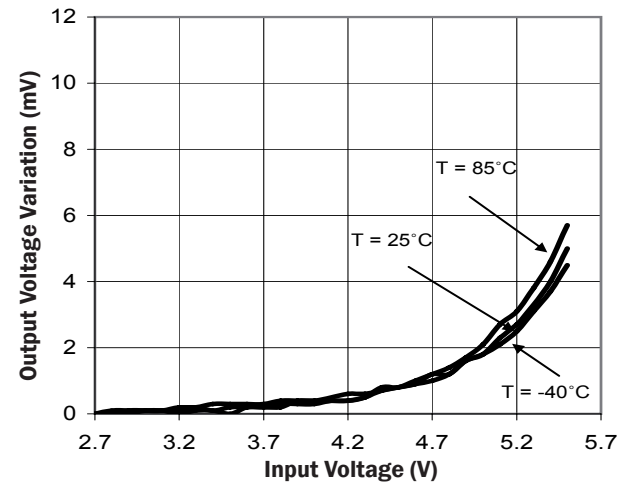

POWER MANAGEMENT

**Load Transient (LDOA-E)**  
 $V_{IN} = 3.7V, I_o = 10mA \text{ to } 150mA \text{ step}$

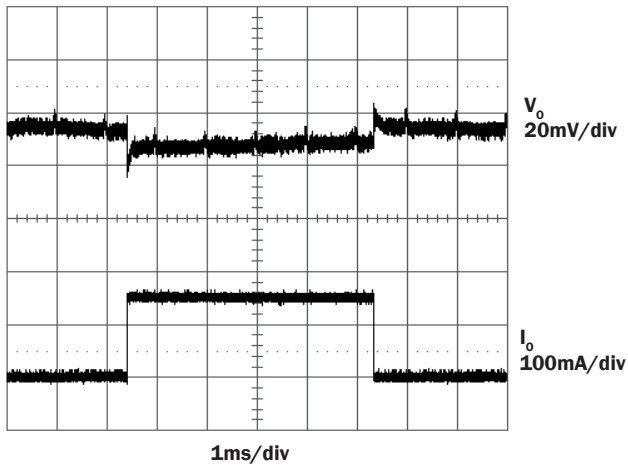

**Line Transient (LDOA-E)**  
 $V_{IN} = 3.7V, I_o = 150mA$

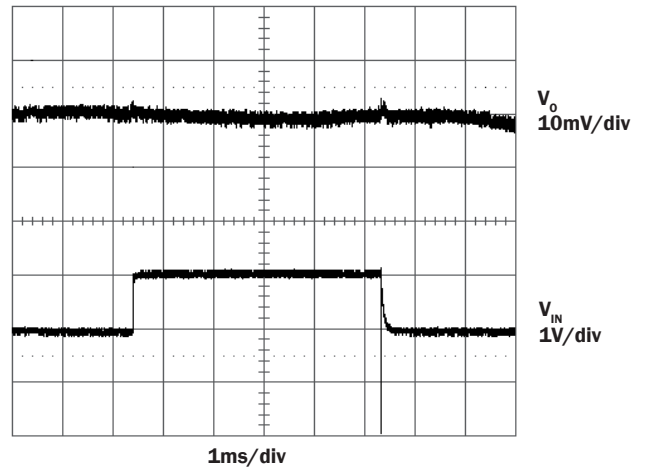

**Output Noise v Load Current (LDOA-B)**  
 $V_{IN} = 3.7V, V_o = 3V$

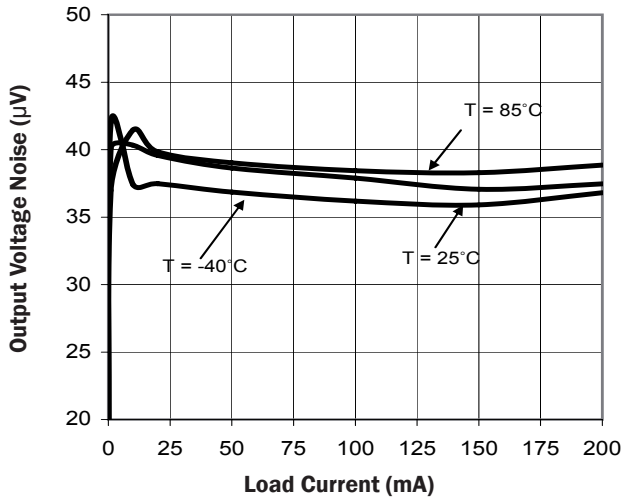

**Output Noise v Load Current (LDOC-E)**  
 $V_{IN} = 3.7V, V_o = 3.3V$

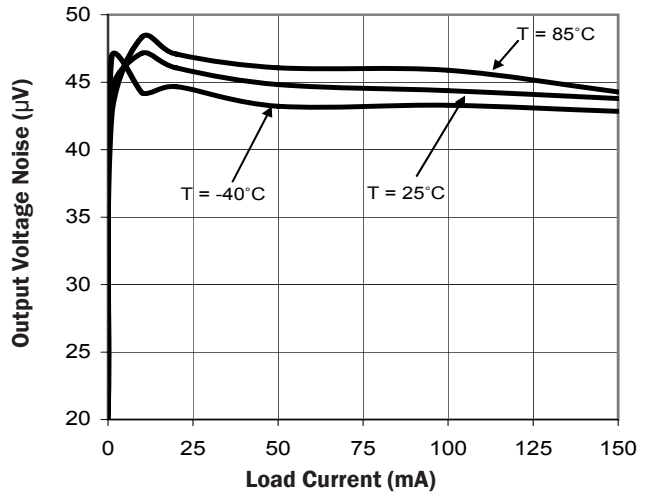

**PSRR v Frequency (LDOA-B)**  
 $V_{IN} = 3.7V, V_o = 3V$

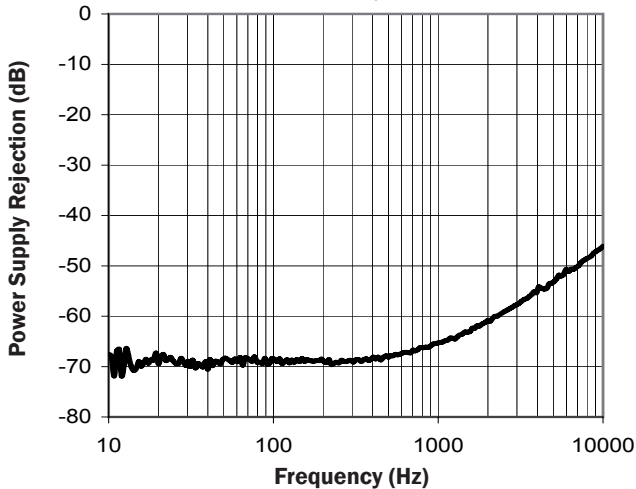

**PSRR v Frequency (LDOC-E)**  
 $V_{IN} = 3.7V, V_o = 3.3V$

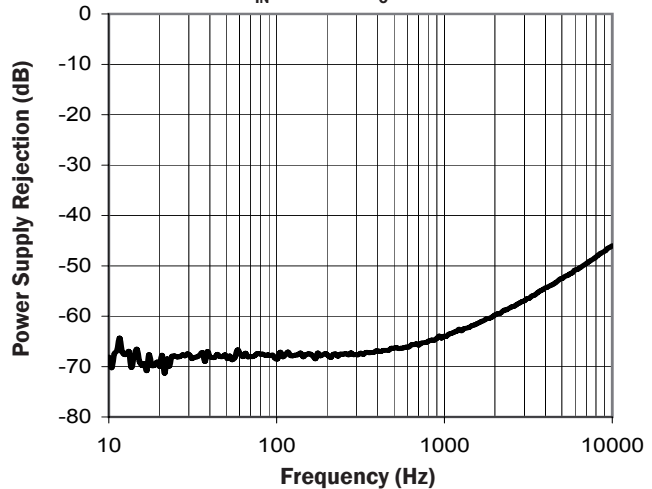

POWER MANAGEMENT

Evaluation Board Schematic

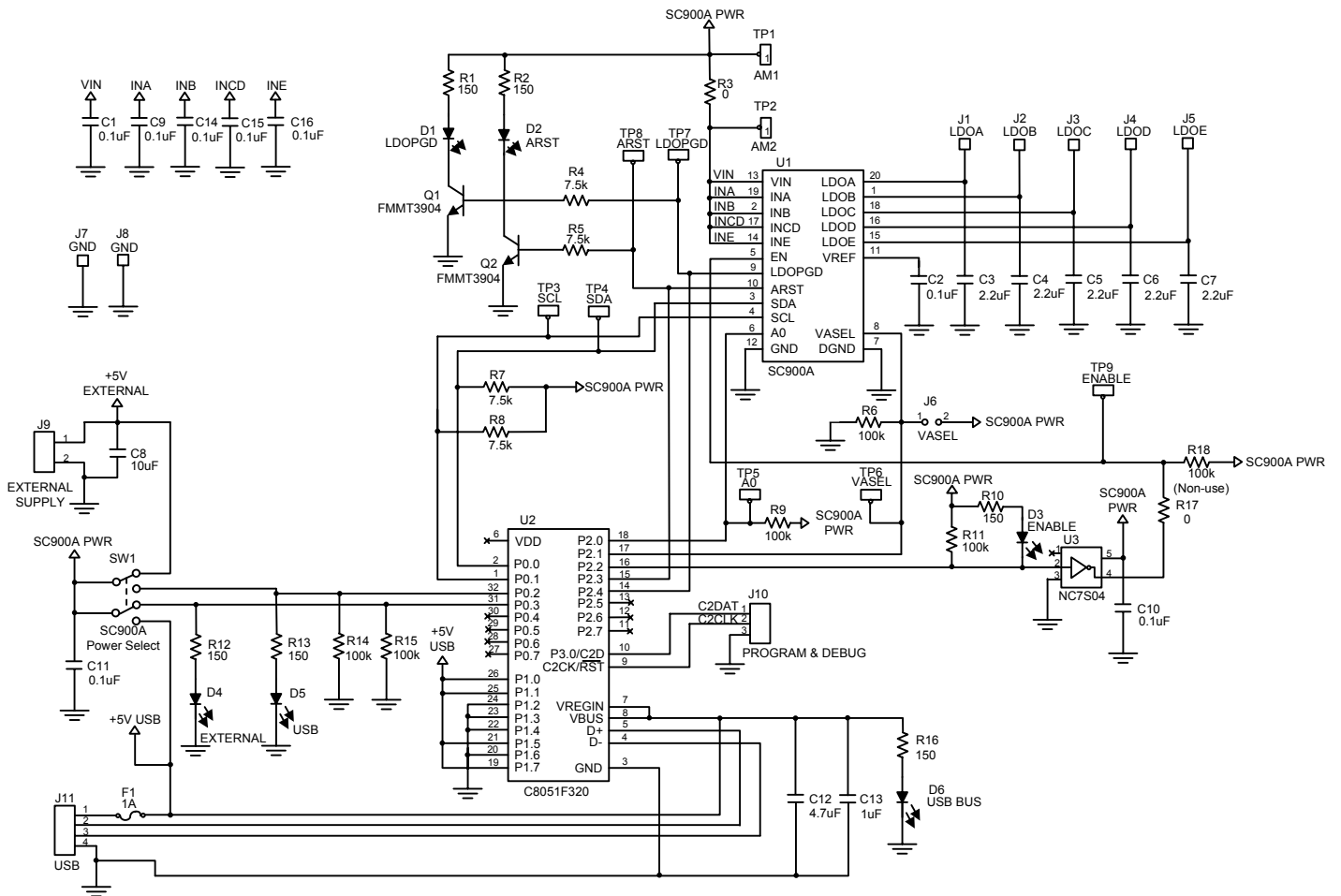



POWER MANAGEMENT

Outline Drawing - MLPQ-20L 4 x 4

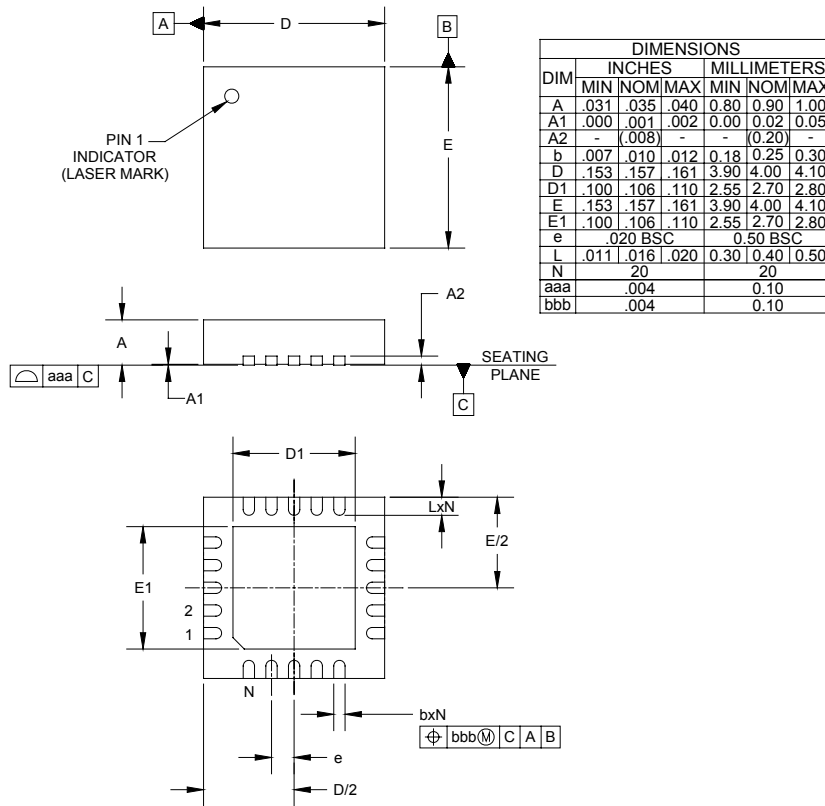

- NOTES:
1. CONTROLLING DIMENSIONS ARE IN MILLIMETERS (ANGLES IN DEGREES).
  2. COPLANARITY APPLIES TO THE EXPOSED PAD AS WELL AS THE TERMINALS.

Marking Information

Top Marking

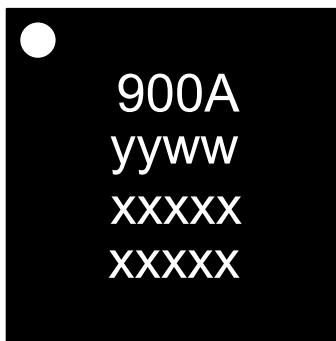

yy = two-digit year of manufacture  
 ww = two-digit week of manufacture

**POWER MANAGEMENT**

**Land Pattern - MLPQ-20L 4 x 4**

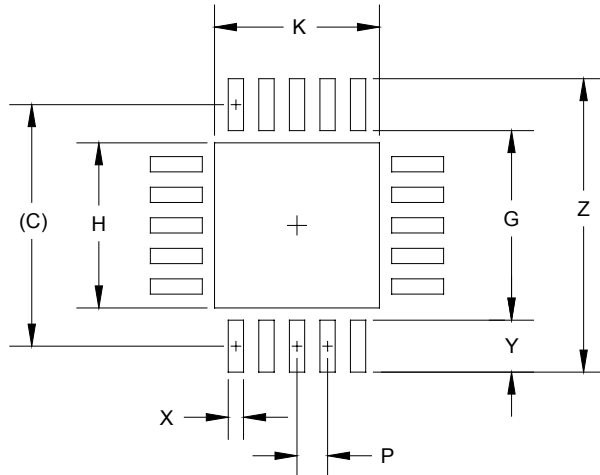

DIMENSIONS		
DIM	INCHES	MILLIMETERS
C	(.155)	(3.95)
G	.122	3.10
H	.106	2.70
K	.106	2.70
P	.021	0.50
X	.010	0.25
Y	.033	0.85
Z	.189	4.80

**NOTES:**

1. THIS LAND PATTERN IS FOR REFERENCE PURPOSES ONLY. CONSULT YOUR MANUFACTURING GROUP TO ENSURE YOUR COMPANY'S MANUFACTURING GUIDELINES ARE MET.

**Contact Information**

Semtech Corporation  
 Power Management Products Division  
 200 Flynn Road, Camarillo, CA 93012  
 Phone: (805) 498-2111 FAX (805)498-3804