

# 0.50mm

## (0.02") PITCH CONNECTOR



### Material

I/NO	DESCRIPTION	MATERIAL
1	HOUSING	PA46 or LCP, UL94V-0
2	TERMINAL	Phosphor Bronze, Tin/Au-plated
3	HOOK	Phosphor Bronze, Tin/Au-plated

**FPC/FFC  
Connectors**

### Housing

<p>Emboss Type</p>	<p>SMT Type</p>
<p>NonZIF Type</p>	<p>Dual Contact</p>

### Available Pin

PARTS NO.	A	B	C
05010HR-04C	5.1	2.50	1.50
05010HR-05C	5.6	3.00	2.00
05010HR-06C	6.1	3.50	2.50
05010HR-07C	6.6	4.00	3.00
05010HR-08C	7.1	4.50	3.50
05010HR-09C	7.6	5.00	4.00
05010HR-10C	8.1	5.50	4.50
05010HR-11C	8.6	6.00	5.00
05010HR-12C	9.1	6.50	5.50
05010HR-13C	9.6	7.00	6.00
05010HR-14C	10.1	7.50	6.50
05010HR-15C	10.6	8.00	7.00
05010HR-16C	11.1	8.50	7.50
05010HR-17C	11.6	9.00	8.00
05010HR-18C	12.1	9.50	8.50
05010HR-19C	12.6	10.0	9.00
05010HR-20C	13.1	10.5	9.50

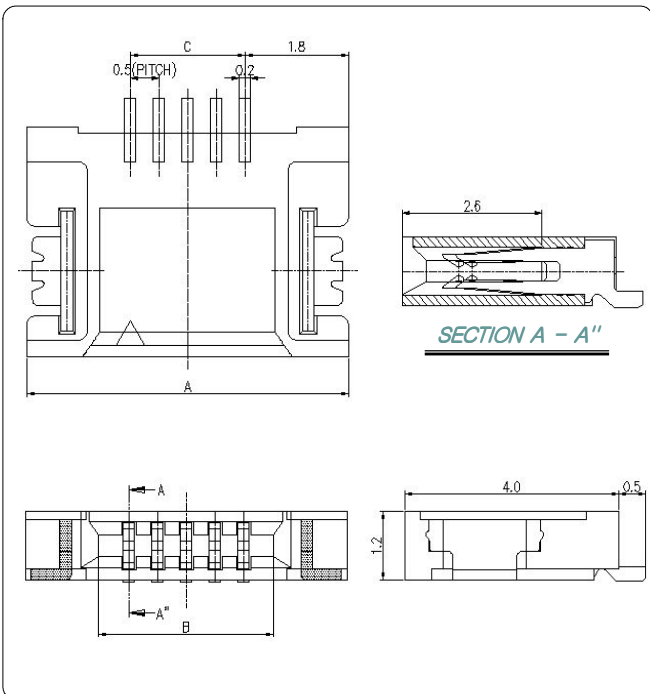

### Specification

ITEM	SPEC
Voltage Rating	AC/DC 50V
Current Rating	AC/DC 0.5A
Operating Temperature	-25°C ~ +85°C
Contact Resistance	30mΩ MAX
Withstanding Voltage	AC250V/1min
Insulation Resistance	100MΩ MIN
Applicable Wire	-
Applicable P.C.B	0.8 ~ 1.6mm
Applicable FPC/FFC	0.30±0.02mm
Solder Height	0.15mm
Crimp Tensile Strength	-
UL FILE NO	-

