



# Technical Data Sheet

## POWER LED

**37-05/G4C-AQSB**

### Features

- . High Flux Output.
- . Designed for High Current Operation.
- . Low Thermal Resistance Rth(junction to lead):120°C/W
- . Low Profile.
- . Packaged in Tubes for Use with Automatic Insertion Equipment.
- . The product itself will remain within RoHS compliant version.
- . Viewing angle 24 × 54 degree
- . ESD-withstand voltage: up to 4KV



### Descriptions

This revolutionary package design allows the light designer to reduce the number of LEDs required and provide a more uniform and unique illuminated appearance than with other LED solutions. This is possible through the efficient optical package design and high-current capabilities.

The low profile package can be easily coupled with reflectors or lenses to efficiently distribute light and provide the desired light appearance.

### Applications

- . Automotive Lighting
- . Electronic Signs and Signals
- . Special Lighting application

### Device Selection Guide

PART NO.	Chip		Lens Color
	Material	Emitted Color	
37-05/G4C-AQSB	InGaN	Brilliant Green	Water Clear

# Technical Data Sheet

## POWER LED

**37-05/G4C-AQSB**

### Package Dimensions

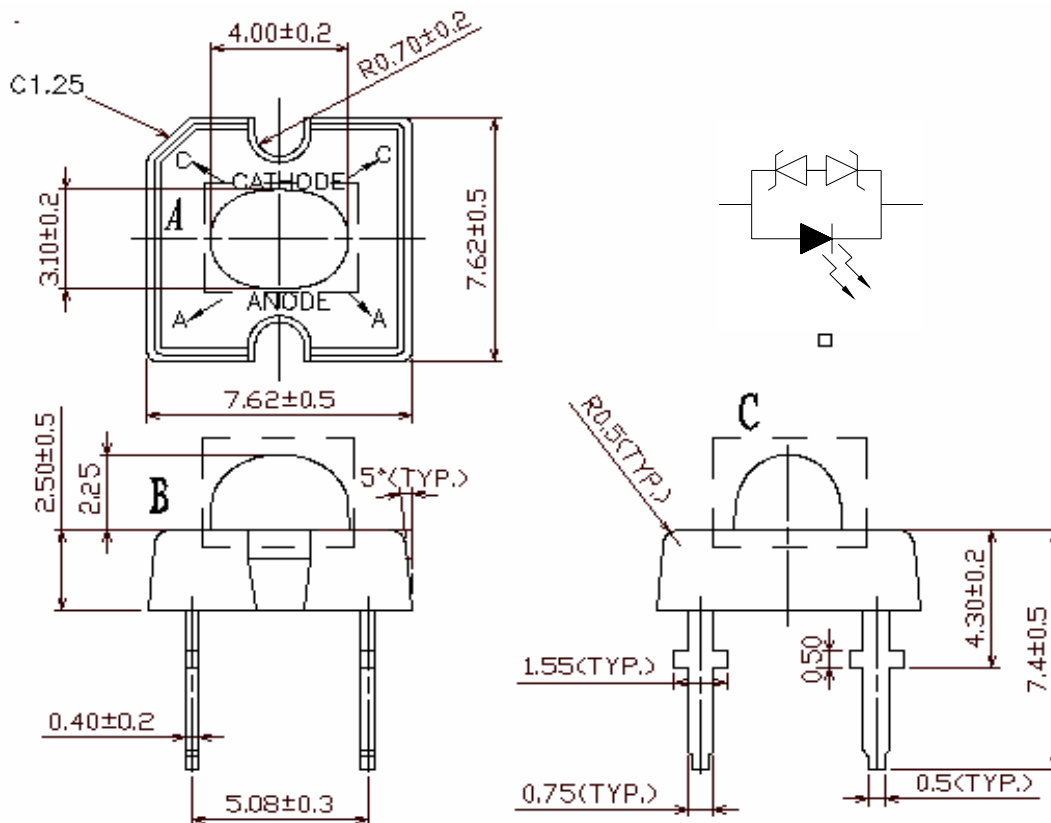

### Absolute Maximum Ratings ( $T_a=25^\circ\text{C}$ )

Parameter	Symbol	Rating	Units
Continuous Forward Current	$I_F$	30	mA
Peak Forward Current(Duty 1/10 @ 1KHZ)	$I_{FP}$	100	mA
Reverse Voltage	$V_R$	5	V
Operating Temperature	$T_{opr}$	-40 ~ +85	$^\circ\text{C}$
Storage Temperature	$T_{stg}$	-40 ~ +100	$^\circ\text{C}$
Soldering Temperature( $T=5$ sec)	$T_{sol}$	$260 \pm 5$	$^\circ\text{C}$
LED Junction Temperature	$T_j$	125	$^\circ\text{C}$
Power Dissipation	$P_d$	100	mW
Zener Reverse Current	$I_Z$	100	mA
Electrostatic Discharge	ESD	4000	V



# Technical Data Sheet

## POWER LED

**37-05/G4C-AQSB**

### Electro-Optical Characteristics (Ta=25°C)

Parameter	Symbol	Min.	Typ.	Max.	Condition	Unit
Total Flux	$\Phi_v$	3600	4500	7150	I <sub>F</sub> =30mA	mlm
Viewing Angle	2θ 1/2	----	24 × 54	----	I <sub>F</sub> =30mA	deg
Peak Wavelength	λ <sub>p</sub>	----	518	----	I <sub>F</sub> =20mA	nm
Dominant Wavelength	λ <sub>d</sub>	520	525	532	I <sub>F</sub> =20mA	nm
Spectrum Radiation Bandwidth	Δλ	----	36	----	I <sub>F</sub> =20mA	nm
Forward Voltage	V <sub>F</sub>	3.0	3.5	4.0	I <sub>F</sub> =30mA	V
Zener Reverse Voltage	V <sub>Z</sub>	----	----	10	I <sub>Z</sub> =5mA	V

### Rank

37-05/G4C-AQSB

(1)

(2)

(3)

(1) V <sub>F</sub> (V)			(2) λ <sub>d</sub> (nm)			(3) Φ <sub>v</sub> (mlm)		
Bin	Min	Max	Bin	Min	Max	Bin	Min	Max
1	3.00	3.20	3	520	524	Q	3600	4500
2	3.20	3.40	4	524	528	R	4500	5650
3	3.40	3.60	5	528	532	S	5650	7150
4	3.60	3.80						
5	3.80	4.00						

\*Measurement Uncertainty of Forward Voltage : ±0.1V

\*Measurement Uncertainty of Luminous Intensity: ±15%

\*Measurement Uncertainty of Dominant Wavelength ±1.0nm



# Technical Data Sheet

## POWER LED

**37-05/G4C-AQSB**

### Typical Electro-Optical Characteristics Curves

**Relative Intensity vs. Wavelength**

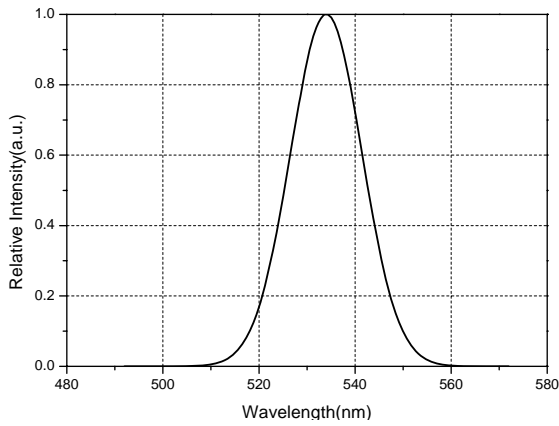

**Forward Current vs. Forward Voltage**

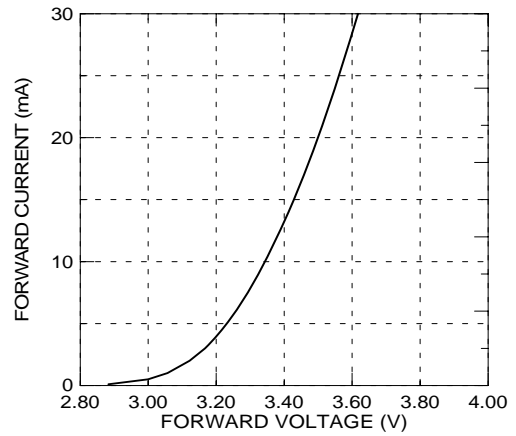

**Relative Intensity vs. Forward Current**

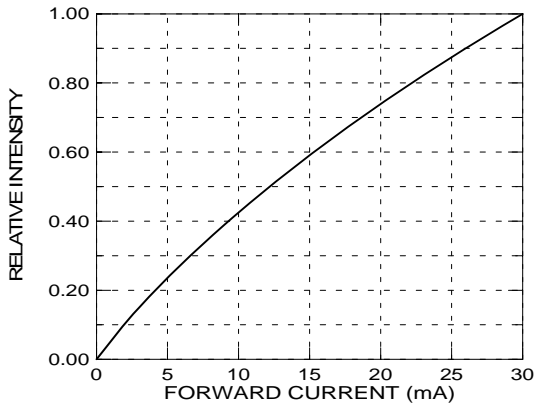

**Forward Current vs. Ambient Temp.**

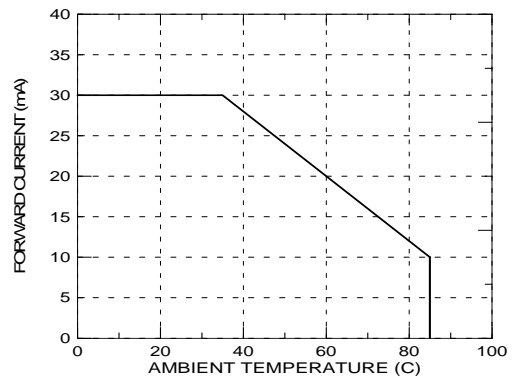

**Relative Intensity vs. Angle Displacement**

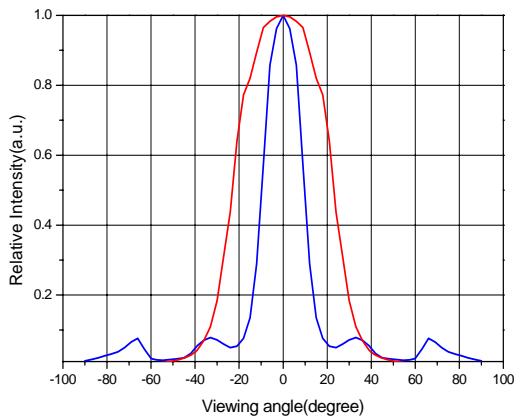

**Relative Intensity vs. Off Axis Angle**

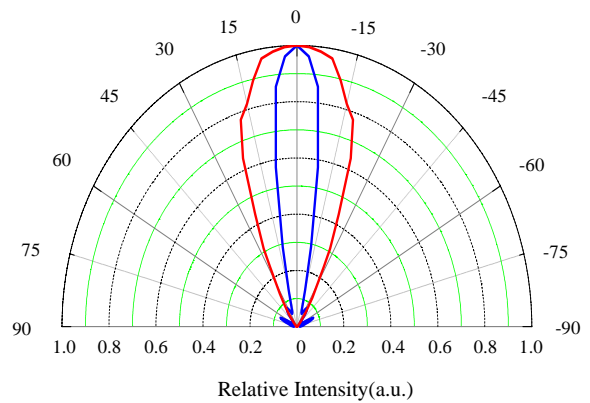





# Technical Data Sheet POWER LED

**37-05/G4C-AQSB**

## Packing Quantity Specification

- (1) 60 pcs/1 tube, 30 tubes/1 small inside box, 12 small inside boxes/1 outside box.
- (2) 60 pcs/1 tube, 105 tubes/1 big inside box, 8 big inside boxes/1 outside box.

## Label Form Specification

<b>EVERLIGHT</b>	
CPN:	
P/N:	
	<b>RoHS</b>
37-05/G4C-AQSB	
QTY :	CAT:
	HUE:
LOT NO :	REF:
	
MADE IN TAIWAN	

CPN: Customer's Production Number  
P/N : Production Number  
QTY: Packing Quantity  
CAT: Forward Voltage, Wavelength and Flux  
HUE: Space  
REF: Reference  
LOT No: Lot Number  
MADE IN TAIWAN: Production Place

# Technical Data Sheet

## POWER LED

**37-05/G4C-AQSB**

### Notes

1. Above specification may be changed without notice. EVERLIGHT will reserve authority on material change for above specification.
2. When using this product, please observe the absolute maximum ratings and the instructions for using outlined in these specification sheets. EVERLIGHT assumes no responsibility for any damage resulting from use of the product which does not comply with the absolute maximum ratings and the instructions included in these specification sheets.
3. These specification sheets include materials protected under copyright of EVERLIGHT corporation. Please don't reproduce or cause anyone to reproduce them without EVERLIGHT's consent.
4. Below the zener reference voltage  $V_z$ , all the current flows through LED and as the voltage rises to  $V_z$ , the zener diode "breakdown." If the voltage tries to rise above  $V_z$  current flows through the zener branch to keep the voltage at exactly  $V_z$ .
5. When the LED is connected using serial circuit, if either piece of LED is no light up but current can't flow through causing others to light down. In new design, the LED is parallel with zener diode. if either piece of LED is no light up but current can flow through causing others to light.

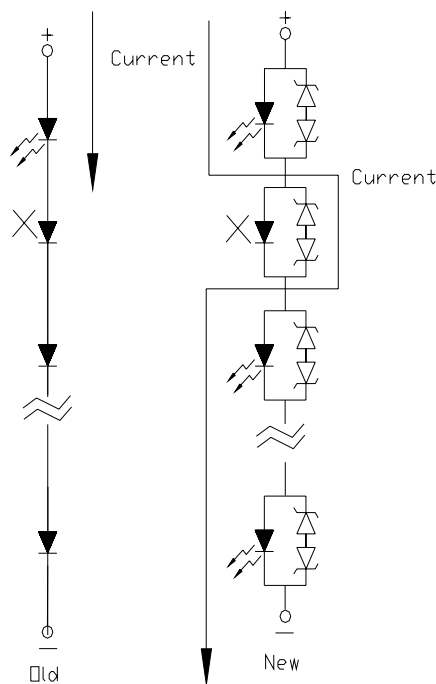

### 6. Soldering Condition



# Technical Data Sheet

## POWER LED

### 37-05/G4C-AQSB

Careful attention should be paid during soldering. When soldering, leave more than 3mm from solder joint to case, and soldering beyond the base of the tie bar is recommended.

Avoiding applying any stress to the lead frame while the LEDs are at high temperature particularly when soldering.

Recommended soldering conditions:

Hand Soldering		DIP Soldering	
Temp. at tip of iron	400°C Max. (30W Max.)	Preheat temp.	100°C Max. (60 sec Max.)
Soldering time	3 sec Max.	Bath temp.	265 Max.
Distance	3mm Min.(From solder joint to case)	Bath time.	5 sec Max.
		Distance	3mm Min.

**EVERLIGHT ELECTRONICS CO., LTD.**  
Office: No 25, Lane 76, Sec 3, Chung Yang Rd,  
Tucheng, Taipei 236, Taiwan, R.O.C

Tel: 886-2-2267-2000, 2267-9936  
Fax: 886-2267-6244, 2267-6189, 2267-6306  
<http://www.everlight.com>