

# High Reliability Surface Mount LVCMOS Clock Oscillator Series

# CONNOR WINFIELD



## Description

The Connor-Winfield's XH7xx and XH9xx, High Reliability Series are 5x7.5mm Surface Mount, Fixed Frequency Crystal Controlled Oscillators (XO). Designed for applications requiring tight frequency stability over a wide temperature range, operating at 2.5V or 3.3V supply voltage, the XH7xx and XH9xx series provides a LVCMOS Output with enable / disable function. RoHS Compliant / Lead Free. ✓RoHS



## Features:

### Model XH7xx - XH9xx Series Pure Spectrum™ Technology

5.0 x7.0mm Surface Mount Package  
Supply Voltages: 2.5V or 3.3V  
LVCMOS Output Logic  
Frequency Stabilities: +/-50ppm / +/-100ppm  
Temperature Ranges: -55 to 125°C / -55 to 85°C  
Low Jitter <1pS RMS  
Sub-harmonics / Spurious: -70 dBc  
Minimal Frequency Perturbations: 3ppm Max.  
Guaranteed Proper Frequency Startup.  
Gold Plated Terminations

## Model Specifications

### Absolute Maximum Ratings

Parameter	Units	Minimum	Nominal	Maximum	UNITS	Note
Storage Temperature		-55	-	125	°C	
Supply Voltage	(Vcc)	-0.5	-	5.0	Vdc	

### Operating Specifications

Parameter		Minimum	Nominal	Maximum	UNITS	Note
Frequency Range	(Fo)	40	-	200	MHz	
Total Frequency Tolerance						
	Models XH72x, XH92x	-50	-	50	ppm	1
	Models XH73x, XH93x	-100	-	100	ppm	1
Operating Temperature Range						
	Models XH7xx, XH7xx	-55	-	125	°C	
	Models XH9xx, XH9xx	-55	-	85	°C	
Supply Voltage (Vcc)						
	Models XH7x2, XH9x2	2.375	2.500	2.625	Vdc	
	Models XH7x3, XH9x3	3.135	3.300	3.465	Vdc	
Supply Current (Icc)						
	40 to 79.999 MHz	-	-	20	mA	
	80 to 89.999 MHz	-	-	30	mA	
	90 to 124.999 MHz	-	-	40	mA	
	125 to 164.999 MHz	-	-	50	mA	
	165 to 225 MHz	-	-	65	mA	

### Input Characteristics

Parameter		Minimum	Nominal	Maximum	Units	Note
Enable Voltage	(High) (Vih)	0.7Vcc	-	-	Vdc	2
Disable Voltage	(Low) (Vil)	-	-	0.3Vcc	Vdc	2
Enable Time		-	-	2	ms	
Disable Time		-	-	200	ns	
Output Disable Current (Standby Current)	(Icc)	-	-	10	uA	

### LVCMOS Output Characteristics

Parameter		Minimum	Nominal	Maximum	Units	Note
LOAD		-	-	15	pF	
Voltage	(High) (Voh)	Vcc-0.4	-	-	Vdc	
	(Low) (Vol)	-	-	0.4	Vdc	
Current	(High) (Ioh)	-8	-	-	mA	
	(Low) (Iol)	-	-	8	mA	
Duty Cycle at 50% of Vcc		45	50	55	%	
Rise / Fall Time 10% to 90%		-	1	2	ns	
Start-Up Time		-	-	2	ms	3
Period Jitter		-	3	5	ps RMS	
Phase Jitter (BW=12kHz to 20MHz)		-	0.5	1	ps RMS	
SSB Phase Noise at 10Hz offset		-	-60	-	dBc/Hz	
SSB Phase Noise at 100Hz offset		-	-90	-	dBc/Hz	
SSB Phase Noise at 1KHz offset		-	-125	-	dBc/Hz	
SSB Phase Noise at 10KHz offset		-	-140	-	dBc/Hz	
SSB Phase Noise at 100KHz offset		-	-145	-	dBc/Hz	
Sub-harmonics		-	-	-70	dBc	
Spurious		-	-	-70	dBc	
Frequency Perturbations over Temperature		-	-	3	ppm	4

### Package Characteristics

Package	Hermetically sealed ceramic package and metal cover.
Package Terminations	Solder pads are Au plated, thickness 0.30 to 1.00 Micron.

Specifications subject to change without notice. All dimensions in inches. © Copyright 2008 The Connor-Winfield Corporation

2111 Comprehensive Drive  
Aurora, Illinois 60505  
Phone: 630-851-4722  
Fax: 630-851-5040

[www.conwin.com](http://www.conwin.com)

US Headquarters:  
630-851-4722  
European Headquarters:  
+353-61-472221



Bulletin	<b>Sm127</b>
Page	<b>1 of 2</b>
Revision	<b>01</b>
Date	<b>15 Sep 2008</b>



**Notes**

- 1) Inclusive of calibration @ 25°C, frequency vs. temperature stability, supply voltage change, load change, shock and vibration, 10 years aging.
- 2) When the oscillator is disabled, the outputs are at high impedance. Output is enabled with no connection on pad 1.
- 3) Oscillator is guaranteed to start at the specified frequency (Fo) under all conditions.
- 4) This part will not exhibit frequency jumps of more than 3ppm when tested every 2°C within the operating temperature range, specified supply voltage and load.

**Ordering Information**

<b>XH</b>	<b>7</b>	<b>2</b>	<b>3</b>	-	<b>150.0M</b>
Type: High Reliability Clock LVCMOS Series 5x7mm	Temperature Range: 7 = -55 to 125° C 9 = -55 to 85° C	Frequency Stability: 2 = +/-50 ppm 3 = +/-100 ppm	Supply Voltage: 2 = 2.5Vdc. 3 = 3.3Vdc.		Output Frequency: Frequency Format -xxx.xM Min.* -xxx.xxxxxM Max.* *Amount of numbers after the decimal point M = MHz

Example: XH723-150.0M = High Reliability, 5x7mm, LVCMOS Clock, -55 to 125C, +/-50ppm, 3.3Vdc, Output Frequency 150MHz  
 To order an XH723 with an output frequency of:  
 40 MHz = XH723-040.0M  
 74.25 MHz = XH723-074.25M  
 155.52 MHz = XH723-155.52M

**Environmental Characteristics**

Vibration:	Vibration per Mil Std 883E Method 2007.3 Test Condition A
Shock:	Mechanical Shock per Mil Std 883E Method 2002.4 Test Condition B.
Soldering:	RoHS compliant, lead free. See solder profile.
Solderability:	Solderability per Mil Std 883E Method 2003

**Pad Connections - Enable / Disable Function**

Pad	Connection	Enable / Disable Function (Pad 1)	Output
1	Enable/Disable	High or Open	Enable
2	Ground	Low	Disable (High Impedance)
3	Output		
4	Vcc		

**Model Matrix**

Frequency Tolerance ±50ppm	Frequency Tolerance ±100ppm	Supply Voltage	Temperature Range
XH722	XH732	2.5Vdc	-55 to 125°C
XH723	XH733	3.3Vdc	-55 to 125°C
XH922	XH932	2.5Vdc	-55 to 85°C
XH923	XH933	3.3Vdc	-55 to 85°C

**Tape and Reel Specifications**

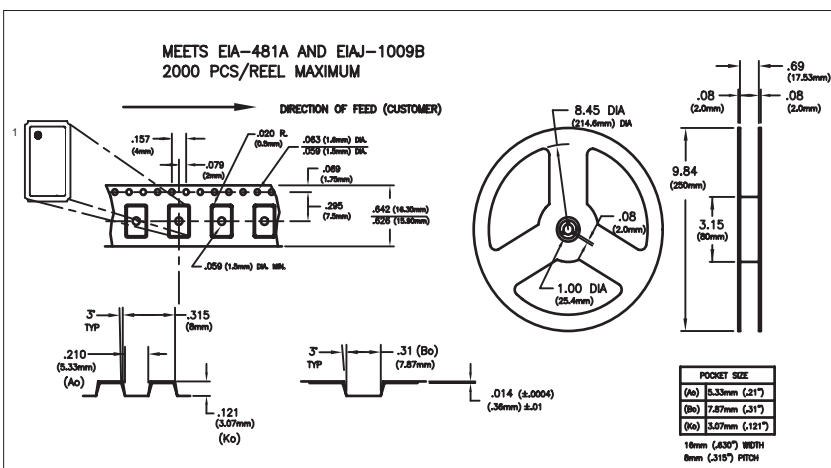

**Package Outline**

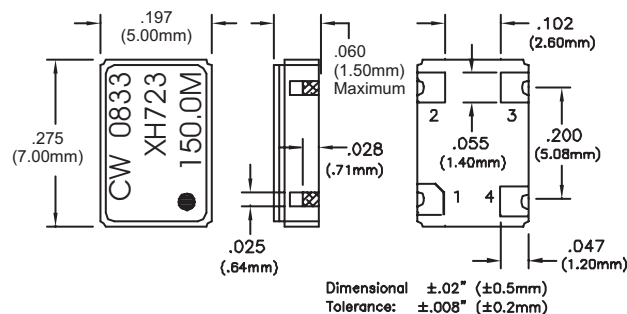

**Suggested Pad Layout**

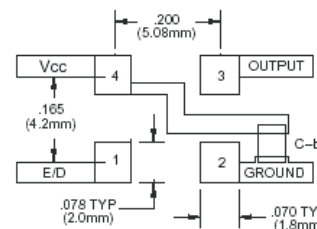

Bypass capacitor, C-by, should be ceramic capacitor ≥ .01uf.

**Solder Profile**

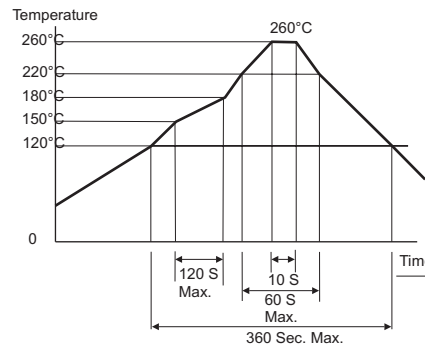

**LVCMOS Output Waveform**

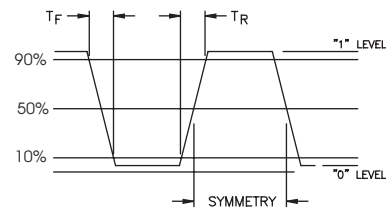

US Headquarters:  
630-851-4722  
European Headquarters:  
+353-61-472221

Bulletin	SM127
Page	2 of 2
Revision	01
Date	15 Sep 2008