

Silicon NPN Power Transistors

2SC3627

DESCRIPTION

- With TO-220Fa package
- High collector breakdown voltage

APPLICATIONS

- Switching regulator and high voltage switching applications
- High speed DC-DC converter applications

PINNING

PIN	DESCRIPTION
1	Base
2	Collector
3	Emitter

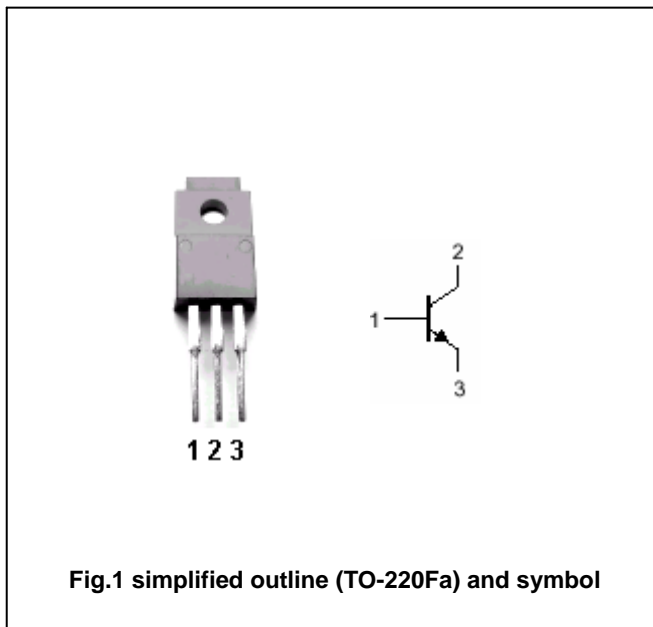

Absolute maximum ratings (Ta=25)

SYMBOL	PARAMETER	CONDITIONS	VALUE	UNIT
V _{CBO}	Collector-base voltage	Open emitter	250	V
V _{CEO}	Collector-emitter voltage	Open base	200	V
V _{EBO}	Emitter-base voltage	Open collector	7	V
I _C	Collector current		10	A
I _{CM}	Collector current-peak		15	A
I _B	Base current		2	A
P _C	Collector power dissipation	T _a =25	2.0	W
		T _C =25	30	
T _j	Junction temperature		150	
T _{stg}	Storage temperature		-55~150	

Silicon NPN Power Transistors

2SC3627

CHARACTERISTICS

T_j=25 unless otherwise specified

SYMBOL	PARAMETER	CONDITIONS	MIN	TYP.	MAX	UNIT
V _{(BR)CEO}	Collector-emitter breakdown voltage	I _C =10mA; I _B =0	200			V
V _{(BR)CBO}	Collector-base breakdown voltage	I _C =1mA; I _E =0	250			V
V _{CEsat}	Collector-emitter saturation voltage	I _C =5 A; I _B =0.5 A			1.0	V
V _{BEsat}	Base-emitter saturation voltage	I _C =5 A; I _B =0.5 A			1.5	V
I _{CBO}	Collector cut-off current	V _{CB} =200V ; I _E =0			100	μ A
I _{EBO}	Emitter cut-off current	V _{EB} =7V ; I _C =0			1	mA
h _{FE-1}	DC current gain	I _C =10mA ; V _{CE} =5V	15			
h _{FE-2}	DC current gain	I _C =5A ; V _{CE} =5V	20		80	

Switching times

t _r	Rise time				1.0	μ s
t _s	Storage time	V _{CC} =150V, R _L =25 I _{B1} =-I _{B2} =0.6 A			2.5	μ s
t _f	Fall time				1.0	μ s

