



CHENMKO ENTERPRISE CO.,LTD

SURFACE MOUNT GLASS PASSIVATED FAST RECOVERY SILICON RECTIFIER

VOLTAGE RANGE 50 - 1000 Volts CURRENT 1.0 Ampere

**FBM11PT
THRU
FBM17PT**

Lead free devices

FEATURES

- * Low leakage current
- * Ideal for surface mounted applications
- * Metallurgically bonded construction
- * Fast recovery times for high efficiency
- * Plastic package has Underwriters Laboratory Flammability Classification 94V-0
- * Glass passivated junction
- * High temperature soldering guaranteed : 260°C/10 seconds at terminals

MECHANICAL DATA

Case: JEDEC SMB molded plastic
Terminals: Solder plated, solderable per MIL-STD-750, Method 2026
Polarity: Indicated by cathode band
Weight: 0.003 ounces, 0.093 gram

MAXIMUM RATINGS AND ELECTRICAL CHARACTERISTICS

Ratings at 25°C ambient temperature unless otherwise specified.
 Single phase, half wave, 60 Hz, resistive or inductive load.
 For capacitive load, derate current by 20%.

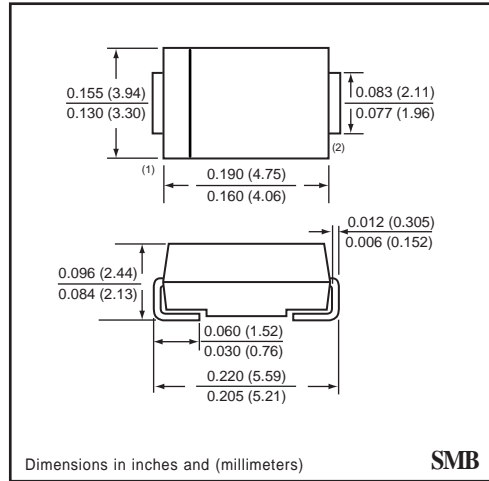

MAXIMUM RATINGS (At TA = 25°C unless otherwise noted)

RATINGS		SYMBOL	FBM11PT	FBM12PT	FBM13PT	FBM14PT	FBM15PT	FBM16PT	FBM17PT	UNITS	
Maximum Recurrent Peak Reverse Voltage		V _{RRM}	50	100	200	400	600	800	1000	Volts	
Maximum RMS Voltage		V _{RMS}	35	70	140	280	420	560	700	Volts	
Maximum DC Blocking Voltage		V _{DC}	50	100	200	400	600	800	1000	Volts	
Maximum Average Forward Rectified Current T _L = 110°C		I _O	1.0								Amps
Peak Forward Surge Current 8.3 ms single half sine-wave superimposed on rated load (JEDEC method)		I _{FSM}					30				Amps
Typical Junction Capacitance (Note 1)		C _J					15				pF
Maximum Thermal Resistance	(Note 2)	R _{θJL}					30				°C / W
	(Note 3)	R _{θJA}					75				°C / W
Operating and Storage Temperature Range		T _J , T _{STG}	-65 to +150								°C

ELECTRICAL CHARACTERISTICS (At TA = 25°C unless otherwise noted)

CHARACTERISTICS		SYMBOL	FBM11PT	FBM12PT	FBM13PT	FBM14PT	FBM15PT	FBM16PT	FBM17PT	UNITS	
Maximum Instantaneous Forward Voltage at 1.0 A DC		V _F	1.3								Volts
Maximum DC Reverse Current at Rated DC Blocking Voltage at TA = 25°C		I _R	5.0								uAmps
Maximum Full Load Reverse Current Average, Full Cycle at TA = 55°C			100								uAmps
Maximum Reverse Recovery Time (Note 4)		t _{rr}	150			250		500		nSec	

- NOTES : 1. Measured at 1.0 MHz and applied reverse voltage of 4.0 volts
 2. Thermal Resistance Junction to terminal 6.0 mm² copper pads to each terminal
 3. Thermal Resistance Junction to ambient 6.0 mm² copper pads to each terminal
 4. Test Conditions : I_F = 0.5 A, I_R = -1.0 A, I_{RR} = -0.25 A

2004-10

RATING CHARACTERISTIC CURVES (FBM11PT THRU FBM17PT)

FIG. 1 - TEST CIRCUIT DIAGRAM AND REVERSE RECOVERY TIME CHARACTERISTIC

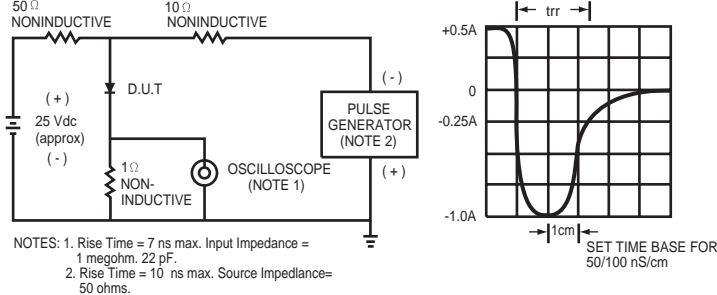

FIG. 2 - TYPICAL FORWARD CURRENT DERATING CURVE

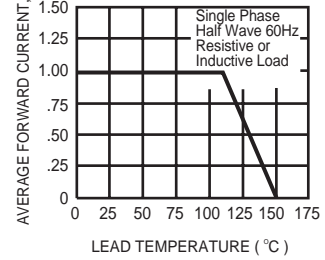

FIG. 3 - TYPICAL REVERSE CHARACTERISTICS

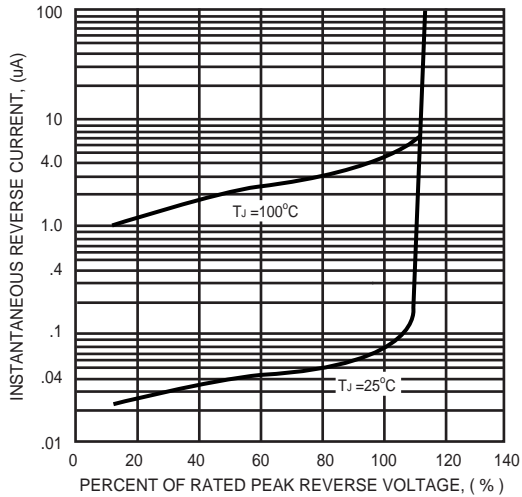

FIG. 4 - TYPICAL INSTANTANEOUS FORWARD CHARACTERISTICS

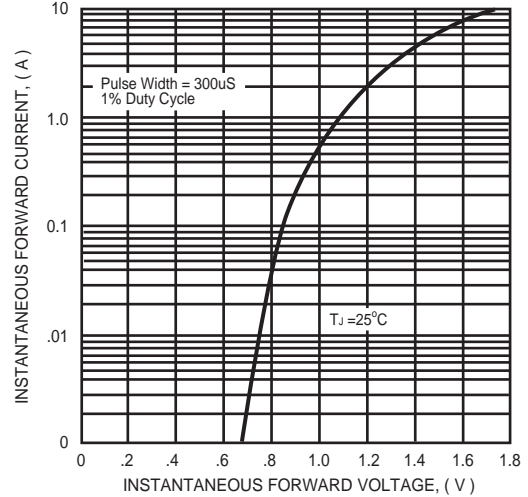

FIG. 5 - MAXIMUM NON-REPETITIVE FORWARD SURGE CURRENT

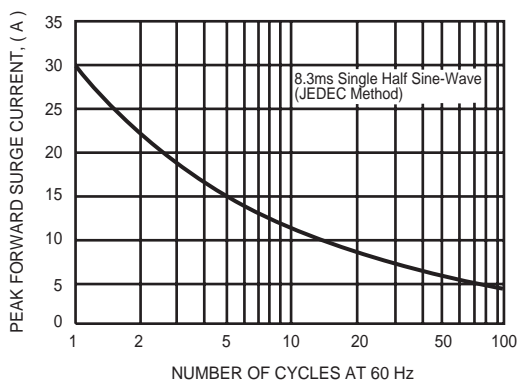

FIG. 6 - TYPICAL JUNCTION CAPACITANCE

