

Finisar

Preliminary Product Specification

DWDM GBIC Transceiver

FTR-1629-XX

PRODUCT FEATURES

- Up to 1.25 Gb/s bi-directional data links
- Standard GBIC footprint
- Temperature-stabilized DWDM-rated DFB laser transmitter
- 100GHz ITU Grid, C Band
- Very low jitter
- Metal enclosure for low EMI
- Extended operating range: 0°C to 70°C case temperature
- Wavelength controlled within ± 0.1 nm over entire temperature range
- Extended link budget of **30dB** with APD receiver technology



APPLICATIONS

- ITU grid optical networks
- Bandwidth aggregation
- Ring topologies with OADM

Finisar's Dense Wavelength-Division Multiplexing (DWDM) transceivers offer DWDM transport with dramatically lower power and cost in a standard pluggable GBIC package. The FTR-1629 is designed expressly for service providers deploying DWDM networking equipment in metropolitan access and core networks. The fiber link budget has been enhanced to 30dB with an Avalanche Photo Diode (APD) receiver.

The FTR-1629 has serial identification features as described for Module Definition "4" GBICs in the GBIC Specification Revision 5.5¹. In addition, digital diagnostic features are implemented as described in Finisar Application Note AN-2030, "Using the Finisar GBIC I²C Test/Diagnostics Port"².

Finisar

PRODUCT SELECTION

Product Code	Frequency (THz)	Center Wavelength (nm)
FTR-1629-17	191.7	1563.86
FTR-1629-18	191.8	1563.05
FTR-1629-19	191.9	1562.23
FTR-1629-20	192.0	1561.42
FTR-1629-21	192.1	1560.61
FTR-1629-22	192.2	1559.79
FTR-1629-23	192.3	1558.98
FTR-1629-24	192.4	1558.17
FTR-1629-25	192.5	1557.36
FTR-1629-26	192.6	1556.55
FTR-1629-27	192.7	1555.75
FTR-1629-28	192.8	1554.94
FTR-1629-29	192.9	1554.13
FTR-1629-30	193.0	1553.33
FTR-1629-31	193.1	1552.52
FTR-1629-32	193.2	1551.72
FTR-1629-33	193.3	1550.92
FTR-1629-34	193.4	1550.12
FTR-1629-35	193.5	1549.32
FTR-1629-36	193.6	1548.51
FTR-1629-37	193.7	1547.72
FTR-1629-38	193.8	1546.92
FTR-1629-39	193.9	1546.12
FTR-1629-40	194.0	1545.32
FTR-1629-41	194.1	1544.53
FTR-1629-42	194.2	1543.73
FTR-1629-43	194.3	1542.94
FTR-1629-44	194.4	1542.14
FTR-1629-45	194.5	1541.35
FTR-1629-46	194.6	1540.56
FTR-1629-47	194.7	1539.77
FTR-1629-48	194.8	1538.98
FTR-1629-49	194.9	1538.19
FTR-1629-50	195.0	1537.40
FTR-1629-51	195.1	1536.61
FTR-1629-52	195.2	1535.82
FTR-1629-53	195.3	1535.04
FTR-1629-54	195.4	1534.25
FTR-1629-55	195.5	1533.47
FTR-1629-56	195.6	1532.68
FTR-1629-57	195.7	1531.90
FTR-1629-58	195.8	1531.12
FTR-1629-59	195.9	1530.33
FTR-1629-60	196.0	1529.55
FTR-1629-61	196.1	1528.77

I. Pin Out

Pin Name	Pin #	Sequence
RX_LOS	1	2
GND	2	2
GND	3	2
MOD_DEF(0)	4	2
MOD_DEF(1)	5	2
MOD_DEF(2)	6	2
TX_DISABLE	7	2
GND	8	2
GND	9	2
TX_FAULT	10	2
GND	11	1
-RX_DAT	12	1
+RX_DAT	13	1
GND	14	1
V _{CC}	15	2
V _{CC}	16	2
GND	17	1
+TX_DAT	18	1
-TX_DAT	19	1
GND	20	1

Table 1. GBIC to Host Connector Pin Assignment

“Sequence” indicates the order in which pins make contact when the device is hot plugged. See “Table 3: Signal Definitions” in the GBIC Specification Revision 5.5¹ for a description of the function of each pin listed above.

II. Electrical Power Interface

The GBIC specification calls for a range of 4.75V to 5.25 volts as described in Table 2. The maximum voltage of 6V is not to be applied continuously.

Parameter	Symbol	Min	Typ	Max	Units	Notes/Conditions
Supply Current	I_s		250	400	mA	$T_c \leq 70^\circ\text{C}$
				350	mA	$T_c \leq 65^\circ\text{C}$
Inrush Current	I_{surge}			30	mA	≤ 300 msec above steady state current
Maximum Voltage	V_{max}			6	V	
Input Voltage	V_{cc}	4.75	5.0	5.25	V	Referenced to GND

Table 2. Electrical Power Interface

III. Low Speed Signals

RX_LOS, TX_DISABLE, and TX_FAULT are TTL signals as described in Table 3. MOD_DEF(1) (SCL) and MOD_DEF(2) (SDA) are open drain CMOS signals (see section XI, “Serial Communication Protocol”). Both MOD_DEF(1) and MOD_DEF(2) must be pulled up to host_Vcc. For more detailed information, see sections 5.3.1 – 5.3.8 in the GBIC Specification Revision 5.5¹.

Parameter	Symbol	Min	Max	Units	Notes/Conditions
GBIC Output LOW	V_{OL}	0	0.5	V	4.7k to 10k pull-up to host_Vcc, measured at host side of connector
GBIC Output HIGH	V_{OH}	host_Vcc - 0.5	host_Vcc + 0.3	V	4.7k to 10k pull-up to host_Vcc, measured at host side of connector
GBIC Input LOW	V_{IL}	0	0.8	V	4.7k to 10k pull-up to Vcc, measured at GBIC side of connector
GBIC Input HIGH	V_{IH}	2	Vcc + 0.3	V	4.7k to 10k pull-up to Vcc, measured at GBIC side of connector

Table 3. Low Speed Signals – Electronic Characteristics

Parameter	Symbol	Min	Typ	Max	Units	Notes/Conditions
RX_LOS Assert Level		-42	-39		dBm	
RX_LOS Deassert Level			-37	-32	dBm	
RX_LOS Hysteresis			1		dB	
RX_LOS Assert Delay	t_loss_on			300	μsec	From detection of loss of signal to assertion of RX_LOS
RX_LOS Negate Delay	t_loss_off			150	μsec	From detection of presence of signal to negation of RX_LOS
TX_DISABLE Assert Time	t_off			100	μsec	Rising edge of TX_DISABLE to fall of output signal below 10% of nominal
TX_DISABLE Negate Time	t_on			1000	μsec	Falling edge of TX_DISABLE to rise of output signal above 90% of nominal. Time indicated is under steady-state temperature conditions.
TX_DISABLE Reset Time	t_reset	10			μsec	TX_DISABLE HIGH before TX_DISABLE set LOW
TX_FAULT Assert		-0.1		0.1	nm	TX_Fault will assert before the device is outside of specified wavelength range

Table 4. Low Speed Signal Parameters

IV. High Speed Electrical Interface

All high-speed PECL signals are AC coupled internally.

Parameter	Symbol	Min	Typ	Max	Units	Notes/Conditions
Data Input Voltage	V _{in}	650		2000	mV	PECL differential peak - peak
Data Output Voltage	V _{out}	370		2000	mV	PECL differential peak - peak
PECL rise/fall	T _r ,T _f			150	psec	20% -80% Differential
Bit Error Rate	BER			10 ⁻¹²		PRBS 2 ⁷ - 1 test data pattern
Tx Input Impedance	Z _{in}		75		Ohm	
Rx Output Impedance	Z _{out}		75		Ohm	

Table 5. High Speed Electrical Interface

V. Optical Parameters

Parameter	Symbol	Min	Typ	Max	Units	Notes/Conditions
TRANSMITTER CHARACTERISTICS						
Center Wavelength Spacing			100		GHz	Corresponds to approximately 0.8 nm
Spectral Width	$\Delta\lambda_{20}$		0.2	0.3	nm	Full width, -20dB from max
Transmitter Center Wavelength – End of Life	λ_c	X - 100	X	X + 100	pm	X = specified center wavelength
Transmitter Center Wavelength – Start of Life	λ_c	X - 80	X-50	X-20	pm	X = specified center wavelength
Side Mode Suppression Ratio (SMSR)	SMSR	30			dB	Modulated
Optical Rise/Fall Time	t_r / t_f			200	ps	Unfiltered, 80% -20%
Transmitter Optical Output Power	P_{out}	0		+3	dBm	Average power coupled into single mode fiber
Transmitter Extinction Ratio	OMI	9			dB	
Transmitter Eye Opening		40			%	IEEE 802.3 and Fibre Channel Eye Mask Margin
Total Transmitter Jitter				100	ps	Peak to peak, filtered
RECEIVER CHARACTERISTICS						
Receiver Jitter Generation				100	ps	Peak to peak, -25 dBm RX power
Optical Input Wavelength – DWDM C-Band	P_{in}	1450		1620	nm	
Optical Input Power (BER < 10 ⁻⁹)	P_{in}	-30		-7	dBm	1.25Gb/s w/ PRBS 2 ⁷ -1
Optical Input Power (BER < 10 ⁻¹²)	P_{in}	-28		-7	dBm	1.25Gb/s w/ PRBS 2 ⁷ -1
Optical Input Power – Receiver Damage Threshold				6	dBm	
Receiver Reflectance	R_{RX}			-14	dB	
Power Penalty				3.0	dB	See note 3

Note 1: Parameters are specified over temperature and voltage, at end of life unless otherwise noted.

Note 2: All parameters are measured on a Finisar GBIC Evaluation Card unless otherwise noted.

Note 3: Measured in loop back at BER= 10⁻¹² with 3600 ps/nm dispersion, 20dB ONSR, 1.25Gb/s data rate, and PRBS 2⁷-1 pattern.

Table 6. Optical Parameters

VI. Wavelength Stabilization

The laser transmitter will not be turned on until its temperature is adjusted to ensure operation within the specified channel ($X \pm 0.4\text{nm}$). This temperature stabilization time is dependent on the ambient temperature conditions, but will typically occur within 30 seconds of powering the GBIC. The device will transmit within the specified wavelength tolerance ($X \pm 0.1\text{nm}$) within 5 seconds of transmitter operation.

VII. General Specifications

Parameter	Symbol	Min	Typ	Max	Units	Notes/Conditions
Data Rate	BR	1.06		1.25	Gb/sec	Fibre Channel, IEEE 802.3 compatible
Total System Budget		28	30		dB	@ 1.25 Gb/s, BER $<10^{-12}$ w/ PRBS 2^7-1 . See Note 1

Note 1: Total system budget is defined as $P_{\text{out}} - P_{\text{in}}$ – typical connector losses.

Table 7. General Specifications

VIII. Environmental Specifications

Note that the GBIC Specification requires an ambient temperature range of 0 to +60C. Finisar FTR-1629-XX GBICs have an extended range from 0°C to +70°C case temperature as specified in Table 8.

Parameter	Symbol	Min	Typ	Max	Units	Notes/Conditions
Operating Temp	T_{op}	0		70	°C	Case temperature measured on top-side of device
Storage Temp	T_{sto}	-10		85	°C	Ambient temperature
Eye Safety						CDRH and IEC-825 Class 1 Laser Product. See Note 1

Note 1: Complies with FDA performance standards for laser products except for deviations pursuant to Laser Notice No. 50, dated July 26, 2001.

Table 8. Environmental Specifications

IX. Serial Communication Protocol

All Finisar optical GBICs implement serial identification features described for ‘Module Definition “4”’ as outlined in Annex D of the GBIC Specification ¹. These GBICs use an Atmel AT24C01A 128 byte E²PROM at address A0H. For details on interfacing with the E²PROM, see the Atmel data sheet titled “AT24C01A/02/04/08/16 2-Wire Serial CMOS E²PROM.”³

Finisar’s DWDM GBICs also support extended diagnostic features as described in Finisar Application Note AN-2030, “Using the Finisar GBIC I²C Test/Diagnostics Port”². A controller IC that monitors system parameters such as laser current, module temperature, transmitter power, and received power is accessible at address A2H.

Parameter	Symbol	Min	Typ	Max	Units	Notes/Conditions
I ² C Clock for Atmel (A0H) and Controller IC (A2H)	C _{atmel}	0		100,000	Hz	Bus can be driven blind

Table 9. I²C Timing Requirements

X. Mechanical Specifications

Finisar’s DWDM GBICs conform to the mechanical specifications outlined in the GBIC Specification Revision 5.5, Section 6¹.

Parameter	Symbol	Min	Typ	Max	Units	Notes/Conditions
GBIC insertion	F _I	0		20	Newtons	~4.5 lbs
GBIC extraction	F _E	0		15	Newtons	~3.3 lbs
GBIC retention	F _R	130			Newtons	Straight out ~29.3 lbs

Table 10. Insertion, Extraction, and Retention Forces

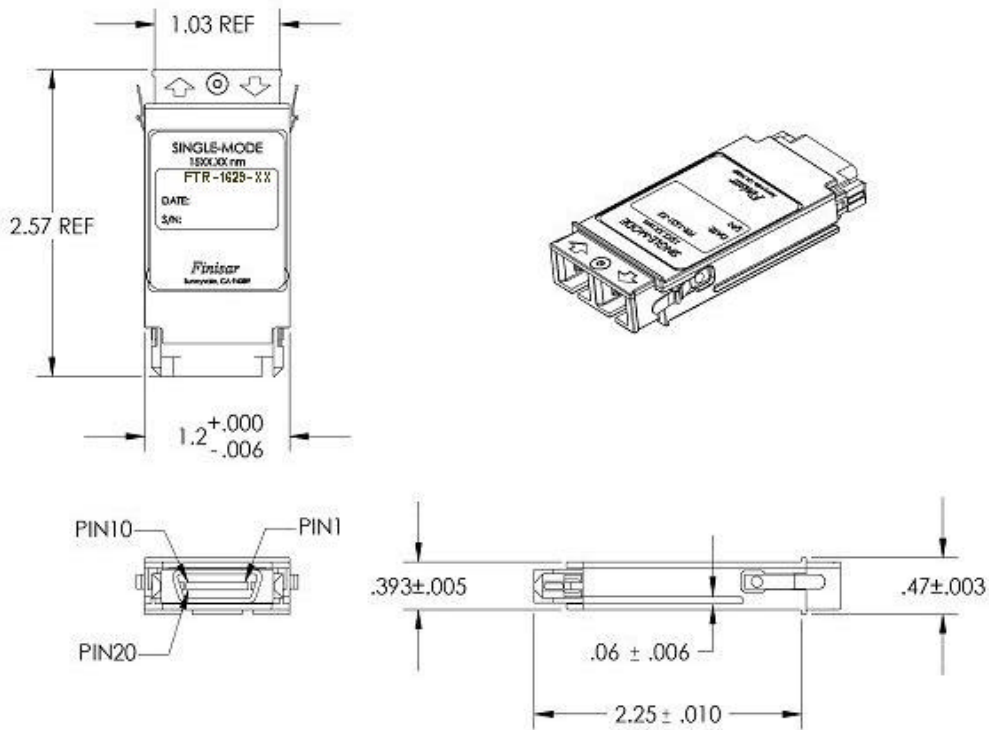

Figure 1. DWDM GBIC Outline Drawing

XI. Ordering Information

Part Number	Description
FTR-1629-XX	DWDM GBIC with APD Receiver XX = channel number (see product selection on page 2)

XI. References

1. “Gigabit Interface Converter (GBIC) Revision 5.5”.(*) Sun Microsystems Computer Company et. al., August 16, 1999. <http://playground.sun.com/pub/OEmod/>
2. “Application Note AN-2030: Digital Diagnostic Monitoring Interface for SFP Optical Transceivers”, Finisar Corporation, April 2002.
3. “AT24C01A/02/04/08/16 2-Wire Serial CMOS E²PROM”. Atmel Corporation.
www.Atmel.com

For More Information:

Finisar Corporation
1308 Moffett Park Drive
Sunnyvale, CA 94089-1133
Tel. (408) 548-1000
Fax (408) 541-6138
sales@finisar.com
www.finisar.com